



MBR3040PT SERIES

SCHOTTKY BARRIER RECTIFIERS

VOLTAGE 40 to 200 Volts **CURRENT** 30 Amperes

TO-247AD / TO-3P

Unit : inch(mm)

FEATURES

- Plastic package has Underwriters Laboratory Flammability Classification 94V-O. Flame Retardant Epoxy Molding Compound.
- Metal silicon junction, majority carrier conduction
- Low power loss, high efficiency.
- High current capability
- Guardring for overvoltage protection
- For use in low voltage,high frequency inverters free wheeling , and polarity protection applications.
- In compliance with EU RoHS 2002/95/EC directives

MECHANICAL DATA

- Case: TO-247AD/TO-3P molded plastic
- Terminals: solder plated, solderable per MIL-STD-750, Method 2026
- Polarity: As marked.
- Mounting Position: Any
- Weight: 0.2245 ounces, 6.3673 grams.

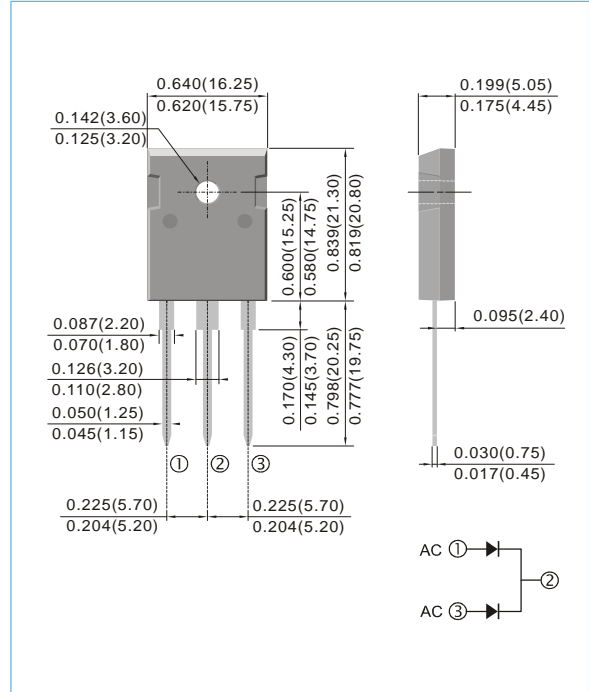

MAXIMUM RATINGS AND ELECTRICAL CHARACTERISTICS

Ratings at 25°C ambient temperature unless otherwise specified. Single phase, half wave, 60 Hz, resistive or inductive load.
For capacitive load, derate current by 20%

PARAMETER	SYMBOL	MBR3040PT	MBR3045PT	MBR3050PT	MBR3060PT	MBR3080PT	MBR3090PT	MBR30100PT	MBR30150PT	MBR30200PT	UNITS
Maximum Recurrent Peak Reverse Voltage	V_{RRM}	40	45	50	60	80	90	100	150	200	V
Maximum RMS Voltage	V_{RMS}	28	31.5	35	42	56	63	70	105	140	V
Maximum DC Blocking Voltage	V_{DC}	40	45	50	60	80	90	100	150	200	V
Maximum Average Forward Current	$I_{F(AV)}$	30									A
Peak Forward Surge Current : 8.3ms single half sine-wave superimposed on rated load (JEDEC method)	I_{FSM}	275									A
Maximum Forward Voltage at 15A per leg	V_F	0.7		0.75		0.8		0.9			V
Maximum DC Reverse Current at $T_J=25^\circ\text{C}$ Rated DC Blocking Voltage $T_J=125^\circ\text{C}$	I_R	0.1				0.05					mA
		20				20					
Typical Thermal Resistance	$R_{\theta JC}$	1.4									°C / W
Operating Junction and Storage Temperature Range	T_J, T_{STG}	-50 to +150				-65 to +175					°C

Note :

Both Bonding and Chip structure are available.



MBR3040PT SERIES

RATING AND CHARACTERISTIC CURVES

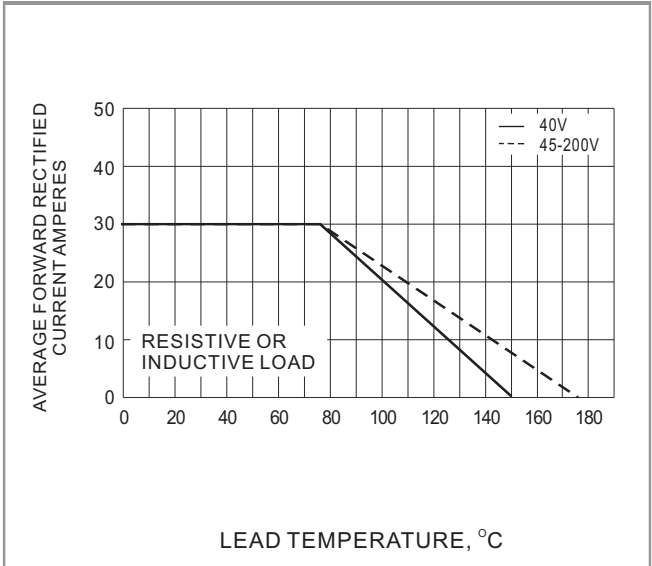

Fig.1- FORWARD CURRENT DERATING CURVE

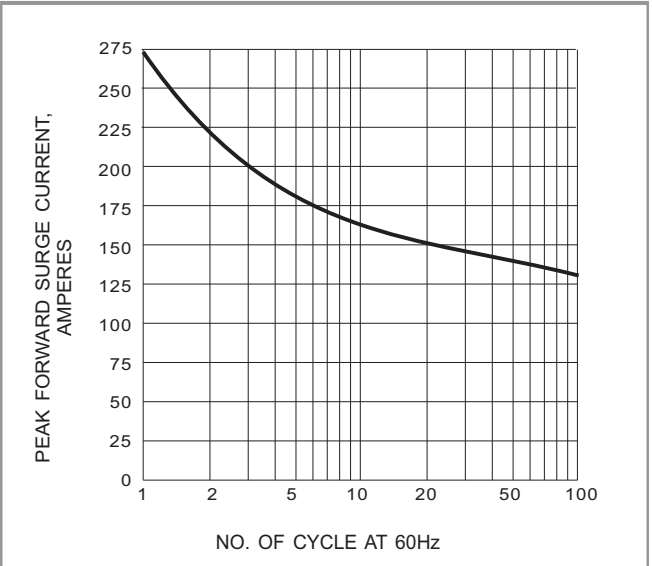

Fig.2- MAXIMUM NON-REPETITIVE SURGE CURRENT

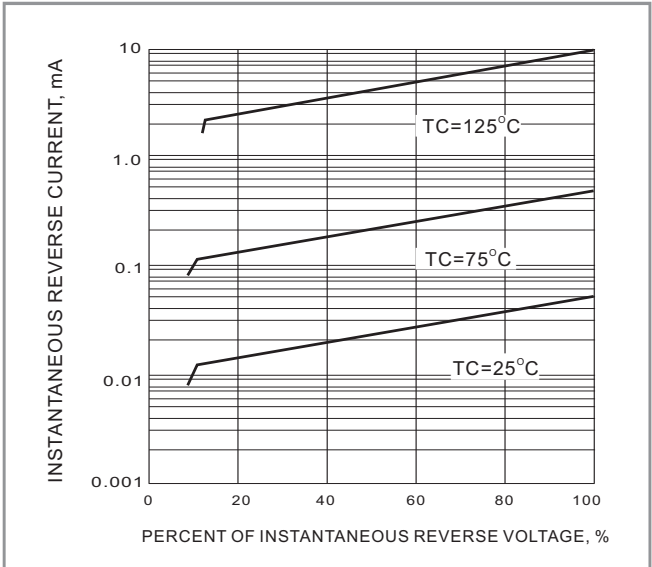

Fig.3- TYPICAL REVERSE CHARACTERISTIC

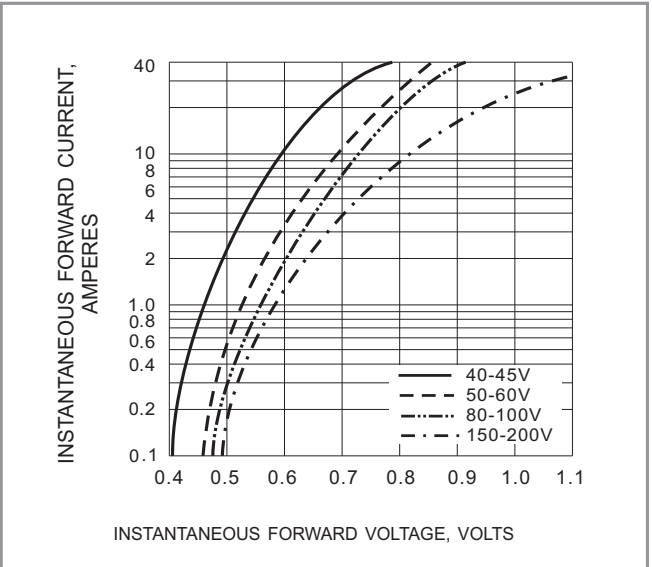

Fig.4- TYPICAL INSTANTANEOUS FORWARD CHARACTERISTIC