

ISM BAND FSK RECEIVER MODULE

RFM01

(the purpose of this spec covers mainly for the physical characteristic of the module, for register configure and its related command info please refer to [RF01 data sheets](#))

General Introduction

RFM01 is a low costing ISM band receiver module implemented with unique PLL and zero IF design approach. It works with FSK modulated signal ranges from 315/433/868/915MHZ bands, comply with FCC, ETSI regulation. The SPI interface is used to communicate with microcontroller for parameter setting. RFM01 works with RFM02 transmitter module. At 433MHZ band, the pair of module can work up to 300m in the free open air.

Features:

- Low costing, high performance and price ratio
- Tuning free during production
- FSK reception
- PLL and zero IF technology
- Fast PLL lock time
- High resolution PLL with 2.5 KHz step
- High data rate (up to 115.2 kbps with internal demodulator, with external RC filter highest data rate is 256 kbps)
- Differential antenna input
- Automatic antenna tuning
- Programmable receiver bandwidth (from 67 to 400 kHz)
- Analog and digital signal strength indicator (ARSSI/DRSSI)
- AFC
- DQD
- Internal demodulator
- SPI interface
- Clock and reset signal output for external MCU use
- 16 bits FIFO
- Low power mode (<0.5mA averaged current consumption)
- 10MHz crystal for PLL timing
- Wakeup timer
- Low battery detection
- Programmable capacitor bank
- 2.2V - 5.4V power supply
- Low power consumption
- Stand by current less than 0.3uA

Tel: +86-755-82973805 Fax: +86-755-82973550 E-mail: sales@hoperf.com <http://www.hoperf.com>

RFM01

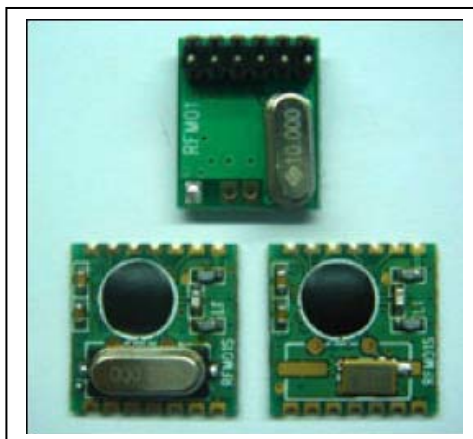

Typical Application:

- Remote control
- Remote sensor
- Wireless data collection
- Home security system
- Toys
- Tire pressure monitoring system

Pin Definition:

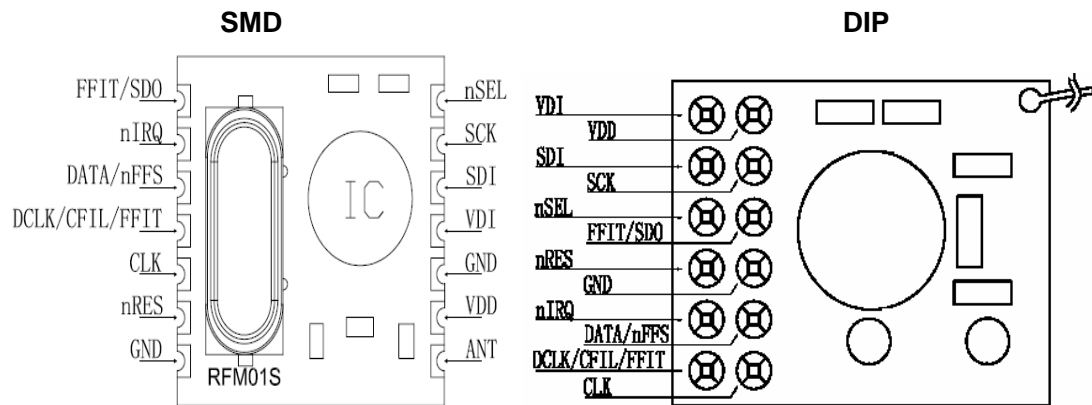

definition	Type	Function
VDI	DO	Valid data indicator
VDD	S	Positive power supply
SDI	DI	SPI data input
SCK	DI	SPI clock input
nSEL	DI	Chip select (active low)
FFIT/SDO	DO	FIFO fill interrupt(active low) or status read data output
nRES	DO	Reset output (active low)
GND	S	Power ground
nIRQ	DO	Interrupts request output (active low)
DATA/nFFS	DO/DI	Data input(non FIFO mode)/ FIFO select
DCLK/CFIL/FFIT	DO/AIO/DO	Clock output (no FIFO)/ external filter capacitor(analog mode)/ FIFO interrupts(active high)when FIFO level set to 1, FIFO empty interruption can be achieved
CLK	DO	Clock output for external microcontroller

Electrical Parameter:**Maximum (not at working mode)**

symbol	parameter	minimum	maximum	Unit
V _{dd}	Positive power supply	-0.5	6.0	V
V _{in}	All pin input level	-0.5	V _{dd} +0.5	V
I _{in}	Input current except power	-25	25	MA
ESD	Human body model		1000	V
T _{st}	Storage temperature	-55	125	°C
T _{ld}	Soldering temperature(10s)		260	°C

Recommended working range

symbol	parameter	minimum	maximum	Unit
V _{dd}	Positive power supply	2.2	5.4	V
T _{op}	Working temperature	-40	85	°C

DC characteristic

symbol	parameter	Remark	minimum	typical	maximum	Unit
I _{dd}	Current consumption	315,433MHz band 868,915MHz band		9 10.5	11 12.5	mA
I _x	Stand by current	Crystal and base band on		3. 0	3. 5	mA
I _{pd}	Sleep mode current	All blocks off		0.3		uA
I _{lb}	Low battery detection			0.5		uA
V _{lb}	Low battery step	0.1V per step	2.2		5.3	V
V _{lba}	Low battery detection accuracy			75		mV
V _{il}	Low level input				0.3*V _{dd}	V
V _{ih}	High level input		0.7*V _{dd}			V
I _{il}	Leakage current	V _{il} =0V	-1		1	uA
I _{ih}	Leakage current	V _{ih} =V _{dd} ,V _{dd} =5.4V	-1		1	uA
V _{ol}	Low level output	I _{ol} =2mA			0.4	V
V _{oh}	High level output	I _{oh} =-2mA	V _{dd} -0.4			V

AC characteristic

symbol	parameter	remark	min	typical	max	Unit
f _{ref}	PLL frequency	Parallel fundamental	8	10	12	MHz
f _{LO}	frequency (10MHz crystal used)	315 MHz band,2.5KHz step 433 MHz band,2.5KHz step 868 MHz band,5KHz step 915 MHz band,7.5KHz step	310.24 430.24 860.48 900.72		319.75 439.75 879.51 929.27	MHz

f _{Lo}	frequency (8MHz crystal used)	315 MHz band,2.5KHz step 433 MHz band,2.5KHz step 868 MHz band,5KHz step 915 MHz band,7.5KHz step	248.19 344.19 688.38 720.57		255.80 351.80 703.61 743.41	MHz	
f _{Lo}	frequency (12MHz crystal used)	315 MHz band,2.5KHz step 433 MHz band,2.5KHz step 868 MHz band,5KHz step 915 MHz band,7.5KHz step	372.28 516.28 1032.5 1080.8		383.71 527.71 1055.4 1115.1	MHz	
BW	Receiver bandwidth	1 2 3 4 5 6	60 120 180 240 300 360	67 134 200 270 350 400	75 150 225 300 375 450	kHz	
t _{lock}	PLL lock time	After 10MHz step hopping, frequency error <10 kHz		20		us	
T _{st, p}	PLL start time	After crystal stabilized		250		us	
BR	Data rate	With internal digital demodulator			115.2	kbps	
BRA	Data rate	With external RC filter			256	kbps	
P _{min}	sensitivity	BW=134KHz, BR=1.2kbps, 315MHz band BW=134KHz, BR=1.2kbps, 433MHz band BW=134KHz, BR=1.2kbps, 868MHz band BW=134KHz, BR=1.2kbps, 915MHz band		-109 -109 -105 -105	-100 -100 -98 -98	dBm	
AFC _{range}	AFC working range	δF_{fsk} : received signal modulation depth		0.8* δF_{fsk}			
RS _A	RSSI accuracy			±5			dB
RS _R	RSSI range			46			dB
C _{ARSSI}	ARSSI filter			1		nF	
RS _{STEP}	RSSI programmable step			6		dB	
RS _{RESP}	DRSSI response time	RSSI output high after valid , C _{ARRSI} =5nF		500		us	
C _{XL}	Capacitor bank	Programmable step with 0.5pF step, +/- 10%	8.5		16	pF	
T _{POR}	PWR time	V _{dd} reach 90%		50	100	mS	
T _{PBT}	Wakeup timer period	Calibrated each 30s	0. 96		1. 08	mS	
T _{WAKE-UP}	Programmable wakeup time		1		5*10E11	mS	
T _{SX}	Crystal start up time	Crystal ESR < 100 Ohms			5	mS	
C _{IN,D}	Load capacitance				2	pF	
T _{r,F}	Output rising edge	With 15PF load			10	ns	

SMD PACKAGE (S2)

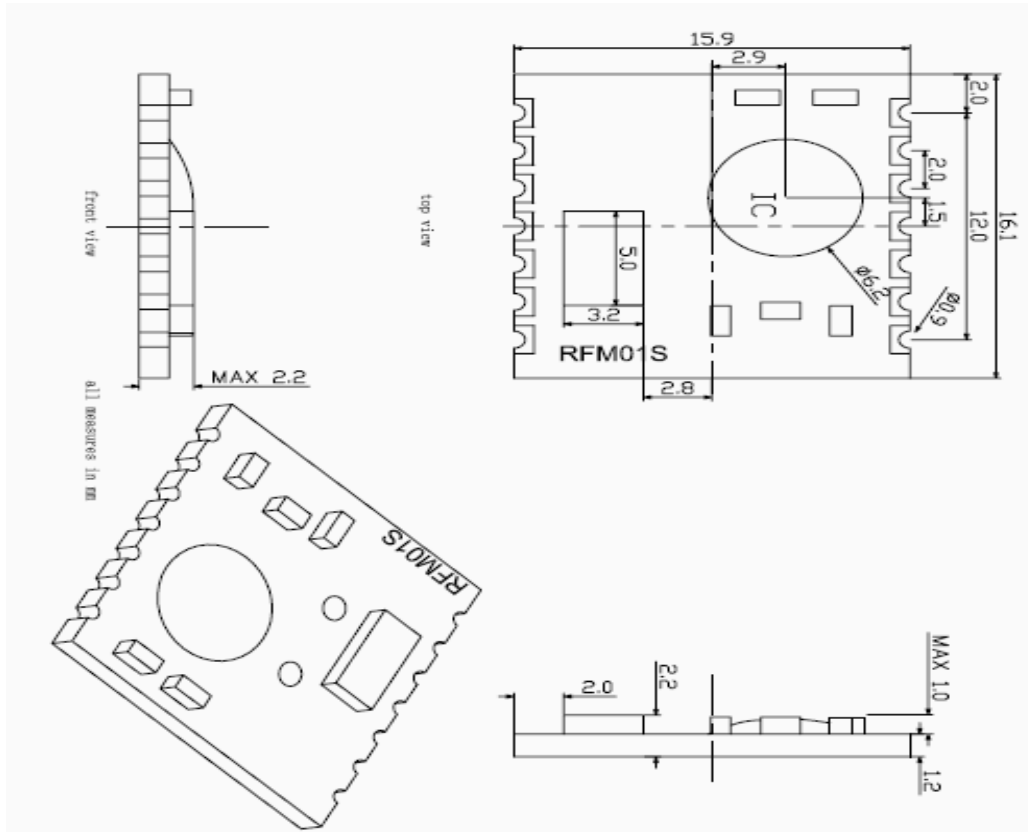

DIP PACKAGE (D)

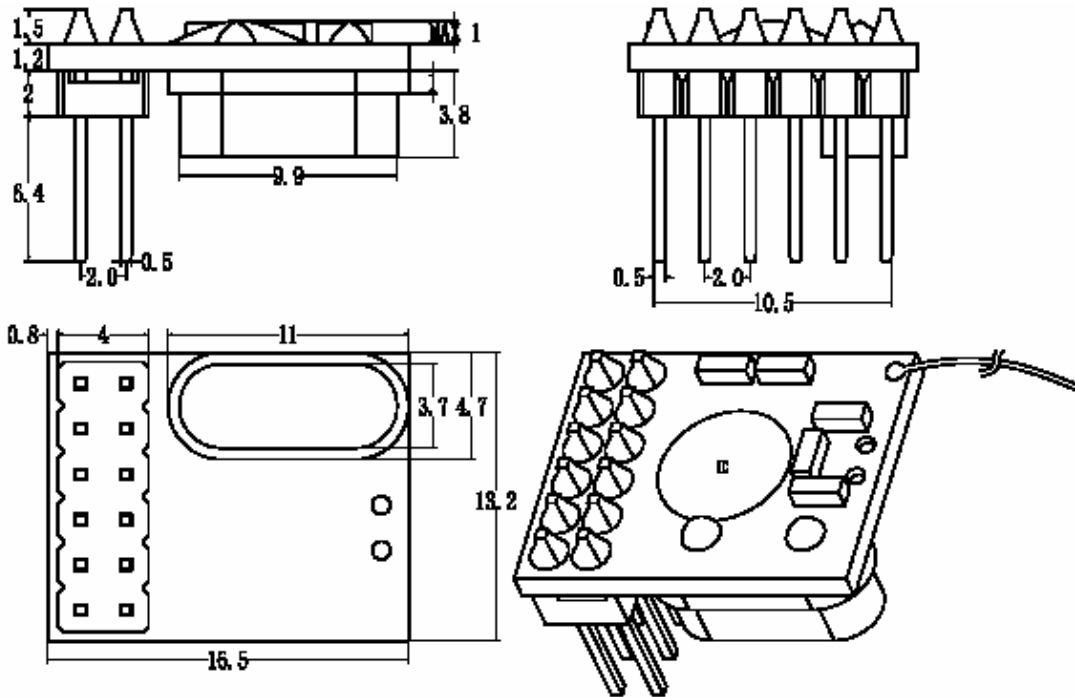

Module Model Definition

model=module-operation_band-package_type

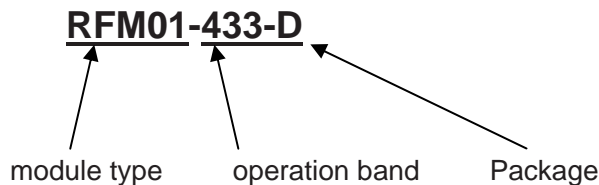

Note: SMD packages is divided into two kinds based on thickness: 1. thickness is 4.2mm, 2. thickness is 2.2mm

example: 1. RFM01 module at 433MHz band ,DIP: RFM01-433-D.

2. RFM01 module at 868MHZ band,SMD, thickness at 4.2mm: RFM01-868-S1.

HOPE MICROELECTRONICS CO.,LTD

Add:4/F, Block B3, East Industrial Area,
Huaqiaocheng, Shenzhen, Guangdong,
China

Tel: 86-755-82973805

Fax: 86-755-82973550

Email: sales@hoperf.com

trade@hoperf.com

Website: <http://www.hoperf.com>

<http://www.hoperf.cn>

<http://hoperf.en.alibaba.com>

This document may contain preliminary information and is subject to change by Hope Microelectronics without notice. Hope Microelectronics assumes no responsibility or liability for any use of the information contained herein. Nothing in this document shall operate as an express or implied license or indemnity under the intellectual property rights of Hope Microelectronics or third parties. The products described in this document are not intended for use in implantation or other direct life support applications where malfunction may result in the direct physical harm or injury to persons. NO WARRANTIES OF ANY KIND, INCLUDING, BUT NOT LIMITED TO, THE IMPLIED WARRANTIES OF MECHANICALITY OR FITNESS FOR A PARTICULAR PURPOSE, ARE OFFERED IN THIS DOCUMENT.

©2006, HOPE MICROELECTRONICS CO.,LTD. All rights reserved.