

W83176R-733

W83176G-733

**Winbond Dual Bank DDR BUFFER
For VIA CHIPSET**

Date: Mar/22/2006 Revision: 1.0

DUAL BANK DDR BUFFER FOR VIA CHIPSET

W83176R-733/W83176G-733 Data Sheet Revision History

	PAGES	DATES	VERSION	WEB VERSION	MAIN CONTENTS
1					All of the versions before 0.50 are for internal use.
2	n.a.	09/09/03	0.5	n.a.	First published preliminary version.
3	3,4,5,8	12/18/03	0.6	n.a.	Correction IC version, correction some description and default value
4		03/22/2006	1.0	1.0	Update on Web and add lead free part
5					
6					
7					
8					
9					
10					

Please note that all data and specifications are subject to change without notice. All the trademarks of products and companies mentioned in this data sheet belong to their respective owners.

LIFE SUPPORT APPLICATIONS

These products are not designed for use in life support appliances, devices, or systems where malfunction of these products can reasonably be expected to result in personal injury. Winbond customers using or selling these products for use in such applications do so at their own risk and agree to fully indemnify Winbond for any damages resulting from such improper use or sales.

DUAL BANK DDR BUFFER FOR VIA CHIPSET

Table of Content-

1.	GENERAL DESCRIPTION	1
2.	PRODUCT FEATURES	1
3.	PIN CONFIGURATION	1
4.	BLOCK DIAGRAM	2
5.	PIN DESCRIPTION.....	3
5.1	Clock Function Pins.....	3
5.2	Control Signal Pins	3
6.	POWER PINS	4
7.	I2C CONTROL AND STATUS REGISTERS	4
7.1	Register 0 ~ Register 5 RESERVED	4
7.2	Register 6: Output Control (1 = Enable, 0 = Disable) (Default: FFh).....	4
7.3	Register 7: Output Control (1 = Enable, 0 = Disable) (Default: FFh).....	4
7.4	REGISTER 8 ~ Register 17 RESERVED	5
7.5	Skew step reference Table	5
7.6	Register 18: Skew Control (Default: 88h).....	5
7.7	Register 19: Skew Control (Default: 80h).....	5
7.8	Slew rate reference table	6
7.9	Register 20: Skew & Slew Rate Control (Default: 8Ah).....	6
7.10	Register 21: Slew Rate Control (Default: AAh)	6
7.11	Register 22: Slew Rate Control (Default: AAh)	6
7.12	Register 23: Slew Rate Control (Default: AAh)	7
8.	ACCESS INTERFACE	8
8.1	Block Write Protocol.....	8
8.2	Block Read Protocol.....	8
8.3	Byte Write Protocol.....	8
8.4	Byte Read Protocol	8
9.	SPECIFICATIONS	9
9.1	ABSOLUTE MAXIMUM RATINGS	9
9.2	AC CHARACTERISTICS.....	9
9.3	DC CHARACTERISTICS	9
10.	ORDERING INFORMATION.....	10
11.	HOW TO READ THE TOP MARKING.....	10
12.	PACKAGE DRAWING AND DIMENSIONS.....	11

DUAL BANK DDR BUFFER FOR VIA CHIPSET

1. GENERAL DESCRIPTION

The W83176R-733 is a 2.5V Dual Bank D.D.R. Clock buffer designed for VIA system. W83176R-733 can support 4 D.D.R. DRAM DIMMs.

The W83176R-733 provides I²C serial bus interface to program the registers to enable or disable each clock outputs. The W83176R-733 accepts a reference clock as its input and runs on 2.5V supply.

2. PRODUCT FEATURES

- Low Skew outputs (< 100ps)
- Two Feedback pins for synchronous for each bank.
- Supports up to 4 D.D.R. DIMMs
- Supports PC3200 D.D.R. SDRAM
- I²C 2-Wire serial interface and supports Byte or Block Date RW
- 48-pin SSOP package

3. PIN CONFIGURATION

VDD2.5	1	48	VDD2.5
GND	2	47	GND
FB_OUTB	3	46	OE_ODD*
BUF_INB	4	45	OE_EVEN*
DDRBT0	5	44	DDRBT2
DDRBC0	6	43	DDRBC2
DDRBT1	7	42	DDRBT3
DDRBC1	8	41	DDRBC3
GND	9	40	GND
VDD2.5	10	39	VDD2.5
DDRAT0	11	38	DDRAT4
DDRAC0	12	37	DDRAC4
DDRAT1	13	36	DDRAT5
DDRAC1	14	35	DDRAC5
GND	15	34	GND
VDD2.5	16	33	VDD2.5
FB_OUTA	17	32	DDRBT4
BUF_INA	18	31	DDRBC4
DDRAT2	19	30	DDRBT5
DDRAC2	20	29	DDRBC5
DDRAT3	21	28	VDD2.5
DDRAC3	22	27	GND
VDD2.5	23	26	SDATA *
GND	24	25	SCLK *

*: Internal pull-up resistor 120K to VDD

DUAL BANK DDR BUFFER FOR VIA CHIPSET

4. BLOCK DIAGRAM

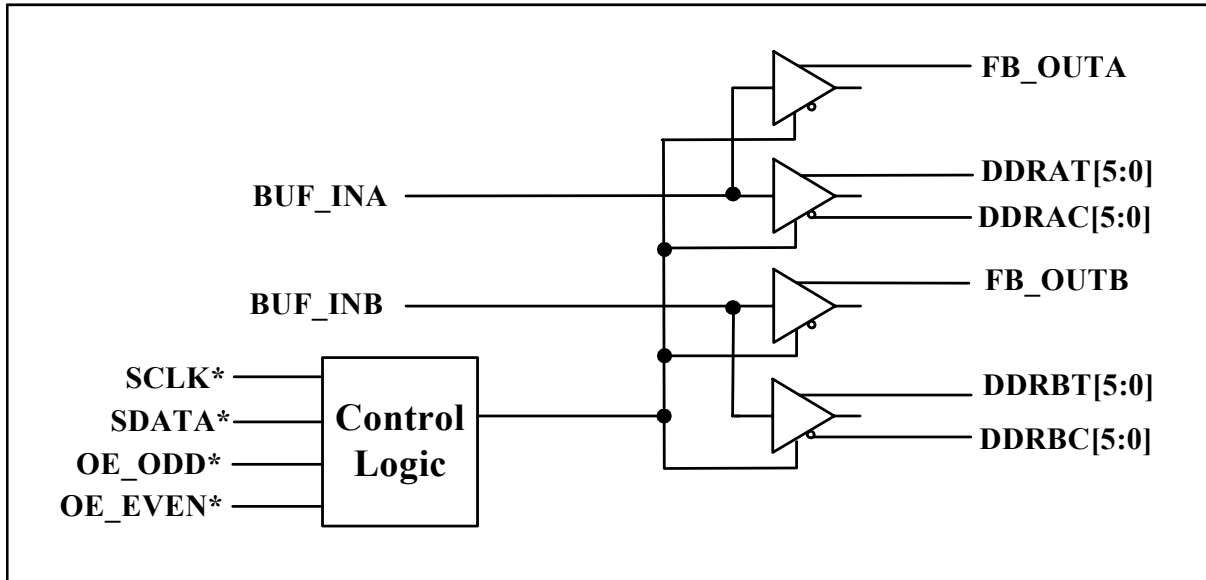

DUAL BANK DDR BUFFER FOR VIA CHIPSET

5. PIN DESCRIPTION

BUFFER TYPE SYMBOL	DESCRIPTION
IN	Input
OUT	Output
I/OD	Bi-directional Pin, Open Drain
*	Internal 120kΩ pull-up

5.1 Clock Function Pins

PIN	PIN NAME	TYPE	DESCRIPTION
18	BUF_INTA	IN	Bank A DDR Buffer True reference clock input.
36,35,38,37,21,22,20,19,14,13,11,12	DDRAT/C [5:0]	OUT	Bank A DDR Buffer clocks of differential pair outputs.
17	FB_OUTA	OUT	Bank A DDR Buffer True Feedback output, dedicated for external feedback.
4	BUF_INTB	IN	Bank B DDR Buffer True reference clock input.
30,29,32,31,42,41,44,43,7,8,5,6	DDRBT/C [5:0]	OUT	Bank B DDR Buffer clocks of differential pair outputs.
3	FB_OUTB	OUT	Bank B DDR Buffer True Feedback output, dedicated for external feedback.

5.2 Control Signal Pins

PIN	PIN NAME	TYPE	DESCRIPTION
26	SDATA *	I/OD	Serial data of I ² C 2-wire control interface Internal pull-up resistor 120K to VDD2.5
25	SCLK *	IN	Serial clock of I ² C 2-wire control interface Internal pull-up resistor 120K to VDD2.5
45	OE_EVEN*	IN	OE_EVEN=1 Enable, OE_EVEN=0 Disable, Even Buffer clock output pairs (DDR0, 2,4), Internal pull-up resistor 120K to VDD2.5
46	OE_ODD*	IN	OE_ODD=1 Enable, OE_ODD=0 Disable, ODD Buffer clock output pairs (DDR1, 3, 5), Internal pull-up resistor 120K to VDD2.5

DUAL BANK DDR BUFFER FOR VIA CHIPSET

6. POWER PINS

PIN	PIN NAME	DESCRIPTION
2,9,15,24,27,34,40,47	GND	Ground
1,10,16,23,28,33,39,48	VDD2.5	Power Supply 2.5V

7. I2C CONTROL AND STATUS REGISTERS

7.1 Register 0 ~ Register 5 RESERVED

7.2 Register 6: Output Control (1 = Enable, 0 = Disable) (Default: FFh)

BIT	PIN NO	PWD	DESCRIPTION
7	Reserved	1	Reserved
6	17	1	FB_OUTA output control
5	36,35	1	DDRA_T5/C5 output control
4	38,37	1	DDRA_T4/C4 output control
3	21,22	1	DDRA_T3/C3 output control
2	20,19	1	DDRA_T2/C2 output control
1	13,14	1	DDRA_T1/C1 output control
0	11,12	1	DDRA_T0/C0 output control

7.3 Register 7: Output Control (1 = Enable, 0 = Disable) (Default: FFh)

Bit	Pin No	PWD	Description
7	Reserved	1	Reserved
6	3	1	FB_OUTB output control
5	30,29	1	DDR_B_T5/C5 output control
4	32,31	1	DDR_B_T4/C4 output control
3	42,41	1	DDR_B_T3/C3 output control
2	44,43	1	DDR_B_T2/C2 output control
1	7,8	1	DDR_B_T1/C1 output control
0	5,6	1	DDR_B_T0/C0 output control

DUAL BANK DDR BUFFER FOR VIA CHIPSET

7.4 REGISTER 8 ~ Register 17 RESERVED

7.5 Skew step reference Table

SKEW<2:0>/<1:0>	DELAY TIME (PS)
000	0
001	250
010	500
011	750
100	1000
101	1250
110	1500
111	1750

7.6 Register 18: Skew Control (Default: 88h)

BIT	NAME	PWD	DESCRIPTION
7	Reserved	1	Reserved
6	DDRA_TSKEW<2>	0	DDRA True clock outputs with FB_OUTA True clock SKEW control bits
5	DDRA_TSKEW<1>	0	
4	DDRA_TSKEW<0>	0	
3	Reserved	1	Reserved
2	DDRA_CSKEW<2>	0	DDRA Complementary clock outputs with FB_OUTA True clock SKEW control bits
1	DDRA_CSKEW<1>	0	
0	DDRA_CSKEW<0>	0	

7.7 Register 19: Skew Control (Default: 80h)

BIT	NAME	PWD	DESCRIPTION
7	Reserved	1	Reserved
6	DDRB_CSKEW<2>	0	DDRB Complementary clock outputs with FB_OUTB True clock SKEW control bits
5	DDRB_CSKEW<1>	0	
4	DDRB_CSKEW<0>	0	
3	FAOUT_SKEW<1>	0	FB_OUTA, DDRA clock outputs with BUF_INA clock SKEW control bits
2	FAOUT_SKEW<0>	0	
1	FBOUT_SKEW<1>	0	FB_OUTB, DDRB clock outputs with BUF_INB clock SKEW control bits
0	FBOUT_SKEW<0>	0	

DUAL BANK DDR BUFFER FOR VIA CHIPSET

7.8 Slew rate reference table

SR<1:0>	STATUS
10/01	Normal (default)
11	Strong
00	Weak

7.9 Register 20: Skew & Slew Rate Control (Default: 8Ah)

BIT	NAME	PWD	DESCRIPTION
7	Reserved	1	Reserved
6	DDRB_TSKEW<2>	0	DDRB True clock outputs with FB_OUTB True clock SKEW control bits
5	DDRB_TSKEW<1>	0	
4	DDRB_TSKEW<0>	0	
3	DDRAT/C0_SR<1>	1	DDRAT/C0 slew rate control bits
2	DDRAT/C0_SR<0>	0	
1	DDRAT/C1_SR<1>	1	DDRAT/C1 slew rate control bits
0	DDRAT/C1_SR<0>	0	

7.10 Register 21: Slew Rate Control (Default: AAh)

BIT	NAME	PWD	DESCRIPTION
7	DDRAT/C2_SR<1>	1	DDRAT/C2 slew rate control bits
6	DDRAT/C2_SR<0>	0	
5	DDRAT/C3_SR<1>	1	DDRAT/C3 slew rate control bits
4	DDRAT/C3_SR<0>	0	
3	DDRAT/C4_SR<1>	1	DDRAT/C4 slew rate control bits
2	DDRAT/C4_SR<0>	0	
1	DDRAT/C5_SR<1>	1	DDRAT/C5 slew rate control bits
0	DDRAT/C5_SR<0>	0	

7.11 Register 22: Slew Rate Control (Default: AAh)

BIT	NAME	PWD	DESCRIPTION
7	DDRBT/C0_SR<1>	1	DDRBT/C0 slew rate control bits
6	DDRBT/C0_SR<0>	0	
5	DDRBT/C1_SR<1>	1	DDRBT/C1 slew rate control bits
4	DDRBT/C1_SR<0>	0	

DUAL BANK DDR BUFFER FOR VIA CHIPSET

Register 22: Slew Rate Control (Default: AAh), continued

BIT	NAME	PWD	DESCRIPTION
3	DDRBT/C2_SR<1>	1	DDRBT/C2 slew rate control bits
2	DDRBT/C2_SR<0>	0	
1	DDRBT/C3_SR<1>	1	DDRBT/C3 slew rate control bits
0	DDRBT/C3_SR<0>	0	

7.12 Register 23: Slew Rate Control (Default: AAh)

BIT	NAME	PWD	DESCRIPTION
7	DDRBT/C4_SR<1>	1	DDRBT/C4 slew rate control bits
6	DDRBT/C4_SR<0>	0	
5	DDRBT/C5_SR<1>	1	DDRBT/C5 slew rate control bits
4	DDRBT/C5_SR<0>	0	
3	FBOUT_SR<1>	1	FB_OUTB slew rate control bits
2	FBOUT_SR<0>	0	
1	FAOUT_SR<1>	1	FB_OUTA slew rate control bits
0	FAOUT_SR<0>	0	

DUAL BANK DDR BUFFER FOR VIA CHIPSET

8. ACCESS INTERFACE

The W83176R-733 provides I²C Serial Bus for microprocessor to read/write internal registers. In the W83176R-733 is provided Block Read/Block Write and Byte-Data Read/Write protocol. **The I²C write address is defined at 0xD4. The I²C read address is defined at 0xD5.**

8.1 Block Write Protocol

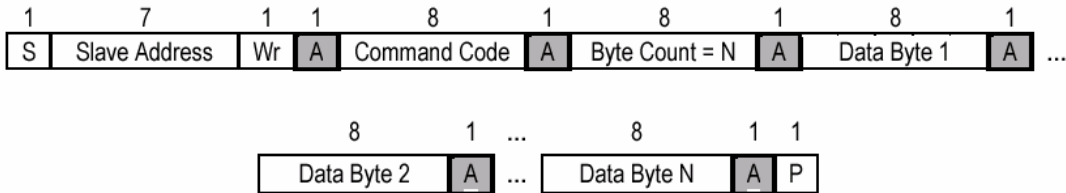

8.2 Block Read Protocol

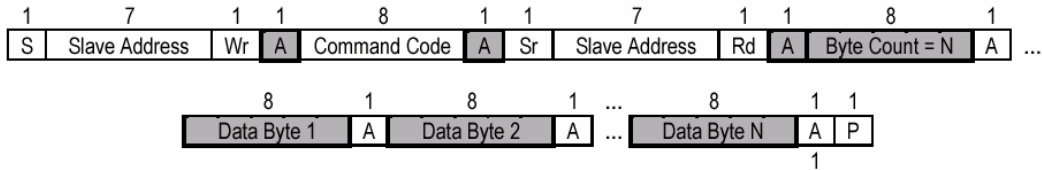

In block mode, the command code must filled '00h'

8.3 Byte Write Protocol

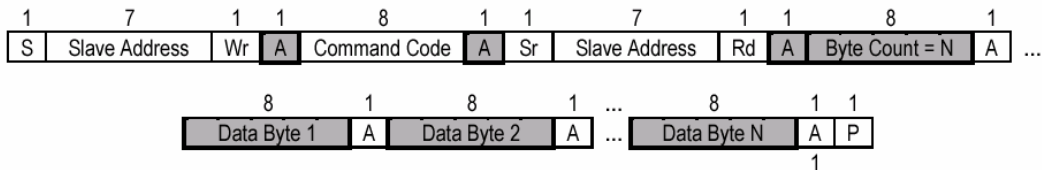

8.4 Byte Read Protocol

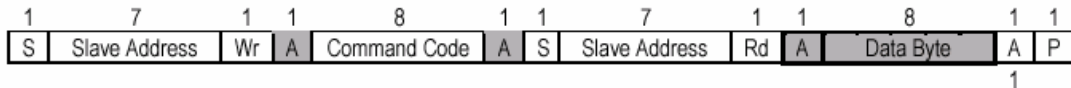

DUAL BANK DDR BUFFER FOR VIA CHIPSET

9. SPECIFICATIONS

9.1 ABSOLUTE MAXIMUM RATINGS

Stresses greater than those listed in this table may cause permanent damage to the device. Precautions should be taken to avoid application of any voltage higher than the maximum rated voltages to this circuit. Maximum conditions for extended periods may affect reliability. Unused inputs must always be tied to an appropriate logic voltage level (Ground or VDD2.5).

PARAMETER	RATING
Voltage on any pin with respect to GND	- 0.5 V to + 3.6 V
Storage Temperature	- 65°C to + 150°C
Ambient Temperature	- 55°C to + 125°C
Operating Temperature	0°C to + 70°C
Input ESD protection (Human body model)	2000V

9.2 AC CHARACTERISTICS

VDD2.5 = 2.5V ± 5 %, T_A = 0°C to +70°C, Test load = 10 pF						
PARAMETER	SYMBOL	MIN	TYP	MAX	UNITS	TEST CONDITIONS
Operating clock frequency	F _{IN}	100		200	MHz	
Input Clock Duty Cycle	D _{tin}	45		55	%	
Dynamic Supply Current	I _{dd}			200	mA	Fin=100 to 200Mhz
Cycle to Cycle Jitter	C-Cjitter			200	ps	Fout=100 to 200Mhz
Output to Output Skew	Tskew			100	ps	Fout=100 to 200Mhz
Output clock Rise time	T _{or}	650		950	ps	Fout=100 to 200Mhz
Output clock Fall time	T _{of}	650		950	ps	Fout=100 to 200Mhz
Output clock Duty Cycle	D _{tot}	45		55	%	Fout=100 to 200Mhz
Output differential-pair crossing voltage	V _{oc}	(V _{dd} /2) -0.2	V _{dd} / 2	(V _{dd} /2) + 0.2	V	Fout=100 to 200Mhz

9.3 DC CHARACTERISTICS

VDD2.5= 2.5V ± 5 %, T_A = 0°C to +70°C						
PARAMETER	SYMBOL	MIN	TYP	MAX	UNITS	TEST CONDITIONS
SDATA, SCLK Input Low Voltage	SV _{IL}			1.0	V _{dc}	
SDATA, SCLK Input High Voltage	SV _{IH}	2.2			V _{dc}	
BUF_IN Input Voltage Low	V _{IL}			0.4	V _{dc}	Fin=100 to 200Mhz
BUF_IN Input Voltage High	V _{IH}	2.1			V _{dc}	Fin=100 to 200Mhz
Input Pin Capacitance	C _{IN}			5	pF	
Output Pin Capacitance	C _{OUT}			6	pF	
Input Pin Inductance	L _{IN}			7	nH	

DUAL BANK DDR BUFFER FOR VIA CHIPSET

10. ORDERING INFORMATION

PART NUMBER	PACKAGE TYPE	PRODUCTION FLOW
W83176R-733	48 PIN SSOP	Commercial, 0°C to +70°C
W83176G-733	48 PIN SSOP(Lead free part)	Commercial, 0°C to +70°C

11. HOW TO READ THE TOP MARKING

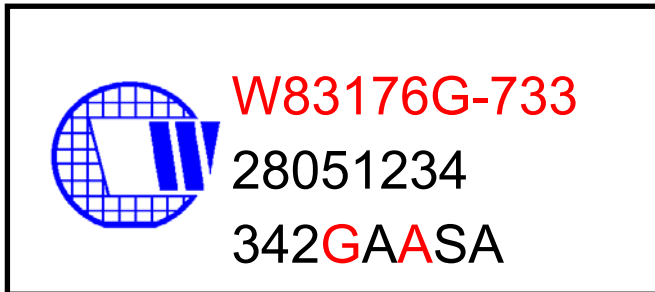
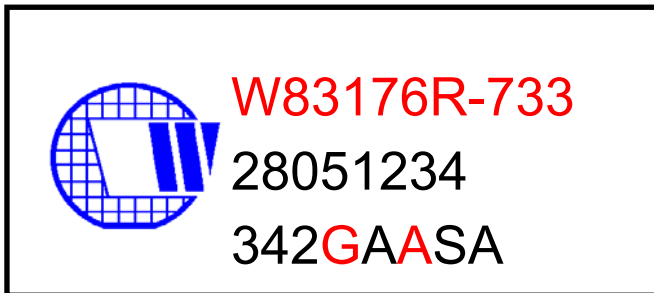

1st line: Winbond logo and the type number:

Normal:W83176R-733, Lead free part: W83176G-733

2nd line: Tracking code 2 8051234

2: wafers manufactured in Winbond FAB 2

8051234: wafer production series lot number

3rd line: Tracking code 342 G E D SA

342: packages made in '2003, week 42

G: assembly house ID; O means OSE, G means GR

A: Internal use code

A: IC revision

SA: Internal use code

All the trade marks of products and companies mentioned in this data sheet belong to their respective owners.

DUAL BANK DDR BUFFER FOR VIA CHIPSET

12. PACKAGE DRAWING AND DIMENSIONS

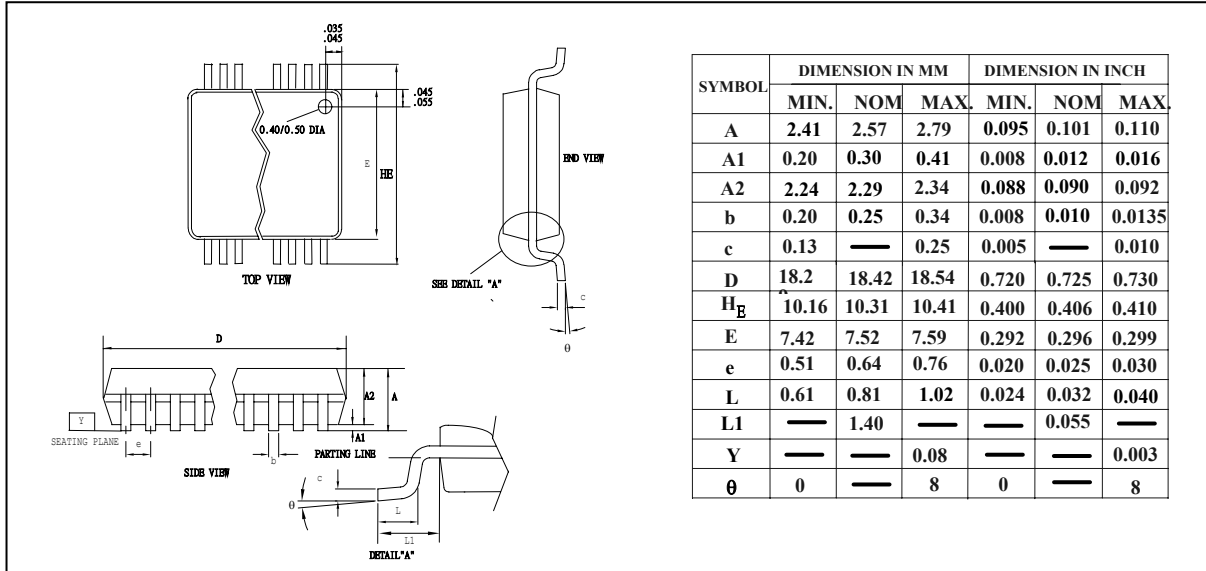

Please note that all data and specifications are subject to change without notice. All the trade marks of products and companies mentioned in this data sheet belong to their respective owners.

Important Notice

Winbond products are not designed, intended, authorized or warranted for use as components in systems or equipment intended for surgical implantation, atomic energy control instruments, airplane or spaceship instruments, transportation instruments, traffic signal instruments, combustion control instruments, or for other applications intended to support or sustain life. Further more, Winbond products are not intended for applications wherein failure of Winbond products could result or lead to a situation wherein personal injury, death or severe property or environmental damage could occur.

Winbond customers using or selling these products for use in such applications do so at their own risk and agree to fully indemnify Winbond for any damages resulting from such improper use or sales.



Headquarters
 No. 4, Creation Rd. III,
 Science-Based Industrial Park,
 Hsinchu, Taiwan
 TEL: 886-3-5770066
 FAX: 886-3-5665577
<http://www.winbond.com.tw/>

Taipei Office
 9F, No.480, Rueiguang Rd.,
 Neihu District, Taipei, 114,
 Taiwan, R.O.C.
 TEL: 886-2-8177-7168
 FAX: 886-2-8751-3579

Winbond Electronics Corporation America
 2727 North First Street, San Jose,
 CA 95134, U.S.A.
 TEL: 1-408-9436666
 FAX: 1-408-5441798

Winbond Electronics Corporation Japan
 7F Daini-ueno BLDG, 3-7-18
 Shinyokohama Kohoku-ku,
 Yokohama, 222-0033
 TEL: 81-45-4781881
 FAX: 81-45-4781800

Winbond Electronics (Shanghai) Ltd.
 27F, 2299 Yan An W. Rd. Shanghai,
 200336 China
 TEL: 86-21-62365999
 FAX: 86-21-62365998

Winbond Electronics (H.K.) Ltd.
 Unit 9-15, 22F, Millennium City,
 No. 378 Kwun Tong Rd.,
 Kowloon, Hong Kong
 TEL: 852-27513100
 FAX: 852-27552064

*Please note that all data and specifications are subject to change without notice.
 All the trade marks of products and companies mentioned in this data sheet belong to their respective owners.*