

CMOS EPL Series 20 A/B

RICOH EPL Series 20A/B are field-programmable logic arrays made possible by CMOS EPROM process technology.

Two product groups make up the EPL Series 20 A/B family.

Group I consists of AND-FIXED OR, XOR arrays, (EPL 10P8, 12P6, 14P4, and 16P2) available in 55ns or 35ns versions.

Group II consists of AND-FIXED OR, XOR array (EPL 16P8) and three Registered AND-FIXED OR, XOR arrays (EPL 16RP8, 16RP6, and 16RP4).

EPL Series 20A/B devices allow users to program by writing into EPROM Memory Cells. Series 20A/B are available in both one-shot plastic packages and reprogrammable Cerdip window packages.

Therefore, it is possible to shorten the development time and check and correct the circuits easily.

Features

- CMOS process technology ensures low power consumption and higher reliability
- Available in both Plastic and Cerdip window packages
- Data copying protection
- Flexibility of logic structure
- Package Type: 20-pin 300 mil Plastic DIP (one-shot)
20-pin 300 mil Ceramic DIP with a window (reprogrammable)
- Product Term: 32 (Group I)
64 (Group II)
- Propagation Delay Time:
55ns (max): Series 20 A
35ns (max): Series 20 B
- Each pin has programmable output polarity
- Upward compatibility with MMI devices, PAL™

EPL Series 20 A/B Family

Part Number		Configuration
Group I (A and B)	EPL 10P8	10-Input, 8-Output, AND-OR, XOR array
	EPL 12P6	12-Input, 6-Output, AND-OR, XOR array
	EPL 14P4	14-Input, 4-Output, AND-OR, XOR array
	EPL 16P2	16-Input, 2-Output, AND-OR, XOR array
Group II (‘B’ only)	EPL 16P8	10-Input, 6-I/O, 8-Output AND-OR, XOR array
	EPL 16RP8	8-Input, 8-Feedback, 8-Output, 8-Registered AND-OR, XOR array
	EPL 16RP6	8-Input, 6-Feedback, 2-I/O, 6-Output, 6-Registered AND-OR, XOR array
	EPL 16RP4	16-Input, 8-Input, 4-Feedback, 4-I/O, 4-Output, 4-Registered AND-OR, XOR array

Part Numbering System

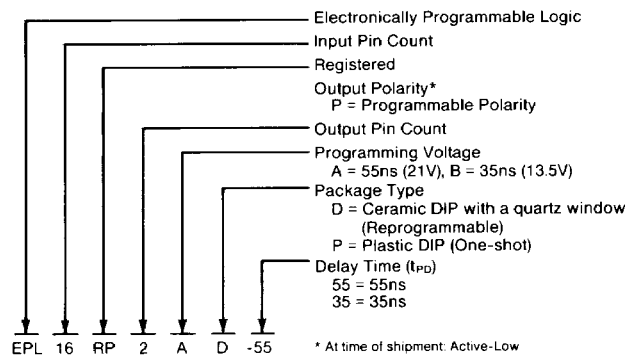

Logic Outlines Group I

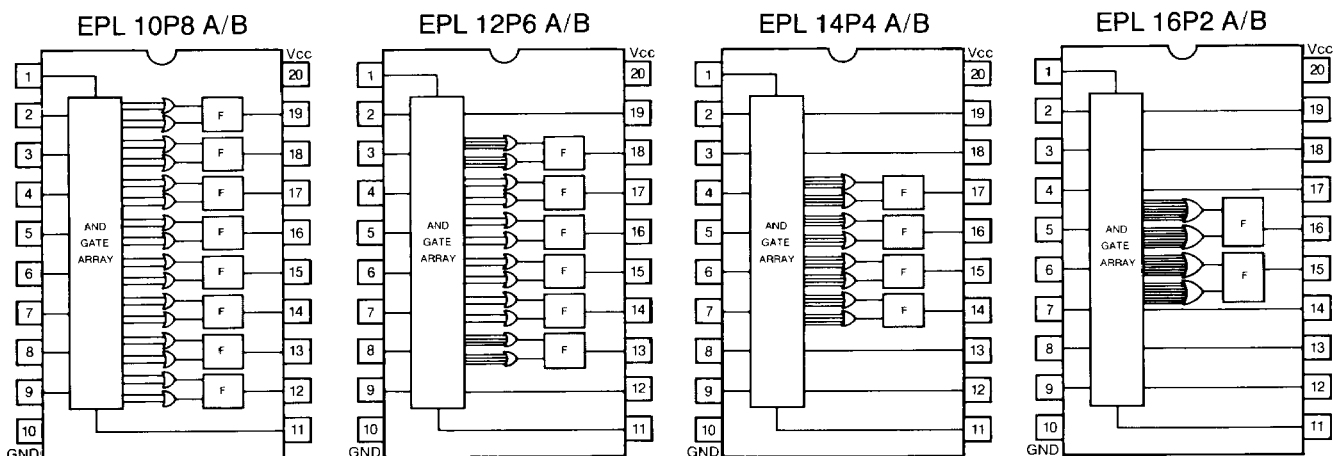

Group II

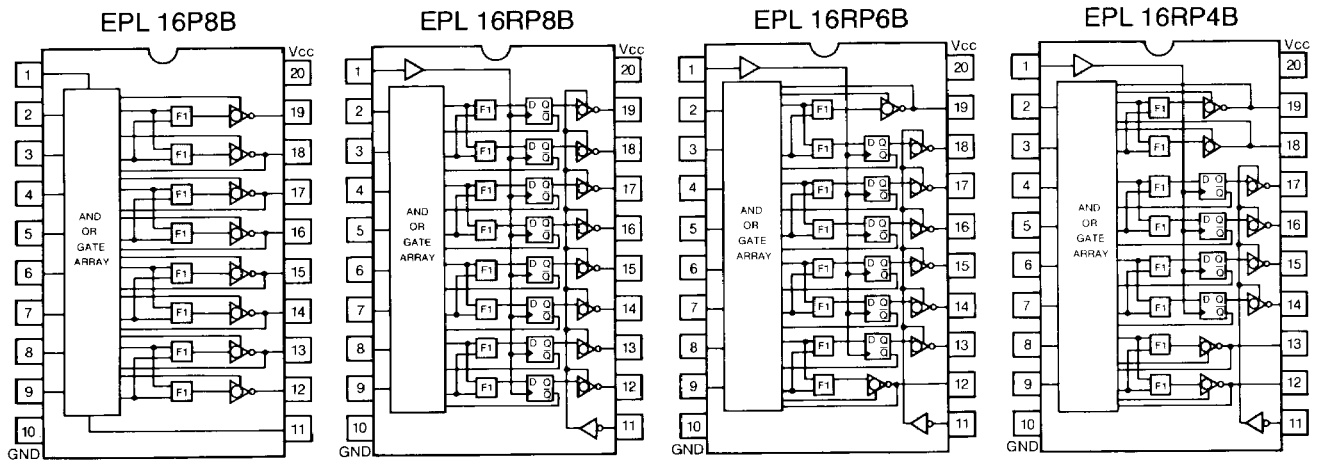

NOTE: F - Feature Cell (OR, XOR, Polarity)

F1 - Feature1 Cell (OR, XOR)

Feature2 Cell (Polarity)

Electrical Specifications
Absolute Maximum Ratings

Symbol	Item	Condition	Rated Value	Unit
V _{CC}	V _{CC} supply voltage	With respect to GND	-0.3 to 7	V
V _{PP}	V _{PP} supply voltage		A = -0.3 to 22.0, B = -0.3 to 14.5	V
V _I	Input voltage		-0.3 to V _{CC} + 0.3	V
V _O	Output voltage		-0.3 to V _{CC} + 0.3	V
P _D	Max. power consumption	T _a = 25°C	700	mW
T _{OPR}	Ambient operating temperature		0 to 70	°C
T _{STG}	Storage temperature		-40 to 125	°C

EPL Series 20A D.C. Characteristics (T_a = 0 to 70°C, V_{CC} = 5V ± 5%)

Symbol	Item	Condition	Min.	Typ.	Max.	Unit
I _{LI}	Input current leakage	V _{IN} = 0V to V _{CC}	-20		20	μA
V _{IL}	"L" input voltage		-0.3		0.8	V
V _{IH}	"H" input voltage		2.0		V _{CC} + 0.3	V
V _{OL}	"L" output voltage	V _{CC} = MIN, I _{OL} = 8mA*		0.3	0.5	V
V _{OH}	"H" output voltage	V _{CC} = MIN, I _{OH} = 3.2mA*	2.4	4.4		V
I _{CC1}	Supply current (Static)	Group I V _{CC} = MAX, Output = open V _I = GND or V _{CC} *		5.5	25	mA
			V _{CC} = MAX, Output = open V _I = 2.4V			35
I _{CC2}	Supply current (Active)	Group I V _{CC} = MAX, Output = open f = 10MHz, V _I = 0.8V or 2.4V*		8	45	mA

EPL Series 20B D.C. Characteristics (Ta = 0 to 70°C, Vcc = 5V ± 5%)

Symbol	Item	Condition	Min.	Typ.	Max.	Unit
I _{LI}	Input current leakage	V _{IN} = 0V to V _{CC}	-20		20	μA
V _{IL}	"L" input voltage		-0.3		0.8	V
V _{IH}	"H" input voltage		2.0		V _{CC} + 0.3	V
V _{OL}	"L" output voltage	V _{CC} = MIN, I _{OL} = 8mA**		0.3	0.5	V
V _{OH}	"H" output voltage	V _{CC} = MIN, I _{OH} = 3.2mA**	2.4	4.4		V
I _{LO}	Output current leakage in OFF status	Group II V _O = 0V to V _{CC}	-20		20	μA
I _{CC1}	Supply current (Static)	Group I	V _{CC} = MAX, Output open V _I = GND or V _{CC} *	10	40	mA
			V _{CC} = MAX, Output = open V _I = 2.4V		50	mA
		Group II	V _{CC} = MAX, Output = open V _I = GND or V _{CC} *	35	60	mA
			V _{CC} = MAX, Output = open V _I = 2.4V		70	mA
I _{CC2}	Supply current (Active)	Group I	V _{CC} = MAX, Output = open	15	60	mA
		Group II	f = 10MHz, V _I = 0.8V or 2.4V*	40	80	mA

NOTES: Group I devices are equipped with power-down circuits. When neither "OR" nor "XOR" in the FEATURE cell is used, current for the unused product term is cut off. (Above mentioned specifications are conditional on the use of all product terms.)

*Typical I_{CC} values are for V_{CC} = 5.0V, 50% product term usage, Ta = 25°C

**Typical V_{OL} = 0.5V for I_{OL} = 16mA, Ta = 25°C

EPL Series 20A A.C. Characteristics (Ta = 0 to 70°C, Vcc = 5V ± 5%)

Symbol	Item	Condition	Min.	Typ.	Max.	Unit
t _{PD}	Input or feedback to output	R ₁ = 560Ω		45	55	ns
f _{MAX}	Max. frequency	R ₂ = 1.1KΩ C _L = 50pF			16	MHz

EPL Series 20B A.C. Characteristics (Ta = 0 to 70°C, Vcc = 5V ± 5%)

Symbol	Item		Condition	Typical			Unit	
				Min.	Std.	Max.		
t _{PD}	Propa- gation Delay Time	Input or feedback to output	R ₁ = 560Ω R ₂ = 1.1KΩ C _L = 50pF		25	35	ns	
t _{CLK}		Clock to output or feedback			15	25	ns	
t _{PZX}		Pin11 to output enable			15	25	ns	
t _{PXZ}		Pin11 to output disable			15	25	ns	
t _{PIZ}		Input to output enable			25	35	ns	
t _{PIX}		Input to output disable			25	35	ns	
f _{MAX}		Max. frequency					20	MHz
t _{WL}		Minimum clock time width		Low		20		ns
t _{WH}				High		20		ns
t _{SU}		Input set-up time				25		ns
t _H	Input hold time			0		ns		

Output Load

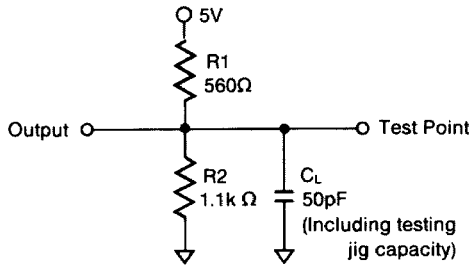

Input Waveform

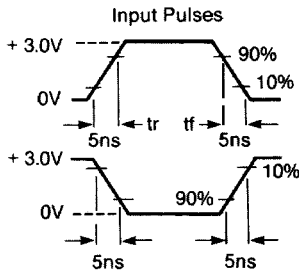

NOTE: This is the A.C. characteristic measurement with a voltage of 1.5 V on both the input and output.

Logic Diagram

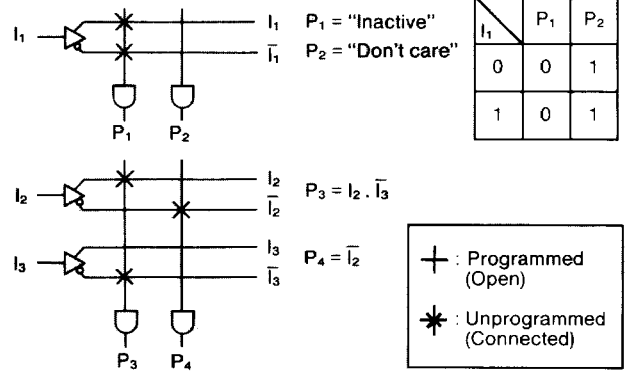
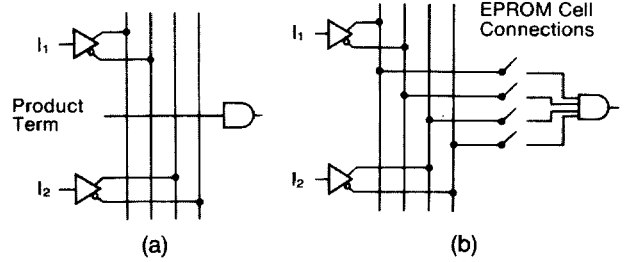

(c)

Configurations of EPL Logic

Ricoh EPL Series 20 A/B. Group I provides 32 input addresses and 32 product terms. Ricoh EPL Series 20 A/B Group II provides 32 input terms and 64 product terms. Input pins in both groups operate at TTL levels.

All intersection points of the input addresses and product terms are provided with an EPROM cell connection. These intersections are connected prior to delivery.

The AND gate is illustrated in logic diagram (a) above. The switches, indicated in logic diagram (b) correspond to the EPROM cell connections. All switches are closed when the devices are unprogrammed.

As illustrated in logic diagram (c), when neither positive input (I) nor negative input (I) is programmed, the AND output (P₁) becomes "inactive." When both positive input (I) and negative input (I) are programmed, the AND output (P₂) becomes "don't care" logically.

Each output includes a FEATURE cell in addition to the programmable AND-FIXED OR logic. The FEATURE cell enables the user to program the logic polarity (active-high/active-low) and the logical OR, Exclusive-OR case.

Timing Diagram

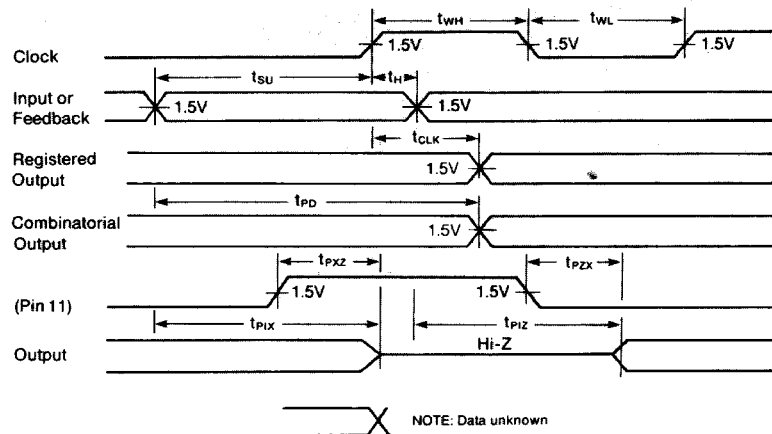

NOTE: Data unknown

Group I
Block Diagram

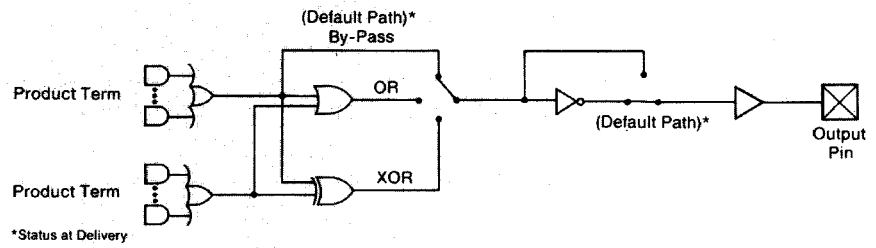

Group II
I/O Block Diagram

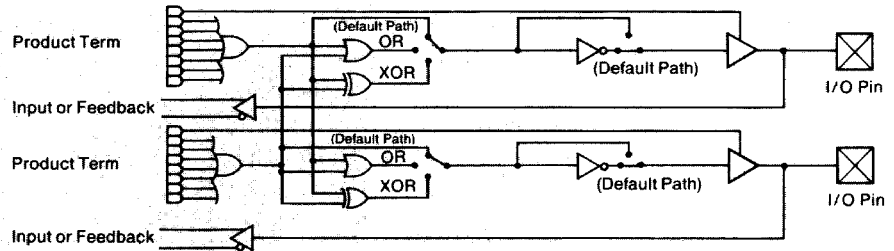

Group II
Registered Block Diagram

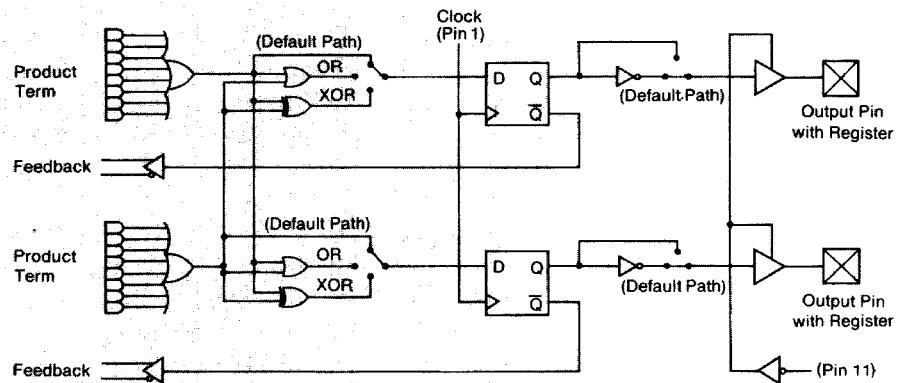

Feature Cell (MMI PAL and pin compatible)

Feature 1
OR/XOR

Unprogrammed
State (MMI PAL
pin compatible)

Unprogrammed State → Final State

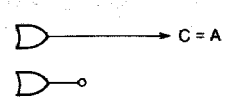
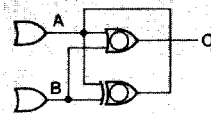

OR Program

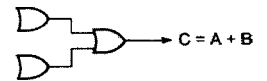
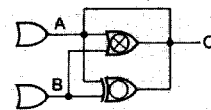

XOR Program

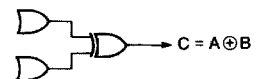
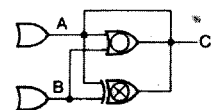

Feature 2
POLARITY

Unprogrammed
State

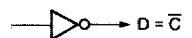

POLARITY Program



Programming Modes

Ricoh EPL Series A/B go into the program/verify mode when Pin 1 (V_{PP}) has V_{IHP} (20A : 21V, 20B : 13.5V) applied.

Two program/verify modes exist to program/verify the AND array and to program/verify the FEATURE CELL.

AND Array	Programming	Verification
(See AND Array Timing Diagram)	<ul style="list-style-type: none"> ■ Apply V_{IHP} (20A : 21V, 20B : 13.5V) to Pin 1 (V_{PP}) ■ Set Address A0-A7 ■ Set Data D0-D7 Data "L" is programmed Data "H" is not programmed ■ Execute program by applying each 1ms pulse of V_{IHH} (20A : 15V, 20B : 13.5V) to Pin 11 (PGM/OE), as illustrated in following flow chart 	<ul style="list-style-type: none"> ■ Apply V_{IHP} (20A : 21V, 20B : 13.5V) to Pin 1 (V_{PP}) ■ Set Address A0-A7 ■ Verify Data D0-D7 with Pin 11 (PGM/OE) set to V_{IL}

Feature Cell	Programming	Verification
	<ul style="list-style-type: none"> ■ Apply V_{IHP} (20A : 21V, 20B : 13.5V) to Pin 1 (V_{PP}) ■ Apply V_{IHH} (20A : 15V, 20B : 13.5V) to Pin 5 (FPM) ■ Select Feature Cell Attributes via Pin 3 (S1) and Pin 4 (S2) (See table 2) ■ Set Feature Cell Data Data "L" is programmed Data "H" is not programmed ■ Execute program by applying each 1ms pulse of V_{IHH} (20A : 15V, 20B : 13.5V) to Pin 11 (PGM/OE) as illustrated in following flow chart 	<ul style="list-style-type: none"> ■ Apply V_{IHP} (20A : 21V, 20B : 13.5V) to Pin 1 (V_{PP}) ■ Apply V_{IHH} (20A : 15V, 20B : 13.5V) to Pin 5 (FPM) ■ Select Feature Cell Attributes via Pin 3 (S1) and Pin 4 (S2) (See table 2) ■ Set Pin 11 (PGM/OE) to "V_{IL}" Level

Security Cell	Programming	Verification
	<ul style="list-style-type: none"> ■ Apply V_{IHP} (20A : 21V, 20B : 13.5V) to Pin 1 (U_{PP}) ■ Apply V_{IHH} (20A : 15V, 20B : 13.5V) to Pin 5 (FPM) ■ Set "L" Level to Pin 12 (D0/Security) ■ Execute Security Program by applying 50ms pulse and V_{IHH} (20A : 15V, 20B : 13.5V) to Pin 11 (PGM/OE) 	

Table 2

S1	S2	Feature Cell
0	0	OR
0	1	XOR
1	0	Polarity
1	1	Security

0 : V_{IL}
1 : V_{IH}

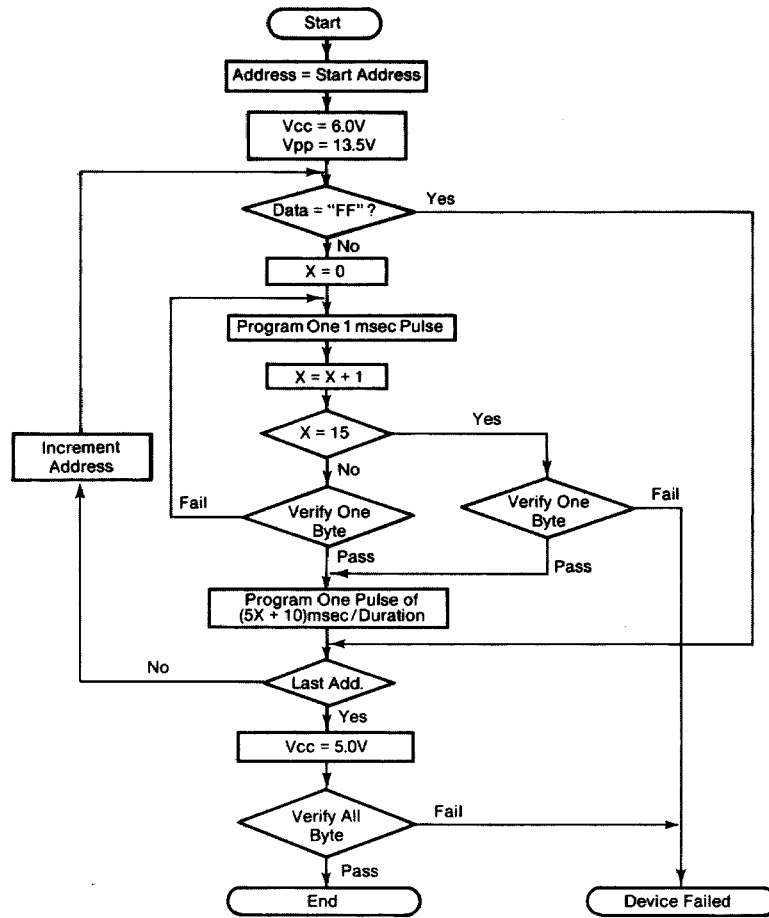

Timing Diagram

1. AND Array* Programming/Verification

2. Feature Cell* Programming/Verification

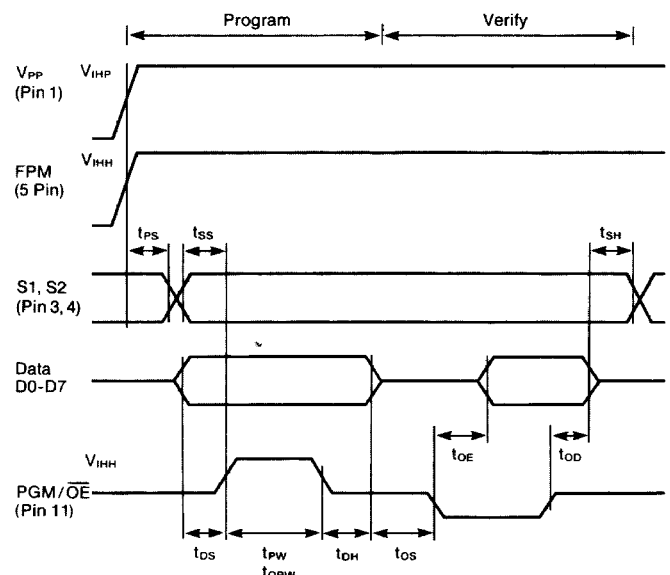
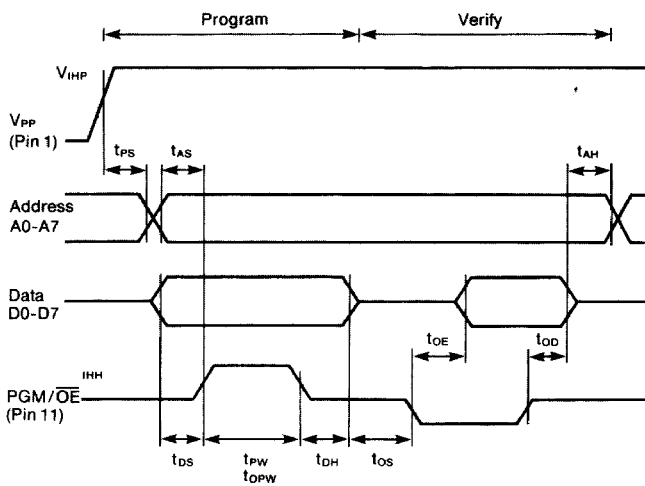

Preload Mode: EPL 16RP8, EPL 16RP6, EPL 16RP4

The data of each pin is preloaded to F/F with the steps in the table below.

Preload Mode	Read
<ul style="list-style-type: none"> ■ Apply V_{IL} to Pin 1 (CLK) ■ Apply V_{IH} to Pin 11 (OE) ■ Set the preload data to the data pin ■ Apply the preload pulse of 2μs pulse width of V_{IHH} (20A : 15V, 20B : 13.5V) to Pin 4 (PRELOAD/S2/A5) 	Same F/F Read operation as in normal logic mode

Timing Diagram

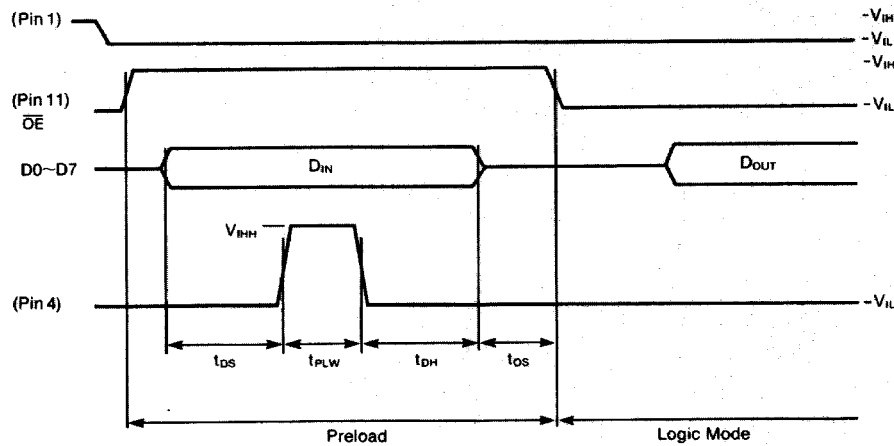

Programming Electrical Specifications
 D.C. Attributes (TA = 20 ~ 30°C, Vcc = 6.0 ± 0.25V)

Symbol	Item	Requirements	Typical			Unit
			Min.	Avg.	Max.	
I_{LI}	Input leakage current	$V_I = 0V \sim V_{CC}$	-20		20	μA
I_{LO}	Output leakage current	$V_O = 0V \sim V_{CC}$	-20		20	μA
V_{IL}	Input voltage "L"		-0.3		0.8	V
V_{IH}	Input voltage "E"		2.5		$V_{CC} + 0.3$	V
V_{IHH}	Programmed input voltage "H"-Series 20A		14.5	15.0	15.5	V
V_{IHH}	Programmed input voltage "H"-Series 20B		13.0	13.5	14.0	V
V_{IHP}	Programmed supply voltage-Series 20A		20.5	21.0	21.5	V
V_{IHP}	Programmed supply voltage-Series 20B		13.0	13/5	14.0	V
I_{HH}	Programmed power source current- V_{IHH}	PGM/OE, FPM = V_{IHH}			5	mA
I_{HP}	Programmed power source current- V_{IHP}	$V_{PP} = V_{IHP}$			30	mA
I_{CC}	Programmed power source current- V_{CC}				5	mA

A.C. Attributes (TA = 20 ~ 30°C, Vcc = 6.0 ± 0.25V)

Symbol	Item	Min.	Avg.	Max.	Unit
t _{PS}	V _{IHP} set-up time	2			μS
t _{AS}	Address set-up time	2			μS
t _{DS}	Data set-up time	2			μS
t _{PW}	Program pulse width	0.95	1.0	1.05	mS
t _{DH}	Data hold time	2			μS
t _{OS}	OE set-up time	2			μS
t _{OE}	OE access time			2	μS
t _{OO}	Data effective time after OE	0		2	μS
t _{AH}	Address hold time	2			μS
t _{SS}	Select set-up time	2			μS
t _{SH}	Select hold time	2			μS
t _{PLW}	Preload pulse width	2			μS
t _{OPW}	Over pulse width	14.75		88.75	μS

Pin Layout Diagram
Program Mode

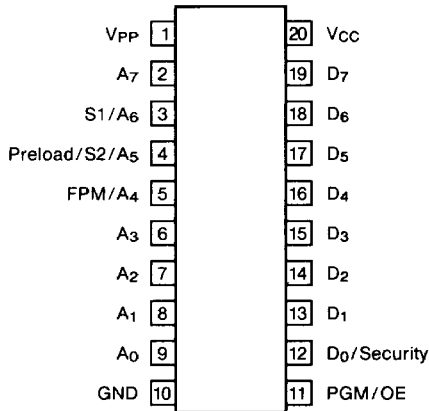

Mode Table

Pin Connection/Function Definitions											
	1	2	3	4	5	6	7	8	9	11	12-19
AND Array Program	HP	A7	A6	A5	A4	A3	A2	A1	A0	HH	Data Input
AND Array Verify	HP	A7	A6	A5	A	A3	A2	A1	A0	L	Data Output
Feature Program	HP	X	S1	S2	HH	X	X	X	X	HH	Data Input
Feature Verify	HP	X	S1	S2	HH	X	X	X	X	L	Data Output
Preload	L	X	X	HH	X	X	X	X	X	H	Data Input
Logic Mode	All Inputs are TTL Level										

NOTES: HP = V_{IHP} (Series 20A : 21V, Series 20B : 13.5V)
 HH = V_{IHH} (Series 20A : 15V, Series 20B : 13.5V)
 H = V_{IH}
 L = V_{IL}
 X = Don't care (TTL Level)

Programmer Support

Manufacturer	Programmer	RICOH EPL Personality Module
Data I/O	Model 29B, Model 60	Universal CMOS PAL Adapter 303A - 011A
Minato Electronics	Model 1870A	7SP-REPL20
Valley Data Sciences	150/160 Series	None
Stag	ZL30	None
Oliver	OMNI	None

NOTE: Other programmer vendors to be announced.

Support Software

Manufacturer	Name of Software	Operating System
Data I/O	ABEL™	MS-DOS™ DEC VAX/VMS™ DEC VAX/UNIX™
Assisted Technology	CUPL™	MS-DOS CP/M-86™ DEC VAX/VMS DEC VAX/UNIX
RICOH	EPLASM™	MS-DOS VAX/VMS

Address Table - Group I
Input Line No. vs. Address

Input Line Number	Address Pin State				
	A4	A3	A2	A1	A0
0	0	0	0	0	0
1	0	0	0	0	1
2	0	0	0	1	0
3	0	0	0	1	1
4	0	0	1	0	0
5	0	0	1	0	1
6	0	0	1	1	0
7	0	0	1	1	1
8	0	1	0	0	0
9	0	1	0	0	1
10	0	1	0	1	0
11	0	1	0	1	1
12	0	1	1	0	0
13	0	1	1	0	1
14	0	1	1	1	0
15	0	1	1	1	1
16	1	0	0	0	0
17	1	0	0	0	1
18	1	0	0	1	0
19	1	0	0	1	1
20	1	0	1	0	0
21	1	0	1	0	1
22	1	0	1	1	0
23	1	0	1	1	1
24	1	1	0	0	0
25	1	1	0	0	1
26	1	1	0	1	0
27	1	1	0	1	1
28	1	1	1	0	0
29	1	1	1	0	1
30	1	1	1	1	0
31	1	1	1	1	1

Address Table - Group II
Input Line No. vs. Address

Input Line Number	Address Pin State				
	A4	A3	A2	A1	A0
0	1	1	1	1	1
1	1	1	1	1	0
2	0	0	0	0	1
3	0	0	0	0	0
4	1	1	1	0	1
5	1	1	1	0	0
6	0	0	0	1	1
7	0	0	0	1	0
8	1	1	0	1	1
9	1	1	0	1	0
10	0	0	1	0	1
11	0	0	1	0	0
12	1	1	0	0	1
13	1	1	0	0	0
14	0	0	1	1	1
15	0	0	1	1	0
16	1	0	1	1	1
17	1	0	1	1	0
18	0	1	0	0	1
19	0	1	0	0	0
20	1	0	1	0	1
21	1	0	1	0	0
22	0	1	0	1	1
23	0	1	0	1	0
24	1	0	0	1	1
25	1	0	0	1	0
26	0	1	1	0	1
27	0	1	1	0	0
28	1	0	0	0	1
29	1	0	0	0	0
30	0	1	1	1	1
31	0	1	1	1	0

NOTES: 1. An unspecified input line will produce all low data.
2. (A7) Pin 2 must be at V_L for Group I EPLs.

Product Line No. vs. Address

Product Line Number								Address Pin State		
D0	D1	D2	D3	D4	D5	D6	D7	A7	A6	A5
56	48	40	32	24	16	8	0	0	0	0
57	49	41	33	25	17	9	1	0	0	1
58	50	42	34	26	18	10	2	0	1	0
59	51	43	35	27	19	11	3	0	1	1
60	52	44	36	28	20	12	4	1	0	0
61	53	45	37	29	21	13	5	1	0	1
62	54	46	38	30	22	14	6	1	1	0
63	55	47	39	31	23	15	7	1	1	1

Product Line No. vs. Address

Product Line Number								Address Pin State		
D0	D1	D2	D3	D4	D5	D6	D7	A7	A6	A5
56	48	40	32	24	16	8	0	0	0	0
57	49	41	33	25	17	9	1	0	0	1
58	50	42	34	26	18	10	2	0	1	0
59	51	43	35	27	19	11	3	0	1	1
60	52	44	36	28	20	12	4	1	0	0
61	53	45	37	29	21	13	5	1	0	1
62	54	46	38	30	22	14	6	1	1	0
63	55	47	39	31	23	15	7	1	1	1

☐ : Area not in use

Logic Diagram
 EPL10P8A
 EPL10P8B

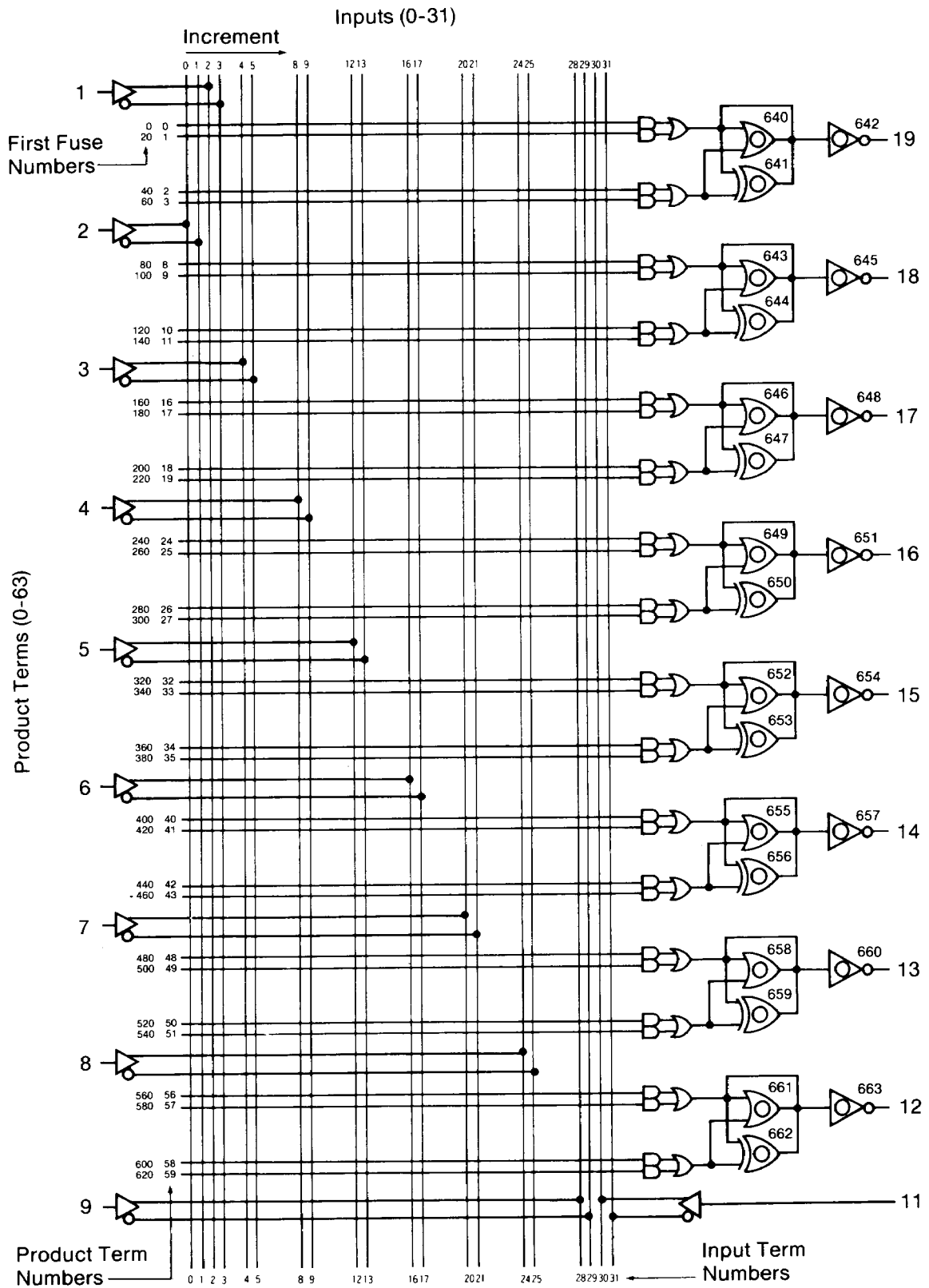

Logic Diagram
 EPL12P6A
 EPL12P6B

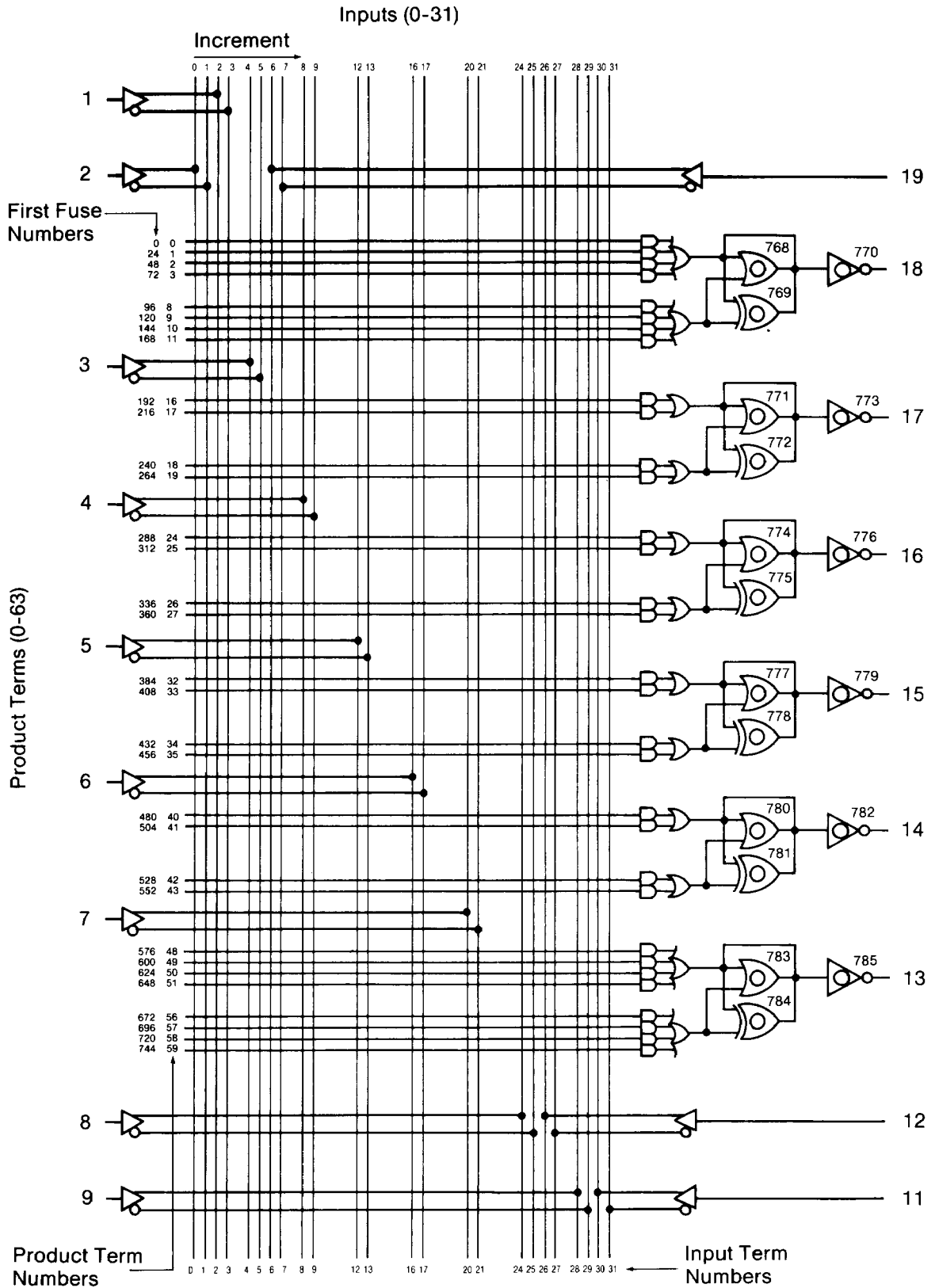

Logic Diagram
EPL14P4A
EPL14P4B

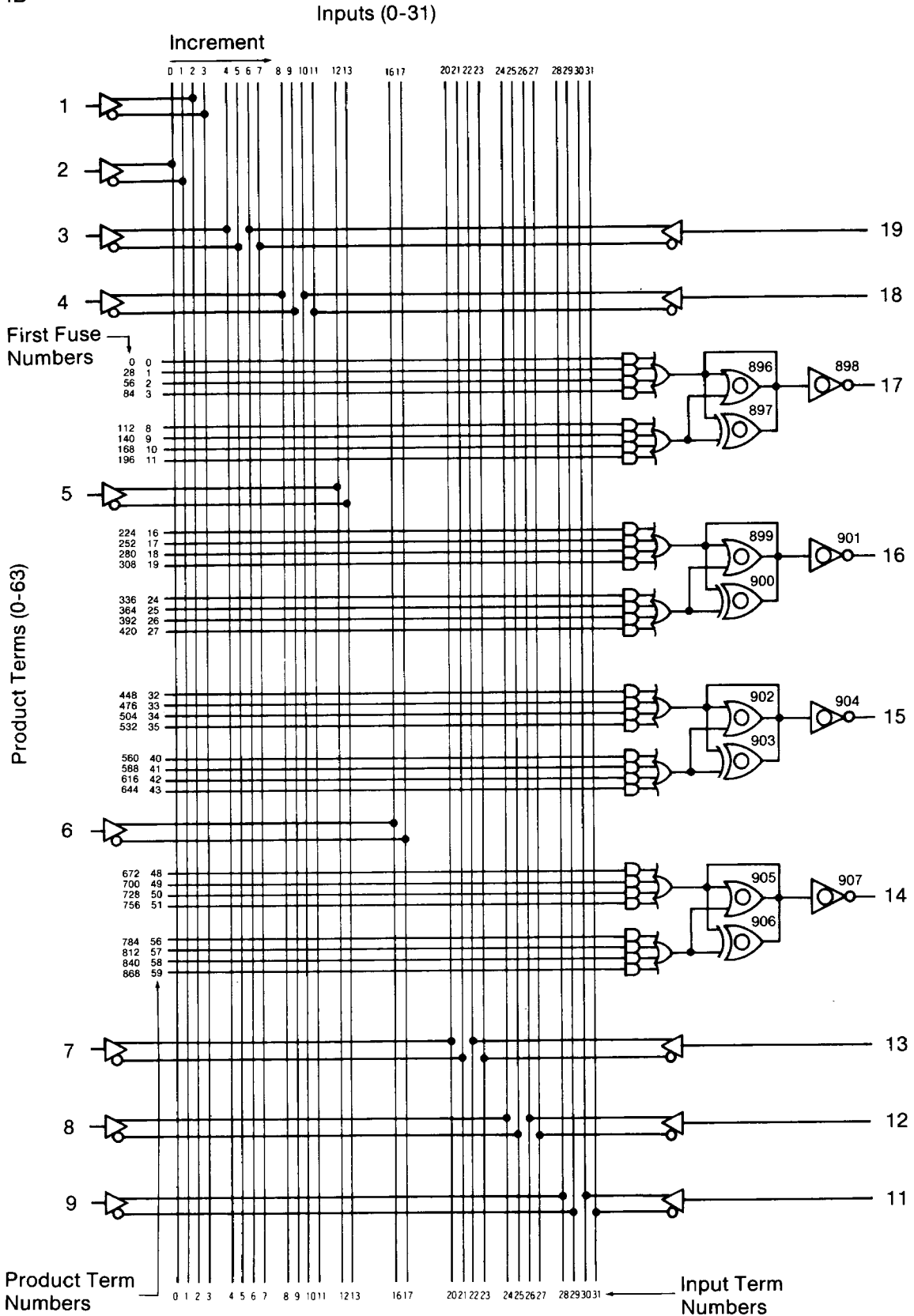

Logic Diagram
EPL16P2A
EPL16P2B

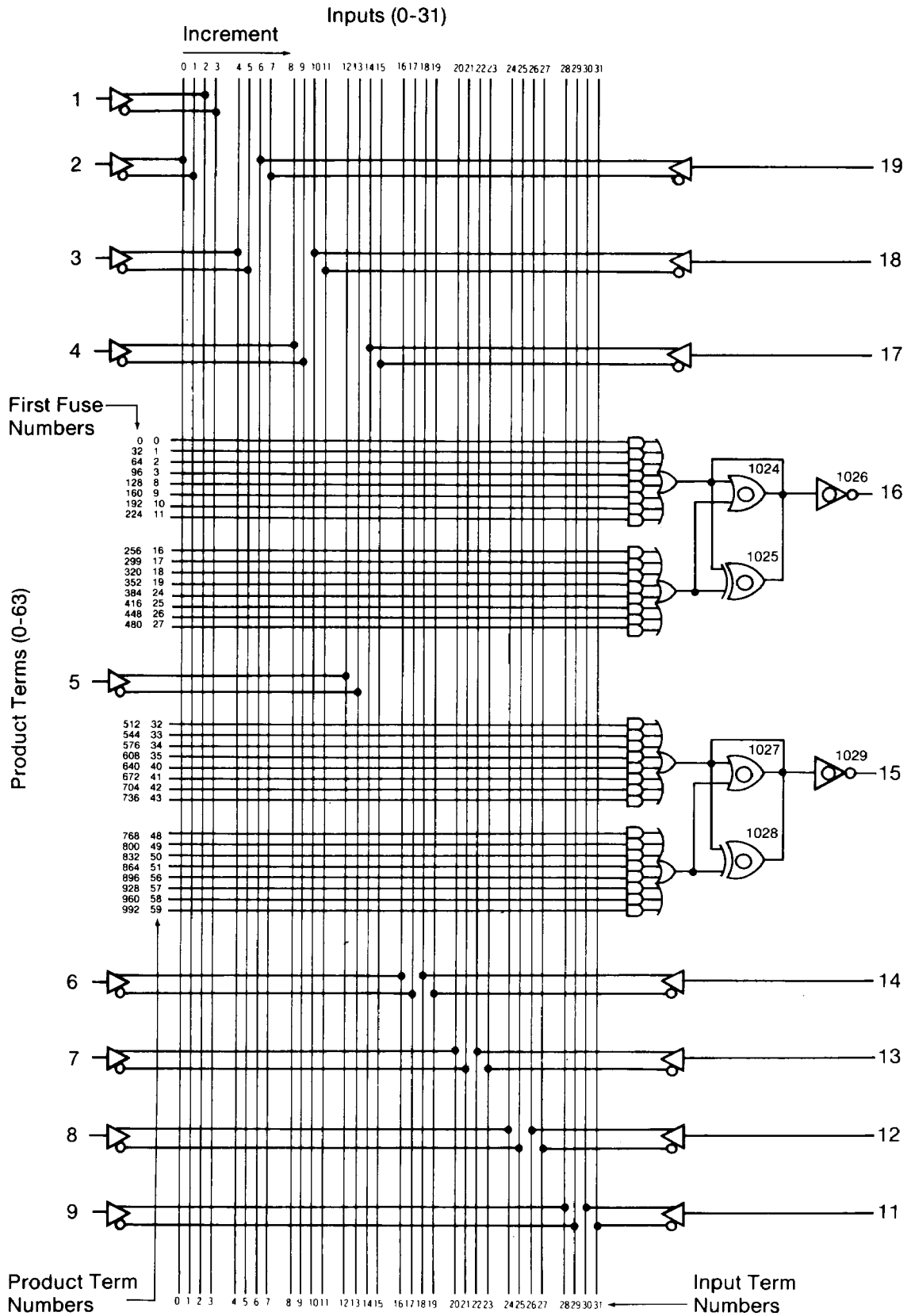

Logic Diagram
EPL16P8B

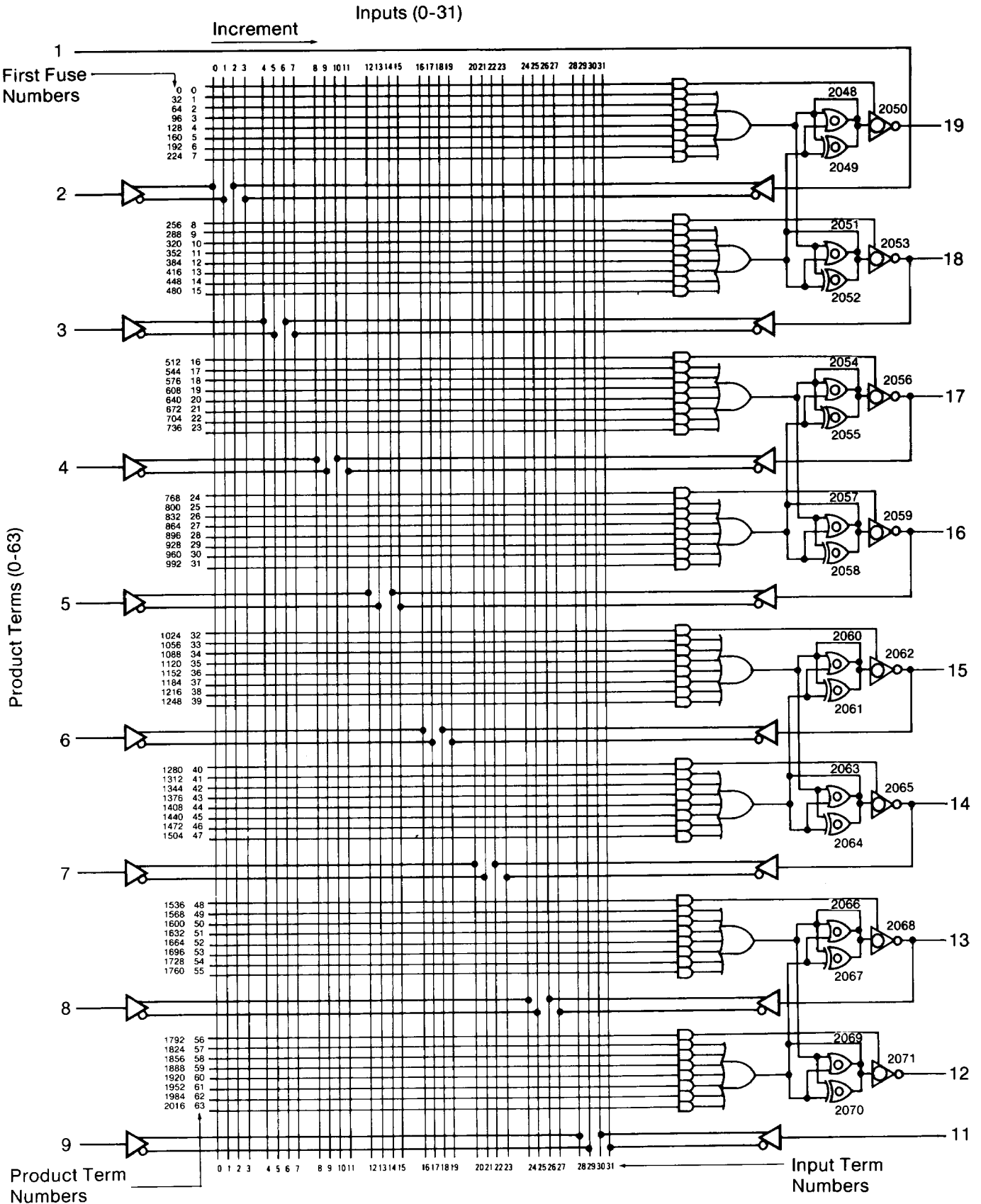

Logic Diagram
EPL16RP4B

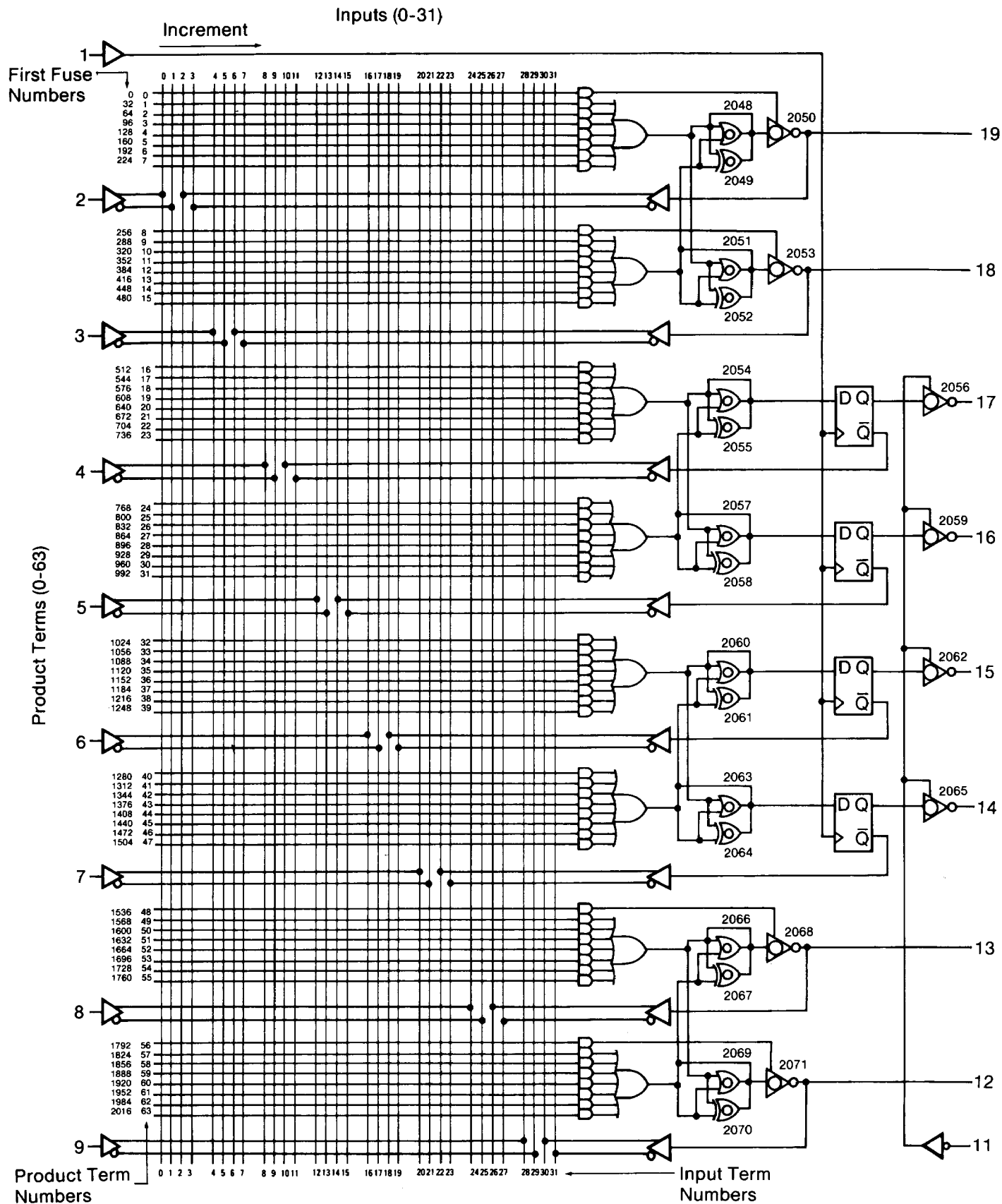

Logic Diagram
EPL16RP6B

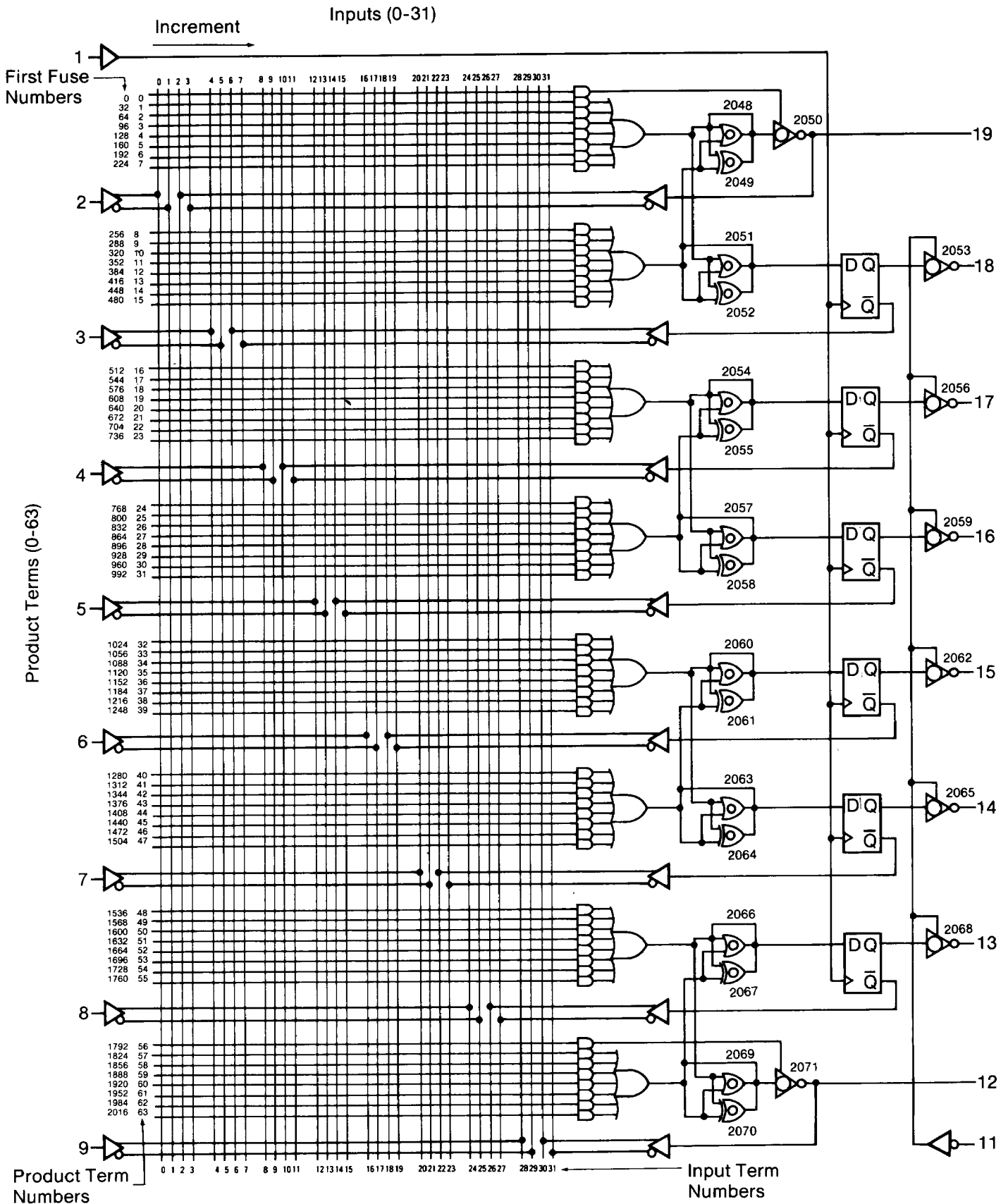

Logic Diagram
EPL16RP8B

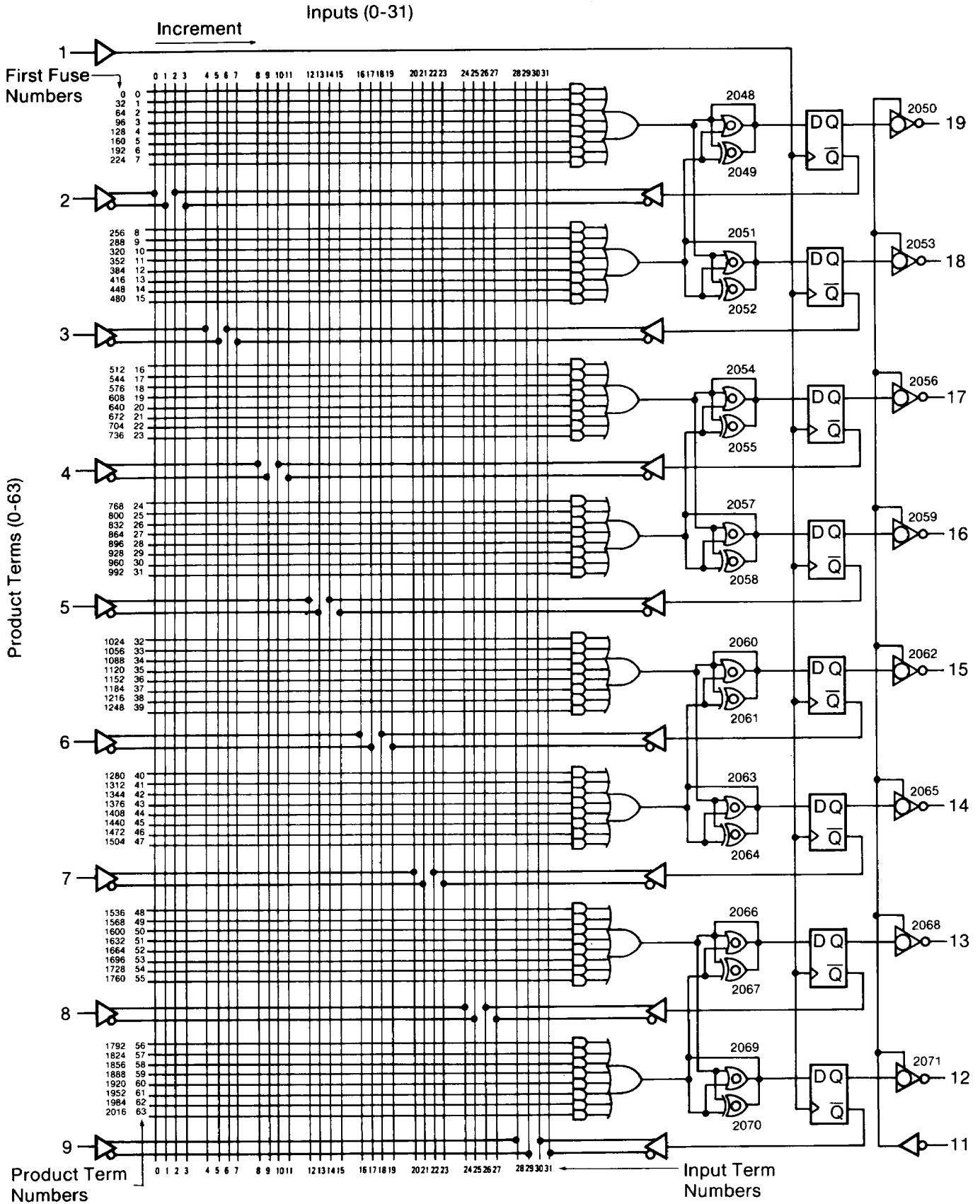

Cross Reference Guide EPL to PAL

EPL Group I	10P8	12P6	14P4	16P2
Small PAL	10H8	12H6	14P4	16H2
	10L8	12L6	14L4	16L2
	10P8	12P6	14H4	16P2
				16C1

EPL Group II	16P8	16RP8	16RP6	16RP4
Medium PAL	16H8	16R8	16R6	16R4
	16L8	16RP8	16RP6	16RP4
	16P8			

Packaging

20-Pin Plastic DIP Packaging 1-Shot (Unit: mm)

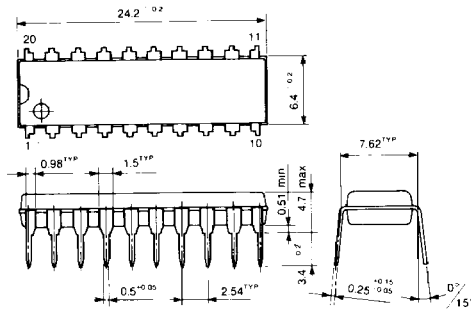

20-Pin Ceramic DIP Reprogrammable
(Glass Sealed with a quartz window) (Unit: mm)

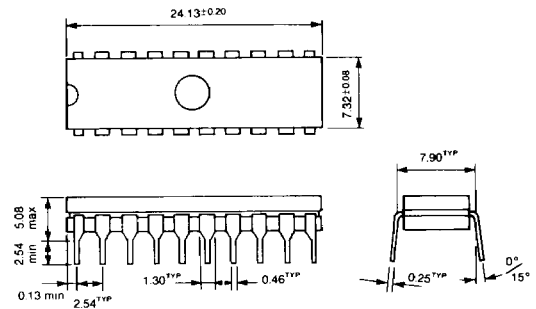

NOTES: EPL, EPLASM are trademarks of RICOH, Inc.
 PAL is a trademark of Monolithic Memories, Inc.
 MS-DOS is a trademark of Microsoft, Inc.
 CP/M and DEC VAX/VMS are trademarks of Digital Equipment Corp.
 UNIX is a trademark of AT&T.
 CUPL is a trademark of Assisted Technology, Inc.
 ABEL is a trademark of Data I/O Corp.