

REVISIONS			
LTR	DESCRIPTION	DATE (YR-MO-DA)	APPROVED
A	Add two vendors, CAGE 24355 and CAGE 17856. Add device type 02. Make changes to 1.2.1, 1.3, 1.4, and table I, figure 1, and figure 3. Editorial changes throughout.	89-11-09	M. A. Frye
B	Remove vendor, CAGE 24355 from device types 01 and 02. Add device type 03. Table I changes. Editorial changes throughout.	93-03-02	M. A. Frye
C	Update boilerplate to add class V. -rrp	00-09-07	R. Monnin
D	Update to current requirements. Editorial changes throughout. - drw	03-05-01	Raymond Monnin



REV																				
SHEET																				
REV																				
SHEET																				
REV STATUS	REV	D	D	D	D	D	D	D	D	D	D	D	D	D	D	D	D			
OF SHEETS	SHEET	1	2	3	4	5	6	7	8	9	10	11	12	13						
PMIC N/A	PREPARED BY Rick Officer		<b>DEFENSE SUPPLY CENTER COLUMBUS</b> <b>COLUMBUS, OHIO 43216</b> <a href="http://www.dsccl.dla.mil">http://www.dsccl.dla.mil</a>																	
<b>STANDARD MICROCIRCUIT DRAWING</b>  THIS DRAWING IS AVAILABLE FOR USE BY ALL DEPARTMENTS AND AGENCIES OF THE DEPARTMENT OF DEFENSE  AMSC N/A	CHECKED BY Charles E. Besore																			
	APPROVED BY Michael A. Frye																			
	DRAWING APPROVAL DATE 87-01-30																			
	REVISION LEVEL D	SIZE A	CAGE CODE <b>67268</b>	<b>5962-86716</b>																
		SHEET		1 OF 13																

1. SCOPE

1.1 Scope. This drawing documents two product assurance class levels consisting of high reliability (device classes Q and M) and space application (device class V). A choice of case outlines and lead finishes are available and are reflected in the Part or Identifying Number (PIN). When available, a choice of Radiation Hardness Assurance (RHA) levels are reflected in the PIN.

1.2 PIN. The PIN is as shown in the following examples.

For device classes M and Q:

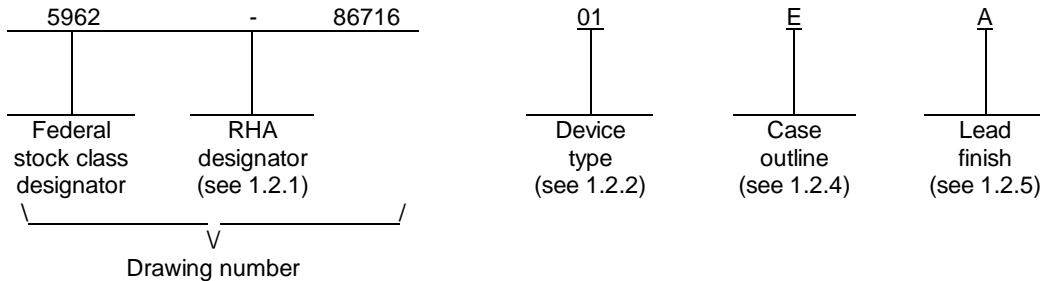

For device class V:

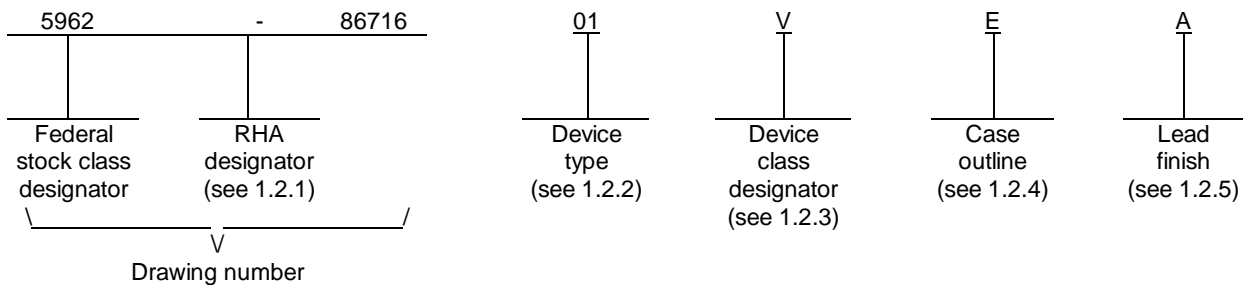

1.2.1 RHA designator. Device classes Q and V RHA marked devices meet the MIL-PRF-38535 specified RHA levels and are marked with the appropriate RHA designator. Device class M RHA marked devices meet the MIL-PRF-38535, appendix A specified RHA levels and are marked with the appropriate RHA designator. A dash (-) indicates a non-RHA device.

1.2.2 Device types. The device types identify the circuit function as follows:

<u>Device type</u>	<u>Generic number</u>	<u>Circuit function</u>
01	HI201HS	High speed quad SPST CMOS analog switch
02	DG271	High speed quad SPST CMOS analog switch
03	ADG201HST	High speed quad SPST CMOS analog switch

1.2.3 Device class designator. The device class designator is a single letter identifying the product assurance level as listed below. Since the device class designator has been added after the original issuance of this drawing, device classes M and Q designators will not be included in the PIN and will not be marked on the device.

<u>Device class</u>	<u>Device requirements documentation</u>
M	Vendor self-certification to the requirements for MIL-STD-883 compliant, non-JAN class level B microcircuits in accordance with MIL-PRF-38535, appendix A
Q or V	Certification and qualification to MIL-PRF-38535

<b>STANDARD MICROCIRCUIT DRAWING</b> DEFENSE SUPPLY CENTER COLUMBUS COLUMBUS, OHIO 43216-5000	SIZE <b>A</b>		<b>5962-86716</b>
		REVISION LEVEL <b>D</b>	SHEET <b>2</b>

1.2.4 Case outlines. The case outlines are as designated in MIL-STD-1835 and as follows:

<u>Outline letter</u>	<u>Descriptive designator</u>	<u>Terminals</u>	<u>Package style</u>
E	GDIP1-T16 or CDIP2-T16	16	Dual-in-line
2	CQCC1-N20	20	Square leadless chip carrier

1.2.5 Lead finish. The lead finish is as specified in MIL-PRF-38535 for device classes Q and V or MIL-PRF-38535, appendix A for device class M.

1.3 Absolute maximum ratings. 1/ 2/

Positive supply voltage (V+ to ground):	
Device type 01 .....	+18 V
Device types 02 and 03 .....	+25 V
Negative supply voltage (V- to ground):	
Device type 01 .....	-18 V
Device types 02 and 03 .....	-25 V
Digital input voltage (V <sub>IN</sub> ):	
Device types 01 and 03 .....	V- (-4 V) to V+ (+4 V) or 20 mA, whichever comes first
Device type 02 .....	V- (-2 V) to V+ (+2 V) or 20 mA, whichever comes first
Analog input voltage, one switch (V <sub>S</sub> ) .....	V- (-2 V) to V+ (+2 V) or 20 mA, whichever comes first
Maximum power dissipation (P <sub>D</sub> ):	
Device types 01 and 03 .....	750 mW <u>3/</u>
Device type 02 .....	900 mW <u>4/</u>
Maximum junction temperature (T <sub>J</sub> ) .....	+150°C
Lead temperature (soldering, 10 seconds) .....	+275°C
Thermal resistance, junction-to-case (θ <sub>JC</sub> ) .....	See MIL-STD-1835
Thermal resistance, junction-to-ambient (θ <sub>JA</sub> ) .....	76°C/W
Storage temperature range .....	-65°C to +150°C
Peak current, S or D (pulsed at 1 ms, 10 percent duty cycle max):	
Device type 01 .....	50 mA
Device type 02 .....	100 mA
Device type 03 .....	70 mA
Continuous current, any terminal (except S or D):	
Device type 01 .....	25 mA
Device types 02 and 03 .....	20 mA

1.4 Recommended operating conditions.

Positive supply voltage (V+) .....	+15 V dc
Negative supply voltage (V-) .....	-15 V dc
Minimum high level input voltage (V <sub>IH</sub> ):	
Device types 01 and 03 .....	2.4 V dc
Device type 02 .....	2.0 V dc
Maximum low level input voltage (V <sub>IL</sub> ) .....	0.8 V dc
Ambient operating temperature range (T <sub>A</sub> ) .....	-55°C to +125°C
Ground (GND) .....	0 V dc

1/ Stresses above the absolute maximum rating may cause permanent damage to the device. Extended operation at the maximum levels may degrade performance and affect reliability.

2/ Unless otherwise specified, all voltages are referenced to ground.

3/ Derate case E, 8 mW/°C above T<sub>A</sub> = +75°C. Derate case 2, 10 mW/°C above T<sub>A</sub> = +75°C.

4/ Derate case E, 12 mW/°C above T<sub>A</sub> = +75°C. Derate case 2, 10 mW/°C above T<sub>A</sub> = +75°C.

<b>STANDARD MICROCIRCUIT DRAWING</b> DEFENSE SUPPLY CENTER COLUMBUS COLUMBUS, OHIO 43216-5000	SIZE <b>A</b>		<b>5962-86716</b>
		REVISION LEVEL <b>D</b>	SHEET <b>3</b>

2. APPLICABLE DOCUMENTS

2.1 Government specification, standards, and handbooks. The following specification, standards, and handbooks form a part of this drawing to the extent specified herein. Unless otherwise specified, the issues of these documents are those listed in the issue of the Department of Defense Index of Specifications and Standards (DoDISS) and supplement thereto, cited in the solicitation.

SPECIFICATION

DEPARTMENT OF DEFENSE

MIL-PRF-38535 - Integrated Circuits, Manufacturing, General Specification for.

STANDARDS

DEPARTMENT OF DEFENSE

MIL-STD-883 - Test Method Standard Microcircuits.  
 MIL-STD-1835 - Interface Standard Electronic Component Case Outlines.

HANDBOOKS

DEPARTMENT OF DEFENSE

MIL-HDBK-103 - List of Standard Microcircuit Drawings.  
 MIL-HDBK-780 - Standard Microcircuit Drawings.

(Unless otherwise indicated, copies of the specification, standards, and handbooks are available from the Standardization Document Order Desk, 700 Robbins Avenue, Building 4D, Philadelphia, PA 19111-5094.)

2.2 Order of precedence. In the event of a conflict between the text of this drawing and the references cited herein, the text of this drawing takes precedence. Nothing in this document, however, supersedes applicable laws and regulations unless a specific exemption has been obtained.

3. REQUIREMENTS

3.1 Item requirements. The individual item requirements for device classes Q and V shall be in accordance with MIL-PRF-38535 and as specified herein or as modified in the device manufacturer's Quality Management (QM) plan. The modification in the QM plan shall not affect the form, fit, or function as described herein. The individual item requirements for device class M shall be in accordance with MIL-PRF-38535, appendix A for non-JAN class level B devices and as specified herein.

3.2 Design, construction, and physical dimensions. The design, construction, and physical dimensions shall be as specified in MIL-PRF-38535 and herein for device classes Q and V or MIL-PRF-38535, appendix A and herein for device class M.

3.2.1 Case outlines. The case outlines shall be in accordance with 1.2.4 herein.

3.2.2 Terminal connections. The terminal connections shall be as specified on figure 1.

3.2.3 Functional diagram. The functional diagram shall be as specified on figure 2.

3.3 Electrical performance characteristics and postirradiation parameter limits. Unless otherwise specified herein, the electrical performance characteristics and postirradiation parameter limits are as specified in table I and shall apply over the full ambient operating temperature range.

3.4 Electrical test requirements. The electrical test requirements shall be the subgroups specified in table IIA. The electrical tests for each subgroup are defined in table I.

<b>STANDARD                  MICROCIRCUIT DRAWING</b> DEFENSE SUPPLY CENTER COLUMBUS COLUMBUS, OHIO 43216-5000	SIZE <b>A</b>		<b>5962-86716</b>
		REVISION LEVEL <b>D</b>	SHEET <b>4</b>

TABLE I. Electrical performance characteristics.

Test	Symbol	Conditions -55°C ≤ T <sub>A</sub> ≤ +125°C V <sub>+</sub> = +15 V dc, V <sub>-</sub> = -15 V dc unless otherwise specified	Group A subgroups	Device type	Limits <u>1/</u>		Unit
					Min	Max	
Analog signal range	V <sub>S</sub>	T <sub>A</sub> = +25°C <u>2/</u>	4	All		±15	V
ON resistance	R <sub>DS(ON)</sub>	V <sub>S</sub> = ±10 V, I <sub>D</sub> = 1 mA, V <sub>IN</sub> = 0.8 V	1	All		50	Ω
			2, 3			75	
Source OFF leakage current	I <sub>S(OFF)</sub>	V <sub>S</sub> = ±14 V, V <sub>D</sub> = ±14 V, V <sub>IN</sub> = 2.4 V	1	01		±10	nA
			2, 3			±100	
		V <sub>D</sub> = ±14 V, V <sub>S</sub> = ±14 V, V <sub>IN</sub> = 2.4 V	1	02, 03		±1	
			2, 3		02	±100	
		03	±60				
Drain OFF leakage current	I <sub>D(OFF)</sub>	V <sub>S</sub> = ±14 V, V <sub>D</sub> = ±14 V, V <sub>IN</sub> = 2.4 V	1	01		±10	nA
			2, 3			±100	
		V <sub>D</sub> = ±14 V, V <sub>S</sub> = ±14 V, V <sub>IN</sub> = 2.4 V	1	02, 03		±1	
			2, 3		02	±100	
		03	±60				
Channel ON leakage current	I <sub>D(ON)</sub>	V <sub>D</sub> = V <sub>S</sub> = ±14 V, V <sub>IN</sub> = 0.8 V	1	01		±10	nA
			2, 3			±100	
			1	02, 03		±1	
			2, 3		02	±100	
		03	±60				
Low level input voltage <u>3/</u>	V <sub>IL</sub>		7, 8	All		0.8	V
High level input voltage <u>3/</u>	V <sub>IH</sub>		7, 8	01, 03	2.4		V
				02	2.0		
Input leakage current (low)	I <sub>IL</sub>	V <sub>IN</sub> under test = 0.8 V, All other V <sub>IN</sub> = 4.0 V	1, 2, 3	01		±500	μA
		V <sub>IN</sub> under test = 0 V, All other V <sub>IN</sub> = 2.0 V	1	02		±1	
			2, 3			±10	
V <sub>IN</sub> under test = 1.0 V, All other V <sub>IN</sub> = 16.5 V, V <sub>S</sub> = ±17 V	1, 2, 3	03		±1			

See footnotes at end of table.

<b>STANDARD MICROCIRCUIT DRAWING</b> DEFENSE SUPPLY CENTER COLUMBUS COLUMBUS, OHIO 43216-5000	SIZE <b>A</b>		<b>5962-86716</b>
		REVISION LEVEL <b>D</b>	SHEET <b>5</b>

TABLE I. Electrical performance characteristics – Continued.

Test	Symbol	Conditions -55°C ≤ T <sub>A</sub> ≤ +125°C V <sub>+</sub> = +15 V dc, V <sub>-</sub> = -15 V dc unless otherwise specified	Group A subgroups	Device type	Limits <u>1/</u>		Unit
					Min	Max	
Input leakage current (high)	I <sub>IH</sub>	V <sub>IN</sub> under test = 4.0 V, All other V <sub>IN</sub> = 0.8 V	1, 2, 3	01		±40	μA
		V <sub>IN</sub> under test = 2.0 V, All other V <sub>IN</sub> = 0 V	1	02		±1	
			2, 3			±10	
V <sub>IN</sub> under test = 16.5 V, All other V <sub>IN</sub> = 1.0 V, V <sub>S</sub> = ±17 V	1, 2, 3	03		±1			
Positive supply current	I <sub>+</sub>	V <sub>IN</sub> = 2.4 V or V <sub>IN</sub> = 0.8 V for all switches	1, 2, 3	01		10	mA
		V <sub>IN</sub> = 0 V or V <sub>IN</sub> = 2.0 V for all switches	1	02		10	
			2, 3			11	
V <sub>IN</sub> = 3.0 V or V <sub>IN</sub> = 0.8 V for all switches	1, 2, 3	03		10			
Negative supply current	I <sub>-</sub>	V <sub>IN</sub> = 2.4 V or V <sub>IN</sub> = 0.8 V for all switches	1, 2, 3	01		-6	mA
		V <sub>IN</sub> = 0 V or V <sub>IN</sub> = 2.0 V for all switches	1	02		-6	
			2, 3			-10	
V <sub>IN</sub> = 2.4 V or V <sub>IN</sub> = 0.8 V for all switches	1, 2, 3	03		-6			
Switch on time	t <sub>ON</sub>	R <sub>L</sub> = 1 kΩ, C <sub>L</sub> = 35 pF, V <sub>S</sub> = ±10 V, V <sub>IH</sub> = +3 V, V <sub>IL</sub> = 0 V, See figure 3	9	01		50	ns
			10, 11			100	
		R <sub>L</sub> = 1 kΩ, C <sub>L</sub> = 35 pF, V <sub>S</sub> = ±10 V, V <sub>IH</sub> = +5 V, V <sub>IL</sub> = 0 V, See figure 3	9	02		65	
			10, 11			80	
R <sub>L</sub> = 1 kΩ, C <sub>L</sub> = 35 pF, V <sub>S</sub> = ±10 V, V <sub>IH</sub> = +3 V, V <sub>IL</sub> = 0 V, See figure 3	9, 10, 11	03		50			
Switch off time	t <sub>OFF</sub>	R <sub>L</sub> = 1 kΩ, C <sub>L</sub> = 35 pF, V <sub>S</sub> = ±10 V, V <sub>IH</sub> = +3 V, V <sub>IL</sub> = 0 V, See figure 3	9	01		50	ns
			10, 11			100	
		R <sub>L</sub> = 1 kΩ, C <sub>L</sub> = 35 pF, V <sub>S</sub> = ±10 V, V <sub>IH</sub> = +5 V, V <sub>IL</sub> = 0 V, See figure 3	9	02		65	
			10, 11			80	
R <sub>L</sub> = 1 kΩ, C <sub>L</sub> = 35 pF, V <sub>S</sub> = ±10 V, V <sub>IH</sub> = +3 V, V <sub>IL</sub> = 0 V, See figure 3	9, 10, 11	03		50			

See footnotes at end of table.

<b>STANDARD MICROCIRCUIT DRAWING</b> DEFENSE SUPPLY CENTER COLUMBUS COLUMBUS, OHIO 43216-5000	SIZE <b>A</b>		<b>5962-86716</b>
		REVISION LEVEL <b>D</b>	SHEET <b>6</b>

TABLE I. Electrical performance characteristics – Continued.

Test	Symbol	Conditions -55°C ≤ T <sub>A</sub> ≤ +125°C V <sub>+</sub> = +15 V dc, V <sub>-</sub> = -15 V dc unless otherwise specified	Group A subgroups	Device type	Limits <sup>1/</sup>		Unit
					Min	Max	
Capacitance address	C <sub>A</sub>	GND = 0 V, V <sub>IL</sub> = 0 V, f = 1 MHz, T <sub>A</sub> = +25°C <sup>4/</sup>	4	All		15	pF
Capacitance input switch	C <sub>IS</sub>	GND = 0 V, V <sub>IH</sub> = 5 V, f = 1 MHz, T <sub>A</sub> = +25°C <sup>4/</sup>	4	All		15	pF
Capacitance output switch	C <sub>OS</sub>	GND = 0 V, V <sub>IH</sub> = 5 V, f = 1 MHz, T <sub>A</sub> = +25°C <sup>4/</sup>	4	All		20	pF
Off isolation	V <sub>ISO</sub>	V <sub>GEN</sub> = 1 V <sub>P-P</sub> , f = 100 kHz, T <sub>A</sub> = +25°C <sup>2/</sup>	4	All	60		dB
Crosstalk between channels	V <sub>CT</sub>	V <sub>GEN</sub> = 1 V <sub>P-P</sub> , f = 100 kHz, T <sub>A</sub> = +25°C <sup>2/</sup>	4	All	60		dB
Charge transfer error	V <sub>CTE</sub>	T <sub>A</sub> = +25°C <sup>2/</sup>	4	All		±10	mV

<sup>1/</sup> The limiting terms "min" (minimum) and "max" (maximum) shall be considered to apply to magnitudes only. Negative current shall be defined as conventional current flow out of a device terminal.

<sup>2/</sup> These parameters may not be tested, but shall be guaranteed to the limits specified in table I herein.

<sup>3/</sup> Test not required if applied as a forcing function.

<sup>4/</sup> Subgroup 4 (C<sub>A</sub>, C<sub>IS</sub>, and C<sub>OS</sub> measurements) shall be measured only for the initial test and after process or design changes which may affect capacitance.

3.5 Marking. The part shall be marked with the PIN listed in 1.2 herein. In addition, the manufacturer's PIN may also be marked as listed in MIL-HDBK-103. For packages where marking of the entire SMD PIN number is not feasible due to space limitations, the manufacturer has the option of not marking the "5962-" on the device. For RHA product using this option, the RHA designator shall still be marked. Marking for device classes Q and V shall be in accordance with MIL-PRF-38535. Marking for device class M shall be in accordance with MIL-PRF-38535, appendix A.

3.5.1 Certification/compliance mark. The certification mark for device classes Q and V shall be a "QML" or "Q" as required in MIL-PRF-38535. The compliance mark for device class M shall be a "C" as required in MIL-PRF-38535, appendix A.

3.6 Certificate of compliance. For device classes Q and V, a certificate of compliance shall be required from a QML-38535 listed manufacturer in order to supply to the requirements of this drawing (see 6.6.1 herein). For device class M, a certificate of compliance shall be required from a manufacturer in order to be listed as an approved source of supply in MIL-HDBK-103 (see 6.6.2 herein). The certificate of compliance submitted to DSCC-VA prior to listing as an approved source of supply for this drawing shall affirm that the manufacturer's product meets, for device classes Q and V, the requirements of MIL-PRF-38535 and herein or for device class M, the requirements of MIL-PRF-38535, appendix A and herein.

3.7 Certificate of conformance. A certificate of conformance as required for device classes Q and V in MIL-PRF-38535 or for device class M in MIL-PRF-38535, appendix A shall be provided with each lot of microcircuits delivered to this drawing.

3.8 Notification of change for device class M. For device class M, notification to DSCC-VA of change of product (see 6.2 herein) involving devices acquired to this drawing is required for any change as defined in MIL-PRF-38535, appendix A.

3.9 Verification and review for device class M. For device class M, DSCC, DSCC's agent, and the acquiring activity retain the option to review the manufacturer's facility and applicable required documentation. Offshore documentation shall be made available onshore at the option of the reviewer.

3.10 Microcircuit group assignment for device class M. Device class M devices covered by this drawing shall be in microcircuit group number 82 (see MIL-PRF-38535, appendix A).

<b>STANDARD MICROCIRCUIT DRAWING</b> DEFENSE SUPPLY CENTER COLUMBUS COLUMBUS, OHIO 43216-5000	SIZE <b>A</b>		<b>5962-86716</b>
		REVISION LEVEL <b>D</b>	SHEET <b>7</b>

Device types	01, 02, and 03	
Case outlines	E	2
Terminal number	Terminal symbol	
1	IN <sub>1</sub>	NC
2	D <sub>1</sub>	IN <sub>1</sub>
3	S <sub>1</sub>	D <sub>1</sub>
4	V-	S <sub>1</sub>
5	GND	V-
6	S <sub>4</sub>	NC
7	D <sub>4</sub>	GND
8	IN <sub>4</sub>	S <sub>4</sub>
9	IN <sub>3</sub>	D <sub>4</sub>
10	D <sub>3</sub>	IN <sub>4</sub>
11	S <sub>3</sub>	NC
12	NC	IN <sub>3</sub>
13	V+	D <sub>3</sub>
14	S <sub>2</sub>	S <sub>3</sub>
15	D <sub>2</sub>	NC
16	IN <sub>2</sub>	NC
17	----	V+
18	----	S <sub>2</sub>
19	----	D <sub>2</sub>
20	----	IN <sub>2</sub>

NOTES:

1. NC = No connection
2. The source and drain are interchangeable and have been arbitrarily established.

FIGURE 1. Terminal connections.

<b>STANDARD MICROCIRCUIT DRAWING</b> DEFENSE SUPPLY CENTER COLUMBUS COLUMBUS, OHIO 43216-5000	SIZE <b>A</b>		<b>5962-86716</b>
		REVISION LEVEL <b>D</b>	SHEET <b>8</b>



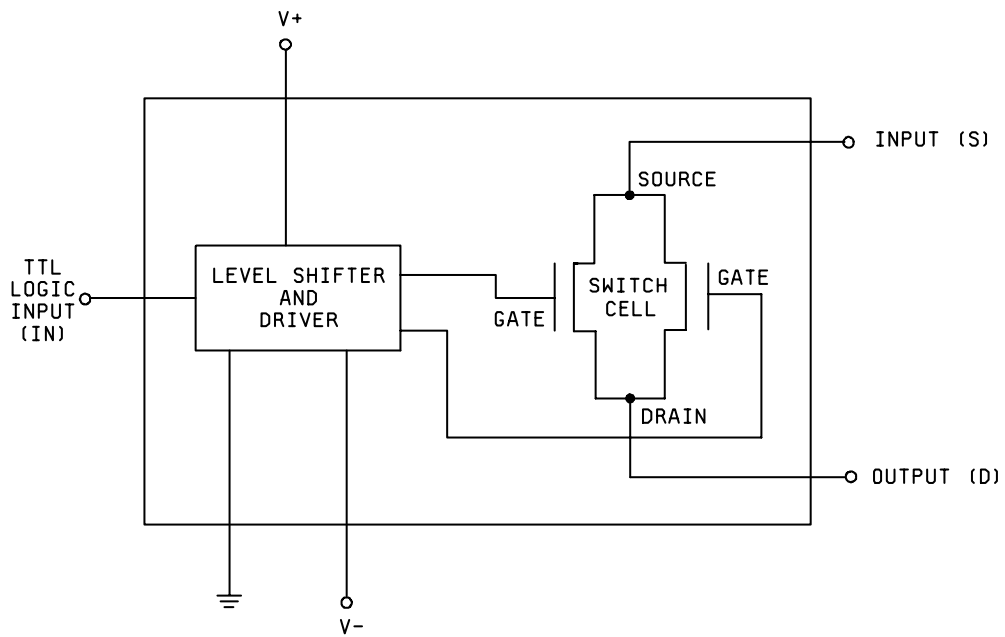
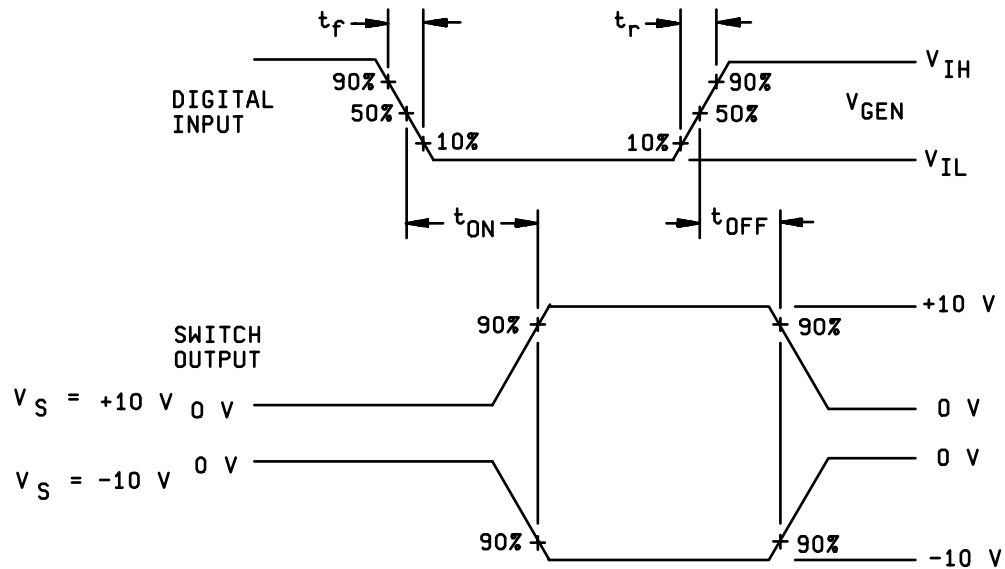

FIGURE 2. Functional diagram.

<b>STANDARD MICROCIRCUIT DRAWING</b> DEFENSE SUPPLY CENTER COLUMBUS COLUMBUS, OHIO 43216-5000	SIZE <b>A</b>		<b>5962-86716</b>
		REVISION LEVEL <b>D</b>	SHEET <b>9</b>



NOTE: Rise time and fall time  $\leq 20\text{ ns}$ .

FIGURE 3. Test circuit and switching waveforms.

<b>STANDARD MICROCIRCUIT DRAWING</b> DEFENSE SUPPLY CENTER COLUMBUS COLUMBUS, OHIO 43216-5000	SIZE <b>A</b>		<b>5962-86716</b>
		REVISION LEVEL <b>D</b>	SHEET <b>10</b>

4. QUALITY ASSURANCE PROVISIONS

4.1 Sampling and inspection. For device classes Q and V, sampling and inspection procedures shall be in accordance with MIL-PRF-38535 or as modified in the device manufacturer's Quality Management (QM) plan. The modification in the QM plan shall not affect the form, fit, or function as described herein. For device class M, sampling and inspection procedures shall be in accordance with MIL-PRF-38535, appendix A.

4.2 Screening. For device classes Q and V, screening shall be in accordance with MIL-PRF-38535, and shall be conducted on all devices prior to qualification and technology conformance inspection. For device class M, screening shall be in accordance with method 5004 of MIL-STD-883, and shall be conducted on all devices prior to quality conformance inspection.

4.2.1 Additional criteria for device class M.

- a. Burn-in test, method 1015 of MIL-STD-883.
  - (1) Test condition A, B, C or D. The test circuit shall be maintained by the manufacturer under document revision level control and shall be made available to the preparing or acquiring activity upon request. The test circuit shall specify the inputs, outputs, biases, and power dissipation, as applicable, in accordance with the intent specified in test method 1015.
  - (2)  $T_A = +125^{\circ}\text{C}$ , minimum.
- b. Interim and final electrical test parameters shall be as specified in table IIA herein.

4.2.2 Additional criteria for device classes Q and V.

- a. The burn-in test duration, test condition and test temperature, or approved alternatives shall be as specified in the device manufacturer's QM plan in accordance with MIL-PRF-38535. The burn-in test circuit shall be maintained under document revision level control of the device manufacturer's Technology Review Board (TRB) in accordance with MIL-PRF-38535 and shall be made available to the acquiring or preparing activity upon request. The test circuit shall specify the inputs, outputs, biases, and power dissipation, as applicable, in accordance with the intent specified in test method 1015 of MIL-STD-883.
- b. Interim and final electrical test parameters shall be as specified in table IIA herein.
- c. Additional screening for device class V beyond the requirements of device class Q shall be as specified in MIL-PRF-38535, appendix B.

4.3 Qualification inspection for device classes Q and V. Qualification inspection for device classes Q and V shall be in accordance with MIL-PRF-38535. Inspections to be performed shall be those specified in MIL-PRF-38535 and herein for groups A, B, C, D, and E inspections (see 4.4.1 through 4.4.4).

4.4 Conformance inspection. Technology conformance inspection for classes Q and V shall be in accordance with MIL-PRF-38535 including groups A, B, C, D, and E inspections and as specified herein except where option 2 of MIL-PRF-38535 permits alternate in-line control testing. Quality conformance inspection for device class M shall be in accordance with MIL-PRF-38535, appendix A and as specified herein. Inspections to be performed for device class M shall be those specified in method 5005 of MIL-STD-883 and herein for groups A, B, C, D, and E inspections (see 4.4.1 through 4.4.4).

4.4.1 Group A inspection.

- a. Tests shall be as specified in table IIA herein.
- b. Subgroups 5 and 6 in table I, method 5005 of MIL-STD-883 shall be omitted.

<b>STANDARD MICROCIRCUIT DRAWING</b> DEFENSE SUPPLY CENTER COLUMBUS COLUMBUS, OHIO 43216-5000	SIZE <b>A</b>		<b>5962-86716</b>
		REVISION LEVEL D	SHEET <b>11</b>

TABLE IIA. Electrical test requirements.

Test requirements	Subgroups (in accordance with MIL-STD-883, method 5005, table I)	Subgroups (in accordance with MIL-PRF-38535, table III)	
	Device class M	Device class Q	Device class V
Interim electrical parameters (see 4.2)	1	1	1
Final electrical parameters (see 4.2)	1,2,3,9,10,11 <u>1/</u>	1,2,3,9, <u>1/</u> 10, 11	1,2,3,4, <u>1/ 2/</u> 7,8,9,10,11
Group A test requirements (see 4.4)	1,2,3,4,7,8,9,10,11	1,2,3,4,7, 8,9,10,11	1,2,3,4,7, 8,9,10,11
Group C end-point electrical parameters (see 4.4)	1	1	1 <u>2/</u>
Group D end-point electrical parameters (see 4.4)	1	1	1
Group E end-point electrical parameters (see 4.4)	----	----	----

1/ PDA applies to subgroup 1. Exclude delta from PDA

2/ See table IIB for delta measurement parameters.

Table IIB. 240 hour burn-in and group C end-point electrical parameters.

Parameter	Device type	Burn-in limit	Life test limit	Delta
R <sub>DS(ON)</sub>	03	50 Ω	65 Ω	±15 Ω
I <sub>D(OFF)</sub>	03	±1 nA	±1 nA	±1 nA
I <sub>S(ON)</sub> + I <sub>D(ON)</sub>	03	±1 nA	±1 nA	±1 nA

4.4.2 Group C inspection. The group C inspection end-point electrical parameters shall be as specified in table IIA herein.

4.4.2.1 Additional criteria for device class M. Steady-state life test conditions, method 1005 of MIL-STD-883:

- a. Test condition A, B, C or D. The test circuit shall be maintained by the manufacturer under document revision level control and shall be made available to the preparing or acquiring activity upon request. The test circuit shall specify the inputs, outputs, biases, and power dissipation, as applicable, in accordance with the intent specified in test method 1005 of MIL-STD-883.
- b. T<sub>A</sub> = +125°C, minimum.
- c. Test duration: 1,000 hours, except as permitted by method 1005 of MIL-STD-883.

<b>STANDARD MICROCIRCUIT DRAWING</b> DEFENSE SUPPLY CENTER COLUMBUS COLUMBUS, OHIO 43216-5000	SIZE <b>A</b>		<b>5962-86716</b>
		REVISION LEVEL D	SHEET <b>12</b>

4.4.2.2 Additional criteria for device classes Q and V. The steady-state life test duration, test condition and test temperature, or approved alternatives shall be as specified in the device manufacturer's QM plan in accordance with MIL-PRF-38535. The test circuit shall be maintained under document revision level control by the device manufacturer's TRB in accordance with MIL-PRF-38535 and shall be made available to the acquiring or preparing activity upon request. The test circuit shall specify the inputs, outputs, biases, and power dissipation, as applicable, in accordance with the intent specified in test method 1005 of MIL-STD-883.

4.4.3 Group D inspection. The group D inspection end-point electrical parameters shall be as specified in table IIA herein.

4.4.4 Group E inspection. Group E inspection is required only for parts intended to be marked as radiation hardness assured (see 3.5 herein).

- a. End-point electrical parameters shall be as specified in table IIA herein.
- b. For device classes Q and V, the devices or test vehicle shall be subjected to radiation hardness assured tests as specified in MIL-PRF-38535 for the RHA level being tested. For device class M, the devices shall be subjected to radiation hardness assured tests as specified in MIL-PRF-38535, appendix A for the RHA level being tested. All device classes must meet the postirradiation end-point electrical parameter limits as defined in table I at  $T_A = +25^{\circ}\text{C} \pm 5^{\circ}\text{C}$ , after exposure, to the subgroups specified in table IIA herein.
- c. When specified in the purchase order or contract, a copy of the RHA delta limits shall be supplied.

## 5. PACKAGING

5.1 Packaging requirements. The requirements for packaging shall be in accordance with MIL-PRF-38535 for device classes Q and V or MIL-PRF-38535, appendix A for device class M.

## 6. NOTES

6.1 Intended use. Microcircuits conforming to this drawing are intended for use for Government microcircuit applications (original equipment), design applications, and logistics purposes.

6.1.1 Replaceability. Microcircuits covered by this drawing will replace the same generic device covered by a contractor-prepared specification or drawing.

6.2 Configuration control of SMD's. All proposed changes to existing SMD's will be coordinated with the users of record for the individual documents. This coordination will be accomplished using DD Form 1692, Engineering Change Proposal.

6.3 Record of users. Military and industrial users should inform Defense Supply Center Columbus when a system application requires configuration control and which SMD's are applicable to that system. DSCC will maintain a record of users and this list will be used for coordination and distribution of changes to the drawings. Users of drawings covering microelectronic devices (FSC 5962) should contact DSCC-VA, telephone (614) 692-0525.

6.4 Comments. Comments on this drawing should be directed to DSCC-VA, Columbus, Ohio 43216-5000, or telephone (614) 692-0547.

6.5 Abbreviations, symbols, and definitions. The abbreviations, symbols, and definitions used herein are defined in MIL-PRF-38535 and MIL-HDBK-1331.

6.6 Sources of supply.

6.6.1 Sources of supply for device classes Q and V. Sources of supply for device classes Q and V are listed in QML-38535. The vendors listed in QML-38535 have submitted a certificate of compliance (see 3.6 herein) to DSCC-VA and have agreed to this drawing.

6.6.2 Approved sources of supply for device class M. Approved sources of supply for class M are listed in MIL-HDBK-103. The vendors listed in MIL-HDBK-103 have agreed to this drawing and a certificate of compliance (see 3.6 herein) has been submitted to and accepted by DSCC-VA.

<b>STANDARD MICROCIRCUIT DRAWING</b> DEFENSE SUPPLY CENTER COLUMBUS COLUMBUS, OHIO 43216-5000	SIZE <b>A</b>		<b>5962-86716</b>
		REVISION LEVEL <b>D</b>	SHEET <b>13</b>

STANDARD MICROCIRCUIT DRAWING BULLETIN

DATE: 03-05-01

Approved sources of supply for SMD 5962-86716 are listed below for immediate acquisition information only and shall be added to MIL-HDBK-103 and QML-38535 during the next revision. MIL-HDBK-103 and QML-38535 will be revised to include the addition or deletion of sources. The vendors listed below have agreed to this drawing and a certificate of compliance has been submitted to and accepted by DSCC-VA. This bulletin is superseded by the next dated revision of MIL-HDBK-103 and QML-38535.

Standard microcircuit drawing PIN <u>1/</u>	Vendor CAGE number	Vendor similar PIN <u>2/</u>
5962-86716012A	34371	HI4-201HS/883
5962-86716012A	17856	DG201HSAZ/883
5962-8671601EA	34371	HI1-201HS/833
5962-8671601EA	17856	DG201HSAK/883
5962-86716022A	17856	DG271AZ/883
5962-8671602EA	17856	DG271AK/883
5962-86716032A	24355	ADG201HSTE/883B
5962-8671603EA	24355	ADG201HSTQ/883B
5962-8671603VEA	<u>3/</u>	ADG201HSTQ/QMLV

- 1/ The lead finish shown for each PIN representing a hermetic package is the most readily available from the manufacturer listed for that part. If the desired lead finish is not listed contact the vendor to determine its availability.
- 2/ Caution. Do not use this number for item acquisition. Items acquired to this number may not satisfy the performance requirements of this drawing.
- 3/ Not available from an approved source.

STANDARD MICROCIRCUIT DRAWING BULLETIN – Continued

<u>Vendor CAGE number</u>	<u>Vendor name and address</u>
34371	Intersil Corporation P.O. Box 883 Melbourne, FL 32902-0883
17856	Siliconix Inc 2201 Laurelwood Road Santa Clara, CA 95054-1516
24355	Analog Devices RT 1 Industrial Park PO Box 9106 Norwood, MA 02062 Point of contact: 1500 Space Park Drive P.O. Box 58020 Santa Clara, CA 95052-8020

The information contained herein is disseminated for convenience only and the Government assumes no liability whatsoever for any inaccuracies in the information bulletin.