



Intelligent Low-Flow Duct Smoke Detectors



Intelligent Models Available

- DH200PL (non-relay)
- DH200RPL (with relay)

Product Overview

Air velocity rating from 100 to 4000 feet per minute (0.5 to 20.32 m/sec.)

Patented telescopic sampling tube

Easily accessible code wheels

Outside mounting tabs

Easy and quick mounting to round or rectangular ducts from 1'-12' (0.3-3.7 meters) wide

Easy to clean

UL recognized field-replaceable power and sensor boards

Transparent cover for convenient visual inspection

UL 268A listed

3-year warranty

DH200PL (non-relay)

Has outputs for remote LED display, remote test

Incorporates zener diodes to conserve power for communications to other devices

Requires com line power only

DH200RPL (with relay)

Powered outputs for remote LED, and remote test and sounder

Two form "C" auxiliary contacts

Can be configured as a relay version or jumpered to mimic a non-relay version

Patented cover tamper trouble signal

Requires both com line power and one of the following; 24VAC/DC or

120/220VAC for operation



The System Sensor Innovair™ DH200 Low-Flow Series photoelectric air duct smoke detectors are capable of sensing smoke in air velocities from 100 to 4,000 feet per minute (0.5 to 20.32 m/sec).

This Innovair features low-flow technology that enables duct smoke detection throughout a broad range of airflow environments. Many difficult to solve HVAC applications occur in low airflow duct applications where reliable smoke detection is critical. Innovair low-flow technology can detect smoke at air speed velocities of 100 feet per minute or greater, while continuing the same reliable performance to 4,000 feet per minute.

The DH200 Series Detector samples air currents passing through a duct and gives dependable performance for shutdown of fans, blowers, and air conditioning systems, preventing the spread of toxic smoke and fire gases through the protected area.

These intelligent sensors communicate and are continuously monitored through the communication line. Detector sensitivity changes caused by dirt, temperature, or humidity are reported to the panel, allowing compensation algorithms to maintain the sensor's set sensitivity. An advance indication at the panel specifies the sensor address, allowing for selected maintenance to be performed as needed.

Remote alarm annunciation can be accomplished by using the RA400Z Remote Annunciator or the RTS451 or RTS451KEY Remote Test Station. Both these devices allow testing of the detector from a remote location.

The Innovair family is designed for simplified installation and easy maintenance. The modular construction allows for easy cleaning and uncomplicated field replacement of the UL recognized power and sensor boards.

WARNING: Duct smoke detectors have specific limitations.

DUCT SMOKE DETECTORS ARE:

- NOT a substitute for an open area smoke detector,
- NOT a substitute for early warning detection, and
- NOT a replacement for a building's regular fire detection system.

Refer to NFPA 72 and 90A for additional duct smoke detector application information.



Architect/Engineer Specifications

The duct smoke detector shall be a System Sensor Model DH200PL or DH200RPL Intelligent Low-Flow Duct Smoke Detector to be used with compatible control panels. The duct smoke detector shall be UL listed per UL 268A, Standard for Smoke Detectors for Duct Applications, specifically for use in air handling systems. The detector shall operate in air velocities from 100 to 4000 feet per minute. The detec-

tor shall be an intelligent photoelectronic detector. It shall be capable of local testing via magnetic switch or remote testing from the RTS451 or RTS451KEY Remote Test Station. The duct smoke detector housing shall incorporate an airtight smoke chamber in compliance with UL 268A. The housing shall be capable of mounting to either rectangular or round ducts without adapter brackets. An integral filter system

shall be included to reduce dust and residue effects, thereby reducing maintenance and servicing. Sampling tubes shall be easily installed after the housing is mounted to the duct by passing through the duct housing. Terminal connections shall be of the strip and clamp method suitable for 12-18 AWG wiring.

DH200PL Specifications

Voltage Range

15 to 32 VDC

Standby Current

300µA @ 24 VDC (one communication every 5 seconds with LED blink enabled)

Accessory Current Loads

Device	Standby	Alarm
RA400Z	0 mA	10 mA Max.
RTS451/RTS451KEY	0 mA	7.5 mA Max.

Wiring diagram for DH200PL Duct Smoke Detector using a UL listed control panel

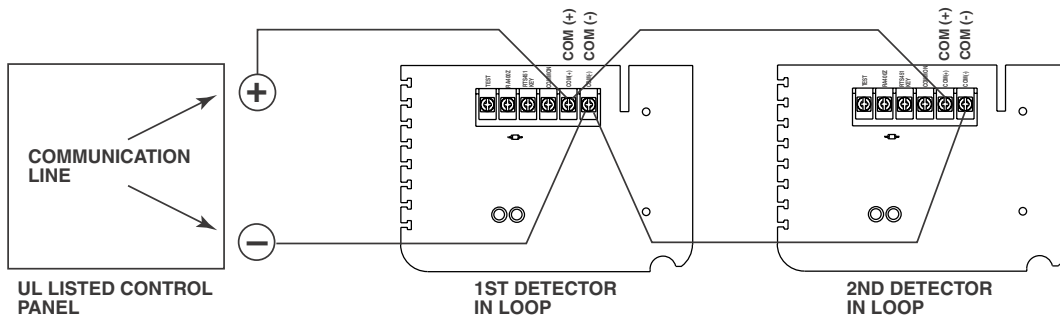

Wiring diagram for DH200PL Duct Smoke Detector with optional RA400Z

(Must break tab on back of RA400Z when used with DH200PL.)

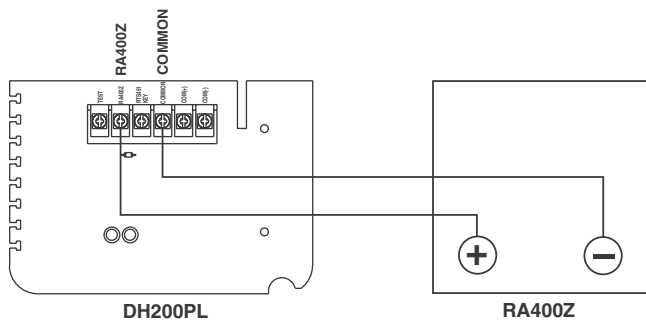

Wiring diagram for DH200PL Duct Smoke Detector with RTS451/RTS451KEY

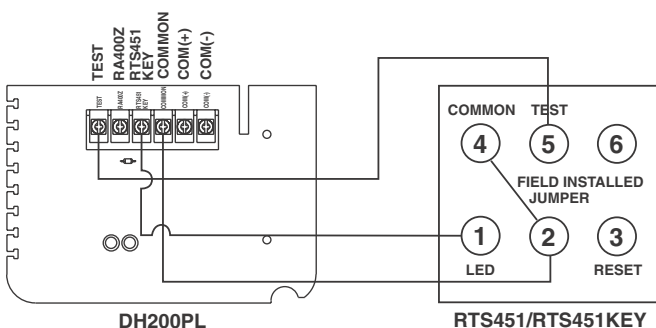

FOR RTS451, TERMINAL 3 IS NOT USED.
 (RTS451 DOES NOT HAVE A TERMINAL 6.)
 FOR RTS451KEY, TERMINALS 3 AND 6 ARE NOT USED.

DH200RPL Specifications

Current Requirements (using no accessories)

Power supply voltage	20-30 VDC	24 VAC, 50-60Hz	120VAC, 50-60Hz	220/240 VAC, 50-60Hz
Max. standby current	26 mA	65 mA RMS	44 mA RMS	25 mA RMS
Max. alarm current	87 mA	182 mA RMS	52 mA RMS	30 mA RMS
Alarm response time	3 to 10 sec.	3 to 10 sec.	3 to 10 sec.	3 to 10 sec.
Power up time	2 sec.	2 sec.	2 sec.	2 sec.

Contact Ratings

Alarm auxiliary contacts* (DPDT)
 10 A @ 30 VDC
 10 A @ 277 VAC (0.75 power factor)
 240 VA @ 249 VAC (0.4 power factor)
 ½ HP @ 120 VAC
 ¼ HP @ 240 VAC

Supervisory contact (SPST)

2.0 A @ 30 VDC (resistive)

*Minimum switching current for auxiliary contact must be 100 mA DC minimum @ 5 VDC.

Accessory Current Loads at 24 VDC

Device	Standby	Alarm
PA400	0 mA	15 mA Max.
RA400Z	0 mA	12 mA Max.
RTS451/RTS451KEY	0 mA	10 mA Max.

Wiring diagram for DH200RPL Duct Smoke Detector using a UL listed control panel

NOTE: Jumper J1 shunt must be installed for 2-W applications. J1 shunt must be removed for power PCB supervision.

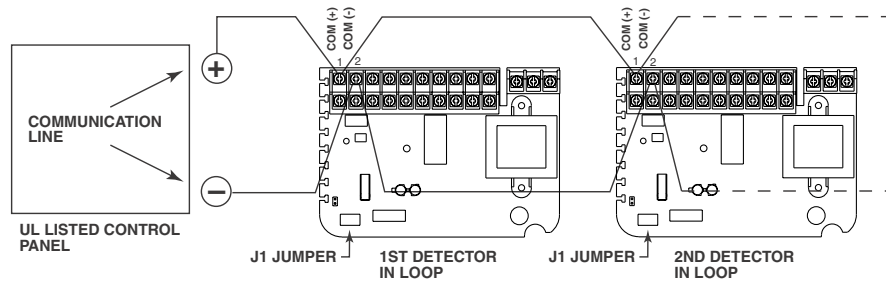

NOTE: External power of 24V AC/DC or 120/220 VAC must be connected in order to power all remote horn or strobe accessories.

Wiring diagram for DH200RPL Duct Smoke Detector with optional RA400Z

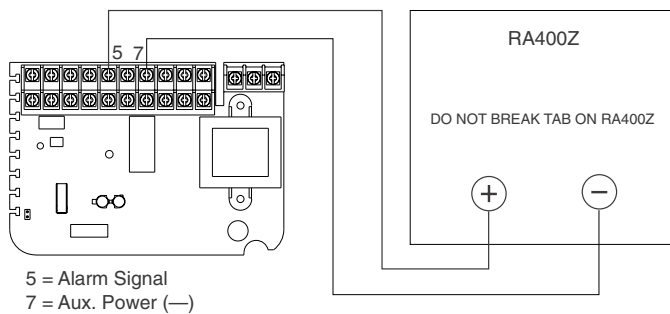

Wiring diagram for DH200RPL Duct Smoke Detector with optional RTS451/RTS451KEY

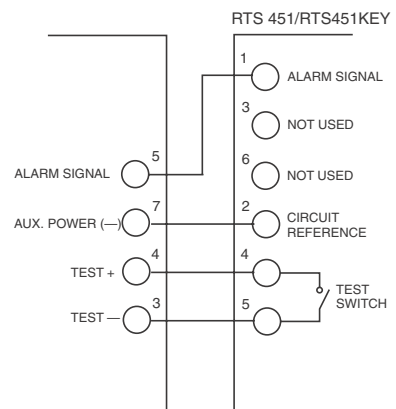

FOR RTS451, TERMINAL 3 IS NOT USED. (RTS451 DOES NOT HAVE A TERMINAL 6.) FOR RTS451KEY, TERMINALS 3 AND 6 ARE NOT USED.

Wiring diagram for DH200RPL Duct Smoke Detector with optional PA400

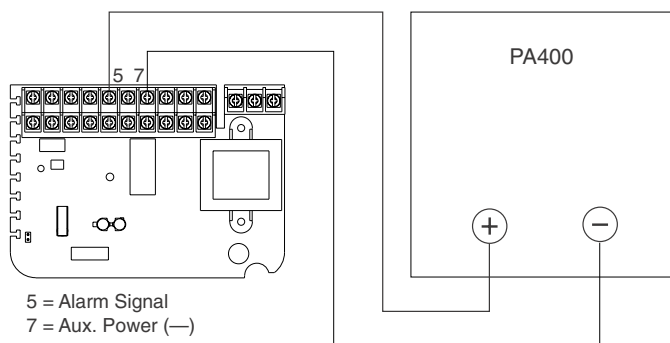

Innovair™ 200 Series Low-Flow Specifications

Operating Temperature Range

32° to 131°F (0° to 55°C)

Operating Humidity Range

10% to 93% relative humidity
(non-condensing)

Storage Temperature Range

-22° to +158°F (-30° to +70° C)

Duct Air velocity

100 – 4000 ft./min. (0.5 – 20.32 m/s)

Shipping Weight

DH200PL: 3.35lbs. (1.5 kg)

DH200RPL: 3.90lbs. (1.8 kg)

Length

14¾" (37 cm)

Width

5½" (14 cm)

Depth

2¾" (7 cm)

Ordering Information

Part No.	Description	Accessories	Description
DH200PL	Innovair™ intelligent low-flow photoelectric non-relay duct smoke detector	RTS451	Remote test station (see below)
DH200RPL	Innovair™ intelligent low-flow photoelectric with relay duct smoke detector	RTS451KEY	Remote test station w/key (see below)
ST-1.5	Metal sampling tube duct widths 1'–2'	RA400Z	Remote LED (see below)
ST-3	Metal sampling tube duct widths 2'–4'	PA400	Mini-Alert™ Sounder (see below)
ST-5	Metal sampling tube duct widths 4'–8'	F36-09-11	Replacement filters
ST-10	Metal sampling tube duct widths 8'–12'	M02-04-00	Test magnet
A5053	Replacement photoelectric sensor board	P48-21-00	End cap for metal sampling tube
A5060	Replacement power board for DH200RPL (w/relay)	P48-61-00	End cap for plastic sampling tube
A5067	Replacement power board for DH200PL (w/o relay)	S08-39-01	Replacement photo insect screen
		T80-71-00	Replacement plastic sampling tube

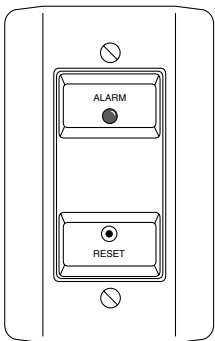

RTS451

Remote Test Station
(UL S2522)

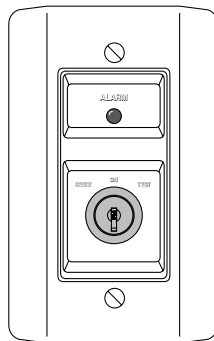

RTS451KEY

Remote Test Station with
key (UL S2522)

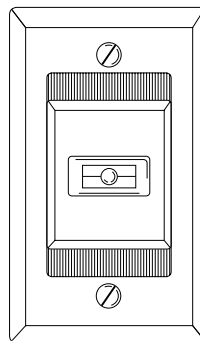

RA400Z

Remote
Annunciator
(UL S2522)

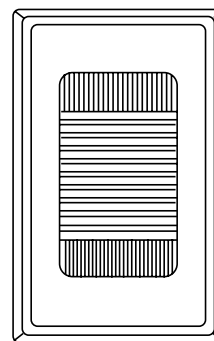

PA400

Mini-Alert™ Sounder
(UL S3593)
Device cannot be wired
directly to DH200PL
(non-relay).

System Sensor Sales and Service

System Sensor Headquarters

3825 Ohio Avenue
St. Charles, IL 60174
Ph: 800/SENSOR2
Fx: 630/377-6495
Documents-on-Demand
800/736-7672 x3
www.systemsensor.com

System Sensor Canada

Ph: 905.812.0767
Fx: 905.812.0771

System Sensor Europe

Ph: 44.1403.276500
Fx: 44.1403.276501

System Sensor in China

Ph: 86.29.524.6253
Fx: 86.29.524.6259

System Sensor in Singapore

Ph: 65.6273.2230
Fx: 65.6273.2610

System Sensor – Far East

Ph: 85.22.191.9003
Fx: 85.22.736.6580

System Sensor – Australia

Ph: 613.54.281.142
Fx: 613.54.281.172

System Sensor – India

Ph: 91.124.637.1770 x.2700
Fx: 91.124.637.3118