

Radiation Hardened Octal Three-State Transparent Latch

Intersil's Satellite Applications Flow™ (SAF) devices are fully tested and guaranteed to 100kRAD total dose. These QML Class T devices are processed to a standard flow intended to meet the cost and shorter lead-time needs of large volume satellite manufacturers, while maintaining a high level of reliability.

The Intersil ACTS573T is a Radiation Hardened Octal Transparent Latch with an active low output enable. The outputs are transparent to the inputs when the latch enable (LE) is High. When the latch goes low the data is latched. The output enable controls the three-state outputs. When the output enable pins (OE) are high the output is in a high impedance state. The latch operation is independent of the state of output enable.

Specifications

Specifications for Rad Hard QML devices are controlled by the Defense Supply Center in Columbus (DSCC). The SMD numbers listed below must be used when ordering.

Detailed Electrical Specifications for the ACTS573T are contained in SMD 5962-96725. A "hot-link" is provided from our website for downloading.

www.intersil.com/spacedefense/newsafclasst.asp

Intersil's Quality Management Plan (QM Plan), listing all Class T screening operations, is also available on our website.

www.intersil.com/quality/manuals.asp

Ordering Information

ORDERING INFORMATION	PART NUMBER	TEMP. RANGE (°C)
5962R9672502TRC	ACTS573DTR-02	-55 to 125
5962R9672502TXC	ACTS573KTR-02	-55 to 125

NOTE: **Minimum order quantity for -T is 150 units through distribution, or 450 units direct.**

Features

- QML Class T, Per MIL-PRF-38535
- Radiation Performance
 - Gamma Dose (γ) 1×10^5 RAD(Si)
 - Latch-Up Free Under Any Conditions
 - Single Event Upset (SEU) Immunity: $<1 \times 10^{-10}$ Errors/Bit/Day (Typ)
 - SEU LET Threshold >100 MEV-cm²/mg
- 1.25 Micron Radiation Hardened SOS CMOS
- Significant Power Reduction Compared to ALSTTL Logic
- DC Operating Voltage Range 4.5V to 5.5V
- Input Logic Levels
 - $V_{IL} = 0.8V$ Max
 - $V_{IH} = V_{CC}/2$ Min
- Fast Propagation Delay 18ns (Max), 12ns (Typ)

Pinouts

ACTS573T (SBDIP), CDIP2-T20
TOP VIEW

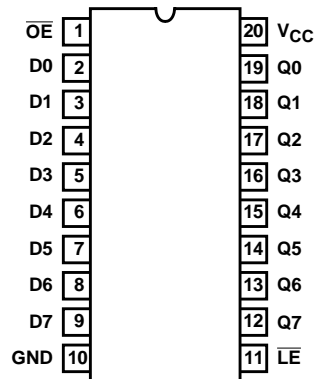

ACTS573T (FLATPACK), CDFP4-F20
TOP VIEW

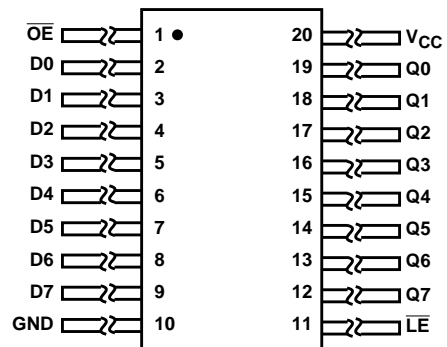

Functional Diagram

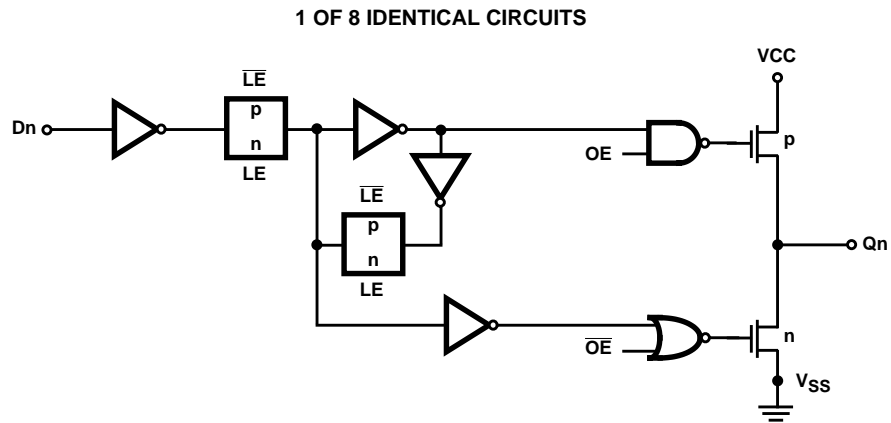

COMMON CONTROLS

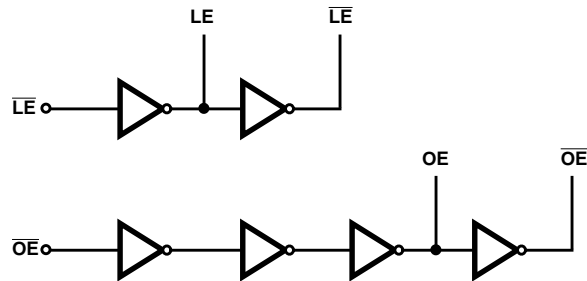

TRUTH TABLE

OE	LE	DATA	OUTPUT
L	H	H	H
L	H	L	L
L	L	l	L
L	L	h	H
H	X	X	Z

NOTE: L = Low Logic Level, H = High Logic Level, X = Don't Care, Z = High Impedance, l = Low Voltage Level Prior to High-to-Low Latch Enable Transition, h = High Voltage Level Prior to High-to-Low Latch Enable Transition.

Die Characteristics

DIE DIMENSIONS:

(2600µm x 2600µm x 533µm ±51µm)
 102 x 102 x 21mils ±2mil

METALLIZATION:

Type: Al Si Cu
 Thickness: 10kÅ ±2kÅ

SUBSTRATE POTENTIAL:

Unbiased (Silicon on Sapphire)
 Bond Pad #20 First

BACKSIDE FINISH:

Sapphire

PASSIVATION:

Type: Silox (SiO₂)
 Thickness: 8kÅ ±1kÅ

WORST CASE CURRENT DENSITY:

< 2.0e5 A/cm²

TRANSISTOR COUNT:

190

PROCESS:

CMOS SOS

Metalization Mask Layout

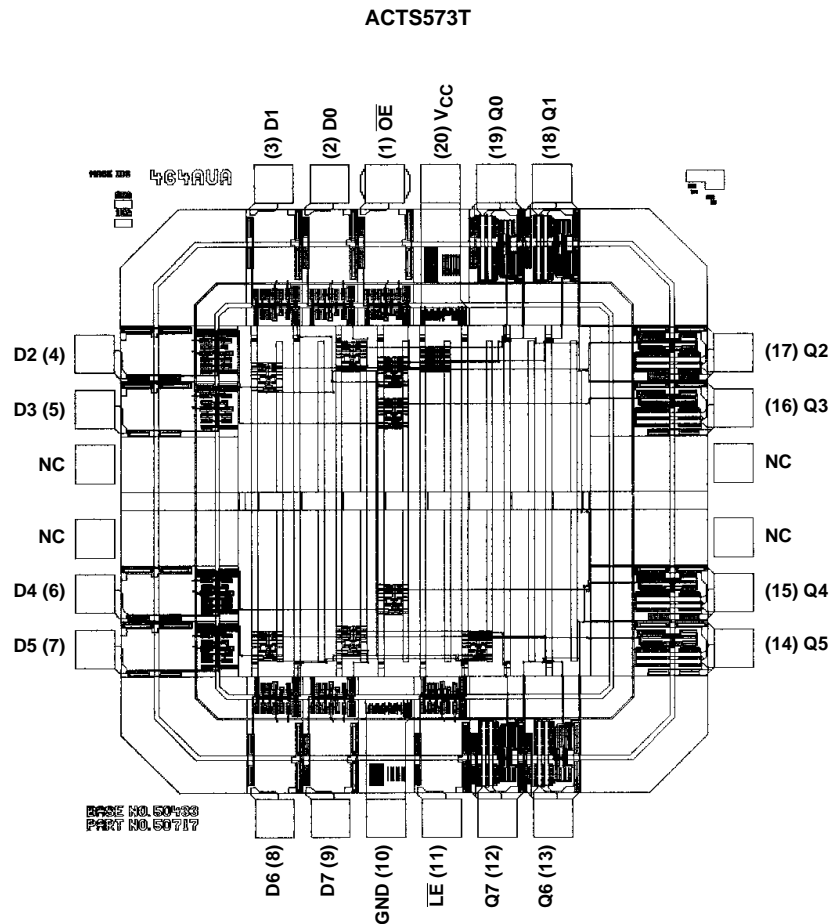

All Intersil semiconductor products are manufactured, assembled and tested under **ISO9000** quality systems certification.

Intersil semiconductor products are sold by description only. Intersil Corporation reserves the right to make changes in circuit design and/or specifications at any time without notice. Accordingly, the reader is cautioned to verify that data sheets are current before placing orders. Information furnished by Intersil is believed to be accurate and reliable. However, no responsibility is assumed by Intersil or its subsidiaries for its use; nor for any infringements of patents or other rights of third parties which may result from its use. No license is granted by implication or otherwise under any patent or patent rights of Intersil or its subsidiaries.

For information regarding Intersil Corporation and its products, see web site <http://www.intersil.com>