

Part No. AL-30-01UWC Diff No.

7.62 mm SUPER FLUX WHITE LED Type LED Lamps

High Power LED

MODEL NO: AL-30-01UWC

Page: 1/4

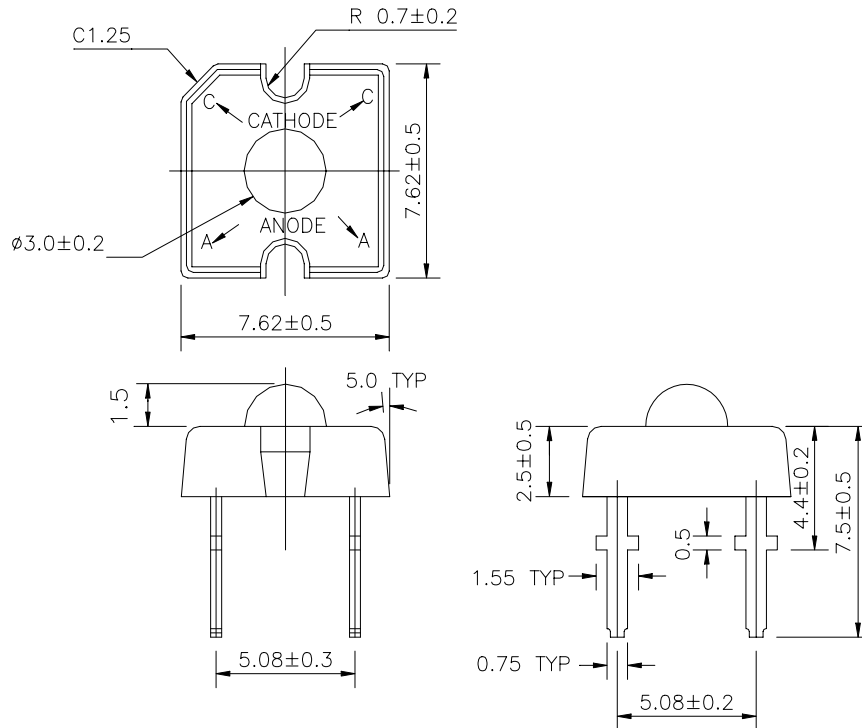
Package Dimensions: Notes: All dimensions are in millimeters.

Part No. AL-30-01UWC Diff No.

7.62mm SUPER FLUX WHITE LED Type LED Lamps

High Power LED

MODEL NO: AL-30-01UWC

Page: 2/4

■ Absolute Maximum Ratings*

Parameter	Symbol	Rating	Units
Forward Current	I_F	30	mA
Pulse Forward Current ^{*1}	I_{FP}	100	mA
Reverse Voltage	V_R	5	V
Power Dissipation	P_D	120	mW
Operating Temperature	T_{opr}	-30 ~ +80	°C
Storage Temperature	T_{stg}	-40 ~ +100	°C
Soldering Temperature ^{*2}	T_{sol}	260	°C

*1. I_{FP} Conditions--Pulse Width ≤ 10 msec and Duty $\leq 1/10$ *2. Soldering time ≤ 5 seconds**■ Electro-Optical Characteristic (Ta=25°C)**

Parameter	Symbol	Condition	Min.	Typ.	Max.	Units
Forward Voltage	V_F	$I_F=20$ mA		3.5	4.2	V
Reverse Current	I_R	$V_R=5$ V	--	--	10	μ A
Brightness	I_V	$I_F=20$ mA	250	500	--	mcd
Viewing Angle	2θ 1/2	$I_F=20$ mA	--	70	--	deg
Chromaticity	X	$I_F=20$ mA		0.29		
Coordinates	y			0.30		

Part No. AL-30-01UWC Diff No.

7.62mm SUPER FLUX WHITE LED Type LED Lamps

High Power LED

MODEL NO: AL-30-01UWC

Page: 3/4

■Reliability Test Conditions

NO.	Condition	Test Condition	Test Hour/ Cycle	Sample Size	Accept/ Reject
1	Room Temperature DC Operating Life	Ta=25°C If=20mA	1000hrs	80PCS	0/1
2	Thermal Shock	-10°C (5min)→ (10sec) →+100°C (5min)	100cycles	80PCS	0/1
3	Temperature Cycle	-40°C (30min)→ (5min) →+85°C (30min)	100cycles	80PCS	0/1
4	High Temperature/ High Humidity Test	85°C/ 85%RH	1000hrs	80PCS	0/1
5	High Temperature Storage	Ta=100°C	1000hrs	80PCS	0/1
6	Low Temperature Storage	Ta=-40°C	1000hrs	80PCS	0/1
7	Solder Heat	260°C± 5°C	5secs	80PCS	0/1

Part No. AL-30-01UWC Diff No.

7.62 mm SUPER FLUX WHITE LED Type LED Lamps

High Power LED

MODEL NO: AL-30-01UWC

Page: 4/4

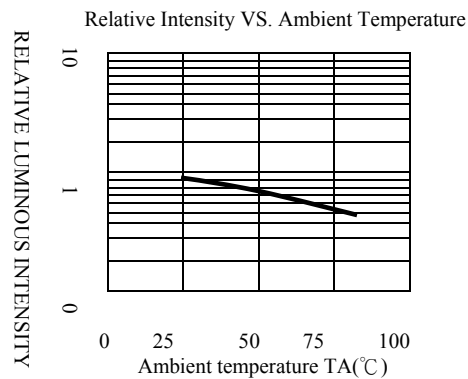
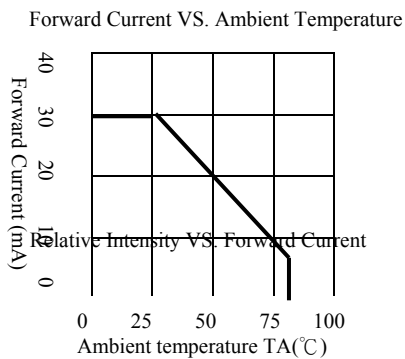
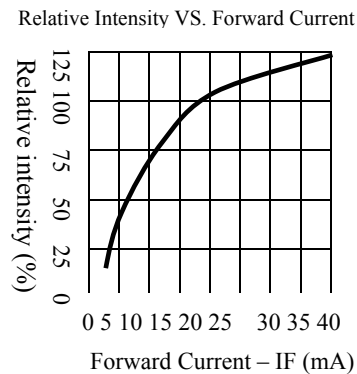
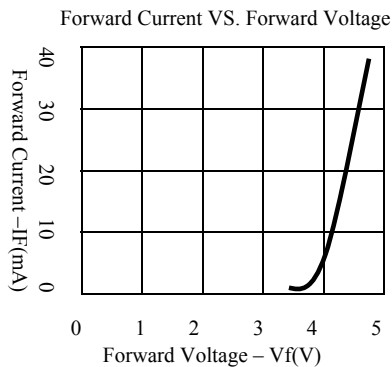
Typical Electro-Optical Characteristics Curves

●Directivity Radiation Angle: 70 degree (Typ.)

