

# **TMPA8821 Series**

# Application Note

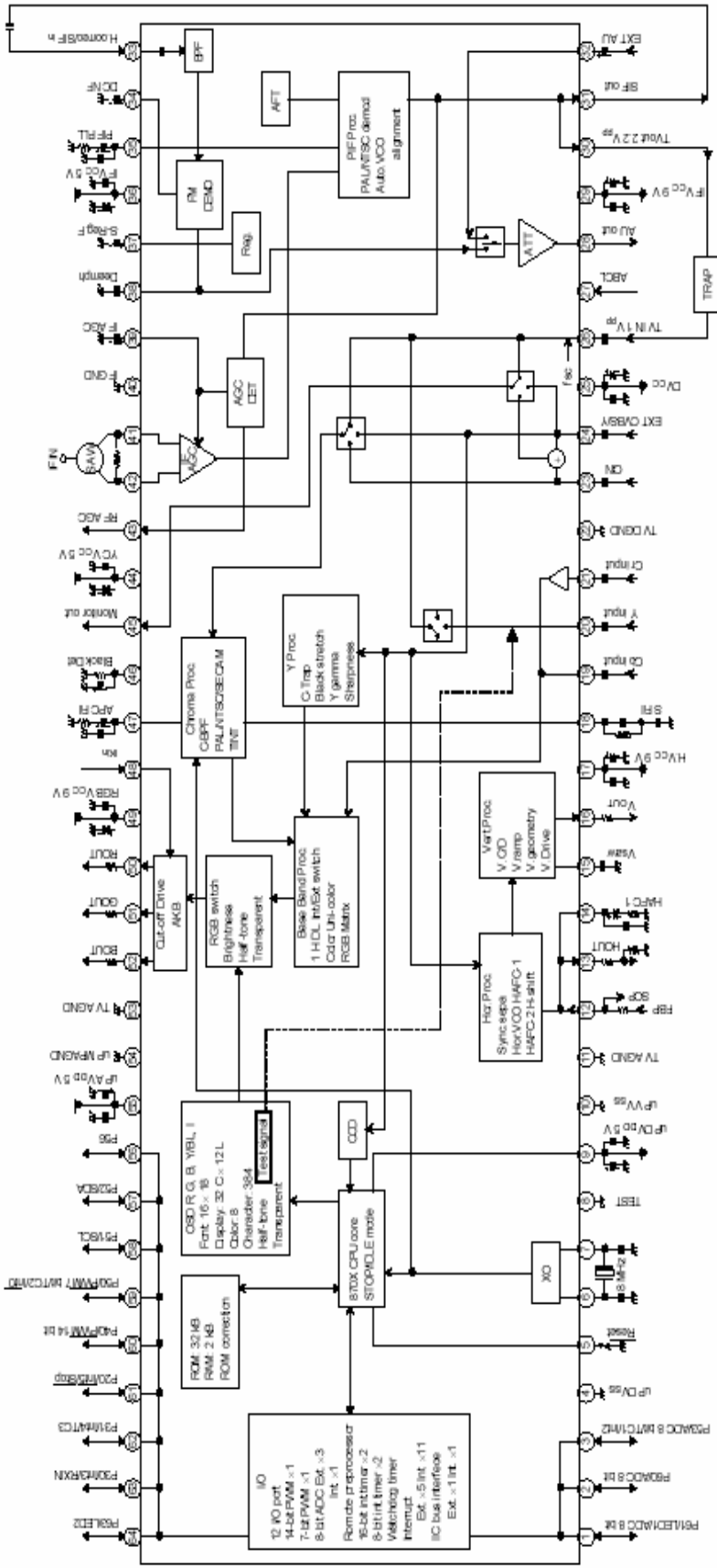

Block Diagram





## Lead the feet description

Pin number	Pin Name	Signal Name	I/O	Logic	Funtion
1	P61	BAND1	OUT	Positive	BAND data output 1
2	P60	BAND2	OUT	Positive	BAND data output 2
3	P53	KEY	IN	Negative	Key input
4	VSS	VSS	-		GND connection
5	/RESET	/RESET	IN	Negative	Reset signal input
6	XOUT	XOUT	OUT	-	8 MHz oscillator connection
7	XIN	XIN	IN	-	8 MHz oscillator connection
8	TEST	TEST	IN	Positive	GND connection
9	VDD	VDD	IN		5V power supply
10	VSS	VSS	-		GND connection
54	VSS	VSS	-	-	GND connection
55	VDD	VDD	IN	-	5V power supply
56	P56	TV/AV1/AV2	OUT	Positive	SWITCH
57	P52	SDA1	I/O	Positive	IIC-BUS SDA1
58	P51	SCL1	OUT	Positive	IIC-BUS SCL1
59	P50	VOLUME	OUT	Positive	PWM8 OUT VOLUME
60	P40	VT	OUT	Negative	VT output
61	P20	MUTE	OUT	Positive	MUTE OUTPUT
62	P31	H.SYNC	IN	Negative	Horizontal sync signal input
63	P30	REMOTE	IN	Negative	Remote controller signal input
64	P63	POWER	I/O	Negative	Power control & Check, On=Hi-Z(input),Off=L(output)
Int	P64(R)	R	OUT	Positive	OSD R signal output
Int	P65(G)	G	OUT	Positive	OSD G signal output
Int	P66(B)	B	OUT	Positive	OSD B signal output
Int	P67(Y)	Y	OUT	Positive	OSD Y signal output
Int	P70(HD)	HD	IN	Negative	OSD HD signal input
Int	P71(VD)	VD	IN	Positive	OSD VD signal input
Int	P32	VIN1/CSIN	OUT	Positive	SIF data output1
Int	P33	VIN0/TC4	OUT	Positive	SIF data output2
Int	P34(SCL0)	SCL0	OUT	Positive	IIC-BUS SCL0
Int	P35(SDA0)	SDA0	I/O	Positive	IIC-BUS SDA0
Int	P54	AIN1/KWU1	IN	Positive	
Int	P57	I	OUT	Positive	OSD I signal output
Int	CLKOUT			Positive	
NC	P41~P47		IN	Positive	NON Connection
NC	P55		IN	Positive	NON Connection
NC	P62		IN	Positive	NON Connection

## Remote control key

0x2a	0x2b S. SYS	0x2c Factory 1	0x2d Factory 2	0x2e	0x2f
0x24 SCAN	0x25 RECALL	0x26	0x27 CALENGAR	0x28	0x29



0x1e AUDIO	0x1f WIDE	0x20 GAME	0x21 FAV	0x22 FAV SCAN	0x23
0x18 ↓	0x19 ↑	0x1a ←	0x1b →	0x1c MENU	0x1d Picture MENU
0x12 V-	0x13 V+	0x14 MUTE	0x15 SLEEP	0x16 DISPLAY	0x17 STEREO
0x0c C.System	0x0d I/II (Audio)	0x0e P. P	0x0f AV/TV	0x10 P-	0x11 P+
0x06 7	0x07 8	0x08 9	0x09 0	0x0a -/-/-	0x0b POWER
0x00 1	0x01 2	0x02 3	0x03 4	0x04 5	0x05 6

## The software adjusts to try the data elucidation

TMPA8821-5UD2 Adjust to try the data watch

### MENU 01

	MENU	int	Contents		
0	OSD	16	OSD Horizontal Position		
1	OPT	1F	BIT	Optional Setting	
			0	RUSSIAN	1: ON 0: OFF
			1	ARABIC	1: ON 0: OFF
			2	FRENCH	1: ON 0: OFF
			3	TURKISH	1: ON 0: OFF
			4	PERSIAN	1: ON 0: OFF
			5	No sync aft, Not VT Down of AFT when No Singal (=1)	
6/7	Video IF Select 00:38MHz 10: 45.75MHz 01/11: 38.9				
2	RCUT	40	R Cut off	00:-0.65V, 80:0V, FF:0.65V	
3	GCUT	3D	G Cut off	00:-0.65V, 80:0V, FF:0.65V	
4	BCUT	55	B Cut off	00:-0.65V, 80:0V, FF:0.65V	
5	GDRV	40	G Drive Gain	00:-4.5dB, 40:0dB, 7F:3.5dB	
6	BDRV	40	B Drive Gain	00:-4.5dB, 40:0dB, 7F:3.5dB	
7	HPOS	0A	50Hz Horizontal position		
8	VP50	05	50Hz Vertical phase		
9	HIT	13	50Hz Vertical size		

### MENU 02

	MENU	int	Contents	
0	HPS	02	60Hz Horizontal position	
1	VP60	02	60Hz Vertical phase	
2	HITS	00	60Hz Vertical size	
3	VLIN	0D	50Hz Vertical linearity	
4	VSC	03	60Hz Vertical linearity	
5	VLIS	FF	60Hz Vertical linearity	
6	VSS	01	Shift data of 50Hz/60Hz	
7	CAL BOX	84	CAL box color	
8	MENU UP BOX	82	MENU UP box color	



9	MENU DOWN BOX	94	MENU DOWN box color
---	---------------	----	---------------------

**MENU 03**

	MENU	int	Contents
0	BAR BOX	8C	BAR box color
1	GAME BOX	1C	GAME box color
2	TINT BOX	00	TINT box color
3	FONT BOX	0A	FONT box color
4	SYS BOX	89	SYS MENU box color
5	SBY	09	SECAM B-Y
6	SRY	09	SECAM R-Y
7	RAGC	28	RF AGC 00:IF mute, 01:67dBu, 3F:107dBu
8	V01	04	Volume output data when volume=1
9	V25	28	Volume output data when volume=25

**MENU 04**

	MENU	int	Contents	
0	V50	44	Volume output data when volume=50	
1	V100	60	Volume output data when volume=100	
2	MODE0	F4	BIT	Contents elucidation
			0/1	Opening the machine postpones the hour 1: use 0: unused
			2	SECAM 1: use 0: unused
			3	0: PAL-M/PAL-N/SECAM auto 1: BIT2=0 PAL auto
			4	Fjp_pos 1: 200 0: 100
			5	Change the pedestal black hold the manifestation of OSD 1: use 0: unused
			6	Fjp_menu_key. 0: POS Up/Down, VOL Up/Down; 1: It is the same as the direction key (0:different 1:same)
			7	audio gain sw 1: use 0: unused
3	MODE1	E3	BIT	Contents elucidation
			0	Set 1
			1	WOOF gain sw: 1: on 0: off
			2	DISP Key Function. 0:Timer Display(4S); 1:Always Display
			3	TINT 1: on 0: off
			4	TINT polarity, input to V/C/D. 0:normal 1:invert
			5	Set 1
			6/7	SHOP OUT 01: BG 10: I 11: DK 00: unused
4	MODE2	7E	BIT	Contents elucidation
			0	Sound M .0: unused 1:use
			1	Sound I .0: unused 1:use
			2	Sound B/G .0: unused 1:use
			3	Sound D/K .0: unused 1:use
			4	PIF VCO request;0: when power on, ASM & search;1:when only power on
			5	Tuning Algorithm option 1.0: ASM doesn't judge IFLOCK with case 4;1: ASM judge IF LOCK with case 4
			6	Tuning Algorithm option 2.0: ASM doesn't judge



				Fhsync with case 4;1: ASM judge Fhsync with case 4
			7	Synchronous separation level 0: 40 % 1: 36 %
5	PDOPT0	F6	BIT	Contents elucidation
			0	Set 0
			1	RFAG 1:use 0:nouse
				AV mode RFAGC=1 AV mode RFAGC=0
			2	Set 1 (RNP 1:open 0:close)
			3	audio frequency solution adjusts to increase the benefit enactment 0: 50KHz 1: 25KHz
			4	Surround menu bar. 1:use 0:nouse
			5	Factory menu a language choice 0: Chinese 1: English
			6	Open screen 1: on 0: off
	7	Close screen 1: on 0: off		
6	PDOPT1	9E	BIT	Contents elucidation
			0	Screen saver 1: on 0: off
			1	LOGO 1: on 0: off
			2	Av sound mute (no signal). 1:use 0:nouse
			3	Set 1
			4/5/6	Language priority display PERSIAN
				001: English 010: Russian 011: Arabic
				100: French 101: Turkish 111: Turkish
				110: Persian
			7	Change the pedestal mute 1: mute 0: off
7	VTST	9E	BIT	Contents elucidation
			0	cfg CALENDAR and wild_screen key exchange on/off, 1:on 0:off
			1	no signal chooses the set to operate 0:no signal continue get down to choose 1:Don't choose
			2	After menu break whether return to start position 0:Don't return 1:Return
			3	GAME menu bar. 1:use 0:nouse
			4	CALENDAR menu bar. 1:use 0:nouse
			5	Set 0
			6	Fjp_ Sanyo and Toshiba key 1: Sanyo 0: Toshiba
	7	Change the pedestal Black hold 1: use 0: unused		
8	FLG1	7E	BIT	Contents elucidation
			0	8821stereo/Mono 0: Stereo1: Mono
			1	Set 0
			2	Set 0
			3	Child_lock 1: on 0: off
			4	GAME 1: on 0: off
			5	CALENGAR 1: on 0: off
			6	Set 0
			7	search start post ion function,



				1:now post ion 0: 0 post ion
9	VCEN	0B	V Centering	

Sanyo key: (VTST BIT7 step1)

PIN	Electric voltage scope	KEY	Function elucidation
KEY 3 IN	4/32VDD~7/32VDD	CH+	CH+
	8/32VDD~11/32VDD	CH-	CH-
	12/32VDD~15/32VDD	VOL+	VOL+
	16/32VDD~19/32VDD	VOL-	VOL-
	20/32VDD~23/32VDD	MENU	MENU
	24/32VDD~27/32VDD	TV/AV	TV/AV

**MENU 05**

	MENU	int	Contents
0	CNTX	7F	SUB CONTRAST MAX
1	BRTC	4A	SUB BRIGHT CENTER
2	COLC	45	SUB COLOR CENTER for NTSC
3	TNTC	40	SUB TINT CENTER
4	COLP	00	SUB COLOR CENTER for PAL(DIFFERENCE)
5	COLS	45	SUB COLOR CENTER for SECAM
6	DCOL	45	DVD COLOR
7	SCOL	04	SUB COLOR CENTER for DVD
8	SCNT	0B	Y-SUB CONTRAST
9	CNTC	4A	SUB CONTRAST CENTER

**MENU 06**

	MENU	int	Contents
0	CNTN	08	SUB CONTRAST MINIMUM
1	BRTX	20	SUB BRIGHT MAX(DIFFERENCE)
2	BRTN	30	SUB BRIGHT MINIMUM(DIFFERENCE)
3	COLX	3F	SUB COLOR MAX(DIFFERENCE)
4	COLN	00	SUB COLOR MINIMUM
5	TNTX	28	SUB TINT MAX(DIFFERENCE)
6	TNTN	28	SUB TINT MINIMUM(DIFFERENCE)
7	ST3	19	SUB SHARP CENTER NTSC3.58 in TV
8	SV3	28	SUB SHARP CENTER NTSC3.58 in VIDEO
9	ST4	28	SUB SHARP CENTER other color system in TV

**MENU 07**

	MENU	int	Contents	
0	SV4	28	SUB SHARP CENTER other color system in VIDEO	
1	SVD	28	SUB SHARP CENTER in DVD	
2	ASSH	07	ASYMMETRY-SHARPNESS	
3	SHPX	1A	SUB SHARPNESS MAX points from Center value	
4	SHPN	1A	SUB SHARPNESS MIN points from Center value	
5	TXCX	1F	RGB Contrast data at MAX data of user contrast	
6	RGCN	00	RGB Contrast data at MIN data of user contrast	
7	ABL	26	BIT	ABL data in detail
			0/1	ABL Gain 00:-0.17V 01:-0.35V 10:-0.50V
			2/3	ABL Start Point 00:0V 01:-0.15V 10:-0.28V
			4	YPL 0:Y peak limiter on,105IRE, 1: Y peak limiter off
			5	RGB OSD ABL 0:ABL active for OSD 1:Inactive
			6	Set 0
			7	Set 0
8	DCBS	2A	A part of Video data in detail	
			Bit:0/1 Black Stretch , bit:4/5 OSD Contrast	
9	CLT0	5D	COLOR MODE (TV OTHER)	



## MENU 08

	MENU	int	Contents				
0	CLTM	5C	COLOR MODE (TV M SYSTEM)				
1	CLVO	4C	COLOR MODE (VIDEO OTHER)				
2	CLVD	5C	COLOR MODE (DVD)				
3	DEF	01	DEF MODE				
4	AKB	00	AKB MODE				
			00: AKB OFF	01: ACB	10: ADB	11: AKB	
5	SECD	08	BIT	SECAM MODE data in detail			
			0	S-ID Sens			
			1	Bell fo	0: Normal enactment	1: +35KHz	
			2	S-ID Mode	0: Horizontal	1: Horizontal/ Vertical	
			3/4	SECAM (The choice sets up)			
				11: no SECAM	00: 2.2us	01: 2.0us	10: 1.8us
			5	Set 0			
			6	Set 0			
7	Set 0						
6	VEHT	06	nouse				
7	HEHT	01	nouse				
8	BRTS	00	SUB Brightness(DIFFERENCE)				
9	HAFC	09	1/2 AFC data adjustment				

## MENU 09

	MENU	int	Contents				
0	MUTT	00	CONTRAST UP FOR SOFT MUTT				
1	STAT	00	CONTRAST UP FOR SOFT START				
2	FLG0	6E	BIT	Contents elucidation			
			0	Set 0			
			1	factory adjusts D Mode BPF/TOF Setup 0: BPF1: TOF			
			2	Set 0			
			3	MIX GAIN	1: HIGH GAIN		
				0: SIF 1MHZ CONVERT GAIN, LOW GAIN			
			4	Set 0			
			5	Set 0			
6	Set 0						
7	Set 0						
3	REFP	00	REF Pulse Position				
4	RSNS	00	R SENS				
5	GSNS	00	G SENS				
6	BSNS	00	B SENS				
7	MOD	00	Set 0				
8	STBY	00	BIT	VCD/IF Standby			
			0/1	11: IF STANDBY			
			2/3	11: V/C/D STANDBY			
			4	Set 0			
			5	Set 0			
			6	Set 0			
			7	Set 0			
			9	SVM	06	BIT	SVM GAIN
	00: -6DB	01: 0DB				10: +6DB	11: +12DB
2/3	SVM DL						
	00: OFF	01: -100NS				10: -80NS	11: -60NS
4	CO MAX	0: (-0.65.+0.65)				1: (-0.65+0.85)	





			5	Set 0
			6	Set 0
			7	Set 0

**MENU 10**

	MENU	int	Contents				
0	SVM1	06	VSM MODE (MAMORY 1) CONTRAST: 0-49				
1	SVM2	06	VSM MODE (MAMORY 2) CONTRAST: 50-100				
2	SVM3	06	VSM MODE (MAMORY 2) CONTRAST: 0-49 (MAMORY 3)				
3	VBLK	00	BIT	V BLK Start / Stop			
			0/1	VBLK stop 50HZ/60Hz			
				00: 23H/22H 01: 33H/30H 10: 37H/34H 11: 41H/38H			
			2/3	VBLK open 50HZ/60Hz			
				00: 310H/263H 01: 299H/254H			
				10: 295H/250H 11: 291H/246H			
			4	Set 0			
			5	Set 0			
6	Set 0						
7	Set 0						
4	UCOM	00	Set 0				
5	PYNX	28	H.SYNC MAX in normal condition				
6	PYNN	18	H.SYNC MIN in normal condition				
7	PYXS	22	H.SYNC MAX in search				
8	PYNS	1E	H.SYNC MIN in search				
9	WCTL	41	BIT	for A-PRO data setting			
			0/1	woofer fc			
				00: 100Hz 01: 125Hz 10: 170Hz 11: 210Hz			
			2	input attenuator 0:0dB, 1:-5dB			
			3/4	ALS start point			
				00: 220mv 01: 380mv 10: 525mv 11: 770mv			
			5	ALS SW 0:off, 1:on			
			6	bass boost SW 0:off, 1:on			
7	Set 0						

**MENU 11**

	MENU	int	Contents			
0	SUR1	06	MONO SURROUND MODE			
1	SUR2	04	STORE 1 SURROUND MODE			
2	SUR3	07	STORE 2 SURROUND MODE			
3	BASC	48	BASS Center			
4	BASX	72	BASS MAX			
5	TREC	42	TREBLE Center			
6	BALC	40	BALANCE Center			
7	WOFC	40	WOOFER Center			
8	BAS1	CB	BASS data in "Music"		Bit0-6: Bass level,	bit7:Surround select.0
9	BAS2	3C	BASS data in "News"		Bit0-6: Bass level,	bit7:Surround select.0

**MENU 12**

	MENU	int	Contents			
0	BAS3	CB	BASS data in "Theater"		Bit0-6: Bass level,	bit7:Surround select.0
1	TRE1	55	TREBLE data in "Music"		Bit0-6: Treble level,	bit7:Surround select.1
2	TRE2	37	TREBLE data in "News"		Bit0-6: Treble level,	bit7:Surround select.1
3	TRE3	A8	TREBLE data in		Bit0-6: Treble level,	bit7:Surround select.1
4	WLF1	CB	Woofer data in "Music"		Bit0-6: Woofer level,	bit7:Woofer On/Off
			1:On 0:Off			
5	WLF2	99	Woofer data in "News"		Bit0-6: Woofer level,	bit7:Woofer On/Off
			1:On 0:Off			



6	WLF3	E4	Woofer data in "Theater" Bit0-6: Woofer level, bit7:Woofer On/Off 1:On 0:Off
7	WON1	02	Woofer output level For the calculation of the Woofer output value
8	WON2	09	Woofer output level For the calculation of the Woofer output value.
9	WOFF	00	Woofer output level A Woofer output level in Woofer off.

**MENU 13**

	MENU	int	Contents
0	COM1	04	BIT 0-2: VENH data BIT 3: PDSOFF data
1	COM2	36	BIT 0-3: VNLR data BIT4-5: COR data
2	RCUTS	00	R CUT OFF (shift data of YUV)
3	GCUTS	00	G CUT OFF (shift data of YUV)
4	BCUTS	00	B CUT OFF (shift data of YUV)
5	GDRVS	00	G DRIVE (shift data of YUV)
6	BDRVS	00	B DRIVE (shift data of YUV)
7	NOIS	01	AFC GAIN SWITCHING ON/OFF
8	AUATT	58	Set 58
9	01 FLAG	03	Set 03

**MENU 14**

	MENU	int	Contents
0	WAITTIME	28	V-MUTE WHEN POWER ON V-MUTE Time. V-MUTE=16ms*data
1	CUR CEN	A2	Pull the act beginning position and the pass act be over positions
2	CUR STEP	03	Pull the minimum ambulation unit of screen of hour of act
3	PDSLL	03	screen saver writing is left to carry the adjustment of the position
4	PDSLRL	E1	screen saver writing is right to carry the adjustment of the position
5	PDSLTL	25	adjustment of the screen saver writing top end position
6	PDSLBL	88	screen saver writing descend carry the adjustment of the position
7	PDSIZE	00	LOGO Size
8	PDCOLOR	07	LOGO color
9	PDPOS	03	LOGO Position

**MENU 15**

	MENU	int	Contents
0	PDMICPOS	07	LOGO position adjust
1	RNP	1E	RNP Range
2	OSDF	65	OSD Clock frequency
3	OSDA	11	OSD position
4	OSDM	22	MENU position
5	OSDMA	22	Adjust choose position
6	CLTSE	48	CLT-SECAM
7	CLVSE	47	CLV-SECAM

## 8821AV/TV out (pin56) Explain

MODE	FLG1->bit0	TV	AV1	AV2	DVD
8821 Mono	1	-	0V	5V	0V
8821 Stereo	0	0V	Hi-Z	5V	Hi-Z

EEPROM address for auto white balance adjustment equipment :



	EEPROM addr.	TMPA8821 addr.	Range
R-CUT	22H	08H	00-FFH
G-CUT	23H	09H	00-FFH
B-CUT	24H	0AH	00-FFH
G-DRIVE	25H	0BH	00-7FH
B-DRIVE	26H	0CH	00-7FH

TMPA8821-5UD2 IIC device address: 088H (136)

EEPROM IIC device address : 0A0H (160)

**Note:**

Choose TA1304N.did not surround a function, need to close to surround a menu, adapt in the TMPA8821

Attach: The background color of the relevant factory data item adjusts the elucidation:

CAL BOX	Calendar box color
MENU UP BOX	Menu up box color
MENU DOWN BOX	Menu down box color
BAR BOX	Bar box color
GAME BOX	Game box color
TINT BOX	tint box color
FONT BOX	Font box color
SYS BOX	System box color

color check against 0000 Black

0001	Blue
0010	Green
0011	Blue green
0100	Red
0101	Carmine
0110	Yellow
0111	White
1000	Translucent black
1001	Translucent blue
1010	Translucent green
1011	Translucent and blue green
1100	Translucent red
1101	Translucent carmine
1110	Translucent yellow
1111	Gray

For example: CAL BOX Set 3AH Two background colors are blue and greens and translucent green

**factory of TMP88215UD2 adjusts to try the method**

Because TMPA8821 total line structure of the adoption IIC, the factory adjust to try the work and can complete through the appropriation remote control, the customer remote control realization adjusts to try the function

1.Enter the operation method of the factory mode



8821 have two kinds of methods into the factory mode:

Use the factory appropriation remote control. Press the factory appropriation remote control up enter to adjust to try the S( the in common use item adjusts to try) mode towards should adjust the key of the item, can immediately.

Use the common customer remote control, have to press CALENDAR, DSP and BAR keys into the mode of M in proper orderly in aly;( this mode has no signal not to shut down automatically, use ding for the production line television)Have to press BAR, DSP, SLEEP into a menu( press BAR key to stop the Vertical at this time) of factory in proper orderly in aly, press on this foundation'8' the key enters the white balance to adjust to try the menu( press BAR key to stop the Vertical at this time), press'2'+ '3' the key can immediately enter to adjust to try a menu all( SLEEP: Just turn over), press DSP key to withdraw a menu of factory;

Press down the volume" — " key of the television continue the companion sound SET 0,.Press a" DISP" on remote control key again, the screen appears the factory mode menu.

Carry on the options with the channel "+/-" key, carry on the adjustment with the volume "+/-" key.

Mode of D inside include all IIC total line adjustment data, please turn over the page to pursue an adjustment.

## 2. Withdraw the method of the factory mode

Press DISP key, power supply or control from a distance to close the television, withdraw the factory mode.

Under the factory mode, press the AV/ TV key, can circulate to choose the internal signal of IC to output the mode, the inner part adjusts to try the signal to is divided into the PAL and make type of NTSC, total 16 kinds of inner parses adjust to try the signal

## 3. Adjust to try the method

In various adjustment menus," P+"," P-" key used for the parameter item that makes selection the desire adjustment," V+"," V-" key used for the size of the enactment parameter.

## **TMPA8821 of LOGO can edit the function:**

Can carry on the adjustment for the size, color, position, can edit two line

Function elucidation: Grow to enter the LOGO editor appearance by four seconds of BAR (-/- key), the appearance divides at this time two kinds of on is an editor of LOGO: This appearance descend press V+, the V- key use come or so move, P+ the key withdraws the whole editor, the P- key is invalid, press numerical 1~9 importation character list, 0 lose the blank space;

Two is a parameter to adjust( include the size, color, position) to press MENU key to cut over the second appearance, use the V+, V- cut over the different appearance parameter, use the P+, the value of the parameter of P- adjustment; Withdraw the editor of LOGO, only have to press P once in the appearance+ the key withdraw. Regulate the factory item is of PDMICPOS can with tiny adjust the LOGO position