ST-NXP Wireless

IMPORTANT NOTICE

Dear customer,

As from August 2nd 2008, the wireless operations of STMicroelectronics have moved to a new company, ST-NXP Wireless.

As a result, the following changes are applicable to the attached document.

- **Company name - STMicroelectronics NV** is replaced with **ST-NXP Wireless**.
- **Copyright** - the copyright notice at the bottom of the last page “© STMicroelectronics 200x - All rights reserved”, shall now read: “© ST-NXP Wireless 200x - All rights reserved”.
- **Web site** - <http://www.st.com> is replaced with <http://www.stnwireless.com>
- **Contact information** - the list of sales offices is found at <http://www.stnwireless.com> under Contacts.

If you have any questions related to the document, please contact our nearest sales office. Thank you for your cooperation and understanding.

ST-NXP Wireless

Mobile video DENC

Features

- Two analog outputs (10 bits DAC) with:
 - CVBS (Composite) output or Y/C (S-VHS)
 - NTSC-J, M & 4.43 & PAL-BDGHI, N, Nc, M support
 - 35 mA current driver
- 8-bit digital interface input supporting both embedded and external synchro
 - CCIR 601 / YCbCr 4:2:2 format
 - CCIR 656: 27 Mhz pixel input clock
- Latest Macrovision (7.1.L1) (STw8019 only)
- 2-wire serial MPU interface (I2C compatible)
- Master and slave modes
- TV / VCR plug insertion detection
- Supply voltages
 - 2.8V/3.3V analog
 - 1.8V/2.8V digital I/O
 - 1.2V/1.4V for core
- Power consumption
 - Sleep mode: 5 μ W
 - Standby mode: 150 μ W maximum
 - CVBS: 125 mW
 - Y/C: 245 mW
- Package
 - TFBGA 4x4x1.2 mm height, 0.5 mm pitch,
 - VFBGA 3x3x1 mm height, 0.4 mm pitch
- Full matrix: 7 x 7

Applications

- Mobile video Digital ENCOder (DENC)

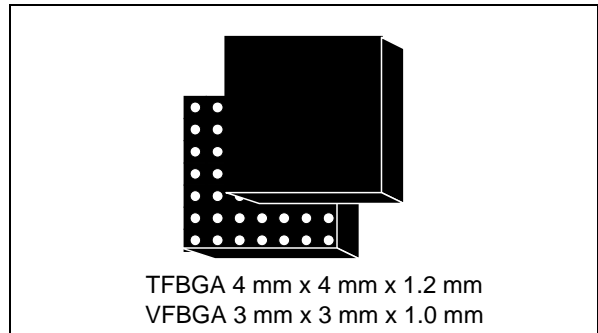
**Description**

STw80x9 is aimed at mobile video Digital ENCOder (DENC). This device converts digital video signals into high quality analog signal compliant with TV standards, it is able to encode interlaced (in all standards) and non-interlaced (in PAL and NTSC).

Featuring ultra low power consumption, it suits perfectly mobile appliances that interface occasionally with TV sets or VCRs. It is also the ideal companion for digital application processors such as ST's Nomadik family.

To minimize PCB space usage, STw80x9 features a high level of integration. STw80x9 drives directly the video input, CVBS of a TV set or the Y/C video input of a VCR through optional ESD protection devices.

The 27 MHz clock and the device power management are controlled through the digital processor interface [PORn, Suspend and 2-wire I2C compatible serial MPU]. This digital processor interface also controls the STw80x9 operating modes (off, sleep, standby and active).

Contents

1	Overview	6
2	Functional block diagram	7
3	Ball/pin information	8
4	Functional description	10
4.1	General	10
4.2	Master & slave modes	10
4.3	Auto test mode	10
4.4	Input demultiplexor	10
4.5	Video timing	11
4.6	Sub-carrier generation	15
4.7	Luminance encoding	15
4.8	Chrominance encoding	17
4.9	Composite video signal generation	19
4.10	Macrovision™ copy protection	19
4.11	TV/VCR plug insertion detection	19
4.12	DAC	19
4.13	Power management	19
4.13.1	Operating modes	20
4.13.2	Mode transition diagram	21
4.14	JTAG interface	22
5	Control registers	23
5.1	Register addresses	23
5.2	Description	25
5.2.1	DENC registers	25
5.2.2	Control & power management unit registers	45
6	Bus interface	47
6.1	2 wire serial MPU control interface (I2C compatible)	47
	7-bit address mode	47

	10 bits address mode	48
6.2	YcbCr bus	50
7	Electrical characteristics	51
7.1	Absolute maximum rating	51
7.2	Operating conditions	51
7.3	Electrical and timing characteristics	52
8	Application information	54
9	Color test pattern waveforms	55
10	Package mechanical data	59
10.1	TFBGA 49 balls	59
10.2	VFBGA 49 balls	61
11	Ordering information	63
12	Revision history	64

List of tables

Table 1.	Product name ball functions	8
Table 2.	NTSC and PAL timings	15
Table 3.	Register addresses	23
Table 4.	std1, std0	25
Table 5.	sync2, sync1, sync0	25
Table 6.	Register 1	26
Table 7.	valrst1 and valrst0 selection	28
Table 8.	syncin_ad[1:0]	29
Table 9.	syncout_ad[1:0]	29
Table 10.	jump, dec_ninc, free_jump	30
Table 11.	cfc[1:0]: color frequency control via CFC line	31
Table 12.	ph_rst_mode[1:0]: sub-carrier phase reset	32
Table 13.	dac2_mult[5:0]: multiplying factor on dac2_c digital signal	35
Table 14.	c_mult[3:0]: multiplying factor of C digital output	36
Table 15.	Chroma main_coef_[8:0]	38
Table 16.	main_del[3:0]	40
Table 17.	Luma_coef_[0:9]	41
Table 18.	dac12_conf	42
Table 19.	dac1_multi[5:0]	43
Table 20.	main_chr_del[3:0]	44
Table 21.	STw80x9 addresses	47
Table 22.	YcBCr data bus timing (Figure 22)	50
Table 23.	Absolute maximum ratings	51
Table 24.	Operating conditions	51
Table 25.	2 wire serial MPU control interface timing (Figure 20)	52
Table 26.	Digital I/O interface	52
Table 27.	Power consumption/R load = 37.5 ohm	53
Table 28.	DAC & Video output characteristics / Rload = 37.5 ohm – F = 27 MHz – Rext = 2.4 kohm	53
Table 29.	TFBGA 4x4x1.2 mm	59
Table 30.	VFBGA 3x3x1.0 mm - 49 balls - Pitch 0.4 ball 0.25	61
Table 31.	Order codes	63
Table 32.	Document revision history	64

List of figures

Figure 1.	Application diagram	6
Figure 2.	STw8009 block diagram	7
Figure 3.	STw8019 block diagram	7
Figure 4.	Ball layout	9
Figure 5.	Input data format (ITU-R656/D1 4:2:2)	12
Figure 6.	PAL-BDGI, PAL-N typical VBI waveform, interlaced mode (ITU-R625 line numbering)	13
Figure 7.	NTSC-M typical VBI waveforms, interlaced mode (SMTPE-524 line numbering)	13
Figure 8.	PAL-M typical VBI waveforms, interlaced mode (ITU-R/CCIR-525 line numbering)	14
Figure 9.	Horizontal blanked interval and active video timings	14
Figure 10.	Luma filtering	16
Figure 11.	Luma filtering with 3.58 MHz trap	16
Figure 12.	Luma filtering with 4.43 MHz trap	17
Figure 13.	1.1 MHz chroma filter	17
Figure 14.	1.3 MHz chroma filter	18
Figure 15.	1.6 MHz chroma filter	18
Figure 16.	1.9 MHz chroma filter	18
Figure 17.	Mode transition diagram	21
Figure 18.	2-wire serial MPU control interface format (I2C compatible) / 7-bit addresses	48
Figure 19.	2-wire serial MPU control interface format (I2C compatible) / 10-bit addresses	49
Figure 20.	2-wire serial MPU control interface timing	49
Figure 21.	YcbCr bus format	50
Figure 22.	Data bus timing	50
Figure 23.	Typical application schematic	54
Figure 24.	NTSC composite	55
Figure 25.	NTSC S-video	56
Figure 26.	PAL composite	57
Figure 27.	PAL S-video	58
Figure 28.	TFBGA 49 balls 4 x 4 x 1.2 mm body size	60
Figure 29.	VFBGA 49 balls 3 x 3 x 1.0 mm body size	62

1 Overview

STw80x9 is aimed at mobile video Digital ENCoder (DENC). This device converts digital video signals into high quality analog signal compliant with TV standards, it is able to encode interlaced (in all standards) and non-interlaced (in PAL and NTSC).

Featuring ultra low power consumption, it suits perfectly mobile appliances that interface occasionally with TV sets or VCRs. It is also the ideal companion for digital application processors such as ST's Nomadik family.

To minimize PCB space usage, the device features a high level of integration. The 35 mA high performance DAC allows direct drive of 37.5 Ω load.

STw80x9 drives directly the video input, CVBS of a TV set or the Y/C video input of a VCR through optional ESD protection devices. It is powered by three voltage supplies, 2.8V/3.3V, 1.8V/2.8V and 1.2V/1.4V (VccA, VI/O, Vdd).

The 27 MHz clock and the device power management are controlled through the digital processor interface [PORn, Suspend and 2-wire I2C compatible serial MPU]. This digital processor interface also controls the operating modes (off, sleep, standby and active).

Figure 1. Application diagram

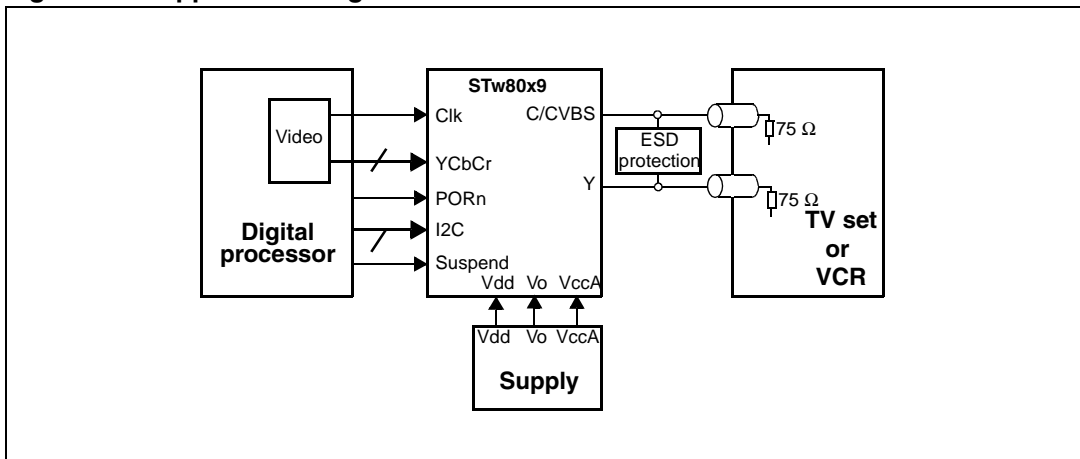

Naming convention

Unless clearly specified in the document, STw80x9 stands for both STw8009 and STw8019.

2 Functional block diagram

Figure 2. STw8009 block diagram

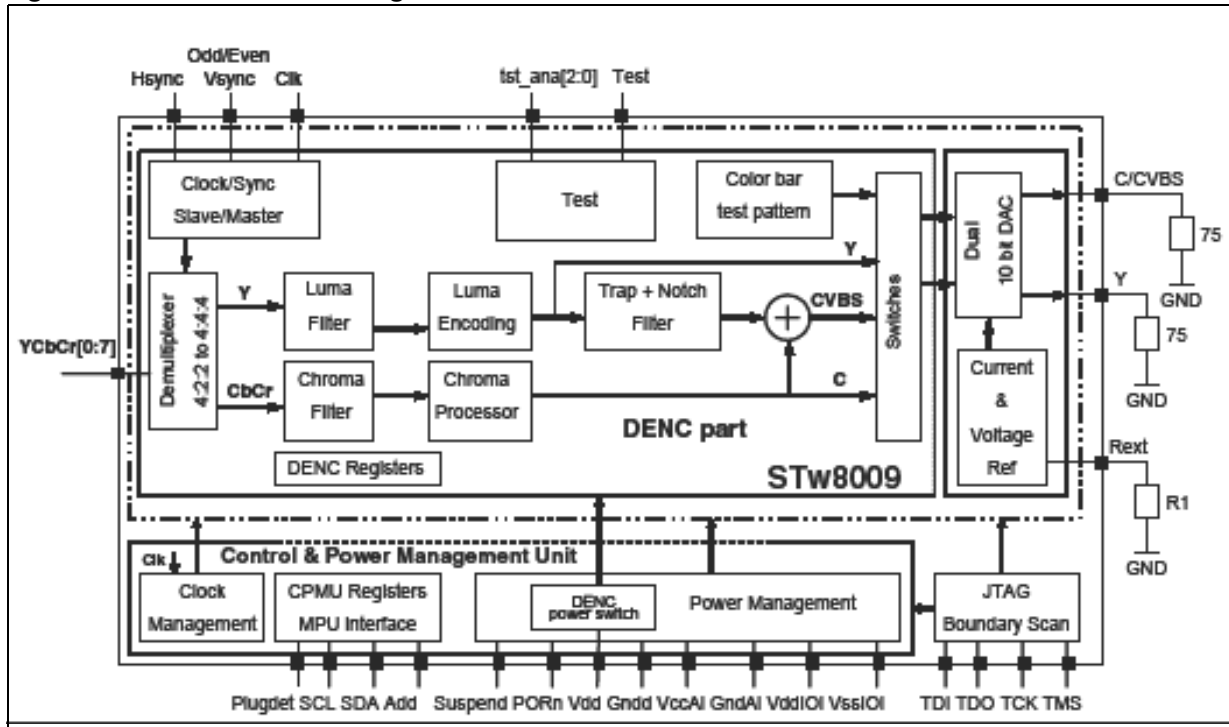
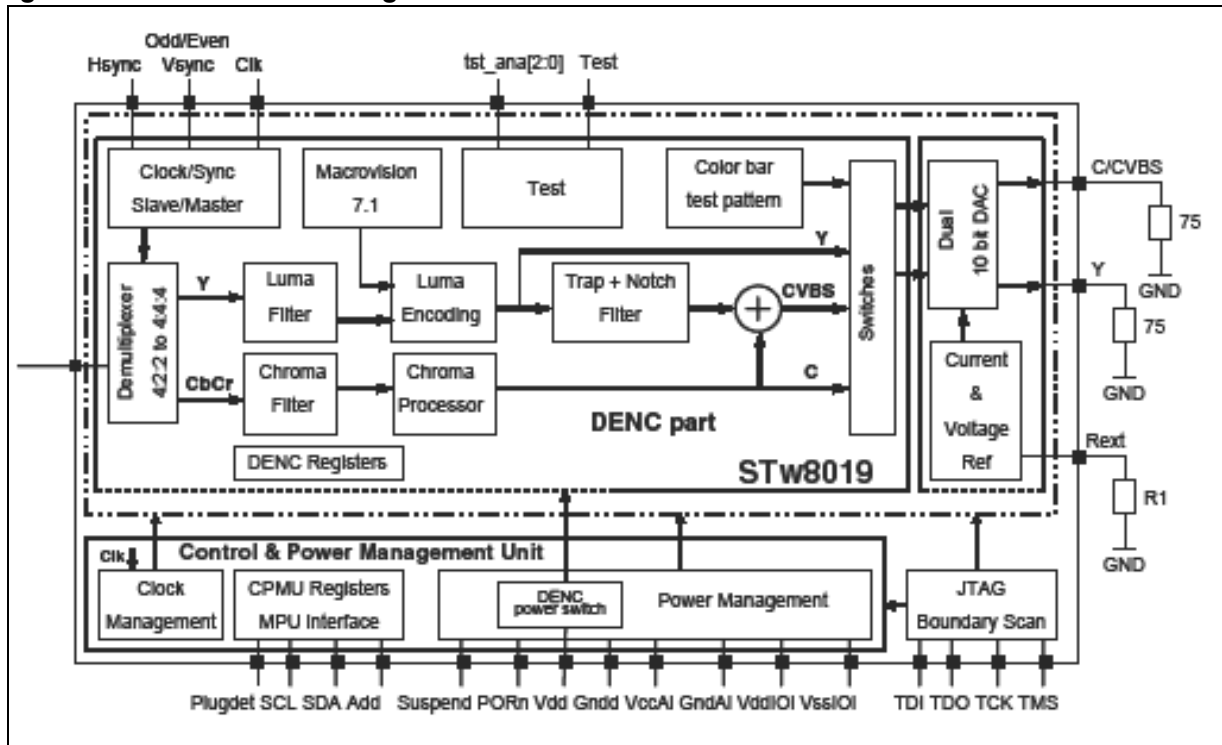

Figure 3. STw8019 block diagram



3 Ball/pin information

Table 1. Product name ball functions

Ball	Name	Type	Voltage	Description
E1	Vdd	Power	1.2V/1.4V	Digital core chip supply
D2	Gnnd	GND	0 V	Digital core chip ground
C1	VddIO1	Power	1.8V/2.8V	Digital I/O supply
D1	VssIO1	GND	0 V	Digital I/O ground
G4	VddIO2	Power	1.8V/2.8V	Digital I/O supply
E4	VssIO2	GND	0 V	Digital I/O ground
A3	VccA1	Power	2.8V/3.3V	DAC2 matrix analog power supply
A5	VccA2	Power	2.8V/3.3V	DAC1 matrix analog power supply
A7	VccA3	Power	2.8V/3.3V	2.8/3.3 V digital feature supply
B7	VccA4	Power	2.8V/3.3V	2.8 /3.3 V digital feature supply
B3	GND A1	GND	0 V	DAC2 ground
B5	GND A2	GND	0 V	DAC1 ground
C5	GND A3	GND	0 V	2.8 /3.3 V digital feature ground
B4	GND A4	GND	0 V	Rext ground connection
B6	GND A5	GND	0 V	Analog ground
A4	Rext	Analog		DAC current reference setting
G2	CLK	Digital Input	1.8V/2.8V	27 MHz master pixel clock (pixclk)
G7, G6, F7, F6, E7, E6, D7, D6	YCbCr[0:7]	Digital Input	1.8V/2.8V	Time multiplexed 4:2:2 luminance and chrominance data as defined in CCIR 601 and CCIR 656 (excepted for TTL input signals)
G5	Hsync	Digital I/O	1.8V/2.8V	Horizontal synchronization signal: - Input in slave mode, except when sync is extracted from YcbCr data - Output in master mode and when sync is extracted from YcbCr signal.
F5	Vsync Odd/Even	Digital I/O	1.8V/2.8V	Vertical Synchronization – Odd/Even signal: - Input in slave mode, except when sync is extracted from YcbCr data - Output in master mode and when sync is extracted from YcbCr signal.
F3	SDA	Digital I/O	1.8V/2.8V	2 wire serial MPU data line
G3	SCL	Digital Input	1.8V/2.8V	2 wire serial MPU clock
E3	Add	Digital input	1.8V/2.8V	Device address selection
C7	PORn	Digital input	1.8V/2.8V	Power On Reset (Active low)
F2	Suspend	Digital input	1.8V/2.8V	Suspend input

Table 1. Product name ball functions (continued)

Ball	Name	Type	Voltage	Description
A2	C/CVBS	Analog output		The output can be selected to be composite video or chroma signal for s-video.
A6	Y	Analog output		Luminance signal for s-video
B1	TDI	Digital input	1.8V/2.8V	JTAG test data in If not used, connected to GND
B2	TDO	Digital output	1.8V/2.8V	JTAG test data out If not used, left open
C2	TCK	Digital input	1.8V/2.8V	JTAG test clock If not used, connected to GND
C3	TMS	Digital input	1.8V/2.8V	JTAG test mode select If not used, connected to GND
D4	Test	Digital input	1.8V/2.8V	Put the device in test mode If not used, connected to GND
D3, F1, E2	tst_ana[0:2]	Digital input	1.8V/2.8V	DENC test If not used, connected to GND
F4	PlugDet	Digital input	1.8V/2.8V	TV / VCR plug connection detection / CMOS input

Figure 4. Ball layout

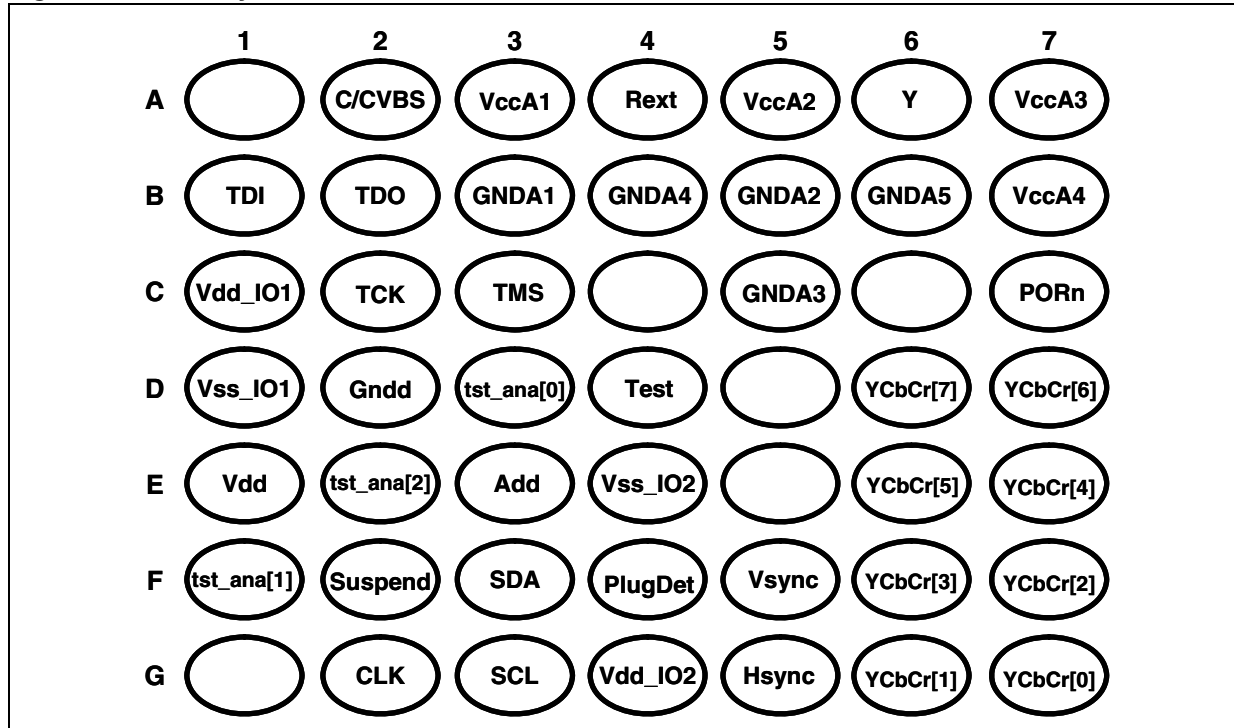

4 Functional description

4.1 General

STw80x9 operates either in master mode where it supplies all sync signal or in slave mode.

The digital input is an 8-bit bus carrying Y, Cb and Cr at 13.5 MHz. Input samples are latched in on the rising edge of the clock input signal.

STw80x9 is able to encode interlaced (in all standards) and non interlaced (in PAL and NTSC) video.

STw80x9 outputs interlaced or non-interlaced video in PAL-B,D,G,H,I,PAL-N,PAL-M or NTSC-M standards ("NTSC-4.43" is also possible).

The burst sequences are internally generated, subcarrier generation being performed numerically with the 27 MHz as reference. 4-frame bursts are generated for PAL or 2-frame bursts for NTSC. Rise and fall times of synchronization tips and burst envelope are internally controlled according to the relevant ITU_R and SMPTE recommendations.

4.2 Master & slave modes

In master mode, STw80x9 supplies Hsync and Odd/Even sync signals (with independently programmable polarities) to drive other blocks. STw80x9 starts encoding and counting clock cycles as soon as the master mode has been loaded into the control register (Reg 0). Configuration bits "Syncout_ad[1:0]" (Reg 4) allow to shift the relative position of the sync signals by up to 3 clock cycles to cope with any YcbCr phasing.

In slave modes, several modes are available, Odd/Even+Hsync based, Vsync+Hsync based, Odd/Even-only based, Vsync-only based or Sync-in-data based.

4.3 Auto test mode

An auto test mode is available, which causes STw80x9 to produce a color bar pattern, in the appropriate standard, independently from the video input.

4.4 Input demultiplexor

The incoming YcbCr 4:2:2 data are demultiplexed into chroma information stream, a "blue-difference" and a "red-difference", and a luma information stream. Incoming data bits are treated as blue, red or luma samples according to their relative position with respect to the sync signals. Brightness, Saturation and Contrast are then performed on demultiplexed data.

The ITU-R601 recommendation defines the black luma level as $Y=16_{dec}$ and the maximum white luma level as $Y=235_{dec}$. Similarly it defines 255 quantification levels for the color difference components (Cr, Cb) centered around 128. Accordingly, incoming YcbCr samples can be saturated. In this case STw80x9 provides a saturation limitation feature to avoid having heavily saturated signal before digital to analog conversion and to avoid generating a distorted signal at STw80x9 CVBS or Y/C outputs.

4.5 Video timing

The DENC outputs video in PAL-B,D,G,H,I, PAL-N, PAL-M or NTSC-J, M standards ('NTSC-4.43' is also possible).

The burst sequences are internally generated, subcarrier generation being performed numerically with PIX_CLK as reference. 4-frame bursts are generated for PAL or 2-frame bursts for NTSC. Rise and fall times of synchronization tips and burst envelope are internally controlled according to the relevant ITU-R and SMPTE recommendations.

Figure 5, 6, 7 and 8 depict typical VBI waveforms.

It is possible to allow encoding of incoming YCrCb data on those lines of the VBI that do not bear line sync pulses or pre/post-equalization pulses (*Figure 5, 6, 7 and 8*). This mode of operation is referred to as "partial blanking" and is the default set-up. It allows to keep in the encoded waveform any VBI data present in digitized form in the incoming YCrCb stream. Alternatively, the complete VBI may be fully blanked, so no incoming YCrCb data encoded on these lines.

The 'complete' VBI comprises of the following lines:

- for 525/60 systems (SMPTE line numbering convention): lines 1 to 19 and second half of line 263 to line 282
- for 625/50 systems (CCIR line numbering convention): second half of line 623 to line 22 and lines 311 to 335

The 'partial' VBI consists of:

- for 525/60 systems (SMPTE line numbering convention): lines 1 to 9 and second half of line 263 to line 272
- for 625/50 systems (CCIR line numbering convention): second half of line 623 to line 5 and lines 311 to 318

Full or partial blanking is controlled by configuration bit 'blkl' in configuration register 1'.

*Note: line 282 in 525/60/SMPTE systems is either fully blanked or fully active.
line 23 in 625/60/CCIR systems is always fully active.*

In an ITU-R656-compliant digital TV line, the active portion of the digital line is the portion included between the SAV (Start of Active Video) and EAV (End of Active Video) words. However, this digital active line starts somewhat earlier and may end slightly later than the active line usually defined by analog standards.

The DENC permits two approaches:

- Encodes the full digital line (720 pixels / 1440 clock cycles). In this case, the output waveform will reflect the full YCrCb stream included between SAV and EAV.
- Drops some YCrCb samples at the extremities of the digital line so that the encoded analog line fits within the 'analog' ITU-R/SMPTE specifications.

Selection between these two modes of operation is performed with bit 'aline' in configuration register 4.

In all cases, the transitions between horizontal blanking and active video are shaped to avoid too steep edges within the active video. Figure 11 on page 15 gives timings concerning the horizontal blanking interval and the active video interval.

Figure 5. Input data format (ITU-R656/D1 4:2:2)

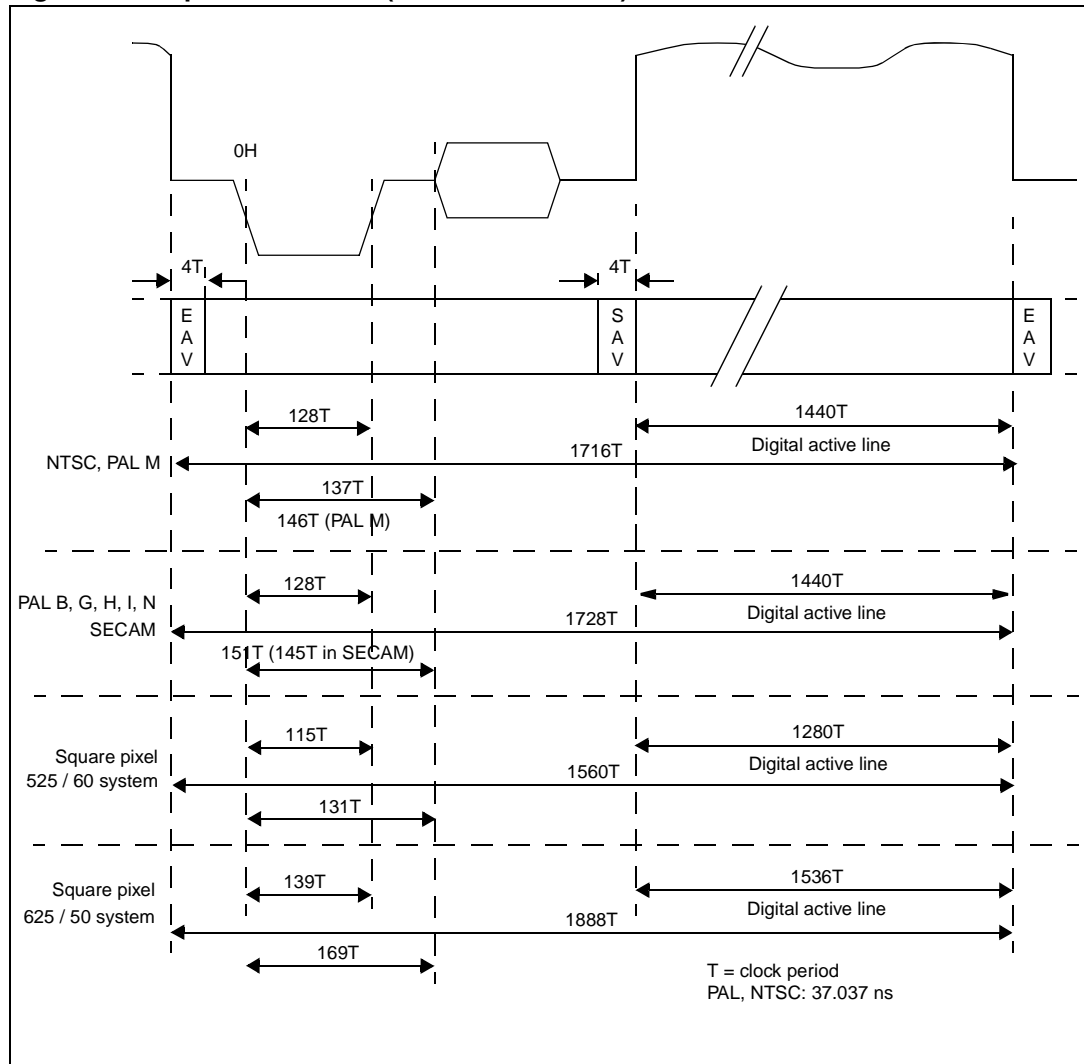

Note: The burst envelope shown here indicates the location from which the first subcarrier positive zero crossing is sought (with respect to the 0_H reference). The normal burst always starts with such a positive zero crossing.

Figure 6. PAL-BDGHI, PAL-N typical VBI waveform, interlaced mode (ITU-R625 line numbering)

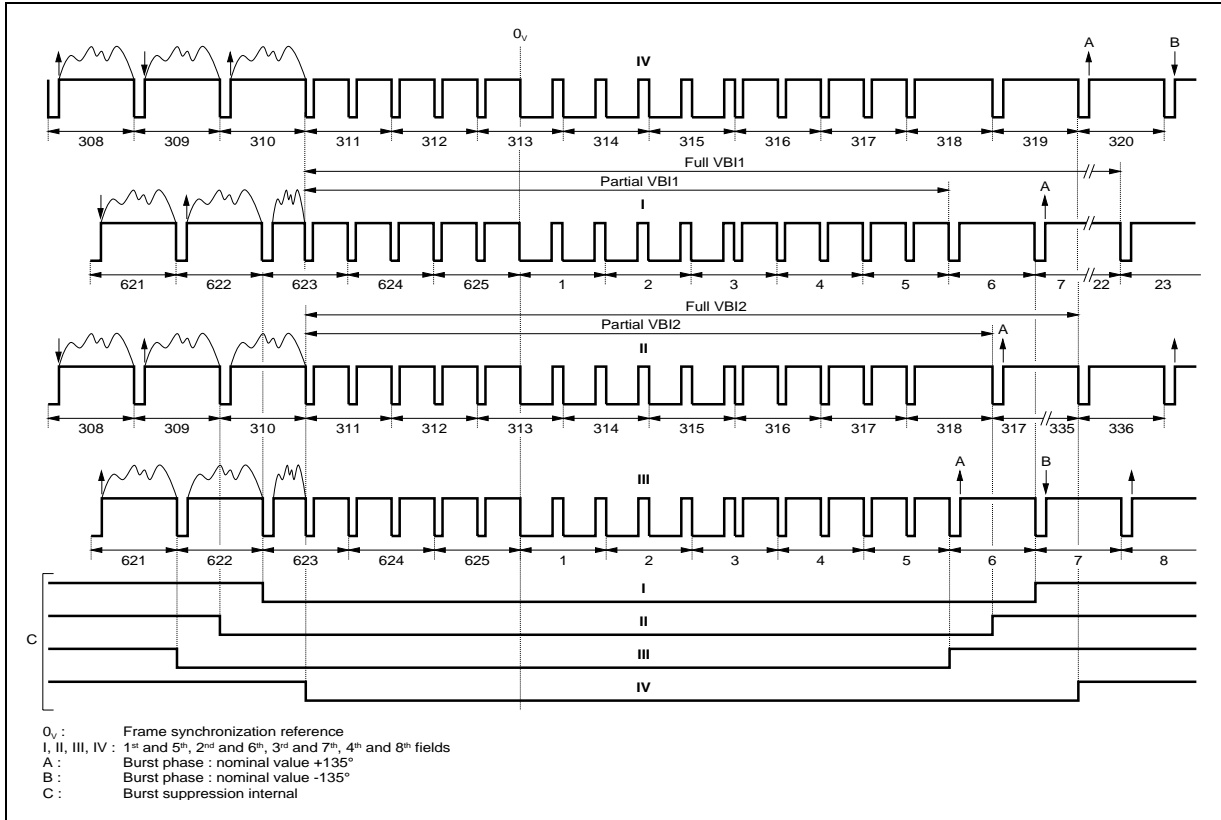

Figure 7. NTSC-M typical VBI waveforms, interlaced mode (SMTPE-524 line numbering)

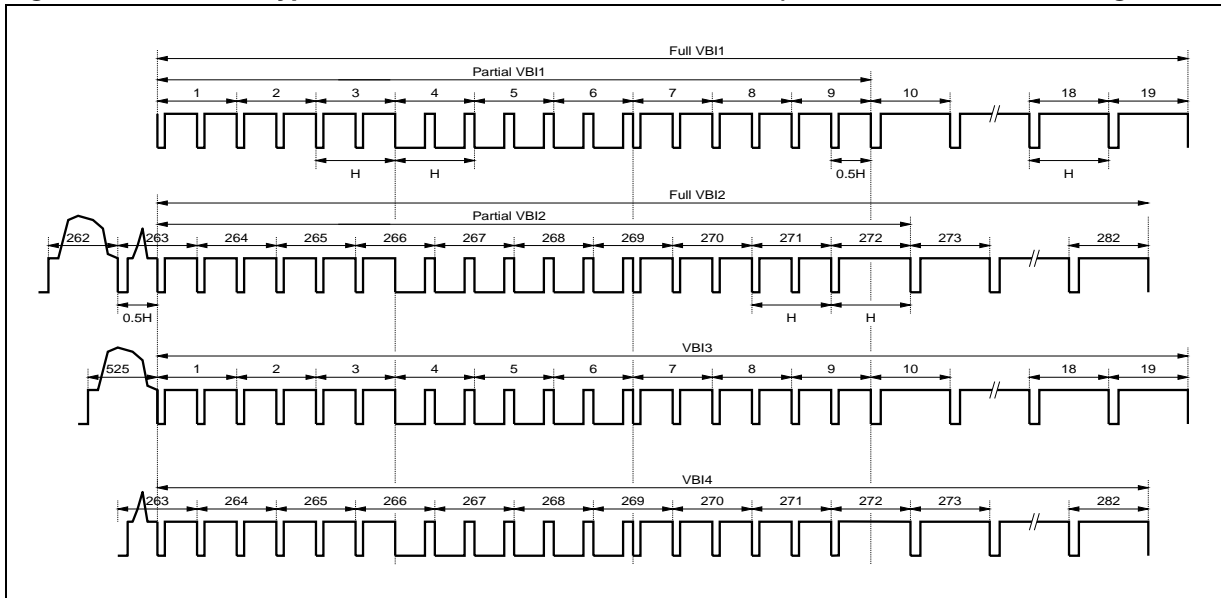

Figure 8. PAL-M typical VBI waveforms, interlaced mode (ITU-R/CCIR-525 line numbering)

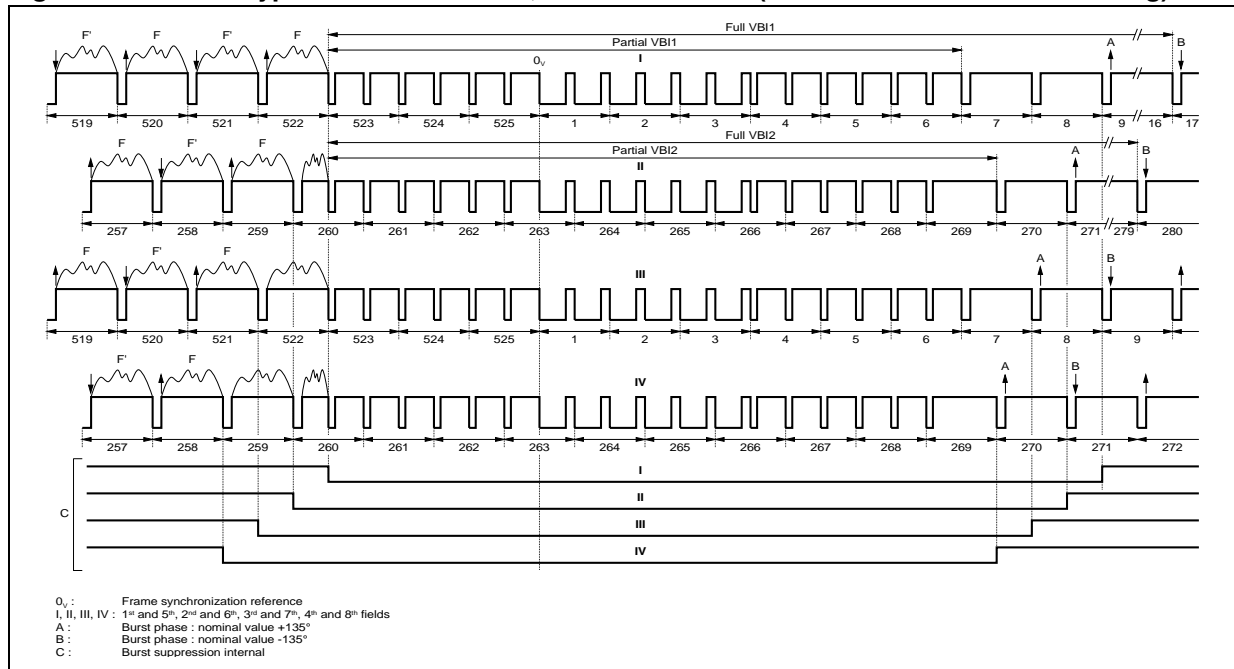

Figure 9. Horizontal blanked interval and active video timings

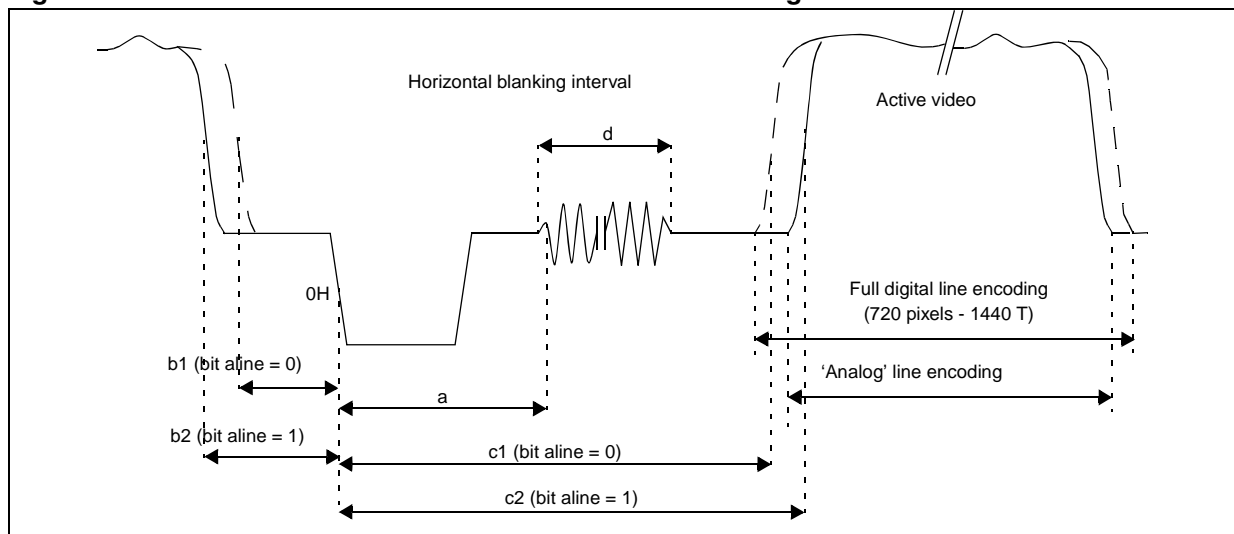

Table 2. NTSC and PAL timings

	NTSC-M	PAL-BDGHI	PAL-N	PAL-M
a ⁽¹⁾	5.38 μ s (even lines) 5.52 μ s (odd lines)	5.54 μ s (A-type) 5.66 μ s (B-type)	5.54 μ s (A-type) 5.66 μ s (B-type)	5.73 μ s (A-type) 5.87 μ s (B-type)
b1	1.56 μ s	1.3 μ s	1.3 μ s	1.56 μ s
b2	1.56 μ s	1.52 μ s	1.52 μ s	1.56 μ s
c1	8.8 μ s	9.6 μ s	9.6 μ s	8.8 μ s
c2	9.41 μ s	10.48 μ s	10.48 μ s	9.41 μ s
d	9 cycles of 3.58MHz	10 cycles of 4.43MHz	9 cycles of 3.58MHz	9 cycles of 3.58MHz

1. These are typical values. Actual values will depend on the static offset programmed for subcarrier generation

4.6 Sub-carrier generation

A Direct Digital Frequency Synthesizer (DDFS) generates the required color sub-carrier frequency using a 24-bit phase accumulator. Sub-carrier frequency is programmable with a 1.6 Hz step.

4.7 Luminance encoding

The luminance that is added to the chrominance to create the composite CVBS signal can be trap-filtered at 3.58 MHz (NTSC) or 4.43 MHz (PAL). This supports application oriented towards low-end TV sets which are subject to cross-color.

A 7.5 IRE pedestal can be programmed if needed with all standards. This allows in particular to encode Argentinian and non-Argentinian PAL-N, or Japanese NTSC.

A programmable delay can be inserted on the luminance path to offset any chroma/luma delay introduced by off-chip filtering.

STw80x9 output signals are IF modulated in NTSC M standard so that a sound notch filter is required. The notch filter which is on the Luma path is defined by a set of coefficients and is implemented in the STw80x9 as default values. The set is also programmable.

Figure 10. Luma filtering

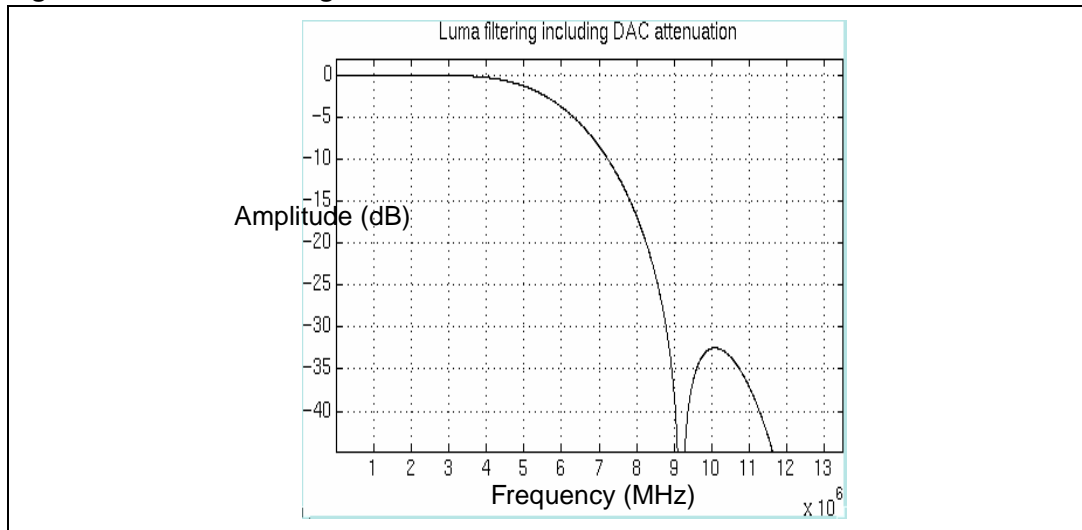

Figure 11. Luma filtering with 3.58 MHz trap

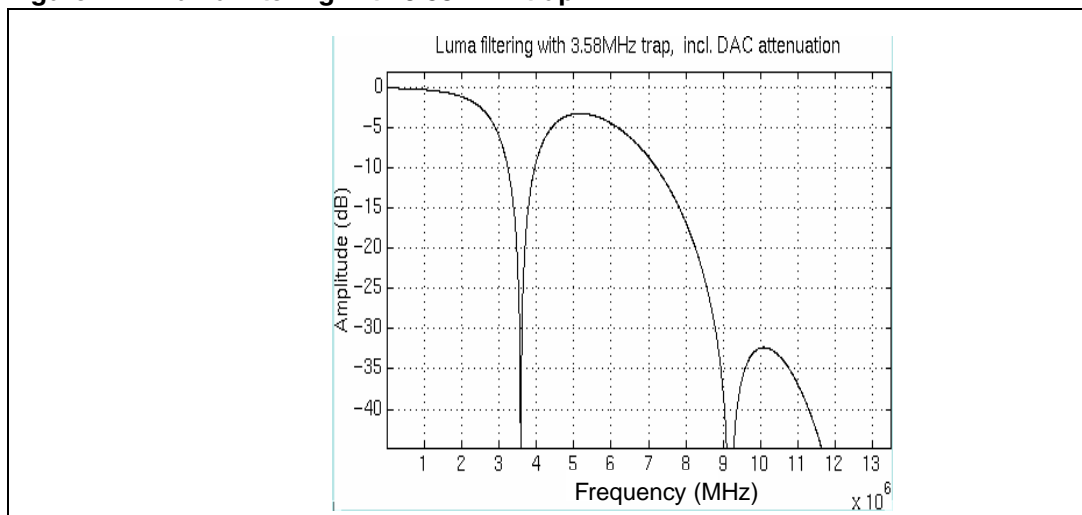
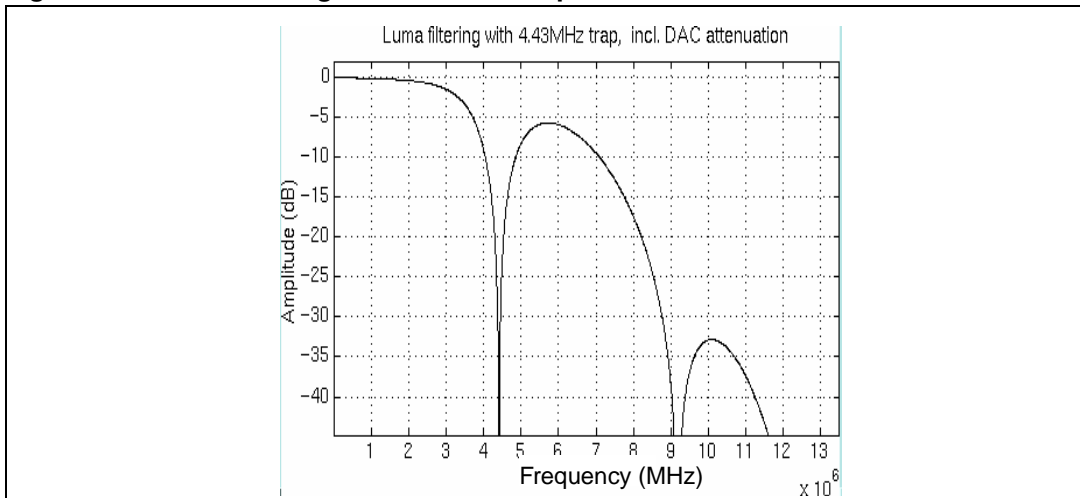

Figure 12. Luma filtering with 4.43 MHz trap



4.8 Chrominance encoding

Chroma components are computed from demultiplexed Cb, Cr samples. Before modulating the subcarrier, the chroma components are band-limited and interpolated at pixel clock rate. A set of 4 different filters is available for chroma filtering to suit a wide variety of applications in the different standards and filters recommended by ITU-R 624-4 and SMPTE170-M. The available -3dB bandwidths are 1.1, 1.3, 1.6 and 1.9 MHz.

Narrow bandwidths are useful against cross-luminance artifacts while wide bandwidths allow to keep higher chroma contents.

Figure 13. 1.1 MHz chroma filter

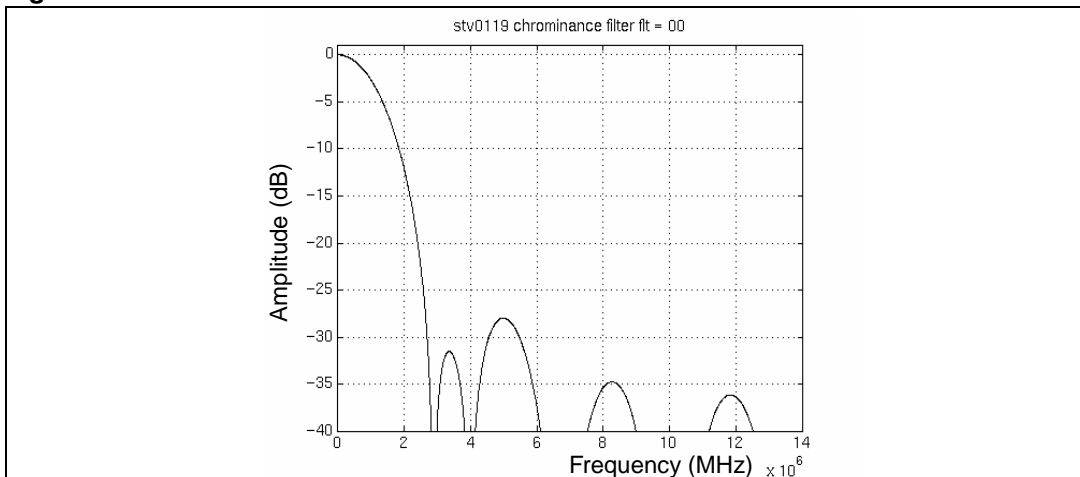

Figure 14. 1.3 MHz chroma filter

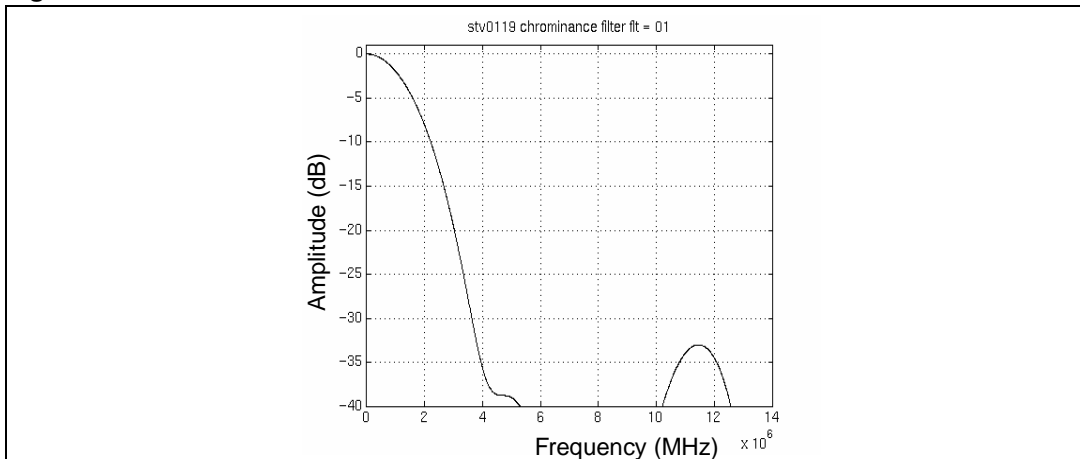

Figure 15. 1.6 MHz chroma filter

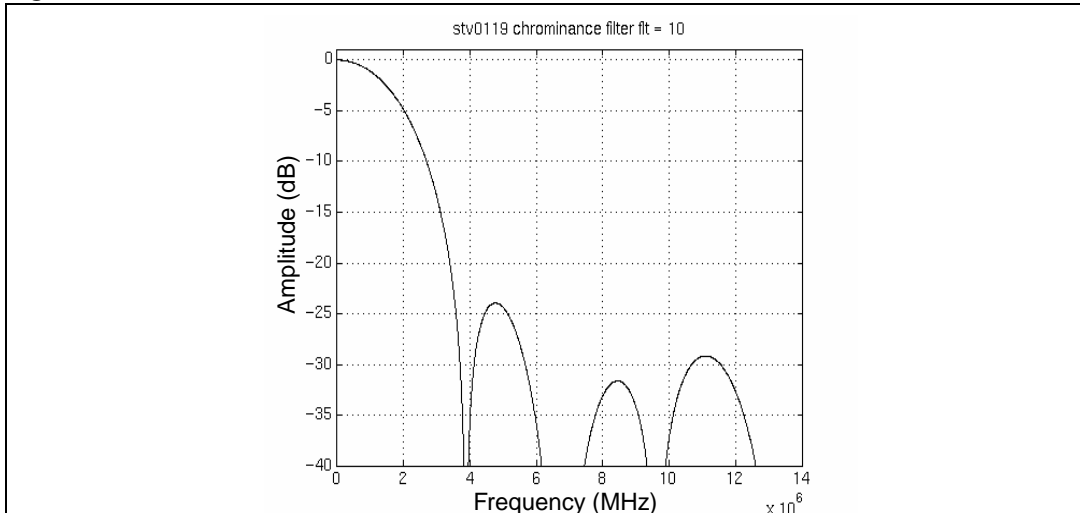
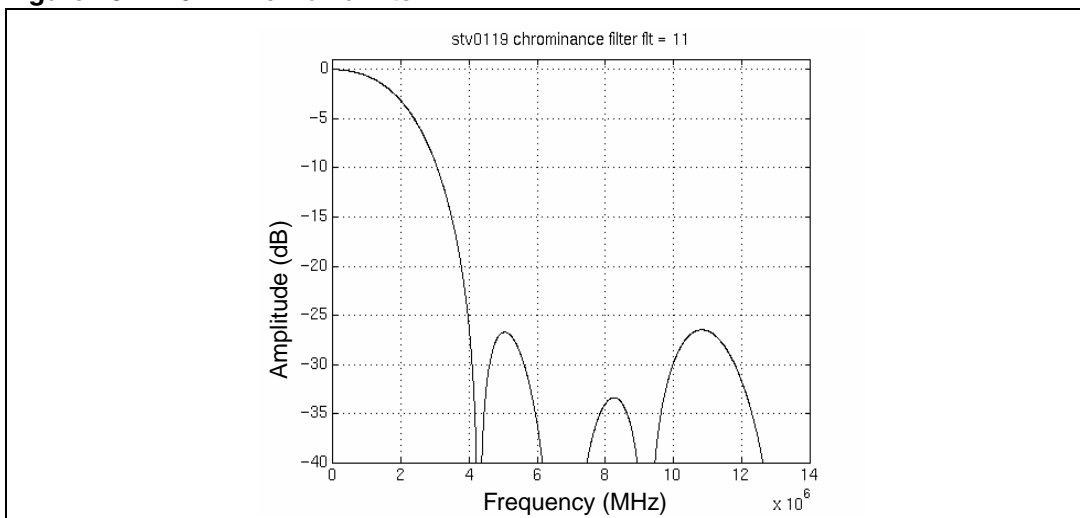

Figure 16. 1.9 MHz chroma filter



4.9 Composite video signal generation

The composite video signal is created by adding the luminance and the chrominance components. A saturation function is included in the adder to avoid overflow errors.

4.10 Macrovision™ copy protection

The chrominance luminance and composite video signals and RGB video signals can be altered according to the Macrovision™ copy protection Revision 7.01 and Revision 6.1.

This process is controlled via the I²C bus. A programming document is available to those customers who have executed a license or a non-disclosure agreement with Macrovision Corporation.

For all relevant information or document please contact:

Macrovision Corporation:
2830 De La Cruz Blvd.
Santa Clara, CALIFORNIA 95050
USA
www.macrovision.com

4.11 TV/VCR plug insertion detection

Plugdet ball is used to detect the connection of a TV or a VCR. The host can read the status in a dedicated register in standby and active modes.

4.12 DAC

STw80x9 outputs generate Composite video signal on one output or Y/C video signals on two outputs.

Two embedded 10-bit DACs allow the STw80x9 to directly drive 37.5 Ohms loads on each output.

4.13 Power management

Power management includes power supplies, reset signals, clock gating and a set of dedicated pins and registers. Power management is used to set the STw80x9 in different operating modes.

4.13.1 Operating modes

STw80x9 can be in the following operating modes.

- OFF
 - 1.2V/1.4V, 1.8V/2.8V, 2.8V/3.3V are not present.
 - All values from STw80x9 registers are lost.
- Sleep
 - 1.2V/1.4V, 1.8V/2.8V, 2.8V/3.3V are present.
 - The suspend signal is active.
 - The DACs are in their minimum power consumption mode.
 - All values from the STw80x9 registers are lost.
 - The 27 MHz pixel clock must be activated
- Standby
 - All power supplies are present: 1.2V/1.4V, 1.8V/2.8V, 2.8V/3.3V.
 - The 27 MHz pixel clock must be activated.
 - The suspend signal is inactive.
 - STw80x9 is set in standby mode by programming the Control and power Management Unit registers (Reg 128 to 132) through the 2 wire serial MPU interface. STw80x9 saves the register values.
 - The other registers (Reg 00 to 109) are not accessible in this mode.
 - The DACs are in their minimum power consumption mode.
 - This mode is a low power state that enables a fast switching to active mode.
- Active
 - All power supplies are present: 1.2V/1.4V, 1.8V/2.8V, 2.8V/3.3V.
 - STw80x9 receives the 27 MHz pixel clock.
 - The suspend signal is inactive.
 - STw80x9 is placed in active mode by programming the control and power management unit registers (Reg 128 to 132), through the 2 wire serial MPU interface. STw80x9 saves the register values.
 - The 27 MHz pixel clock is distributed in all STw80x9.

The DACs are supplied by the 2.8 /3.3 V and can be individually activated or deactivated. For example only one DAC in CVBS output and both DACs in Y/C output.

4.13.2 Mode transition diagram

The following mode transition diagram shows the main possible transitions between the modes and the actions.

Figure 17. Mode transition diagram

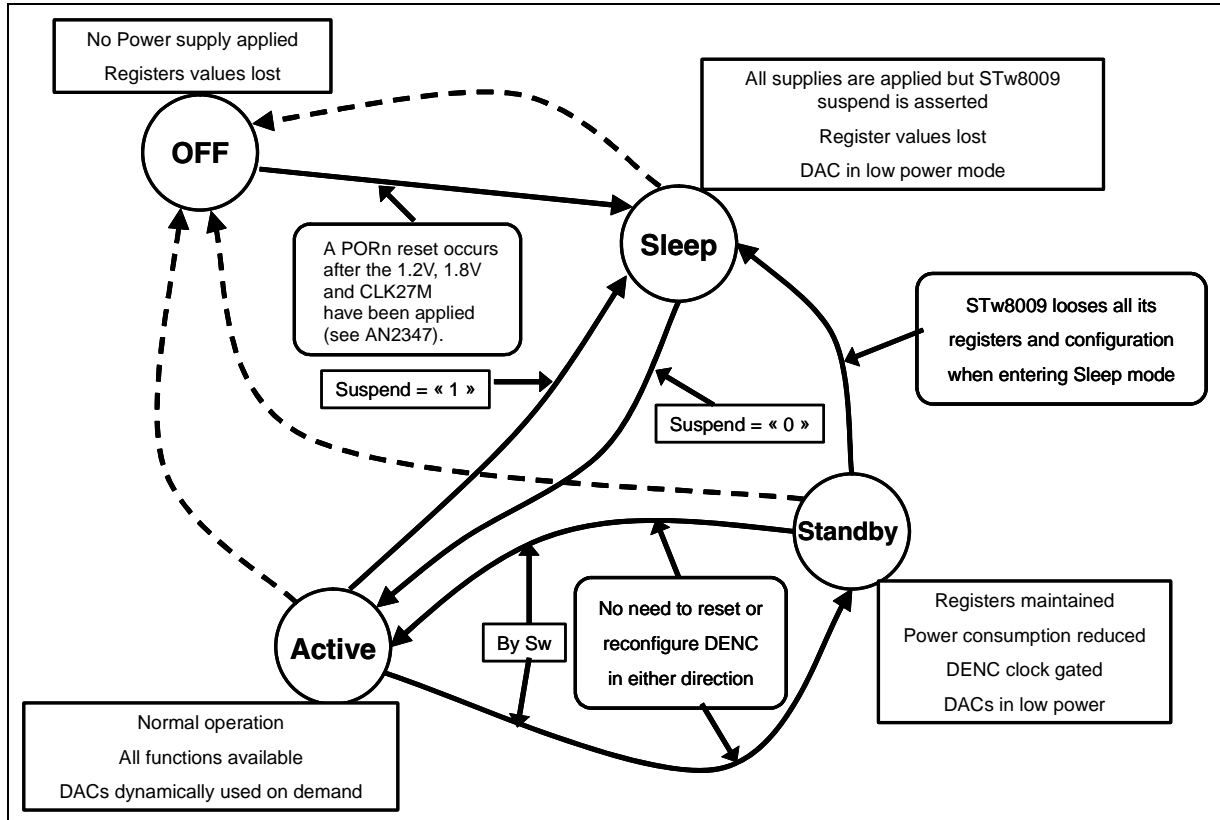

Transitions to OFF mode

The possible transitions are indicated in *Figure 17: Mode transition diagram* in dotted lines. No internal data needs to be saved and the STw80x9 can be turned OFF from any mode. The only restriction is to comply with the power supply rules described here after.

Transition from OFF mode to Sleep mode then to Active mode

Power up must be done by starting from OFF to Sleep mode and then from Sleep to Active mode. Sleep to Standby is not possible.

The host sends the order for the STw80x9 to switch from Sleep to Active mode by releasing Suspend ball. The device then generates a reset sequence to the DENC part.

Transition from Active mode to Sleep mode

In Sleep mode, DENC is not powered on. When Suspend signal changes from « 0 » to « 1 », the device goes from Active to Sleep mode and an internal Reset signal is generated by the Control Power Unit management to the DENC part. This signal has a 6 pixclk duration (pixclk = 27 MHz).

Transition between Standby and Active modes

Transitions between these two modes are applied by software configuration through I2C interface.

Supply management

At power up, supplies must be applied according to the following sequence:

VddIO1, VddIO2 (1.8V/2.8V) then,
Vdd (1.2V/1.4V) then,
VccA1, VccA2, VccA3, VccA4 (2.8V/3.3V)

and removed according to the following sequence:

VccA1, VccA2, VccA3, VccA4 (2.8V/3.3V) then,
Vdd (1.2V/1.4V) then,
VddIO1, VddIO2 (1.8V/2.8V)

4.14 JTAG interface

To ease the integration of STw80x9 in its system application, a JTAG interface is available.

5 Control registers

5.1 Register addresses

Table 3. Register addresses

Name	Type	N°	Bit7	Bit6	Bit5	Bit4	Bit3	Bit2	Bit1	Bit0
DENC registers										
configuration0	R/W	00	std1	std0	sync2	sync1	sync0	polh	polv	freerun
configuration1	R/W	01	blkli	flt1	flt0	sync_ok	coki	setup_main	[0]	[0]
configuration2	R/W	02	nintrl	enrst	bursten	xxx	selrst	rstosc_buf	valrst1	valrst0
configuration3	R/W	03	main_entrapp	trap_4.43	[0]	[0]	main_del_en	val_422_ck_mux	xxx	[0]
configuration4	R/W	04	syncin_ad1	syncin_ad0	syncout_ad1	syncout_ad0	aline	hue_en	xxx	xxx
configuration5	R/W	05	selrst_inc	bkdac2	bkdac1	[0]	[0]	[0]	[0]	dacinv
configuration6	R/W	06	softreset	jump	dec_ninc	free_jump	cfc1	cfc0	[0]	maxdyn
configuration7	R/W	07	[0]	[0]	[0]	xxx	[0]	bypass_sync_corr	[0]	[0]
configuration8	R/W	08	ph_rst_mode1	ph_rst_mode0	xxx	val_422_mux	blk_all	xxx	xxx	xxx
Status	R	09	hok	atfr			fldct2	flsct1	fldct0	jump
increment_dfs	R/W	10	d23	d22	d21	d20	d19	d18	d17	d16
increment_dfs	R/W	11	d15	d14	d13	d12	d11	d10	d9	d8
increment_dfs	R/W	12	d7	d6	d5	d4	d3	d2	d1	d0
phase_dfs	R/W	13	xxx	xxx	xxx	xxx	xxx	xxx	o23	o22
phase_dfs	R/W	14	o21	o20	o19	o18	o17	o16	o15	o14
dac2mult	R/W	17	dac2_mult5	dac2_mult4	dac2_mult3	dac2_mult2	dac2_mult1	dac2_mult0	[1]	[0]
reserved	R/W	20	xxx	xxx	xxx	xxx	xxx	xxx	xxx	xxx
line_reg	R/W	21	ltarg8	ltarg7	ltarg6	ltarg5	ltarg4	ltarg3	ltarg2	ltarg1
line_reg	R/W	22	ltarg0	lref8	lref7	lref6	lref5	lref4	lref3	lref2
line_reg	R/W	23	lref1	lref0	-	-	-	-	-	-
Reserved	R	24	-	-	-	-	-	-	-	-
reserved	xxx	45	xxx	xxx	xxx	xxx	xxx	xxx	xxx	xxx
...
reserved	xxx	63	xxx	xxx	xxx	xxx	xxx	xxx	xxx	xxx
c_mult & ttx	R/W	65	c_mult3	c_mult2	c_mult1	c_mult0	[0]	xxx	[0]	bcs_en_main
Brightness	R/W	69	b7	b6	b5	b4	b3	b2	b1	b0
Contrast	R/W	70	c7	c6	c5	c4	c3	c2	c1	c0
Saturation	R/W	71	s7	s6	s5	s4	s3	s2	s1	s0
Chroma_coef_0	R/W	72	flt_s	plg_div1	plg_div0	c0(4)	c0(3)	c0(2)	c0(1)	c0(0)
Chroma_coef_1	R/W	73	xxx	c8(8)	c1(5)	c1(4)	c1(3)	c1(2)	c1(1)	c1(0)
Chroma_coef_2	R/W	74	xxx	c2(6)	c2(5)	c2(4)	c2(3)	c2(2)	c2(1)	c2(0)

Table 3. Register addresses

Name	Type	N°	Bit7	Bit6	Bit5	Bit4	Bit3	Bit2	Bit1	Bit0
Chroma_coef_3	R/W	75	xxx	c3(6)	c3(5)	c3(4)	c3(3)	c3(2)	c3(1)	c3(0)
Chroma_coef_4	R/W	76	c4(7)	c4(6)	c4(5)	c4(4)	c4(3)	c4(2)	c4(1)	c4(0)
Chroma_coef_5	R/W	77	c5(7)	c5(6)	c5(5)	c5(4)	c5(3)	c5(2)	c5(1)	c5(0)
Chroma_coef_6	R/W	78	c6(7)	c6(6)	c6(5)	c6(4)	c6(3)	c6(2)	c6(1)	c6(0)
Chroma_coef_7	R/W	79	c7(7)	c7(6)	c7(5)	c7(4)	c7(3)	c7(2)	c7(1)	c7(0)
Chroma_coef_8	R/W	80	c8(7)	c8(6)	c8(5)	c8(4)	c8(3)	c8(2)	c8(1)	c8(0)
configuration9	R/W	81	main_del3	main_del2	main_del1	main_del0	xxx	plg_div_y1	plg_div_y0	flt_ys
luma_coef_0	R/W	82	xxx	xxx	l8(8)	l0(4)	l0(3)	l0(2)	l0(1)	l0(0)
luma_coef_1	R/W	83	l9(9)	l9(8)	l1(5)	l1(4)	l1(3)	l1(2)	l1(1)	l1(0)
luma_coef_2	R/W	84	l6(8)	l2(6)	l2(5)	l2(4)	l2(3)	l2(2)	l2(1)	l2(0)
luma_coef_3	R/W	85	l7(8)	l3(6)	l3(5)	l3(4)	l3(3)	l3(2)	l3(1)	l3(0)
luma_coef_4	R/W	86	l4(7)	l4(6)	l4(5)	l4(4)	l4(3)	l4(2)	l4(1)	l4(0)
luma_coef_5	R/W	87	l5(7)	l5(6)	l5(5)	l5(4)	l5(3)	l5(2)	l5(1)	l5(0)
luma_coef_6	R/W	88	l6(7)	l6(6)	l6(5)	l6(4)	l6(3)	l6(2)	l6(1)	l6(0)
luma_coef_7	R/W	89	l7(7)	l7(6)	l7(5)	l7(4)	l7(3)	l7(2)	l7(1)	l7(0)
luma_coef_8	R/W	90	l8(7)	l8(6)	l8(5)	l8(4)	l8(3)	l8(2)	l8(1)	l8(0)
luma_coef_9	R/W	91	l9(7)	l9(6)	l9(5)	l9(4)	l9(3)	l9(2)	l9(1)	l9(0)
configuration11	R/W	93	[0]	[0]	[1]	[0]	xxx	main_if_del	xxx	xxx
configuration12	R/W	94	[0]	[0]	[0]	[0]	[0]	ennotch	[0]	xxx
configuration13	R/W	95	[0]	[0]	dac12_conf	[0]	[0]	[0]	[0]	[1]
hue_control	R/W	105	hue_cont (7)	hue_cont (6)	hue_cont (5)	hue_cont (4)	hue_cont (3)	hue_cont (2)	hue_cont (1)	hue_cont(0)
dac1_mult	R/W	106	-	-	dac1_mult5	dac1_mult4	dac1_mult3	dac1_mult2	dac1_mult1	dac1_mult0
Chroma_delay	R/W	108	[0]	[0]	[0]	[0]	main_chr_ del3	main_chr_ del2	main_chr_ del1	main_chr_ del 0
Chroma_delay_ en	R/W	109	-	-	-	-	-	[0]	[0]	main_chr_ del_ en
Control & power management unit registers										
Cpmu_conf0	R/W	128	-	-	-	-	-	-	-	standby
Cpmu_conf1	R/W	129	-	-	-	-	-	-	-	cpmuswrst
dac2ctrl	R/W	130	-	-	-	-	-	poff1	notzero-d1	pedestalOnd 1
dac1ctrl	R/W	131	-	-	-	-	-	poff2	notzerod2	pedestalOnd 2
Plugdet	R	132	-	-	-	-	-	-	-	loadD
l_test0	R/W	133	-	-	-	-	-	-	-	-

5.2 Description

(*) = DEFAULT mode when not_reset pin is active (LOW level)

Caution: All binary values quoted should be understood as MSB.....LSB

5.2.1 DENC registers

REGISTER 0 configuration0 Address: 0x0000 Type: R/W

content	std1	std0	sync2	sync1	sync0	polh	polv	freerun
default	1	0	0	1	0	0	1	0

Table 4. std1, std0

	std1	std0	Standard selected
	0	0	PAL BDGHI
	0	1	PAL N (see bit set-up)
(*)	1	0	NTSC M ⁽¹⁾
	1	1	PAL M

1. Standard on hardware reset is NTSC; any standard modification selects automatically the right parameters for correct subcarrier generation.

Table 5. sync2, sync1, sync0

	sync2	sync1	sync0	Configuration
	0	0	0	ODDEV-only based SLAVE mode (frame locked)
	0	0	1	'F' based SLAVE mode (frame locked)
(*)	0	1	0	ODDEV+HSYNC based SLAVE mode (line locked)
	1	0	0	VSYNC-only based SLAVE mode (frame locked) ⁽¹⁾
	1	0	1	VSYNC+HSYNC based SLAVE mode (line locked)
	1	1	0	MASTER mode
	1	1	1	AUTOTEST mode (colour bar pattern)

1. In VSYNC-only based slave mode (sync[2:0]="100"), HSYNC is nevertheless needed as an input.

polh: synchro: active edge of HSYNC selection (when input) or polarity of HSYNC (when output)

(*) 0 = HSYNC is a negative pulse (128 Tpix_clk wide) or falling edge is active

1 = HSYNC is a positive pulse (128 Tpix_clk wide) or rising edge is active

polv: synchro: active edge of ODDEV/VSYNC selection (when input)

0 = falling edge of ODDEV flags start of field1 (odd field) or VSYNC is active low

(*) 1 = rising edge of ODDEV flags start of field1 (odd field) or VSYNC is active high

freerun:

- (*) 0 = disabled
- 1 = enabled

Note: This bit is taken into account in ODDEV-only or VSYNC-only based slave modes and is irrelevant for other synchronization modes.

REGISTER 1 **configuration1** **Address: 0x0001** **Type: R/W**

content	blkli	flt1	flt0	sync_ok	coki	setup_main		
default	0	1	0	0	0	1	[0]	[0]

blkli: Vertical Blanking Interval selection for active video lines area

(*) 0 = ('partial blanking') Only the following lines inside Vertical Interval are blanked

NTSC-M: lines [1; 9], [263(half); 272] (525-SMPTE)

PAL-M: lines [523; 6], [260(half); 269] (525-CCIR)

Other PAL: lines [623(half); 5], [311; 318] (625-CCIR)

1 = "full blanking" All lines inside VBI are blanked

NTSC-M: lines [1; 19], [263(half); 282] (525-SMPTE)

PAL-M: lines [523; 16], [260(half); 279] (525-CCIR)

Other PAL: lines [623(half); 22], [311; 335] (625-CCIR)

flt[1:0]: U/V Chroma filter bandwidth selection**Table 6. Register 1**

	flt1	flt0	3dB bandwidth	Typical application
	0	0	f-3dB=1.1MHz	low def NTSC filter
	0	1	f-3dB=1.3MHz	low def PAL filter
(*)	1	0	f-3dB=1.6MHz	high def. NTSC filter (ATSC compliant) & PAL M/N (ITU-R 624.4 compliant)
	1	1	f-3dB=1.9MHz	high def. PAL filter: Rec 624 - 4 for PAL BDG/I compliant.

sync_ok: availability of sync signals (analog and digital) in case of input synchronization loss with no free-run active (i.e. freerun=0)

(*) 0 = no synchro output signals

1 = output synchro signals available on YS, CVBS and, when applicable, HSYNC (if output port), ODDEV (if output port): i.e same behavior as free-run except that video outputs are blanked in the active portion of the line.

coki: color killer

(*) 0 = color ON

1 = color suppressed on CVBS output signal (CVBS=YS) but color still present on C output. For color suppression on chroma DAC 'C', see register 5 bit bkdac1.

setup_main: pedestal

0 = Blanking level and black level are identical on all lines.
(e.g.: Argentinian PAL-N, Japan NTSC-M, PAL-BDGHI)

(*) 1 = Black level is 7.5 IRE above blanking level on all lines outside VBI
(e.g. Paraguayan and Uruguayan PAL-N).

In all cases, gain factor is adjusted to obtain the required levels for chrominance.

Note: Depending on the different output configurations chosen by programming bit from *dac12_conf*, pedestal is automatically selected on it.

REGISTER 2 **configuration2** **Address: 0x0002** **Type: R/W**

content	nintrl	enrst	bursten	xxx	selrst	rstosc_buf	valrst1	valrst0
default	0	0	1	0	0	0	0	0

nintrl: non-interlaced mode select

(*) 0 = interlaced mode (625/50 or 525/60 system)

1 = non-interlaced mode(2x312/50 or 2x262/60 system)

enrst: cyclic update of DDFS phase

(*) 0 = no cyclic subcarrier phase reset

1 = cyclic subcarrier phase reset depending of valrst1 and valrst0 (see below)

bursten: chrominance burst control

0 = burst is turned off on CVBS, chrominance output is not affected

(*) 1 = burst is enabled

selrst: selects set of reset values for Direct Digital Frequency Synthesizer accumulator

(*) 0 = hardware reset values for phase of subcarrier oscillator (see description of registers 13 and 14 for values)

1 = loaded reset values selected (see contents of registers 13 and 14)

rstosc_buf: software phase reset of DDFS (Direct Digital Frequency Synthesizer) buffer

(*) 0

1 = when a 0-to-1 transition occurs either the hard-wired default phase value or the value loaded in Reg. 13-14 (according to bit 'selrst') is put to the phase buffer. This value is then loaded into accumulator (phase of sub-carrier) when the bits 'ph_rst_mode' from register 8 are programmed or when standard changes or when a soft reset occur.

Note: Bit 'rstosc_buf' is automatically set back to '0' after the buffer is loaded.

valrst [1:0]

Note: valrst[1:0] is taken into account only if bit 'enrst' is set.

Table 7. valrst1 and valrst0 selection

	valrst1	valrst0	selection
(*)	0	0	Automatic reset of the oscillator every line
	0	1	Automatic reset of the oscillator every 2 nd field
	1	0	Automatic reset of the oscillator every 4 th field
	1	1	Automatic reset of the oscillator every 8 th field

Resetting the oscillator means forcing the value of the phase accumulator to its nominal value to avoid accumulating errors due to the finite number of bits used internally. The value at which the accumulator is reset is either the hard-wired default phase value or the value loaded in Reg. 13-14 (according to bit 'selrst') at which a 0⁰, 90⁰, 180⁰, or 270⁰ correction is applied according to the field and line at which the reset is performed.

REGISTER 3 **configuration3** **Address: 0x0003** **Type: R/W**

content	main_entrapp	trap_4.43			main_del_en	val_422_ck_mux	xxx	
default	0	0	[0]	[0]	0	0	0	[0]

main_entrapp: enable trap filter

(*) 0 = trap filter disabled

1 = trap filter enabled

trap_4.43: trap filter centered frequency value selection

(*) 0 = trap filter centered around 3.58 MHz

1 = trap filter centered around 4.43 MHz

Note: 'trap_4.43' is taken into account only if bit 'main_entrapp' is set.

main_del_en: Enable chroma to luma delay programming on cvbs output:

(*) 0 = disabled (DENC automatically set this delay)

1 = enabled (chroma to luma delay is programmed by del(3:0) bits from register 81.

Note: This delay affects only the cvbs output. The component outputs Y/C remain unaffected. Refer to register 109 to program chroma to luma delay on Y/C output.

val_422_ck_mux: should be programmed to "0" only.

REGISTER 4 **configuration4** **Address: 0x0004** **Type: R/W**

content	syncin_ad1	syncin_ad0	syncout_ad1	syncout_ad0	aline	hue_en	xxx	xxx
default	0	0	0	0	0	0	0	0

syncin_ad[1:0]: Adjustment of incoming sync signals.
Used to insure correct interpretation of incoming video samples as Y, Cr or Cb when the encoder is slaved to incoming sync signals (inc. 'F/H' flags stripped off ITU-R656/D1 data).

Table 8. syncin_ad[1:0]

	syncin_ad1	syncin_ad0	Internal delay undergone by incoming sync
(*)	0	0	nominal*
	0	1	+1 pix_clk
	1	0	+2 pix_clk
	1	1	+3 pix_clk

syncout_ad[1:0]: Adjustment of outgoing sync signals.
Used to ensure correct interpretation of incoming video samples as Y, Cr or Cb when the encoder is master and supplies sync signals.

Table 9. syncout_ad[1:0]

	syncout_ad1	syncout_ad0	Delay added to sync signals before they are output
(*)	0	0	nominal*
	0	1	+1 pix_clk
	1	0	+2 pix_clk
	1	1	+3 pix_clk

aline: video active line duration control

- (*) 0 = Full digital video line encoding (720 pixels - 1440 clock cycles)
- 1 = Active line duration follows ITU-R/SMPTE 'analog' standard requirements

hue_en: Enables variance in phase of the subcarrier, as programmed in register_105, during active video with respect to the phase of the subcarrier during the color burst. Once set, this bit is automatically reset to '0'.

- (*) 0 = Disabled
- 1 = Enabled

REGISTER 5 **configuration5** **Address: 0x0005** **Type: R/W**

content	selrst_inc	bkdac2	bkdac1					dacinv
default	0	0	0	[0]	[0]	[0]	[0]	0

selrst_inc: Choice of Digital Frequency Synthesizer increment after soft reset or when ph_rst_mode = '01' . See Register 8.

- (*) 0 = hard wired value (depending on TV standard)
- 1 = soft (value from registers 10 to 12)

bkdacN: blanking of DACs (N = 1 or 2)

- (*) 0 = DAC N in normal operation
- 1 = DAC N input code forced to black level for C output or blanking level for Y or CVBS output depending of dac12_conf bit of configuration13 register.

dacinv: 'Inverts' DAC codes to compensate for an inverting output stage in the application

- (*) 0 = non inverted DAC inputs (outputs)
- 1 = inverted DAC inputs (outputs)

REGISTER 6 **configuration6** **Address: 0x0006** **Type: R/W**

content	softreset	jump	dec_ninc	free_jump	cfc1	cfc0		maxdyn
default	0	0	0	1	0	0	[0]	0

softreset: software reset

- (*) 0 = no reset
- 1 = software reset

Note: Bit 'softreset' is automatically reset after internal reset generation. Software reset is active during 4 PIX_CLK periods. When softreset is activated, all the device is reset as with hardware reset except for the first nine user registers (registers 0 to 8: configurations). Registers 10 up to 14 (increment and phase of oscillator), 25-30, 31-33 and 39-42 are never reset (hard/soft).

Table 10. jump, dec_ninc, free_jump

	jump	dec_ninc	free_jump	update mode
	0	0	0	Normal mode (no line skip/insert capability) ITU-R (CCIR): 313/312 or 263/262 non-interlaced: 312/312 or 262/262
(*)	0	x	1	Manual mode for line insert ("dec_ninc"=0) or skip ("dec_ninc"=1) capability. Both fields of all the frames following the writing of this value are modified according to "lref" and "ltar" bits of registers 21-22-23 (by default, "lref"=0 and "ltar"=1 which leads to normal mode above).

Table 10. jump, dec_ninc, free_jump

	jump	dec_ninc	free_jump	update mode
	1	0	0	Automatic line insert mode. The 2 nd field of the frame following the writing of this value is increased. Line insertion is done after line 245 in 525/60 and after line 290 in 625/50. "lref" and "ltar" are ignored. ⁽¹⁾
	1	1	0	Automatic line skip mode. The 2 nd field of the frame following the writing of this value is decreased. Line suppression is done after line 245 in 525/60 and after line 290 in 625/50. "lref" and "ltar" are ignored. ⁽¹⁾
	1	x	1	Not to be used.

1. Two lines are skipped (inserted) in 525/60 and four lines in 625/50 standards

Note: bit "jump" is automatically reset after use.

Table 11. cfc[1:0]: color frequency control via CFC line

	cfc1	cfc0	update mode
(*)	0	0	disabled (update is done by loading of registers 10,11 and12)
	0	1	update of increment for DDFS just after serial loading via CFC
	1	0	update of increment for DDFS on next active edge of HSYNC
	1	1	update of increment for DDFS just before next color burst

maxdyn: max dynamic magnitude allowed on YCrCb inputs for encoding.

(*) 0 = 10hex to EBhex for Y, 10hex to F0hex for chrominance (Cr,Cb)

1 = 01hex to FEhex for Y, Cr and Cb

Note: In any case, EAV and SAV words are replaced by blanking values before being fed to the luminance and Chrominance processing.

REGISTER 7 configuration7 Address: 0x0007 Type: R/W

content				xxx		bypass_sync_corr		
default	[0]	[0]	[0]	0	[0]	0	[0]	[0]

bypass_sync_corr: tst_dac bypass mode with sync correction. This is a test mode in which data coming from port tst_dac can be output with or without sync correction and given to the dacs.

(*) 0 = There is no sync correction applicable to the data coming from tst_dac.

1 = Sync correction takes place before setting the dacs provided tst_ana(0) is set to '1'. Please note that in this case only 8 MSBs are used to generate a 10-bit sync corrected output from the filter.

REGISTER 8 configuration8 **Address: 0x0008** **Type: R/W**

content	ph_rst_mode1	ph_rst_mode0	xxx	val_422_mux	blk_all	xxx	xxx	xxx
default	0	0	1	0	0	0	0	0

Table 12. ph_rst_mode[1:0]:sub-carrier phase reset

	ph_rst_mode 1	ph_rst_mode 0	update mode
(*)	0	0	disabled
	0	1	enabled - phase is updated with value from phase buffer register (see Reg2 bit rstosc_buf) at the beginning of the next video line. In the mean time, the increment is updated with hard or soft values depending on selreg_inc value (see Register 5)
	1	0	enabled - phase is updated with values from Registers 10 and 11, based on the next increment update from cfc (depending on cfc loading moment and Register6 cfc(1:0) bits.
	1	1	enabled - phase is reset following the detection of rst bit on cfc line, up to 9 pix_clk after loading of cfc's LSB.

Note: Bits 'ph_rst_mode(1:0)' are automatically set back to '00' following the oscillator reset in modes '01' and '10'.

val_422_mux: should be programmed to "1" only after each reset.

blk_all: blanking of all video lines

(*) 0 = disabled

1 = enabled

(all inputs are ignored - 80hex instead of Cr and Cb and 10hex instead of Y and Y4)

REGISTER 9 **Address: 0x0009** **Type: Read only**

content	hok	atfr			fieldct2	fieldct1	fieldct0	jump
----------------	-----	------	--	--	----------	----------	----------	------

(*) = DEFAULT mode when not_reset pin is active (LOW level)

hok: Hamming decoding of frame sync flag embedded within ITU-R656 / D1 compliant YCrCb streams

0 = Consecutive errors

(*) 1 = A single or no error

Note: Signal quality detector is issued from Hamming decoding of EAV, SAV from YcrCb

atfr: Frame synchronization flag

(*) 0 = encoder not synchronized

1 = in slave mode: encoder synchronized

fieldct[2:0]: Digital field identification number

000 = indicates field 1

...

111 = indicates field 8

fieldct[0] also represents the odd/even information (odd='0', even='1')

jump: indicates whether a frame length modification has been programmed at '1' from programming of bit 'jump' to end of frame(s) concerned.

(*default = 0

Refer to register 6 and registers 21-22-23

REGISTERS 10, 11, 12 Increment_dfs **Address: 0x000A to 0x000C** **Type: R/W**

register_10	d23	d22	d21	d20	d19	d18	d17	d16
register_11	d15	d14	d13	d12	d11	d10	d9	d8
register_12	d7	d6	d5	d4	d3	d2	d1	d0

These registers contain the 24-bit increment used by the DDFS if bit 'selrst_inc' equals '1' to generate the subcarrier phase i.e. the address that is supplied to the sine ROM. It therefore allows to customize the subcarrier synthesized frequency.

1 LSB ~ 1.609325 Hz

The procedure to validate the usage of these registers rather than the hard-wired values is the following:

- Load the registers with the required value
- Set bit 'selrst_inc' to 1 (Reg 5)
- Perform a software reset (Reg 6)

- Note:*
- 1 *The values loaded in Reg10-12 are taken into account after a software reset, and ONLY IF bit 'selrst_inc'='1' (Reg. 5).*
 - 2 *These registers are never reset and must be explicitly written into to contain sensible information.*
 - 3 *On hardware or on software reset with selrst_inc='0', the DDFS is initialized with a hardwired increment, independent of Registers 10-12. These hardwired values being out of any user register cannot be read. These values are:*

Value	Frequency synthesized
d(23:0): 21F07C hexa for NTSC M	f=3.5795452 MHz
d(23:0): 2A098B hexa for PAL B,G,H,I,N	f=4.43361875MHz
d(23:0): 21F694 hexa for PAL N	f=3.5820558 MHz
d(23:0): 21E6F0 hexa for PAL M	f=3.57561149 MHz

REGISTERS 13, 14 Phase_dfs Address: 0x000D to 0x000E Type: R/W

register_13	xxx	xxx	xxx	xxx	xxx	xxx	o23	o22
register_14	o21	o20	o19	o18	o17	o16	o15	o14

Static phase offset for digital frequency synthesizer (10 bits only)

Under certain circumstances (detailed below), these registers contain the 10 MSBs of the value with which the phase accumulator of the DDFS is initialized after a 0-to-1 transition of bit 'rstosc_buf' of Reg 2, or after a standard change, or when cyclic phase readjustment has been programmed (see bits valrst[1:0] of Reg 2). The 14 remaining LSBs loaded into the accumulator in these cases are all '0's (this allows to define the phase reset value with a 0.35° accuracy).

The procedure to validate the usage of these registers rather than the hard-wired values is the following:

- Load the registers with the required value
- Set bit 'selrst' to 1 (Reg 2)
- Perform a software reset or set 'rstosc_buf' to 1 (Reg 2) (to put soft phase value into a tampon register) and ph_rst_mode[1:0]

- Note: 1 Registers 13-14 are never reset and must be explicitly written into to contain sensible information.
- 2 If bit 'selrst'=0 (e.g. after a hardware reset) the phase offset used every time the DDFS is re initialized is a hard-wired value. The hard-wired values being out of any register, they cannot be read out.

Reset values:

D9C000hex for PAL BDGHI, N, M,
 1FC000hex for NTSC-M,
 000000hex (blue lines)

REGISTER 17 **dac2 multiplying factors** **Address: 0x0011** **Type: R/W**

content	dac2_mult5	dac2_mult4	dac2_mult3	dac2_mult2	dac2_mult1	dac2_mult0		
default	1	0	0	0	0	0	[1]	[0]

dac2_mult[5:0]: multiplying factor on dac2_c digital signal before the D/A converters with 0.78% step.

Table 13. dac2_mult[5:0]: multiplying factor on dac2_c digital signal

	dac2_mult[5:0]						
	0	0	0	0	0	0	75.00%
	0	0	0	0	0	1	75.78%
	0	0	0	0	1	0	76.56%
	0	0	0	0	1	1	77.34%

(*)	1	0	0	0	0	0	100%

	1	1	1	1	1	1	124.22%

REGISTERS 21, 22, 23 **Address: 0x0015 to 0x0017** **Type: R/W**
clig_i_reg = ltarg[8:0] and lref[8:0]

register 21	ltarg8	ltarg7	ltarg6	ltarg5	ltarg4	ltarg3	ltarg2	ltarg1
register 22	ltarg0	lref8	lref7	lref6	lref5	lref4	lref3	lref2
register 23	lref1	lref0	-	-	-	-	-	-

These registers may be used to jump from a reference line (end of that line) to a target line of the SAME FIELD. However, not all lines can be skipped or repeated with no problems and, if needed, this functionality should BE USED WITH CAUTION.

lref[8:0] contains, in binary format, the reference line from which a jump is required. ltarg[8:0] contains the target line as a binary number.

Default values: lref[8:0]:= 00000000 and ltarg[8:0]:= 00000001.

REGISTER 65 **C_mult&txs** **Address: 0x0041** **Type: R/W**

content	c_mult3	c_mult2	c_mult1	c_mult0		xxx		bcs_en_main
default	0	0	0	0	[0]	0	[0]	1

c_mult[3:0]: multiplying factor of C digital output (before D/A convertors) and of color part of CVBS signal.

Table 14. c_mult[3:0]: multiplying factor of C digital output

	c_mult3	c_mult2	c_mult1	c_mult0	factor value (c_mult)
(*)	0	0	0	0	1.000000 (1.000000 Dec.)
	0	0	0	1	1.000001 (1.015625 Dec.)
	0	0	1	0	1.000010 (1.031250 Dec.)
	0	0	1	1	1.000011 (1.046875 Dec.)

	1	1	1	1	1.001111 (1.234375 Dec.)

bcs_en_main: Brightness, Contrast and Saturation control by Registers 69 to 71 on 4:4:4 video input

0 = disable

(*) 1 = enable

REGISTER 69 **Brightness** **Address: 0x0045** **Type: R/W**

content	b7	b6	b5	b4	b3	b2	b1	b0
default	1	0	0	0	0	0	0	0

To adjust the luminance intensity of the display video image, the following formula is used:

$$Y_{out} = Y_{in} + b - 128$$

Y_{in} is the 8-bit input luminance

Y_{out} is the result of 'Brightness' operation (still on 8 bits)

This value is saturated at 235 (16) or 254 (1) according to register6 bit 'maxdyn',

b: brightness (unsigned value with center at 128, default 128)

REGISTER 70 Contrast Address: 0x0046 Type: R/W

content	c7	c6	c5	c4	c3	c2	c1	c0
default	0	0	0	0	0	0	0	0

Adjustment of the relative difference between high and low intensity luminance values of the displayed image is made according to the following formula:

$$Y_{out} = \frac{(Y_{in}-128)(c + 128)}{128} + 128$$

Yin is the 8-bit input luminance,

Yout is the result of 'Contrast' operation (still on 8 bits)

This value is saturated at 235 (16) or 254 (1) according to register6 bit 'maxdyn',

c: contrast (2's complement value from -128 to 127, default 0)

REGISTER 71 Saturation Address: 0x0047 Type: R/W

content	s7	s6	s5	s4	s3	s2	s1	s0
default	1	0	0	0	0	0	0	0

To adjust the color intensity of the displayed video image, the following formula is used:

$$C_{bout} = \frac{s(C_{bin} - 128)}{128} + 128$$

$$C_{rout} = \frac{s(C_{rin} - 128)}{128} + 128$$

Crin, Cbin 8-bit input chroma,

Crout, Cbout the result of 'Saturation' operation (still on 8 bits)

This value is saturated at 240 (16) or 254 (1) according to bit 'maxdyn' (Reg 6),

s: saturation value (unsigned value with centre at 128, default 128)

REGISTERS 72 to 80
Chroma filter coefficients
Address:
0x0048 to 0x0050 **Type: R/W**
Table 15. Chroma main_coef [8:0]

chroma_main_coef_0	reg_72	main_ft_s	main_plg_div1	main_plg_div0	coef0(4)	coef0(3)	coef0(2)	coef0(1)	coef0(0)
chroma_main_coef_1	reg_73	xxx	coef8(8)	coef1(5)	coef1(4)	coef1(3)	coef1(2)	coef1(1)	coef1(0)
chroma_main_coef_2	reg_74	xxx	coef2(6)	coef2(5)	coef2(4)	coef2(3)	coef2(2)	coef2(1)	coef2(0)
chroma_main_coef_3	reg_75	xxx	coef3(6)	coef3(5)	coef3(4)	coef3(3)	coef3(2)	coef3(1)	coef3(0)
chroma_main_coef_4	reg_76	coef4(7)	coef4(6)	coef4(5)	coef4(4)	coef4(3)	coef4(2)	coef4(1)	coef4(0)
chroma_main_coef_5	reg_77	coef5(7)	coef5(6)	coef5(5)	coef5(4)	coef5(3)	coef5(2)	coef5(1)	coef5(0)
chroma_main_coef_6	reg_78	coef6(7)	coef6(6)	coef6(5)	coef6(4)	coef6(3)	coef6(2)	coef6(1)	coef6(0)
chroma_main_coef_7	reg_79	coef7(7)	coef7(6)	coef7(5)	coef7(4)	coef7(3)	coef7(2)	coef7(1)	coef7(0)
chroma_main_coef_8	reg_80	coef8(7)	coef8(6)	coef8(5)	coef8(4)	coef8(3)	coef8(2)	coef8(1)	coef8(0)

Values from these registers are used only when bit `main_ft_s` (Reg 72) is set to 1. Bit `main_ft_s` has the highest priority over the rest. With `main_ft_s` bit set to 1, all bits from `main_plg_div[1:0]` need to be programmed to the chroma coefficients. Alternatively, the coefficients default values are loaded depending on the selected mode or the selected filter type in a particular mode with `flt(1:0)` bits from register 1.

The values are soft loaded when `main_ft_s = 1`. The value to be loaded in the register should be the actual coefficient value + an offset. The hardware will internally subtract this offset to get the actual coefficient value.

main_ft-s default value: 0

The `main_plg_div` value is chosen according to the sum of all the coefficients.

main_plg_div = 11 when sum of coeffs = 4096

main_plg_div = 10 when sum of coeffs = 2048

main_plg_div = 01 when sum of coeffs = 1024, (default)

main_plg_div = 00 when sum of coeffs = 512

Offset change before loading to user register:

chroma_main_coef0 = Actual value + 16;

chroma_main_coef1 = Actual value + 32;

chroma_main_coef2 = Actual value + 64;

chroma_main_coef3 = Actual value + 32;

chroma_main_coef4 = Actual value + 32;

chroma_main_coef5 = Actual value + 32;

chroma_main_coef6 = Actual value

chroma_main_coef7 = Actual value

chroma_main_coef8 = Actual value

Default values:

chroma_main_coef0[4:0] = 10001 means $c_0 = 1$.

chroma_main_coef1[5:0] = 100111 means $c_1 = 7$;

chroma_main_coef2[6:0] = 1010100 means $c_2 = 20$;

chroma_main_coef3[6:0] = 1000111 means $c_3 = 39$;

chroma_main_coef4[7:0] = 01011111 means $c_4 = 63$;

chroma_main_coef5[7:0] = 01110111 means $c_5 = 87$;

chroma_main_coef6[7:0] = 01101100 means $c_6 = 108$;

chroma_main_coef7[7:0] = 01111011 means $c_7 = 123$;

chroma_main_coef8[8:0] = 010000000 means $c_8 = 128$.

The FIR symmetrical filter has the following response:

$$H(z) = c_0 + c_1 z^{-1} + c_2 z^{-2} + \dots + c_7 z^{-7} + c_8 z^{-8} + c_7 z^{-9} + \dots + c_2 z^{-14} + c_1 z^{-15} + c_0 z^{-16}$$

The filter working frequency is comprised in the range [pix_clk, 27 MHz] and the filtering is done on upsampled signal (half pix_clk to pix_clk frequency by padding by zeros).

REGISTER 81 Configuration 9 Address: 0x0051 Type: R/W

content	main_de l3	main_de l2	main_de l1	main_de l0	xxx	plg_div_ y1	plg_div_ y0	flt_ys
default	0	0	1	0	0	0	1	0

main_del[3:0]: delay on chroma path with reference to luma path, on the encoded signal coming from the main outputs. The delay value varies with modes, delays are hardwired to have different delays in different modes. If the delays are to be made programmable, set bit main_del_en to 1 (Reg 03) to enable soft delay from main_del[3:0].

Table 16. main_del[3:0]

	main_ del3	main_ del2	main_ del1	main_ del0	Delay on chroma path with reference to luma path encoding [One pixel corresponds to $2/f_{pix_clk}$]
(*)	0	0	1	0	- 0.5 pixel delay on chroma
	0	0	1	1	- 1 pixel delay on chroma
	0	1	0	0	- 1.5 pixel delay on chroma
	0	1	0	1	- 2 pixel delay on chroma
	1	1	0	0	+ 2.5 pixel delay on chroma
	1	1	0	1	+ 2 pixel delay on chroma
	1	1	1	0	+ 1.5 pixel delay on chroma
	1	1	1	1	+ 1 pixel delay on chroma
	Others			1	0 pixel delay on chroma (reference delay)
	Others			0	+ 0.5 pixel delay on chroma

If main_del_en = 0 then the delays used are:

main_del[3:0] = 0010 when mode = PAL/NTSC in 4:2:2 format on CVBS

main_del[3:0] = 0001 when mode = PAL/NTSC in 4:4:4.

plg_div_y = 00 when sum of coefficients = 256

plg_div_y = 01 when sum of coefficients = 512 (default)

plg_div_y = 10 when sum of coefficients = 1024

plg_div_y = 11 when sum of coefficients = 2048

Bit flt_ys enables the software loading capability of luma coefficients. Values from registers 82 to 91 are used only when bit "flt_ys" of this register is set to 1. Bit "flt_ys" has the highest priority. With this bit set to 1, all bits from plg_div_y[1:0] must be programmed as luma coefficients. Alternatively, the default values of the coefficients are loaded. The luma coefficients are mode and standard independent.

flt_ys default value is "0".

REGISTERS 82 to 91: **luma filter coefficients** Address: **0x0052 to 0x005B** Type: R/W

Table 17. Luma_coef_[0:9]

luma_coef_0	reg_82	xxx	xxx	l8(8)	l0(4)	l0(3)	l0(2)	l0(1)	l0(0)
luma_coef_1	reg_83	l9(9)	l9(8)	l1(5)	l1(4)	l1(3)	l1(2)	l1(1)	l1(0)
luma_coef_2	reg_84	l6(8)	l2(6)	l2(5)	l2(4)	l2(3)	l2(2)	l2(1)	l2(0)
luma_coef_3	reg_85	l7(8)	l3(6)	l3(5)	l3(4)	l3(3)	l3(2)	l3(1)	l3(0)
luma_coef_4	reg_86	l4(7)	l4(6)	l4(5)	l4(4)	l4(3)	l4(2)	l4(1)	l4(0)
luma_coef_5	reg_87	l5(7)	l5(6)	l5(5)	l5(4)	l5(3)	l5(2)	l5(1)	l5(0)
luma_coef_6	reg_88	l6(7)	l6(6)	l6(5)	l6(4)	l6(3)	l6(2)	l6(1)	l6(0)
luma_coef_7	reg_89	l7(7)	l7(6)	l7(5)	l7(4)	l7(3)	l7(2)	l7(1)	l7(0)
luma_coef_8	reg_90	l8(7)	l8(6)	l8(5)	l8(4)	l8(3)	l8(2)	l8(1)	l8(0)
luma_coef_9	reg_91	l9(7)	l9(6)	l9(5)	l9(4)	l9(3)	l9(2)	l9(1)	l9(0)

Values from these registers are used only when bit *flt_ys* of register 81 is set to 1.

The coefficient values of *luma_coef_0* to *luma_coef_7* should be entered as 2's complement, and the rest as normal positive values. The hardware will internally generate normal positive values. Default values:

- a0 = luma_coef_0[4:0] = 00001** means +1;
- a1 = luma_coef_1[5:0] = 111111** means -1;
- a2 = luma_coef_2[6:0] = 1110111** means -9;
- a3 = luma_coef_3[6:0] = 0000011** means +3;
- a4 = luma_coef_4[7:0] = 00011111** means +31;
- a5 = luma_coef_5[7:0] = 11111011** means -5;
- a6 = luma_coef_6[8:0] = 110101100** means -84;
- a7 = luma_coef_7[8:0] = 000000111** means +7;
- a8 = luma_coef_8[8:0] = 100111101** means +317;
- a9 = luma_coef_9[9:0] = 0111111000** means +504;

The FIR filter is symmetrical with the following response:

$$H(z) = a_0 + a_1z^{-1} + a_2z^{-2} + \dots + a_8z^{-8} + a_9z^{-9} + a_8z^{-10} + \dots + a_2z^{-16} + a_1z^{-17} + a_0$$

Working frequency of this filter is the one of *pix_clk* (27, 24.545454 or 29.5 MHz), and the filtering is done on upsampled signal (half *pix_clk* to *pix_clk* frequency by padding by zeros).

REGISTER 93 Configuration 11 Address: 0x005D Type: R/W

content					xxx	main_if_ del	xxx	xxx
default	[0]	[0]	[1]	[0]	1	0	0	0

main_if_del: The delay on the luma comparing to chroma in CVBS and S-VHS outputs. This delay is 5 clock cycles (27 MHz clock).

- (*) 0 = enabled
- 1 = disabled

REGISTER 94 Configuration 12 Address: 0x005E Type: R/W

content		xxx	xxx	xxx		ennotch		xxx
default	[0]	0	0	0	[0]	0	[0]	0

ennotch: Notch filtering on the cvbs output

- (*) 0 = disabled
- 1 = enabled

REGISTER 95 Configuration 13 Address: 0x005F Type: R/W

content			dac12_ conf					
default	[0]	[0]	0	[0]	[0]	[0]	[0]	[1]

dac12_conf: Please refer to the table below for all combinations to be observed at DACs.

Table 18. dac12_conf

dac12_conf	dac1	dac2
(*)0	Y	C
1		CVBS

REGISTER 105 Hue control Address: 0x0069 Type: R/W

content	hue_ cont (7)	hue_ cont (6)	hue_ con t (5)	hue_ cont (4)	hue_ cont (3)	hue_ cont (2)	hue_ cont (1)	hue_ cont (0)
default	0	0	0	0	0	0	0	0

Defines the phase shift in the subcarrier during active video with respect to the subcarrier phase during the color burst. Once enabled by Register_4(2) "hue_en", phase variation would be in a range of +/- 22.324 degrees with increments of 0.17578127.

Note: Pulse the Register_4(2) "hue_en" to make sure that a value programmed in this register is effective immediately after programming Hue_control. Once enabled, to disable any phase shift in active subcarrier wrt burst, write the default value into the Hue_control register followed by a pulse on Register_4(2) "hue_en".

hue_control [6:0]: absolute value of phase adjustment, range 1 to 127.
 LSB (0x01) implies 0.17578127 degrees, 0x7F imply 22.324 degrees

hue_control [7]: Sign of phase

1 = +ve; (*) 0 = -ve

(*)

- “00000000” : No phase shift
- “10000000” : No phase shift
- “11111111” : +22.324 degrees phase
- “01111111” : -22.324 degrees phase

REGISTER 106 **dac1 multiplying factor** **Address: 0x006A** **Type: R/W**

content	xxx	xxx	dac1_ mult5	dac1_ mult4	dac1_ mult3	dac1_ mult2	dac1_ mult1	dac1_ mult0
default	0	0	1	0	0	0	0	0

dac1_mult(5:0): multiplying factor on dac1_y digital signal before the D/A converters with 0.78% step.

Table 19. dac1_multi[5:0]

dac1_mult[5:0]							
	0	0	0	0	0	0	75.00%
	0	0	0	0	0	1	75.78%
	0	0	0	0	1	0	76.56%
	0	0	0	0	1	1	77.34%

(*)	1	0	0	0	0	0	100%

	1	1	1	1	1	1	124.22%

REGISTER 108 **Chroma Delay** **Address: 0x006C** **Type: R/W**

content					main_chr_ del3	main_chr_ del2	main_chr_ del1	main_chr_ del0
default	[0]	[0]	[0]	[0]	0	0	1	0

main_chr_del[3:0]: delay on chroma path with reference to luma path on encoded component outputs. The delay value varies with modes and the delays are hardwired to have different delays in different modes. If the delays are to be made programmable make bitmain_chr_del_en = 1 (Reg 109). That way, soft delay from main_chr_del[3:0] is enabled.

Table 20. main_chr_del[3:0]

	main_chr_del3	main_chr_del2	main_chr_del1	main_chr_del0	Delay on chroma path with reference to luma path encoding [One pixel corresponds to /fpix_clk]
(*)	0	0	1	0	- 0.5 pixel delay on chroma
	0	0	1	1	- 1 pixel delay on chroma
	0	1	0	0	- 1.5 pixel delay on chroma
	0	1	0	1	- 2 pixel delay on chroma
	1	1	0	0	+ 2.5 pixel delay on chroma
	1	1	0	1	+ 2 pixel delay on chroma
	1	1	1	0	+ 1.5 pixel delay on chroma
	1	1	1	1	+ 1 pixel delay on chroma
	Others			1	0 pixel delay on chroma (reference delay)
	Others			0	+ 0.5 pixel delay on chroma

If main_chr_del_en = 0 then the delays used are:

main_chr_del[3:0] = 0010 when mode = PAL/NTSC in 4:2:2 format on CVBS.

main_chr_del[3:0] = 0001 when mode = PAL/NTSC in 4:4:4

REGISTER 109 **Chroma Delay Enable** **Address: 0x006D** **Type: R/W**

content								main_chr_del_en
default	-	-	-	-	-	[0]	[0]	0

main_chr_del_en: Enable of luma to chroma delay on the 4:4:4 component outputs.

(*) 0 = disabled (DENC automatically sets this delay)

1 = enabled (chroma to luma delay is programmed by main_chr_del[3:0] bits (Reg 108).

Note: This delay affects only the component Y/C. The cvbs output remains unaffected. Refer to register 3 to program chroma to luma delay on cvbs output signal.

5.2.2 Control & power management unit registers

Control and power management unit

REGISTER 128 Configuration0 Address: 0x0080 Type: R/W

content								standby
default	0	0	0	0	0	0	0	0

standby: In this mode the analog subsystem is supplied by the 1.2V/1.4V and the 2.8V/3.3V, but the DACs are set in power down mode, via poff[1:2] bits (Reg 130 & 131). Digital to analog data conversion is disabled.

- (*) 0 = disabled (active mode)
- 1 = standby

Control and power management unit reset

REGISTER 129 Configuration 1 Address: 0x0081 Type: R/W

content								cpmuswrst
default	0	0	0	0	0	0	0	0

cpmuswrst: Control and power management unit reset

- (*) 0 = disabled
- 1 = control and power management unit software reset

Note: Bit cpmuswrst is automatically reset to its default value after internal reset generation and the I2C data transfer is stopped. This reset is kept available for a CLK cycle.

REGISTER 130 DAC1 control Address: 0x0082 Type: R/W

content						poff1	notzerod1	pedestal Ond1
default	0	0	0	0	0	1	1	0

poff1: DAC2 power off, then turn off DAC2 is in a low power consumption mode

- 0 = disabled (DAC2 active)
- (*) 1 = turned off

Note: As Default value is "1", Digital processor must write "0" when going from sleep or standby to active mode.

notzerod1 : null digital data inputed on DAC2

- 0 = independently of what is coming from the digital part, "0000000000" is forced on DAC2 input.
- (*) 1 = disabled, values issued from DENC are transmitted to DAC2.

pedestalOnd1 : Black level video pedestal active on DAC2

- (*) 0 = disabled
- 1 = video pedestal active

REGISTER 131 DAC2 control Address: 0x0083 Type: R/W

content						poff2	notzerod2	pedestal Ond2
default	0	0	0	0	0	1	1	0

poff2: DAC1 power off, then turn off DAC1 is in a low power consumption mode.
 0 = disabled (DAC1 active)
 (*)1 = turned off

Note: As Default value is "1", Digital processor must write "0" when going from sleep or standby to active mode.

notzerod2 : null digital data input on DAC1
 0 = independently of that is coming from the digital part, "0000000000" is forced on DAC1 input.
 (*)1 = disabled, values issued from DENC are transmitted to DAC1.

pedestalOnd2: Black level video pedestal active on DAC1
 (*) 0 = disabled
 1 = video pedestal active

REGISTER 132 Plugdet Address: 0x0084 Type: R

content								LoadD
default	-	-	-	-	-	-	-	-

LoadD: Reports Plugdet Ball status. Unless otherwise specified all voltages are referenced to GND.
 0 = Plugdet ball voltage less than VIL
 1 = Plugdet ball voltage higher than VIH

6 Bus interface

6.1 2 wire serial MPU control interface (I2C compatible)

STw80x9 serial MPU control interface is compliant with I2C standard and acts only as a slave device. It supports 100 kHz and 400 kHz speeds. In addition to the basic definition of the I2C standard (SDA & SCL signals), STw80x9 serial MPU interface has an additional “Add” input used to select one out of two slave addresses.

The device supports 7-bit and 10-bit addresses.

Table 21. STw80x9 addresses

	7-bit addresses		10-bit addresses	
	Read	Write	Read	Write
Add pin = 0	01000001	01000000	00001000001	00001000000
Add pin = 1	01000011	01000010	00001000011	00001000010

7-bit address mode

In Write mode, several data can be sent without re-initializing a transfer and data is written in successive registers. ([Figure 18: 2-wire serial MPU control interface format \(I2C compatible\) / 7-bit addresses](#)).

In Read mode: ([Figure 18](#)).

- Double transaction read: The operation is split into two transactions:
The first one is a write that transmits the desired address. The I2C interface memorizes the address of the register.
The second transfer is a read that can be repeated to read successive registers. After each read byte and except for the last one, the master issues an “acknowledge”. The master indicates that it is reading the last byte by issuing a “no acknowledge” instead of an “acknowledge”.
- Single transaction read:
As opposed to the double transaction, instead of stopping the first transaction and starting the second one, the transactions are combined with a repeated start condition.

Figure 18. 2-wire serial MPU control interface format (I2C compatible) / 7-bit addresses

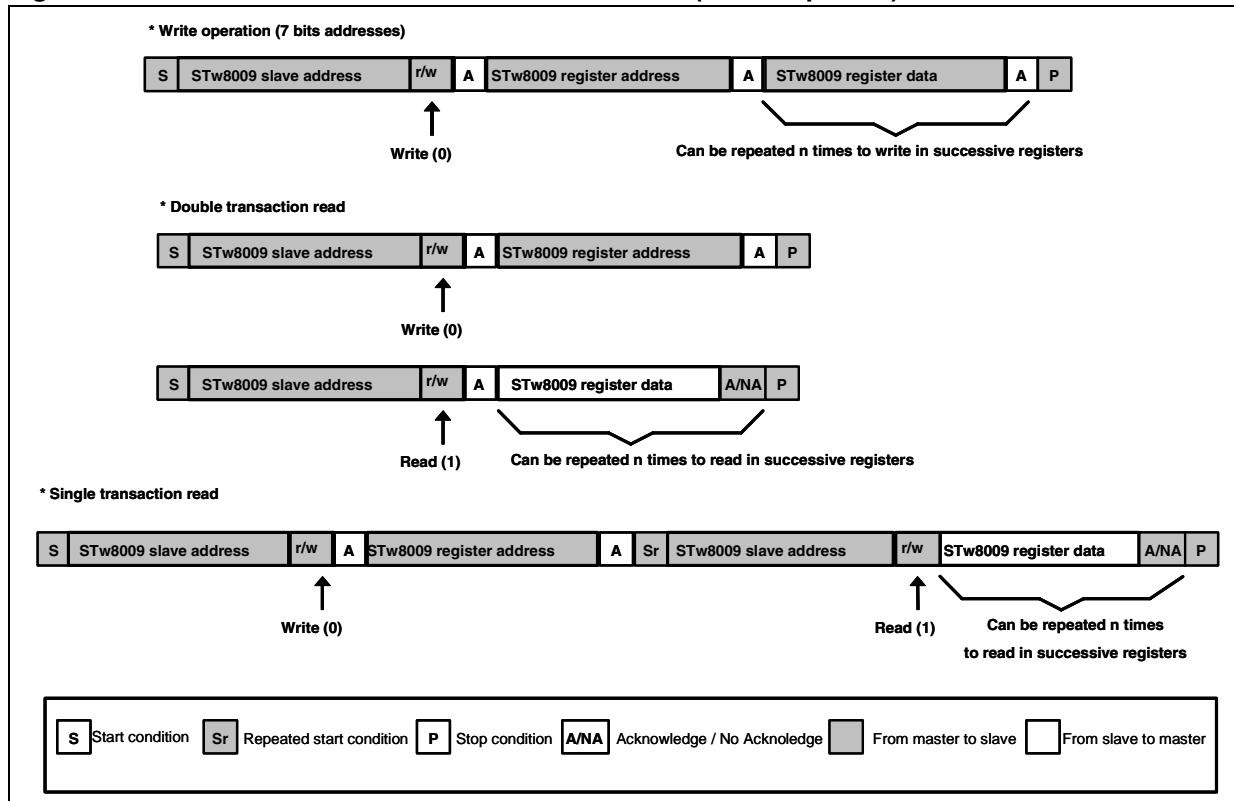

10 bits address mode

In Write mode, several data can be sent without re-initializing a transfer, in this case, data is written in successive registers. (Figure 19: 2-wire serial MPU control interface format (I2C compatible) / 10-bit addresses)

In Read mode: (Figure 19)

- Double transaction read:
The operation is split into two transactions:
The first one is a write that transmits the desired address. The I2C interface memorizes the address of the register.
The second transfer is a read that can be repeated to read successive registers. After each read byte and except for the last one, the master issues an “acknowledge”. The master indicates that it is reading the last byte by issuing a “no acknowledge” instead of an “acknowledge”.

Note: Only the higher part of the address is sent again before sending the read indication.

- Single transaction read:
As opposed to the double transaction, instead of stopping the first transaction and starting the second one, the transactions are combined with a repeated start condition.

Figure 19. 2-wire serial MPU control interface format (I2C compatible) / 10-bit addresses

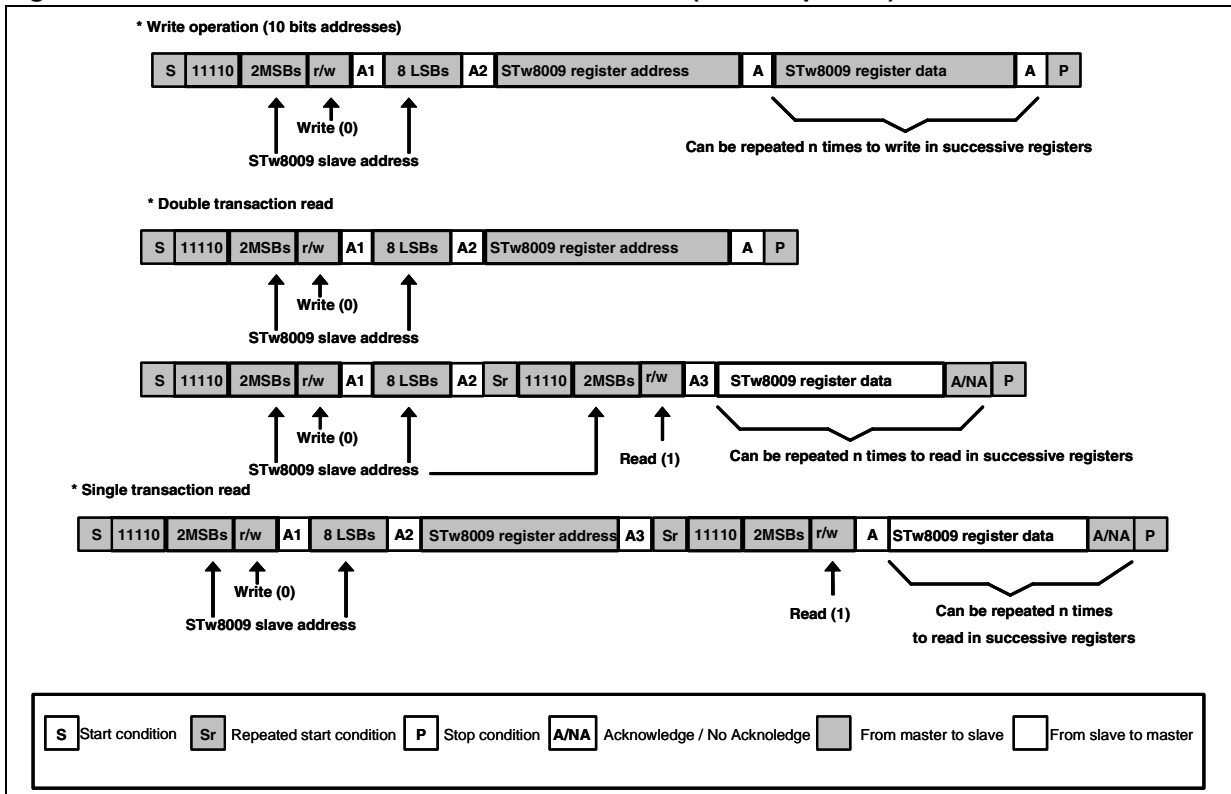
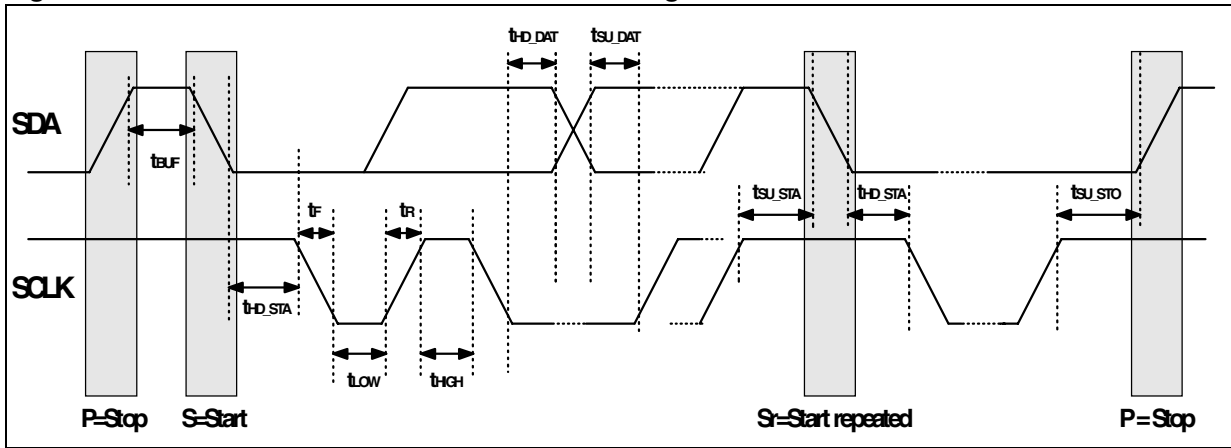

Figure 20. 2-wire serial MPU control interface timing



6.2 YcbCr bus

Figure 21. YcbCr bus format

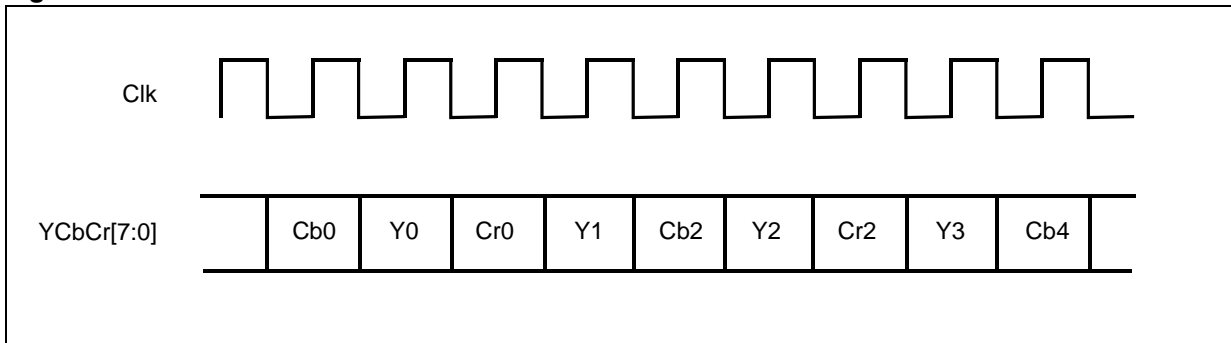
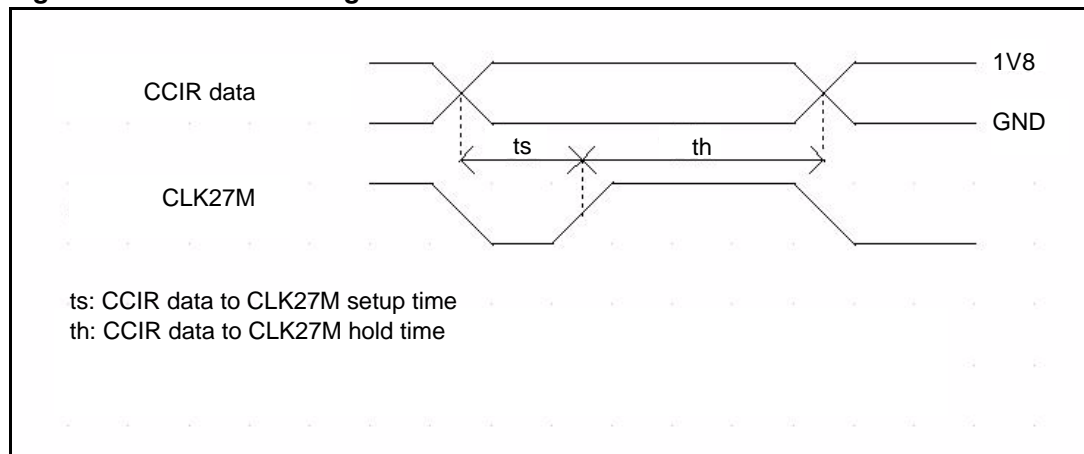

Table 22. YcBCr data bus timing (Figure 22)

Symbol	Parameter	Test conditions	Min.	Typ.	Max.	Unit
CLK27M	Clock frequency			27		MHz
CLKdc	Clock duty cycle		45		55	%
th	Data input hold time		3			ns
ts	Data input setup time		1.5			ns

Figure 22. Data bus timing



7 Electrical characteristics

7.1 Absolute maximum rating

Unless otherwise specified: $T_A=+25^{\circ}\text{C}$, all voltages are referenced to GND.

Table 23. Absolute maximum ratings

Symbol	Parameter		Value	Unit
Vdd	Digital core supply voltage		-0.3 to +1.65	V
VddIO	I/O digital supply voltage		-0.3 to +3.6	V
VccA	Analog supply voltage		-0.3 to +3.8	V
VDCdig	DC input voltage on any digital pin		-0.3 to +2.0	V
VDCana	DC input voltage on any analog pin		-0.3 to +3.8	V
Pmax	Maximum power dissipation		700	mW
T _{stg}	Storage temperature range		-40 to 125	°C
Vesd	Electrostatic discharge voltage	Human body model ⁽¹⁾	-2 to +2	KV
		Charge device model ⁽²⁾	-500 to +500	V

1. HBM tests have been performed in compliance with JESD22-A114-B and ESD STM 5.1-2001.HBM

2. CDM tests have been performed in compliance with CDM ANSI-ESDSTM5.3.1-1999

7.2 Operating conditions

Unless otherwise specified: $T_A=+25^{\circ}\text{C}$, all voltages are referenced to GND.

Table 24. Operating conditions

Symbol	Parameter	Min.	Typ.	Max.	Unit
Vdd	Digital core supply voltage	1.08	1.2	1.47	V
VddIO	I/O digital supply voltage	1.65	1.8	3.0	V
VccA	Analog supply voltage	2.7		3.6	V
T _A	Operating temperature	-30		+85	°C

7.3 Electrical and timing characteristics

Unless otherwise specified: $T_A=+25^{\circ}\text{C}$, all voltages are referenced to GND.

Table 25. 2 wire serial MPU control interface timing (Figure 20)

Symbol	Parameter	Test conditions	Min.	Typ.	Max.	Unit
f_{SCL}	Clock Frequency				400	kHz
t_{BUF}	Bus free time		1300			ns
$t_{\text{HD_STA}}$	Start condition hold time		600			ns
t_f	SDA & SCLK fall time				300	ns
t_{LOW}	SCLK pulse width low		1300			ns
t_r	SDA & SCLK rise time				300	ns
t_{HIGH}	SCLK pulse width high		600			ns
$t_{\text{HD_DAT}}$	Data input hold time		0			ns
$t_{\text{SU_DAT}}$	Data input set up time		100			ns
$t_{\text{SU_STA}}$	Start condition set up time		600			ns
$t_{\text{SU_STO}}$	Stop condition set up time		600			ns

Table 26. Digital I/O interface

Symbol	Parameter	Test conditions	Min.	Typ.	Max.	Unit
V_{IL}	Input Low voltage	All digital inputs			$0.2 \cdot V_{\text{ddIO}}$	V
V_{IH}	Input High voltage	All digital inputs	$0.7 \cdot V_{\text{ddIO}}$			V
V_{OL}	Output Low level	All digital outputs			$0.1 \cdot V_{\text{ddIO}}$	V
V_{OH}	Output High level	All digital outputs	$0.8 \cdot V_{\text{ddIO}}$			V
I_{IL}	Input Low current	All digital inputs / $0\text{V} < V_{\text{in}} < V_{\text{IL}}$	-10		10	μA
I_{IH}	Input High current	All digital inputs / $V_{\text{CCIO}} < V_{\text{in}} < V_{\text{IH}}$	-10		10	μA

Table 27. Power consumption/R load = 37.5 ohm

Symbol	Parameter	Test conditions	Min.	Typ.	Max.	Unit
PSL _{Vdd}	Sleep mode on Vdd	Vdd = 1.2V no 27 MHz clock		3		μW
PST _{Vdd}	Stand by mode on Vdd	Vdd = 1.2V		150		μW
PST _{Vcca}	Stand by mode on Vcca	Vcca = 2.8V		1		μW
PAC _{Vdd}	Active mode on Vdd	Vdd = 1.2 V 0, 1 or 2 DAC enabled		5		mW
PAC _{VddIO}	Active mode on VddIO	VddIO = 1.8V		180		μW
PAC0 _{Vcca}	Active mode on Vcca	Vcca = 2.8V no DAC enabled		2		μW
PAC1 _{Vcca}	Active mode on Vcca	Vcca = 2.8V 1 DAC enabled		120		mW
PAC2 _{Vcca}	Active mode on Vcca	Vcca = 2.8V 2 DAC enabled		240		mW

Table 28. DAC & Video output characteristics / Rload = 37.5 ohm – F = 27 MHz – Rext = 2.4 kohm

Symbol	Parameter	Test conditions	Min.	Typ.	Max.	Unit
R _{DAC}	Resolution			10		Bits
INL _{DAC}	Integral non linearity		-1.5		+1.5	LSB
DNL _{DAC}	Differential non linearity		-0.8		+0.8	LSB
VFR1	Full range output voltage	Pedestal on low	1.14	1.21	1.27	V
VFR2	Full range output voltage	Pedestal on high	1.24	1.31	1.38	V
SFDR	Spurious free dynamic range	F = 1 MHz / 1 Vpp	TBD	49		dB
SNR	Signal to noise ratio	With white level	55	62		dB
PSRR	Power supply rejection ratio	2.8 V supply / F = 200 Hz		65		dB
DiffG	Differential gain	Average measurements on VSA R&S on NTC7comp and CCIR17 line test patterns		1		%
DiffPh	Differential phase	Average measurements on VSA R&S on NTC7comp and CCIR17 line test patterns		1		deg

8 Application information

Figure 23. Typical application schematic

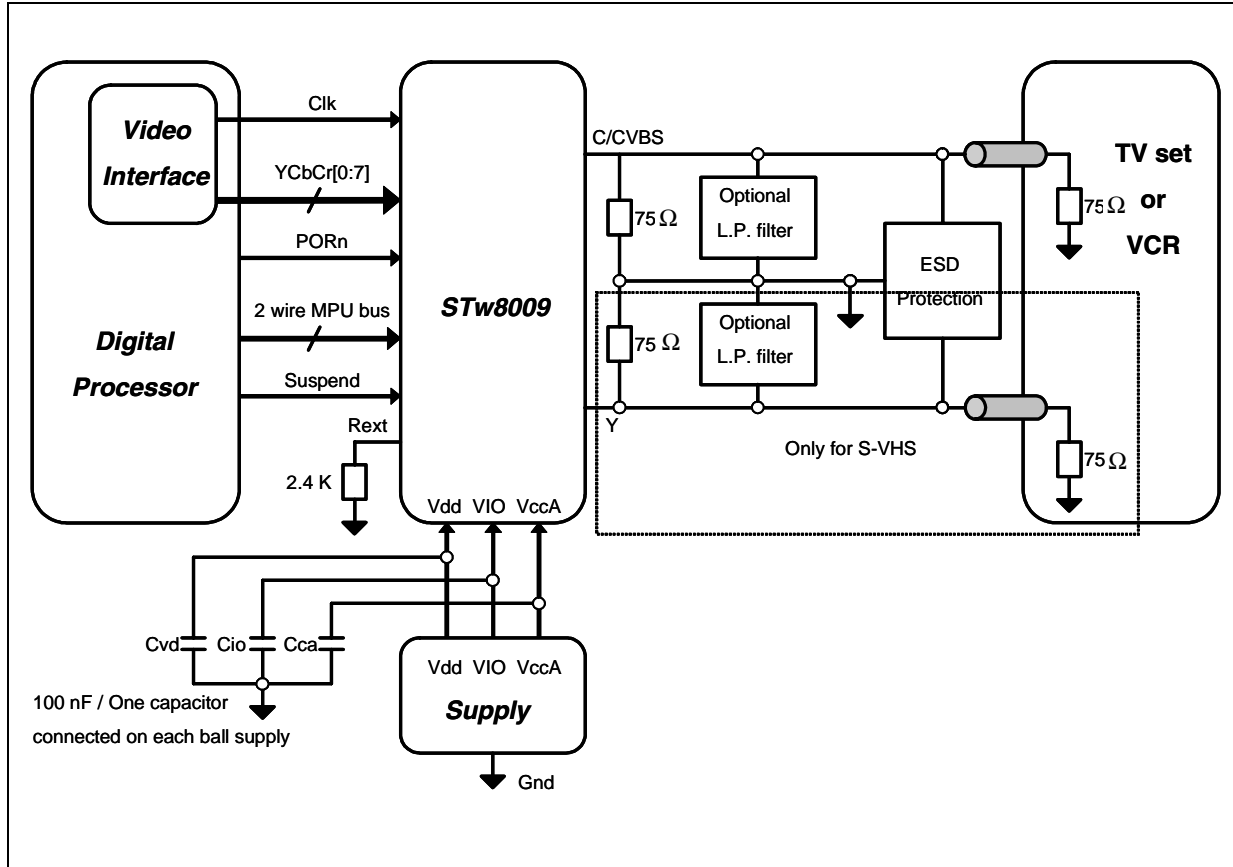

9 Color test pattern waveforms

Figure 24. NTSC composite

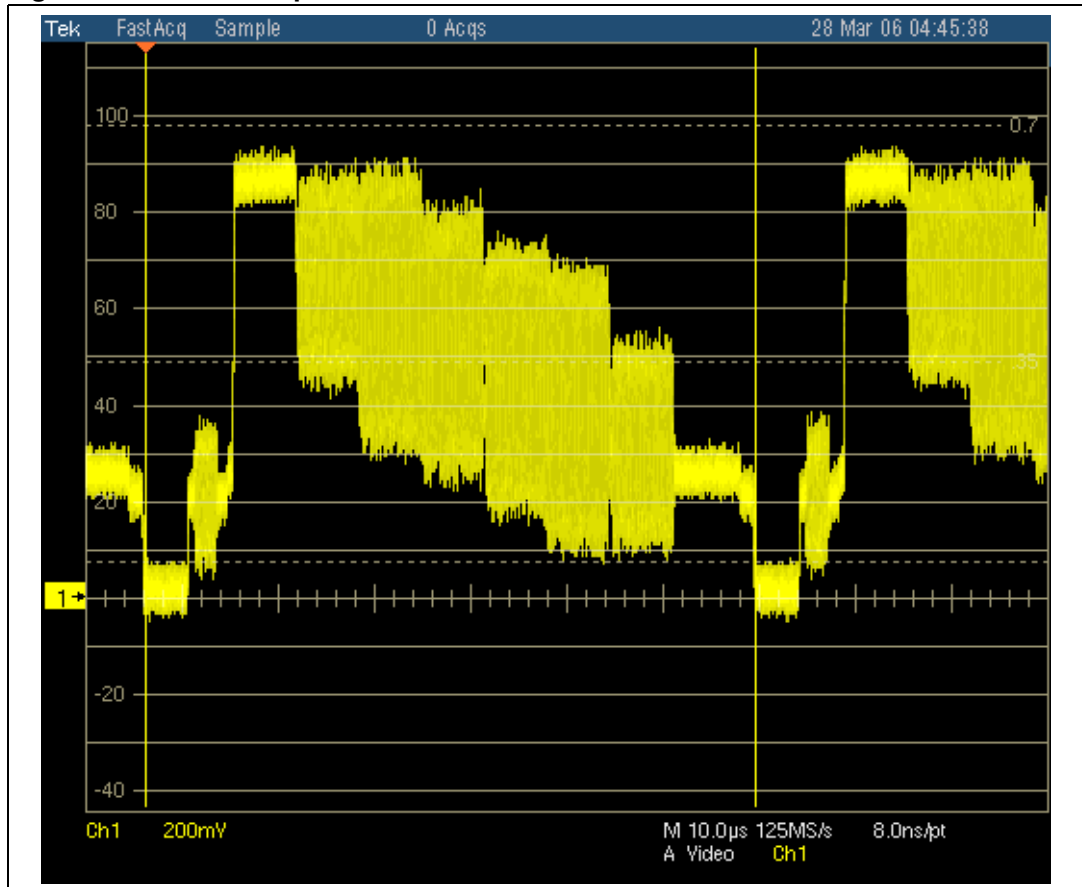

Figure 25. NTSC S-video

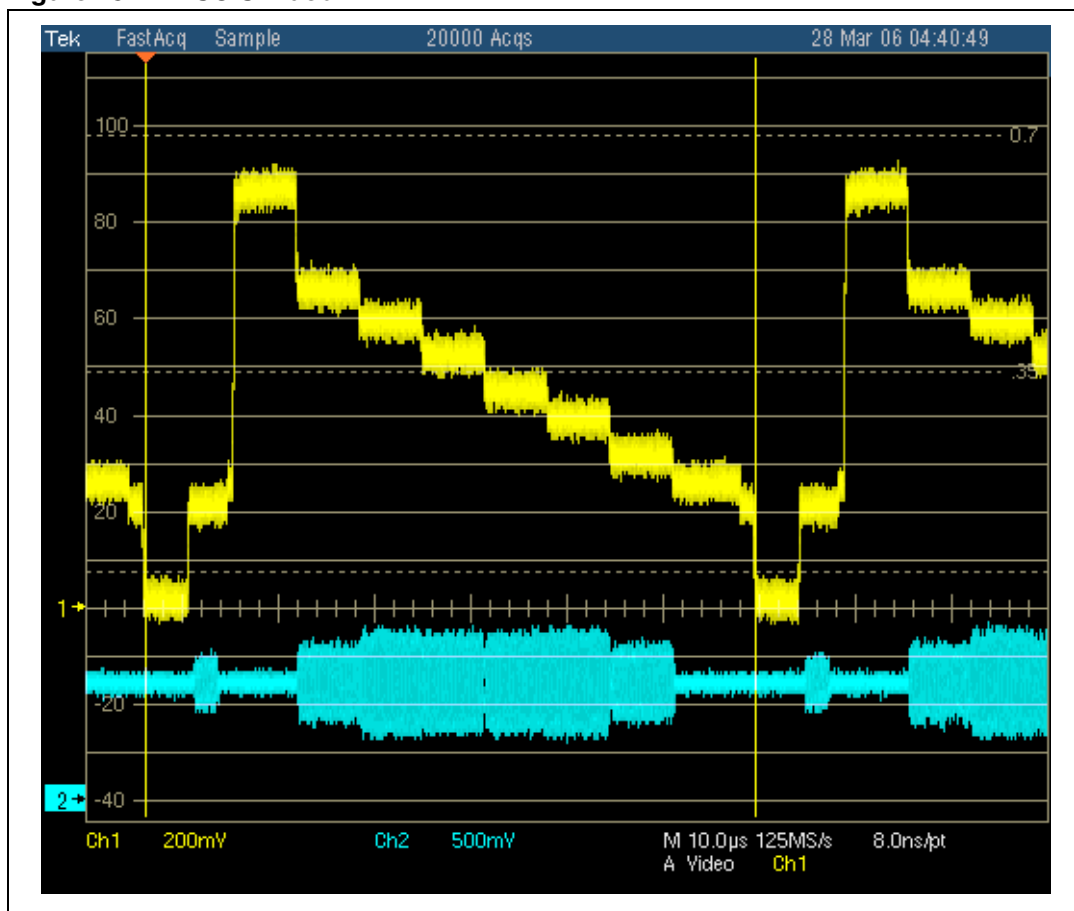

Figure 26. PAL composite

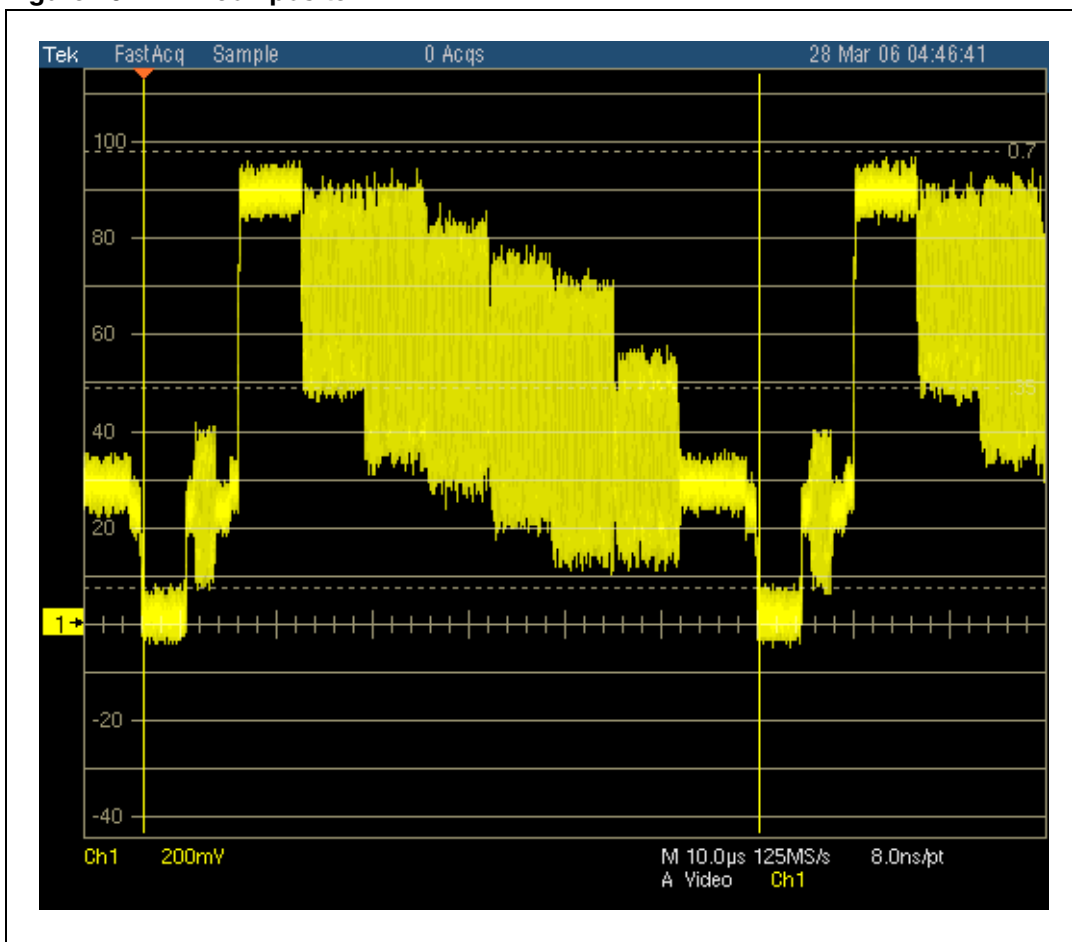
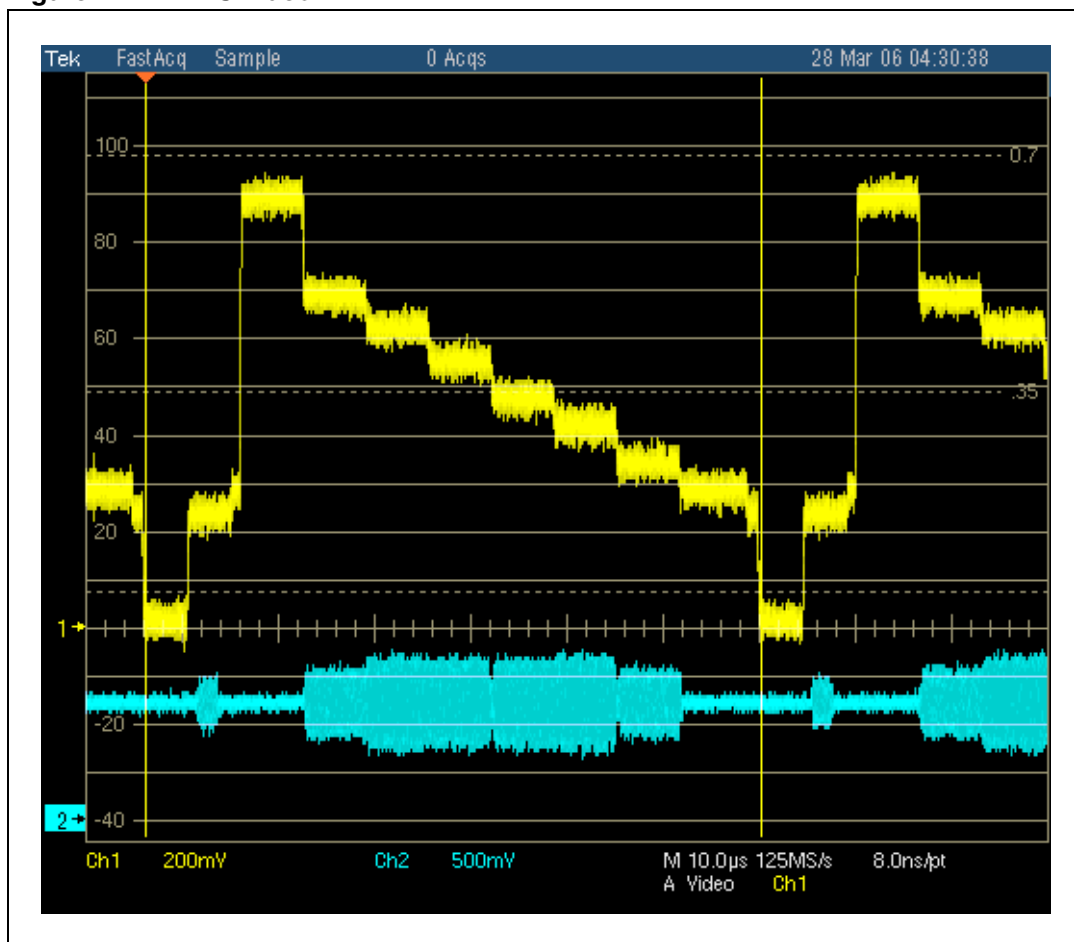

Figure 27. PAL S-video



10 Package mechanical data

10.1 TFBGA 49 balls

Table 29. TFBGA 4x4x1.2 mm

Dimensions (mm)			
Reference	Min	Typ	Max
A			1.2
A1	0.15		
A2		0.8	
A3		0.2	
A4			0.6
b	0.25	0.3	0.35
D	3.85	4.00	4.15
D1		3.00	
E	3.85	4.00	4.15
E1		3.00	
e		0.50	
F		0.5	
ddd			0.08
eee			0.15
fff			0.05

Figure 28. TFBGA 49 balls 4 x 4 x 1.2 mm body size

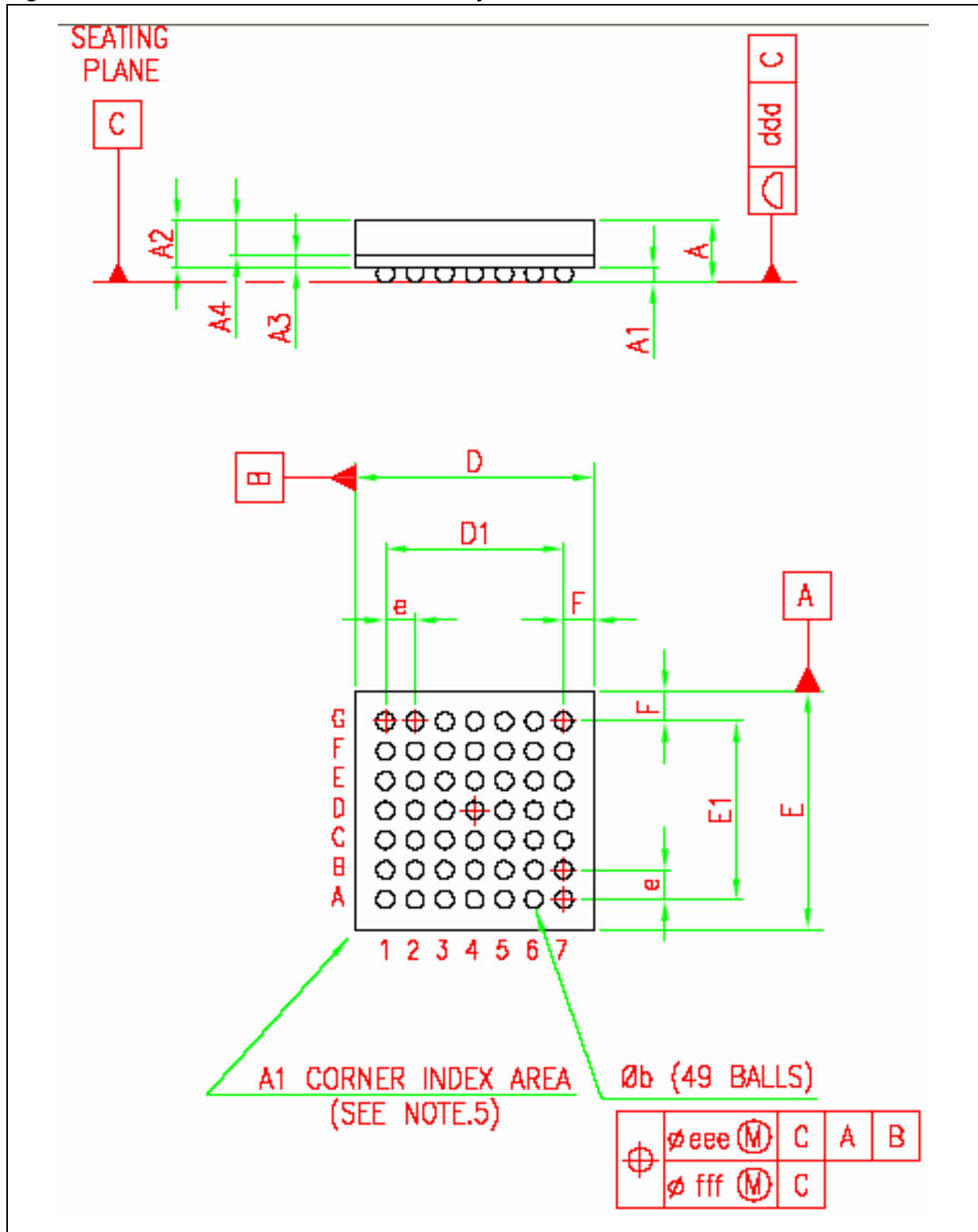

10.2 VFBGA 49 balls

Table 30. VFBGA 3x3x1.0 mm - 49 balls - Pitch 0.4 ball 0.25

Dimensions (mm)			
Reference	Min	Typ	Max
A ⁽¹⁾			1.00
A1	0.125		
A2		0.615	
A3		0.18	
A4			0.45
b ⁽²⁾	0.22	0.26	0.30
D	2.95	3.00	3.05
D1		2.40	
E	2.95	3.00	3.05
E1		2.40	
e		0.40	
F		0.30	
ddd			0.08
eee ⁽³⁾			0.13
fff ⁽⁴⁾			0.04

- VFBGA stands for **V**ery thin profile **F**ine pitch **B**all **G**rid **A**rray.
 Very thin profile: 0.80mm<A<=1.00mm/Fine pitch: e<1.00mm
 The maximum total package height is calculated by the following methodology

$$A2Typ + A1Typ + \left(\sqrt{A1^2 + A3^2 + A4^2} \text{tolerance values} \right)$$

- The typical ball diameter before mounting is 0.25mm
- VFBGA with 0.40mm ball pitch is not yet registered in JEDEC publications.
- The tolerance of position that controls the location of the balls with respect to datum A and B. For each ball there is a cylindrical tolerance zone eee perpendicular to datum C and located on true position with respect to datum A and B as defined by e. The axis perpendicular to datum C of each ball must lie within this tolerance zone.
 The tolerance of position that controls the location of the balls within the matrix with respect to each other. For each ball there is a cylindrical tolerance zone fff perpendicular to datum C and located on true position as defined by e. The axis perpendicular to datum C of each ball must lie within this tolerance zone. Each tolerance zone fff in the array is contained entirely in the respective zone eee above.
 The axis of each ball must lie simultaneously in both tolerance zones.

Figure 29. VFBGA 49 balls 3 x 3 x 1.0 mm body size

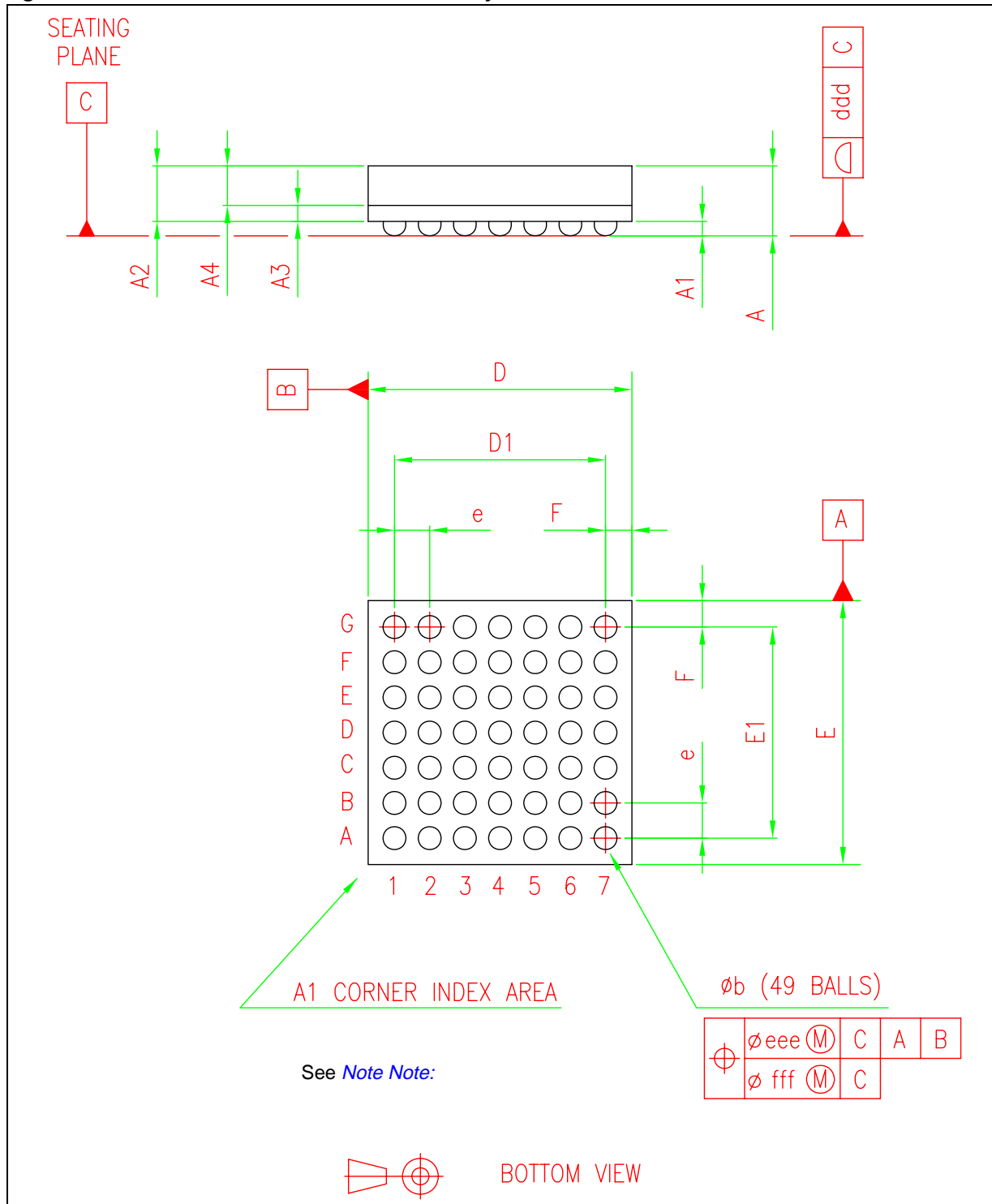

Note: The terminal A1 corner must be identified on the top surface by using a corner chamfer, ink or metallized markings, or other feature of package body or integral heatslug. A distinguishing feature is allowable on the bottom surface of the package to identify the terminal A1 corner. Exact shape of each corner is optional.

11 Ordering information

Table 31. Order codes

Part number	Package	Packing
STW8009B27R/LF	TFBGA49 4x4	Tray
STW8019B27R/LF	TFBGA49 4x4	Tray
STW8009B27T/LF	TFBGA49 4x4	Tape and reel
STW8019B27T/LF	TFBGA49 4x4	Tape and reel
STW8009BS3R/LF	VFBGA49 3x3	Tray
STW8019BS3R/LF	VFBGA49 3x3	Tray
STW8009BS3T/LF	VFBGA49 3x3	Tape and reel
STW8019BS3T/LF	VFBGA49 3x3	Tape and reel

12 Revision history

Table 32. Document revision history

Date	Revision	Changes
02-Feb-2006	1	Initial release.
08-Mar-2006	2	Correction in Table 18: dac12_conf on page 42
9-Jun-2006	3	<p>Added Section 4.5: Video timing.</p> <p>Corrected list of supported formats (NTSC-J, M).</p> <p>Updated Section 7.3: Electrical and timing characteristics.</p> <p>Added Chapter 9: Color test pattern waveforms.</p> <p>Reverted Dac 1 into Dac 2 and Dac 2 into Dac 1.</p> <p>Moved ordering information from the cover page to Chapter 11: Ordering information.</p> <p>Document status updated to final datasheet.</p>
08-Mar-2007	4	<p>Updated Tsg and Vesd values in Table 23: Absolute maximum ratings and added table footnotes about CDM and HBM test conditions.</p> <p>Added DiffG and DiffPh in Table 28: DAC & Video output characteristics / Rload = 37.5 ohm – F = 27 MHz – Rext = 2.4 kohm.</p> <p>Updated the definition of CDM (charge device model) in Table 23: Absolute maximum ratings.</p> <p>Removed reference to TQFP64 on cover page.</p>
21-Mar-2007	5	<p>Updated Figure 17: Mode transition diagram.</p> <p>Reviewed the text in paragraph “transition from off mode to sleep mode” in Section 4.13.2: Mode transition diagram.</p> <p>Updated “sleep mode” paragraph in Section 4.13.1: Operating modes.</p> <p>Added Table 22 and Figure 21 in Section 6.2: YcbCr bus.</p>
15-Jun-2007	6	Updated Section 4.10: Macrovision™ copy protection .

Please Read Carefully:

Information in this document is provided solely in connection with ST products. STMicroelectronics NV and its subsidiaries ("ST") reserve the right to make changes, corrections, modifications or improvements, to this document, and the products and services described herein at any time, without notice.

All ST products are sold pursuant to ST's terms and conditions of sale.

Purchasers are solely responsible for the choice, selection and use of the ST products and services described herein, and ST assumes no liability whatsoever relating to the choice, selection or use of the ST products and services described herein.

No license, express or implied, by estoppel or otherwise, to any intellectual property rights is granted under this document. If any part of this document refers to any third party products or services it shall not be deemed a license grant by ST for the use of such third party products or services, or any intellectual property contained therein or considered as a warranty covering the use in any manner whatsoever of such third party products or services or any intellectual property contained therein.

UNLESS OTHERWISE SET FORTH IN ST'S TERMS AND CONDITIONS OF SALE ST DISCLAIMS ANY EXPRESS OR IMPLIED WARRANTY WITH RESPECT TO THE USE AND/OR SALE OF ST PRODUCTS INCLUDING WITHOUT LIMITATION IMPLIED WARRANTIES OF MERCHANTABILITY, FITNESS FOR A PARTICULAR PURPOSE (AND THEIR EQUIVALENTS UNDER THE LAWS OF ANY JURISDICTION), OR INFRINGEMENT OF ANY PATENT, COPYRIGHT OR OTHER INTELLECTUAL PROPERTY RIGHT.

UNLESS EXPRESSLY APPROVED IN WRITING BY AN AUTHORIZED ST REPRESENTATIVE, ST PRODUCTS ARE NOT RECOMMENDED, AUTHORIZED OR WARRANTED FOR USE IN MILITARY, AIR CRAFT, SPACE, LIFE SAVING, OR LIFE SUSTAINING APPLICATIONS, NOR IN PRODUCTS OR SYSTEMS WHERE FAILURE OR MALFUNCTION MAY RESULT IN PERSONAL INJURY, DEATH, OR SEVERE PROPERTY OR ENVIRONMENTAL DAMAGE. ST PRODUCTS WHICH ARE NOT SPECIFIED AS "AUTOMOTIVE GRADE" MAY ONLY BE USED IN AUTOMOTIVE APPLICATIONS AT USER'S OWN RISK.

Resale of ST products with provisions different from the statements and/or technical features set forth in this document shall immediately void any warranty granted by ST for the ST product or service described herein and shall not create or extend in any manner whatsoever, any liability of ST.

ST and the ST logo are trademarks or registered trademarks of ST in various countries.

Information in this document supersedes and replaces all information previously supplied.

The ST logo is a registered trademark of STMicroelectronics. All other names are the property of their respective owners.

© 2007 STMicroelectronics - All rights reserved

STMicroelectronics group of companies

Australia - Belgium - Brazil - Canada - China - Czech Republic - Finland - France - Germany - Hong Kong - India - Israel - Italy - Japan - Malaysia - Malta - Morocco - Singapore - Spain - Sweden - Switzerland - United Kingdom - United States of America

www.st.com

