



2SC3356

NPN SILICON TRANSISTOR

HIGH FREQUENCY LOW NOISE AMPLIFIER

DESCRIPTION

The UTC **2SC3356** is designed for such applications as: DC/DC converters, supply line switching, battery charger, LCD backlighting, peripheral drivers, Driver in low supply voltage applications (e.g. lamps and LEDs) and inductive load driver (e.g. relays, buzzers and motors).

FEATURES

- * Low Noise and High Gain
- * High Power Gain

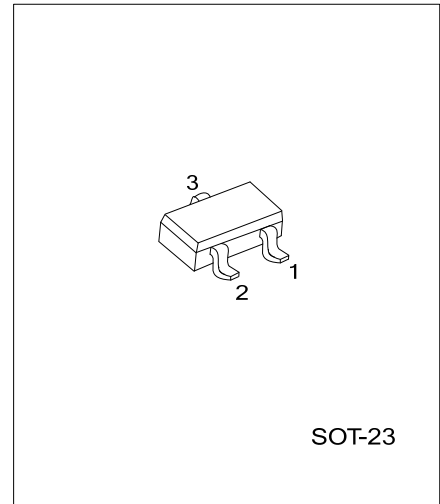

ORDERING INFORMATION

| Ordering Number | | | Package | Pin Description | | | Packing |
|-----------------|-------------------|------------------|---------|-----------------|---|---|-----------|
| Normal | Lead Free Plating | Halogen Free | | 1 | 2 | 3 | |
| 2SC3356-x-AE3-R | 2SC3356L-x-AE3-R | 2SC3356G-x-AE3-R | SOT-23 | E | B | C | Tape Reel |

| | |
|--|--|
| <p>2SC3356L-x-AE3-R</p> <p>(1) Packing Type (2) Package Type (3) Rank (4) Lead Plating</p> | <p>(1) R: Tape Reel (2) AE3: SOT-23 (3) x: refer to Classification of h_{FE} (4) G: Halogen Free, L: Lead Free, Blank: Pb/Sn</p> |
|--|--|

MARKING

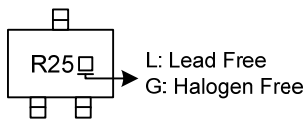

■ ABSOLUTE MAXIMUM RATING

| PARAMETER | SYMBOL | RATINGS | UNIT |
|------------------------------|------------|-----------|------|
| Collector to Base Voltage | BV_{CBO} | 20 | V |
| Collector to Emitter Voltage | BV_{CEO} | 12 | V |
| Emitter to Base Voltage | BV_{EBO} | 3 | V |
| Collector Current | I_C | 100 | mA |
| Power Dissipation | P_D | 200 | mW |
| Junction Temperature | T_J | 150 | °C |
| Storage Temperature | T_{STG} | -65~ +150 | °C |

Notes: Absolute maximum ratings are those values beyond which the device could be permanently damaged.

Absolute maximum ratings are stress ratings only and functional device operation is not implied.

■ ELECTRICAL CHARACTERISTICS ($T_a=25^\circ\text{C}$, unless otherwise specified)

| PARAMETER | SYMBOL | TEST CONDITIONS | MIN | TYP | MAX | UNIT |
|--------------------------------|-----------|---|-----|-----|-----|---------------|
| Collector-Base Cut-Off Current | I_{CBO} | $V_{CB}=10\text{ V}, I_E=0$ | | | 1.0 | μA |
| Emitter-Base Cut-Off Current | I_{EBO} | $V_{EB}=1\text{ V}, I_C=0$ | | | 1.0 | μA |
| DC Current Gain | h_{FE} | $V_{CE}=10\text{ V}, I_C=20\text{ mA}$ | 50 | | 300 | |
| Gain Bandwidth Product | f_T | $V_{CE}=10\text{ V}, I_C=20\text{ mA}$ | | 7 | | GHz |
| Feed-Back Capacitance | C_{RE} | $V_{CB}=10\text{ V}, I_E=0, f=1.0\text{MHz}$ | | | 1.0 | pF |
| Noise Figure | NF | $V_{CE}=10\text{ V}, I_C=7\text{mA}, f=1.0\text{GHz}$ | | | 2.0 | dB |

■ CLASSIFICATION OF h_{FE}

| RANK | A | B | C |
|-------|--------|---------|---------|
| RANGE | 50-160 | 160-240 | 240-300 |



2SC3356

NPN SILICON TRANSISTOR

TYPICAL CHARACTERISTICS

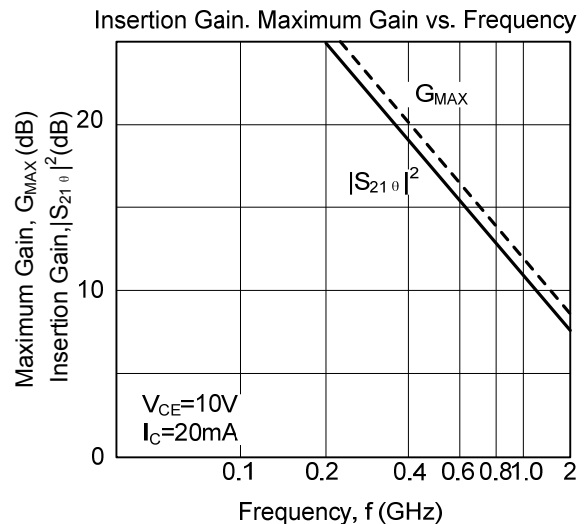
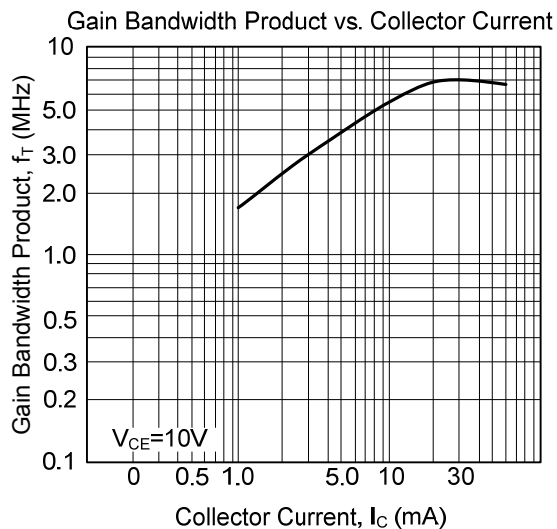
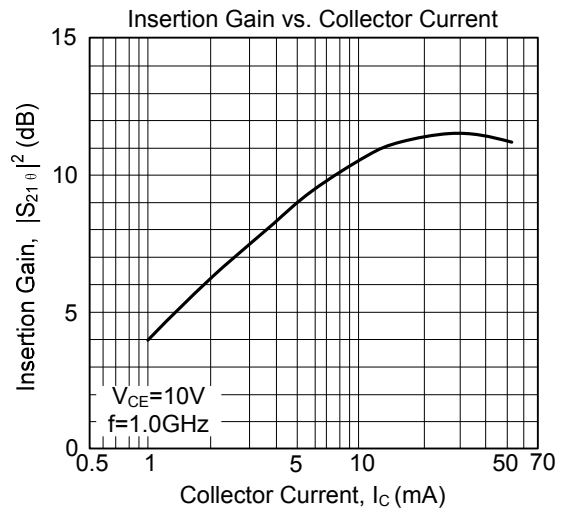
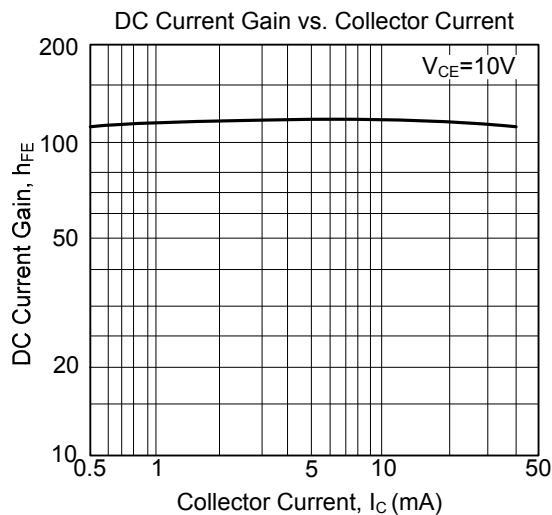
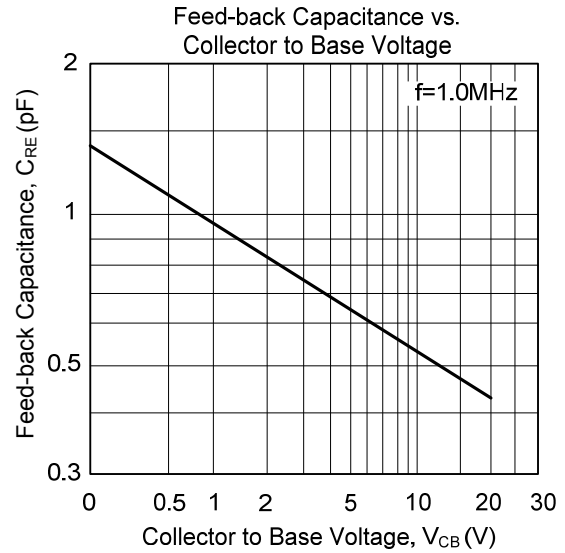
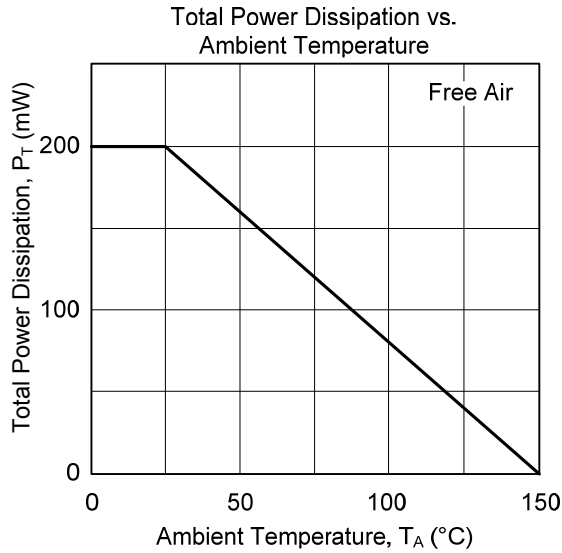



2SC3356

NPN SILICON TRANSISTOR

■ TYPICAL CHARACTERISTICS(Cont.)

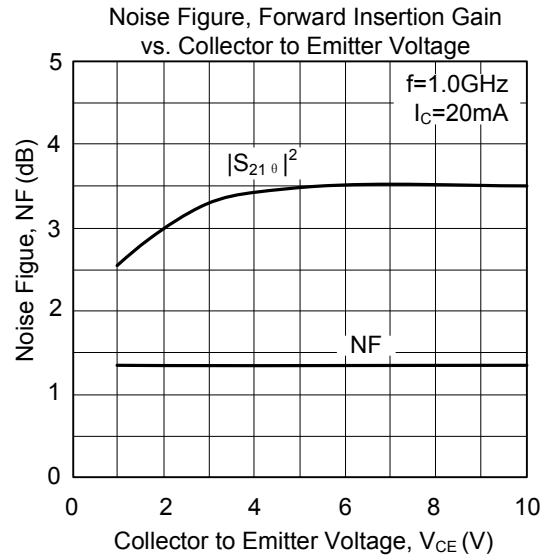
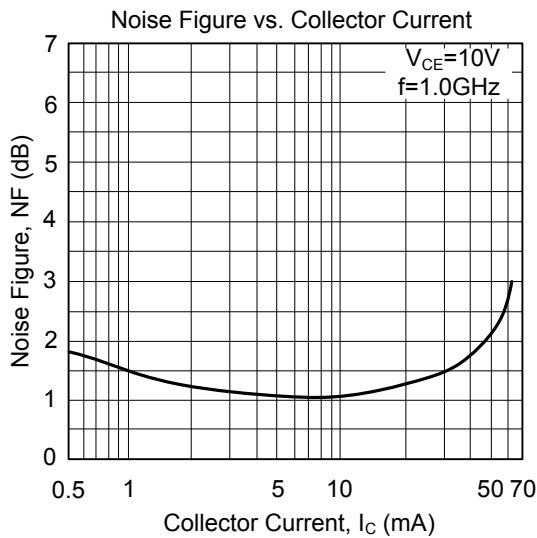

UTC assumes no responsibility for equipment failures that result from using products at values that exceed, even momentarily, rated values (such as maximum ratings, operating condition ranges, or other parameters) listed in products specifications of any and all UTC products described or contained herein. UTC products are not designed for use in life support appliances, devices or systems where malfunction of these products can be reasonably expected to result in personal injury. Reproduction in whole or in part is prohibited without the prior written consent of the copyright owner. The information presented in this document does not form part of any quotation or contract, is believed to be accurate and reliable and may be changed without notice.