

c

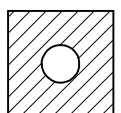

1 2 3 4

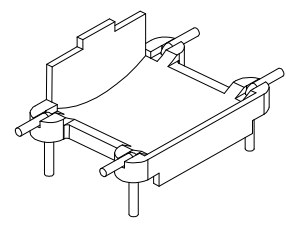
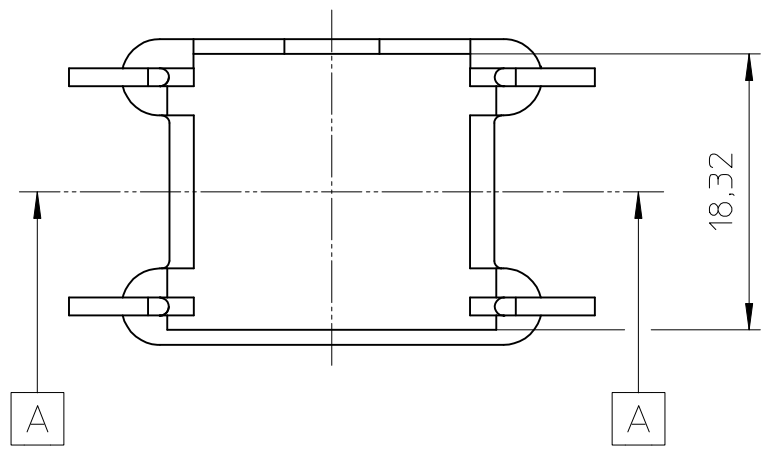
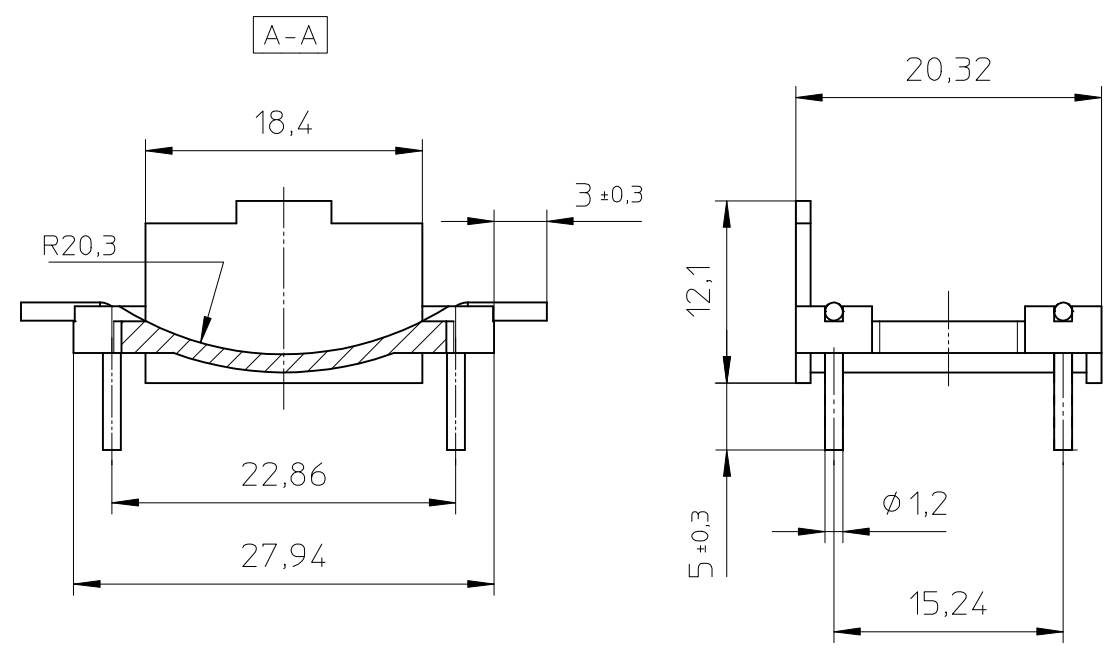

Coil former material: 1403G3 (PBT), glass-reinforced
 UL file number: E130155 - UL94V-0.
 Pin material: Copper-plated steel wire, Sn plated.
 Max. operating temp.: acc. to IEC 60 085 130°C.
 Resistance to soldering heat: acc. to IEC 60 068-2-20 Part 2, Test Tb, method 1B, 350°C-3,5s
 Solderability: acc. to IEC 60 068-2-20 Part 2, Test Ta, method 1, 235°C-2s

CLASS.NO.			07-02-20
TGP-40-4PD-Z		4322 021 06691	
NAME NAAM	SUPERS. VERV.	1 SH BL	SH BL
MPA	CHECK CONTR.	DAT. 07-02-20	Property of Eigendom van
		© FERROXCUBE 2007	112 - 001 010 A4

