



AS2930

150 mA Low Dropout Voltage Regulator

FEATURES

- Output Current in Excess of 150mA
- 3V, 3.3V, 3.5V, 4.0V, 4.5V & 5.0V Versions Available
- Very Low Quiescent Current
- Input-Output Differential Less than 0.6V
- 60V Load Dump Protection
- -50V Reverse Transient Protection
- Internal Thermal Overload Protection
- Reverse Battery Protection
- Short Circuit Protection
- Available in TO-220, TO-92, SO-8, SOT-89 Packages
- Similar to Industry Standard LM2930

APPLICATIONS

- Cordless Telephones
- Portable Consumer Equipment
- Portable Instrumentation
- Radio Control Systems

PRODUCT DESCRIPTION

The AS2930 is a positive Low Power Voltage Regulator. This device is an excellent choice for use in battery-powered applications, such as cordless telephones, radio control systems, and automotive applications. The AS2930 was originally designed for automotive applications, all circuitry is protected from reverse battery installations. During line transients, such as a load dump (+60V) when the input voltage to the regulator exceed its maximum operating voltage, this device will automatically shut down to protect both internal circuits as well as the load. The AS2930 is offered as a 3.0V, 3.3V, 3.5V, 4.5V, 5.0V fixed output in 3-pin SOT-89, TO-92/TO-220 packages compatible with other 5V regulators and TO-220/TO-92. The AS2930 is also offered in 5V SO-8 package.

ORDERING INFORMATION

TO-92 3-PIN	SO-8	SOT-89 3-PIN	TO-220	Oper. Temp. Range
AS2930N-X	AS2930S-X	AS2930M1-X	AS2930U-X	IND.
	AS2930CS-X		AS2930CU-X	IND.

X= Output Voltage (X = 3.0V, 3.3V, 3.5V, 4.0V, 4.5V & 5.0V)
For other fixed voltages consult factory.

PIN CONNECTIONS

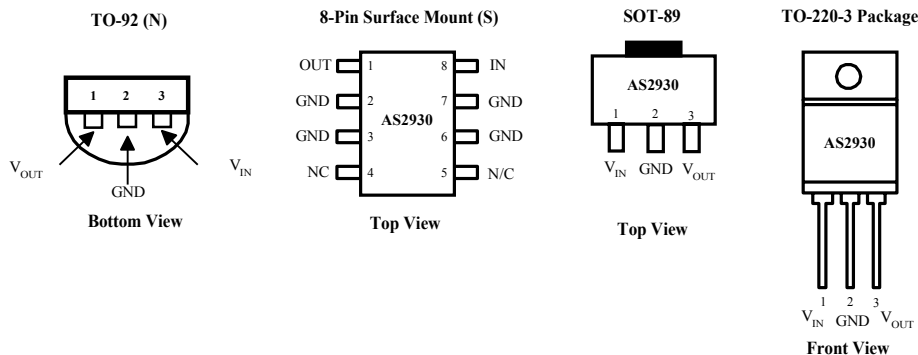

ABSOLUTE MAXIMUM RATINGS

Power Dissipation.....	Internally Limited
Lead Temp. (soldering, 10 Seconds).....	230°C
Storage Temperature Range	-65° to +150°C
Operating Junction Temperature Range	-40° to +85°C
Maximum Junction Temperature	+125°C
ESD Rating.....	2KV

Over Voltage Protection.....	60V
Reverse Voltage (100mS).....	-50V
Reverse Voltage(DC).....	-15V
Input Supply Voltage	-0.3 to +26V

ELECTRICAL CHARACTERISTICS at $V_s=14V$, $T_a=25^\circ C$, $I_o=150mA$, $C_2=100\mu F$, unless otherwise specified.

Parameter	Conditions	AS2930A			AS2930			Units
		Min	Typ	Max	Min	Typ	Max	
3.0 Volt Version		AS2930A-3			AS2930-3			
Output Voltage	$6V < V_{in} < 26V$, $I_o = 150mA$ Over Temp.	2.94	3.00	3.06	2.91	3.00	3.09	V
		2.88	3.00	3.12	2.85	3.00	3.15	V
3.3 Volt Version		AS2930A-3.3			AS2930-3.3			
Output Voltage	$6V < V_{in} < 26V$, $I_o = 150mA$ Over Temp.	3.23	3.30	3.36	3.20	3.30	3.39	V
		3.20	3.30	3.39	3.16	3.30	3.43	V
4.0 Volt Version		AS2930A-4.0			AS2930-4.0			
Output Voltage	$6V < V_{in} < 26V$, $I_o = 150mA$ Over Temp.	3.92	4.0	4.08	3.90	4.0	4.1	V
		3.90	4.0	4.1	3.86	4.0	4.14	V
5 Volt Version		AS2930A-5			AS2930-5			
Output Voltage	$6V < V_{in} < 26V$, $I_o = 150mA$ Over Temp.	4.81	5.00	5.19	4.75	5.00	5.25	V
		4.75		5.25	4.5		5.5	V
All Voltage Options								
Long Term Stability			20			20		mV/1000
Line Regulation	$9V < V_{in} < 16V$ $6V < V_{in} < 26V$		2.0 4.0	10 30		4.0 30		mV
Load Regulation	$5mA < I_o < 150mA$		14	50		14	50	mV
Dropout Voltage	$I_o = 10mA$ $I_o = 50mA$ $I_o = 150mA$		0.05	0.2		0.05	0.2	V
			0.07	0.1		0.07	0.1	V
			0.3	0.6		0.3	0.6	V
Quiescent Current	$I_o < 10mA$, $6V < V_{in} < 26V$ $-40^\circ C < T_j < 125^\circ C$ $I_o = 150mA$, $V_{in} = 14V$, $T_j = 25^\circ C$		0.4	1.0		0.4	1.0	mA
			15			15		mA
Maximum Operational Input Voltage		26	33		26	33		V
Maximum Line Transient	$R_L = 500\Omega$, $V_o < 5.5V$, 100ms	60	70		70	50		V
Reverse Polarity Input Voltage, DC	$V_o > -0.3V$, $R_L = 500\Omega$	-15	-30		-15	30		V
Reverse Polarity Input Voltage, Transient	1% Duty Cycle, $\tau < 100ms$, $R_L = 500\Omega$	-50	-80		-50	-80		V
Current Limit		150	400	450	150	400	450	mA
Output Noise Voltage	10Hz-100kHz, $C_{out} = 100\mu F$		500			500		μV_{rms}
Ripple Rejection	$f_o = 120Hz$		80			80		dB

TYPICAL CHARACTERISTICS

