

TOLERANCE UNLESS SPECIFIED = .XXX = +/- .005 .XX = +/- .015 FRACTIONS = +/- .032

# PRODUCTION TESTS

FS36-350.DC2

YYWW = YEAR, WEEK  
XXX = SITECODE

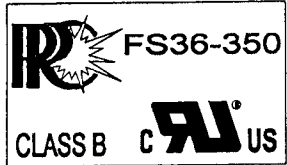

EIA-17-YYWW  
XXX B10

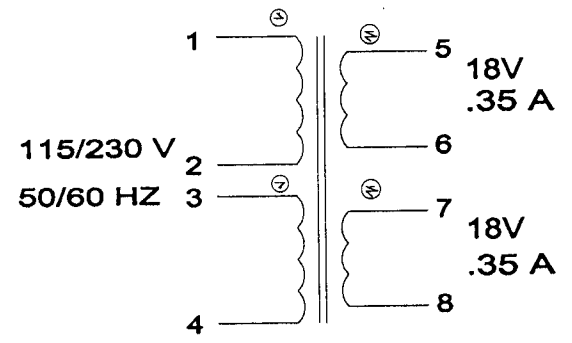
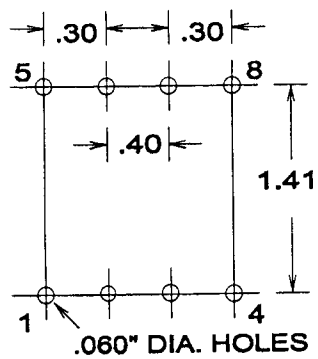
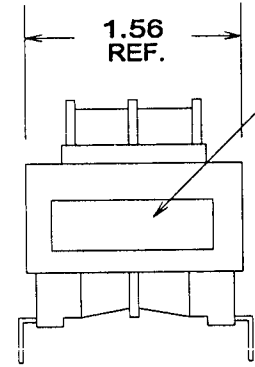
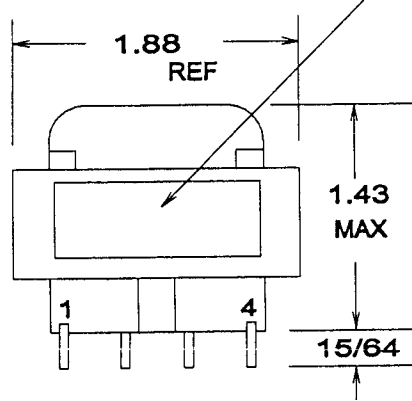

URNS RATIO = 100%

DC RESISTANCE IN OHMS	1-2 = 121 TO 149
	3-4 = 139 TO 170
	5-6 = 4.5 TO 5.5
	7-8 = 5.2 TO 6.4

MAX EXCITATION CURRENT = .020 A  
APPLY = 230V 60 HZ, 1-4, TIE 2+3

OPEN CIRCUIT VOLTAGE TEST:  
230V 60 HZ, 1-4, TIE 2+3  
1-2 = 3-4 = 115V  
EACH SEC = 21.6 TO 22.4 V

HIPOT: 2500V PRI'S TO SEC'S  
1500V PRI'S, SEC'S TO CORE  
500V P-P, S-S

IMPREGNATION NOTES = 2 HOUR PREHEAT  
PINS MUST BE FREE OF IMPREG.

## FINAL ASSEMBLY NOTES

METHOD 1 X 1

MARKING SEE LABEL DETAIL ABOVE

PART NO.: FS36-350