

PLEASE CHECK WWW.MOLEX.COM FOR LATEST PART INFORMATION

Part Number: [0039000224](#)
Status: **Active**
Overview: [minifit_jr](#)
Description: 4.20mm (.165") Pitch Mini-Fit™ Crimp Terminal, Male, Phosphor Bronze, Gold (Au), 16 AWG, Bag

Documents:

Test Summary (PDF)	Product Specification PS-5556-002 (PDF)
Drawing (PDF)	Product Specification PS-5556-003 (PDF)
Product Specification PS-5556-001 (PDF)	RoHS Certificate of Compliance (PDF)

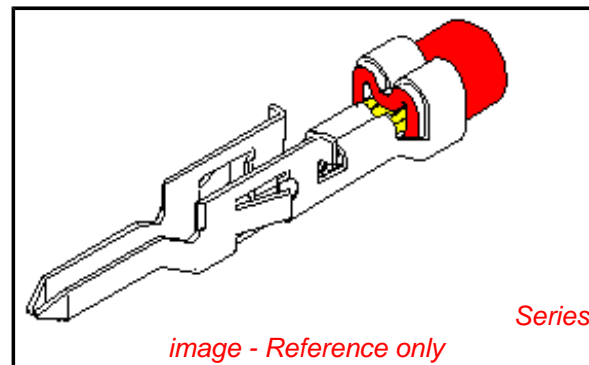

General

Product Family	Crimp Terminals
Series	5558
Crimp Quality Equipment	Yes
Overview	minifit_jr
Product Name	Mini-Fit®

Physical

Durability (mating cycles max)	30
Gender	Male
Material - Metal	Phosphor Bronze
Material - Plating Mating	Gold
Material - Plating Termination	Tin
Packaging Type	Bag
Termination Interface: Style	Crimp or Compression
Wire Insulation Diameter	1.80-3.10mm (.071-.122")
Wire Size AWG	16
Wire Size mm²	N/A

Electrical

Current - Maximum per Contact	9A
Voltage - Maximum	600V

Material Info

Old Part Number	5558PBGS3L
-----------------	------------

Reference - Drawing Numbers

Packaging Specification	PK-5556-003
Product Specification	PS-5556-001, PS-5556-002, PS-5556-003
Sales Drawing	SD-5558-002
Test Summary	TS-5556-002

EU RoHS

**ELV and RoHS
Compliant**
**REACH SVHC
Contains SVHC: No**
**Halogen-Free
Status**

China RoHS



**Need more information on product
environmental compliance?**

Email productcompliance@molex.com
 For a multiple part number RoHS Certificate of Compliance, [click here](#)

Please visit the [Contact Us](#) section for any non-product compliance questions.

Search Parts in this Series

[5558Series](#)

Mates With

[5556](#) Mini-Fit™ Crimp Terminal

Use With

[5559](#) Mini-Fit Jr.™ Plug Housing, [30068](#) Mini-Fit TPA™ Plug Housing, [42475](#) Mini-Fit BMI™ Plug Housing

Application Tooling | FAQ

Tooling specifications and manuals are found by selecting the products below. Crimp Height Specifications are then contained in the Application Tooling Specification document.

Global

Description	Product #
Extraction Tool	0011030044
Hand Crimp Tool for Mini-Fit™ Jr. Male and Female Crimp	0638190900

This document was generated on 06/01/2010

PLEASE CHECK WWW.MOLEX.COM FOR LATEST PART INFORMATION

10 9 8 7 6 5 4 3 2 1

NOTES

1. MATERIAL: SEE CHART
2. FINISH: SEE CHART
3. PRODUCT SPECIFICATION: PS-5556-001, PS-5556-002, PS-5556-003.
4. PACKAGING SPECIFICATION: PK-5558-001 FOR CHAIN
PK-5556-003 FOR LOOSE
5. MATES WITH TERMINAL: 5556 SERIES.
6. APPLICABLE HOUSING: 5559, 30068, 42475 SERIES.
7. THE NUMBER OF SERRATIONS TO BE ONE FOR WIRE RANGE #22-28.
8. WHEN TERMINALS ARE INSTALLED IN THE HOUSING THE WIRES ARE TO BE DRESSED IN SUCH A MANNER TO ALLOW THE TERMINALS TO FLOAT FREELY IN THE POCKET.
9. THIS TERMINAL IS DESIGNED FOR SINGLE WIRE CRIMPING.
10. PART CONFORMS TO CLASS "B" REQUIREMENTS OF COSMETIC SPECIFICATION PS-45499-002.

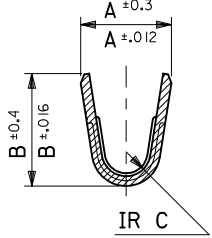
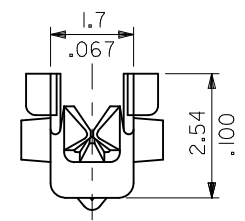
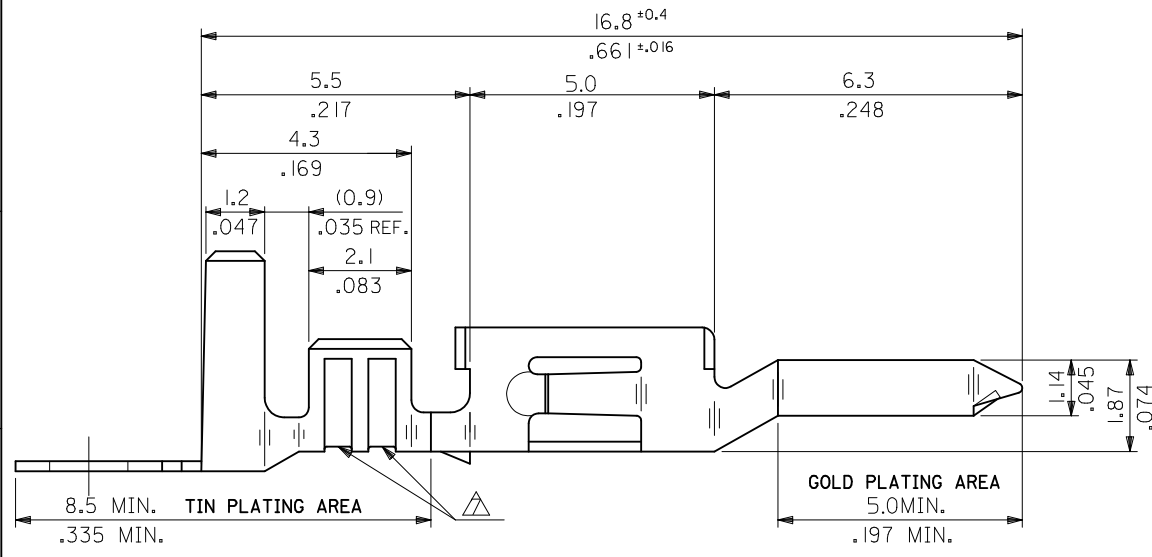
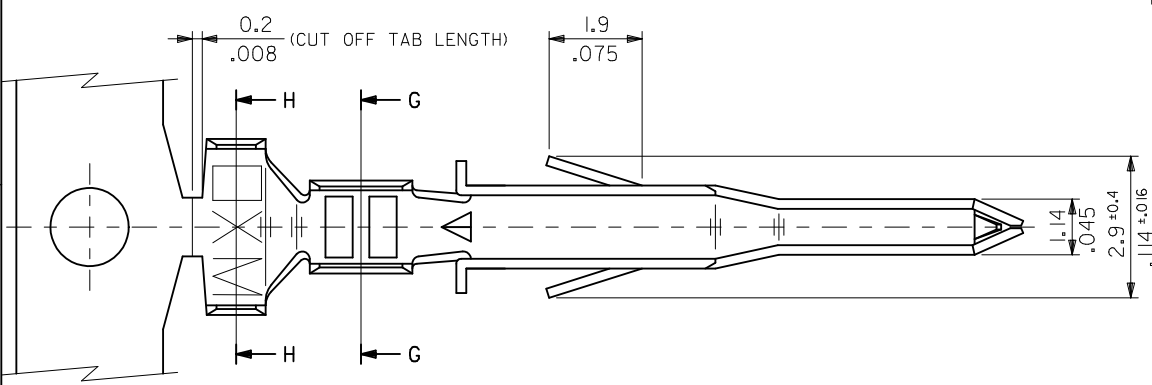

SECT. G-G

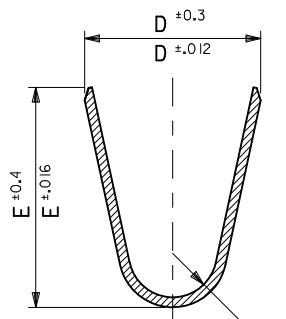

SECT. H-H

<p>UPDATE NOTES EC NO: UCP2010-2478 DRWN: J JAGUILAR 2010/04/06 CHKD: JBELL '92/05/21 APPR: FSMITH 2010/04/09</p>	<p>QUALITY SYMBOLS F7=0 F7=0 F7=0</p>	GENERAL TOLERANCES (UNLESS SPECIFIED)		DIMENSION STYLE	SCALE	DESIGN UNITS	THIRD ANGLE PROJECTION			
				MM/IN	10:1	METRIC				
				MM	INCH	DRAWN BY	DATE	TITLE		
				4 PLACES ± -- ± --	3 PLACES ± -- ± .008	2 PLACES ± 0.20 ± .008	1 PLACE ± 0.2 ± ---	ANGULAR ± 3 °	DRAWN BY H.HIRAMOTO '91/03/13	
		DRAFT WHERE APPLICABLE MUST REMAIN WITHIN DIMENSIONS		MATERIAL NO. SEE CHART		MATERIAL NO. SD-5558-002		SHEET NO. 1 OF 2		
				SIZE B		THIS DRAWING CONTAINS INFORMATION THAT IS PROPRIETARY TO MOLEX INCORPORATED AND SHOULD NOT BE USED WITHOUT WRITTEN PERMISSION				

9 8 7 6 5 4 3 2 1

PHOSPHOR BRONZE	SELECTIVE GOLD 0.76µm /30m.i. MIN. AND SELECTIVE TIN 2.03µm /80m.i. MIN. OVER NICKEL 1.27µm /50m.i. MIN.	0.9 .035	4.5 .177	3.6 .142	0.6 .024	2.7 .106	2.3 .091	∅ 3.1 .122 MAX.	# 16	39-00-0224	5558 PBGS3L	LOOSE
		0.6 .024	2.3 .091	2.3 .091	0.4 .016	1.65 .065	1.8 .071	∅ 0.9-1.8 .035-.071	#22-28	↑ -0223	↑ PBGS3	CHAIN
		0.6 .024	2.3 .091	2.3 .091	0.4 .016	1.65 .065	1.8 .071	∅ 0.9-1.8 .035-.071	#22-28	-0222	PBGS2L	LOOSE
		0.9 .035	4.5 .177	3.6 .142	0.5 .020	2.3 .091	1.9 .075	∅ 1.3-3.1 .051-.122	# 18-24	-0221	PBGS2	CHAIN
		0.9 .035	4.5 .177	3.6 .142	0.5 .020	2.3 .091	1.9 .075	∅ 1.3-3.1 .051-.122	# 18-24	-0220	PBGS1	LOOSE
		0.9 .035	4.5 .177	3.6 .142	0.5 .020	2.3 .091	1.9 .075	∅ 1.3-3.1 .051-.122	# 18-24	-0219	PBGS	CHAIN
		0.9 .035	4.5 .177	3.6 .142	0.6 .024	2.7 .106	2.3 .091	∅ 3.1 .122 MAX.	# 16	-0148	GS9L	LOOSE
		0.6 .024	2.3 .091	2.3 .091	0.4 .016	1.65 .065	1.8 .071	∅ 0.9-1.8 .035-.071	#22-28	↓ -0147	GS9	CHAIN
		0.6 .024	2.3 .091	2.3 .091	0.4 .016	1.65 .065	1.8 .071	∅ 0.9-1.8 .035-.071	#22-28	↓ -0146	GS8L	LOOSE
		0.9 .035	4.5 .177	3.6 .142	0.5 .020	2.3 .091	1.9 .075	∅ 1.3-3.1 .051-.122	# 18-24	39-00-0145	GS8	CHAIN
		0.9 .035	4.5 .177	3.6 .142	0.5 .020	2.3 .091	1.9 .075	∅ 1.3-3.1 .051-.122	# 18-24	40-13-0854	GS7L	LOOSE
		0.9 .035	4.5 .177	3.6 .142	0.5 .020	2.3 .091	1.9 .075	∅ 1.3-3.1 .051-.122	# 18-24	40-13-0853	GS7	CHAIN
BRASS	SELECTIVE GOLD 0.38µm /15m.i. MIN. AND SELECTIVE TIN 2.03µm /80m.i. MIN. OVER NICKEL 1.27µm /50m.i. MIN.	0.9 .035	4.5 .177	3.6 .142	0.6 .024	2.7 .106	2.3 .091	∅ 3.1 .122 MAX.	# 16	39-00-0100	GS6L	LOOSE
		0.6 .024	2.3 .091	2.3 .091	0.4 .016	1.65 .065	1.8 .071	∅ 0.9-1.8 .035-.071	#22-28	↑ -0099	GS6	CHAIN
		0.6 .024	2.3 .091	2.3 .091	0.4 .016	1.65 .065	1.8 .071	∅ 0.9-1.8 .035-.071	#22-28	-0098	GS5L	LOOSE
		0.6 .024	2.3 .091	2.3 .091	0.4 .016	1.65 .065	1.8 .071	∅ 0.9-1.8 .035-.071	#22-28	-0097	GS5	CHAIN
		0.9 .035	4.5 .177	3.6 .142	0.5 .020	2.3 .091	1.9 .075	∅ 1.3-3.1 .051-.122	# 18-24	-0076	GS4L	LOOSE
		0.9 .035	4.5 .177	3.6 .142	0.5 .020	2.3 .091	1.9 .075	∅ 1.3-3.1 .051-.122	# 18-24	-0075	GS4	CHAIN
	SELECTIVE GOLD 0.76µm /30m.i. MIN. AND SELECTIVE TIN 2.03µm /80m.i. MIN. OVER NICKEL 1.27µm /50m.i. MIN.	0.9 .035	4.5 .177	3.6 .142	0.6 .024	2.7 .106	2.3 .091	∅ 3.1 .122 MAX.	# 16	-0096	GS3L	LOOSE
		0.6 .024	2.3 .091	2.3 .091	0.4 .016	1.65 .065	1.8 .071	∅ 0.9-1.8 .035-.071	#22-28	-0095	GS3	CHAIN
		0.6 .024	2.3 .091	2.3 .091	0.4 .016	1.65 .065	1.8 .071	∅ 0.9-1.8 .035-.071	#22-28	-0433	GS2L7F	LOOSE
		0.6 .024	2.3 .091	2.3 .091	0.4 .016	1.65 .065	1.8 .071	∅ 0.9-1.8 .035-.071	#22-28	-0432	GS27F	CHAIN
		0.9 .035	4.5 .177	3.6 .142	0.5 .020	2.3 .091	1.9 .075	∅ 1.3-3.1 .051-.122	# 18-24	↓ -0431	↓ GSL7F	LOOSE
		0.9 .035	4.5 .177	3.6 .142	0.5 .020	2.3 .091	1.9 .075	∅ 1.3-3.1 .051-.122	# 18-24	39-00-0430	5558 GS7F	CHAIN
MATERIAL	FINISH	F	E	D	C	B	A	INS. RANGE	WIRE RANGE	EDP NO.	ENG NO.	FORM

UPDATE TITLE BLOCK EC NO: UCP2010-2478 DRWN: J JAGUILAR 2010/04/06 CHKD: JBELL '92/05/21 APPR: FSMITH 2010/04/09 REV E1	QUALITY SYMBOLS ∇=0 ∇=0 ∇=0	GENERAL TOLERANCES (UNLESS SPECIFIED)		DIMENSION STYLE		SCALE	DESIGN UNITS	THIRD ANGLE PROJECTION			
		mm		INCH		MM/IN		10:1	METRIC		
		DRAWN BY		DATE		DRAWN BY		DATE		TITLE	
		H.HIRAMOTO		'91/03/13		M.FUKUSHIMA		'92/05/21		MINI-FIT JR SELECT GOLD MALE CRIMP TERMINAL -LEAD FREE-	
CHECKED BY		DATE		APPROVED BY		DATE		MATERIAL NO.			
M.FUKUSHIMA		'92/05/21		FSMITH		2010/04/09		SEE CHART			
ANGULAR ± 3 °		DRAFT WHERE APPLICABLE MUST REMAIN WITHIN DIMENSIONS		MATERIAL NO.		DOCUMENT NO.		SHEET NO.			
						SD-5558-002		2 OF 2			
THIS DRAWING CONTAINS INFORMATION THAT IS PROPRIETARY TO MOLEX INCORPORATED AND SHOULD NOT BE USED WITHOUT WRITTEN PERMISSION											