



# DVHF2800S Series

## HIGH RELIABILITY HYBRID DC-DC CONVERTERS

### DESCRIPTION

The DVHF series of high reliability DC-DC converters is operable over the full military (-55 °C to +125 °C) temperature range with no power derating. Unique to the DVHF series is a magnetic feedback circuit that is radiation immune. Operating at a nominal fixed frequency of 450 kHz, these regulated, isolated units utilize well controlled undervoltage lockout circuitry to eliminate slow start-up problems.

These converters are designed and manufactured in a facility qualified to ISO9001 and certified to MIL-PRF-38534 and MIL-STD-883.

This product may incorporate one or more of the following U.S. patents:

5,784,266  
5,790,389  
5,963,438  
5,999,433  
6,005,780  
6,084,792  
6,118,673

### FEATURES

- High Reliability
- Very Low Output Noise
- Wide Input Voltage Range: 15 to 50 Volts per MIL-STD-704
- Up to 20 Watts Output Power
- Radiation Immune Magnetic Feedback Circuit
- NO Use of Optoisolators
- Undervoltage Lockout
- Indefinite Short Circuit Protection
- Current Limit Protection
- Industry Standard Pinout
- High Input Transient Voltage: 80 Volts for 1 sec per MIL-STD-704A
- Radiation Hardened Version Available
- Precision Projection Welded Hermetic Package
- High Power Density: > 37 W/in<sup>3</sup>
- Custom Versions Available
- Additional Environmental Screening Available
- Meets MIL-STD-461C and MIL-STD-461D EMC Requirements When Used With a DVMH28 EMI Filter
- Flanged and Non-flanged Versions Available.
- MIL-PRF-38534 Element Evaluated Components

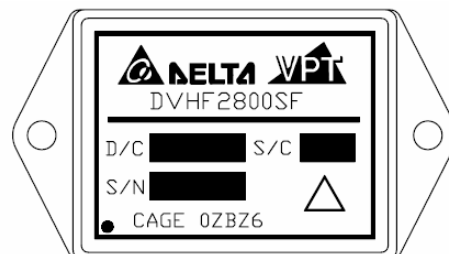


Figure 1 – DVHF2800S / DVHF2800SF DC-DC Converter  
(Not To Scale)

SPECIFICATIONS ( $T_{CASE} = -55^{\circ}\text{C}$  to  $+125^{\circ}\text{C}$ ,  $V_{IN} = +28\text{V} \pm 5\%$ , Full Load, Unless Otherwise Specified)

## ABSOLUTE MAXIMUM RATINGS

Input Voltage (Continuous)	50 $V_{DC}$	Junction Temperature Rise to Case	+12°C
Input Voltage (Transient, 1 second)	80 Volts	Storage Temperature	-65°C to +150°C
Output Power <sup>1</sup>	20 Watts	Lead Solder Temperature (10 seconds)	270°C
Power Dissipation (Full Load, $T_{CASE} = +125^{\circ}\text{C}$ )	6 Watts	Weight (Maximum) (Un-Flanged / Flanged)	(24 / 27) Grams

Parameter	Conditions	DVHF283R3S			DVHF2805S			Units
		Min	Typ	Max	Min	Typ	Max	
<b>STATIC</b>								
INPUT Voltage <sup>4</sup>	Continuous	15	28	50	15	28	50	V
	Transient, 1 sec	-	-	80	-	-	80	V
Current	Inhibited	-	-	6	-	-	6	mA
	No Load	-	40	65	-	40	65	mA
Ripple Current	Full Load, 20Hz to 10MHz	-	-	80	-	-	80	$\text{mA}_{p-p}$
Inhibit Pin Input <sup>4</sup>		0	-	1.5	0	-	1.5	V
Inhibit Pin Open Circuit Voltage <sup>4</sup>		9.0	11.0	13.0	9.0	11.0	13.0	V
UVLO Turn On		12.0	-	14.8	12.0	-	14.8	V
UVLO Turn Off <sup>4</sup>		11.0	-	14.5	11.0	-	14.5	V
OUTPUT Voltage	$V_{OUT}$ $T_{CASE} = 25^{\circ}\text{C}$	3.267	3.30	3.333	4.95	5.00	5.05	V
	$V_{OUT}$ $T_{CASE} = -55^{\circ}\text{C}$ to $+125^{\circ}\text{C}$	3.25	3.30	3.35	4.925	5.00	5.075	V
Power <sup>3</sup>		0	-	10	0	-	15	W
Current <sup>3</sup>	$V_{OUT}$	0	-	3.0	0	-	3.0	A
Ripple Voltage	$V_{OUT}$ Full Load, 20Hz to 10MHz	-	-	40	-	-	40	$\text{mV}_{p-p}$
Line Regulation	$V_{OUT}$ $V_{IN} = 15\text{V}$ to $50\text{V}$	-	-	20	-	-	20	mV
Load Regulation	$V_{OUT}$ No Load to Full Load	-	-	50	-	-	50	mV
EFFICIENCY		65	-	-	72	-	-	%
LOAD FAULT POWER DISSIPATION	Overload <sup>4</sup>	-	-	8	-	-	8	W
	Short Circuit	-	-	8	-	-	8	W
CAPACITIVE LOAD <sup>4</sup>		-	-	1000	-	-	1000	$\mu\text{F}$
SWITCHING FREQUENCY		350	450	500	350	450	500	kHz
ISOLATION	500 $V_{DC}$	100	-	-	100	-	-	M $\Omega$
MTBF (MIL-HDBK-217F)	AIF @ $T_c = 55^{\circ}\text{C}$	-	427	-	-	427	-	kHrs
<b>DYNAMIC</b>								
Load Step Output Transient	$V_{OUT}$ Half Load to Full Load	-	-	400	-	-	600	$\text{mV}_{PK}$
Load Step Recovery <sup>2</sup>		-	-	500	-	-	600	$\mu\text{Sec}$
Line Step Output Transient <sup>4</sup>	$V_{OUT}$ $V_{IN} = 16\text{V}$ to $40\text{V}$	-	400	700	-	400	800	$\text{mV}_{PK}$
Line Step Recovery <sup>2,4</sup>		-	300	500	-	300	700	$\mu\text{Sec}$
Turn On Delay	$V_{OUT}$ $V_{IN} = 0\text{V}$ to $28\text{V}$	-	10	20	-	10	20	mSec
Turn On Overshoot		-	0	15	-	0	25	$\text{mV}_{PK}$

Notes: 1. Dependant on output voltage. 2. Time for output voltage to settle within 1% of its nominal value.  
3. Derate linearly to 0 at 135°C. 4. Verified by qualification testing.

SPECIFICATIONS ( $T_{CASE} = -55^{\circ}\text{C}$  to  $+125^{\circ}\text{C}$ ,  $V_{IN} = +28\text{V} \pm 5\%$ , Full Load, Unless Otherwise Specified)

## ABSOLUTE MAXIMUM RATINGS

Input Voltage (Continuous)	50 $V_{DC}$	Junction Temperature Rise to Case	+12°C
Input Voltage (Transient, 1 second)	80 Volts	Storage Temperature	-65°C to +150°C
Output Power <sup>1</sup>	20 Watts	Lead Solder Temperature (10 seconds)	270°C
Power Dissipation (Full Load, $T_{CASE} = +125^{\circ}\text{C}$ )	6 Watts	Weight (Maximum) (Un-Flanged / Flanged)	(24 / 27) Grams

Parameter	Conditions	DVHF2812S			DVHF2815S			Units
		Min	Typ	Max	Min	Typ	Max	
<b>STATIC</b>								
INPUT Voltage <sup>4</sup>	Continuous	15	28	50	15	28	50	V
	Transient, 1 sec	-	-	80	-	-	80	V
Current	Inhibited	-	-	6	-	-	6	mA
	No Load	-	40	65	-	40	65	mA
Ripple Current	Full Load, 20Hz to 10MHz	-	-	80	-	-	80	$\text{mA}_{p-p}$
Inhibit Pin Input <sup>4</sup>		0	-	1.5	0	-	1.5	V
Inhibit Pin Open Circuit Voltage <sup>4</sup>		9.0	11.0	13.0	9.0	11.0	13.0	V
UVLO Turn On		12.0	-	14.8	12.0	-	14.8	V
UVLO Turn Off <sup>4</sup>		11.0	-	14.5	11.0	-	14.5	V
OUTPUT Voltage	$V_{OUT}$ $T_{CASE} = 25^{\circ}\text{C}$	11.88	12.0	12.12	14.85	15.0	15.15	V
	$V_{OUT}$ $T_{CASE} = -55^{\circ}\text{C}$ to $+125^{\circ}\text{C}$	11.82	12.0	12.18	14.775	15.0	15.225	V
Power <sup>3</sup>		0	-	20	0	-	20	W
Current <sup>3</sup>	$V_{OUT}$	0	-	1.67	0	-	1.34	A
Ripple Voltage	$V_{OUT}$ Full Load, 20Hz to 10MHz	-	-	40	-	-	40	$\text{mV}_{p-p}$
Line Regulation	$V_{OUT}$ $V_{IN} = 15\text{V}$ to $50\text{V}$	-	-	20	-	-	20	mV
Load Regulation	$V_{OUT}$ No Load to Full Load	-	-	50	-	-	50	mV
EFFICIENCY		77	-	-	78	-	-	%
LOAD FAULT POWER DISSIPATION	Overload <sup>4</sup>	-	-	8	-	-	8	W
	Short Circuit	-	-	8	-	-	8	W
CAPACITIVE LOAD <sup>4</sup>		-	-	500	-	-	500	$\mu\text{F}$
SWITCHING FREQUENCY		350	450	500	350	450	500	kHz
ISOLATION	500 $V_{DC}$	100	-	-	100	-	-	$\text{M}\Omega$
MTBF (MIL-HDBK-217F)	AIF @ $T_c = 55^{\circ}\text{C}$	-	427	-	-	427	-	kHrs
<b>DYNAMIC</b>								
Load Step Output Transient	$V_{OUT}$ Half Load to Full Load	-	-	500	-	-	500	$\text{mV}_{PK}$
Load Step Recovery <sup>2</sup>		-	-	500	-	-	500	$\mu\text{Sec}$
Line Step Output Transient <sup>4</sup>	$V_{OUT}$ $V_{IN} = 16\text{V}$ to $40\text{V}$	-	500	900	-	500	900	$\text{mV}_{PK}$
Line Step Recovery <sup>2,4</sup>		-	300	500	-	300	500	$\mu\text{Sec}$
Turn On Delay	$V_{OUT}$ $V_{IN} = 0\text{V}$ to $28\text{V}$	-	10	20	-	10	20	mSec
Turn On Overshoot		-	0	50	-	0	50	$\text{mV}_{PK}$

Notes: 1. Dependant on output voltage. 2. Time for output voltage to settle within 1% of its nominal value.  
3. Derate linearly to 0 at 135°C. 4. Verified by qualification testing.

SPECIFICATIONS ( $T_{CASE} = -55^{\circ}\text{C}$  to  $+125^{\circ}\text{C}$ ,  $V_{IN} = +28\text{V} \pm 5\%$ , Full Load, Unless Otherwise Specified)

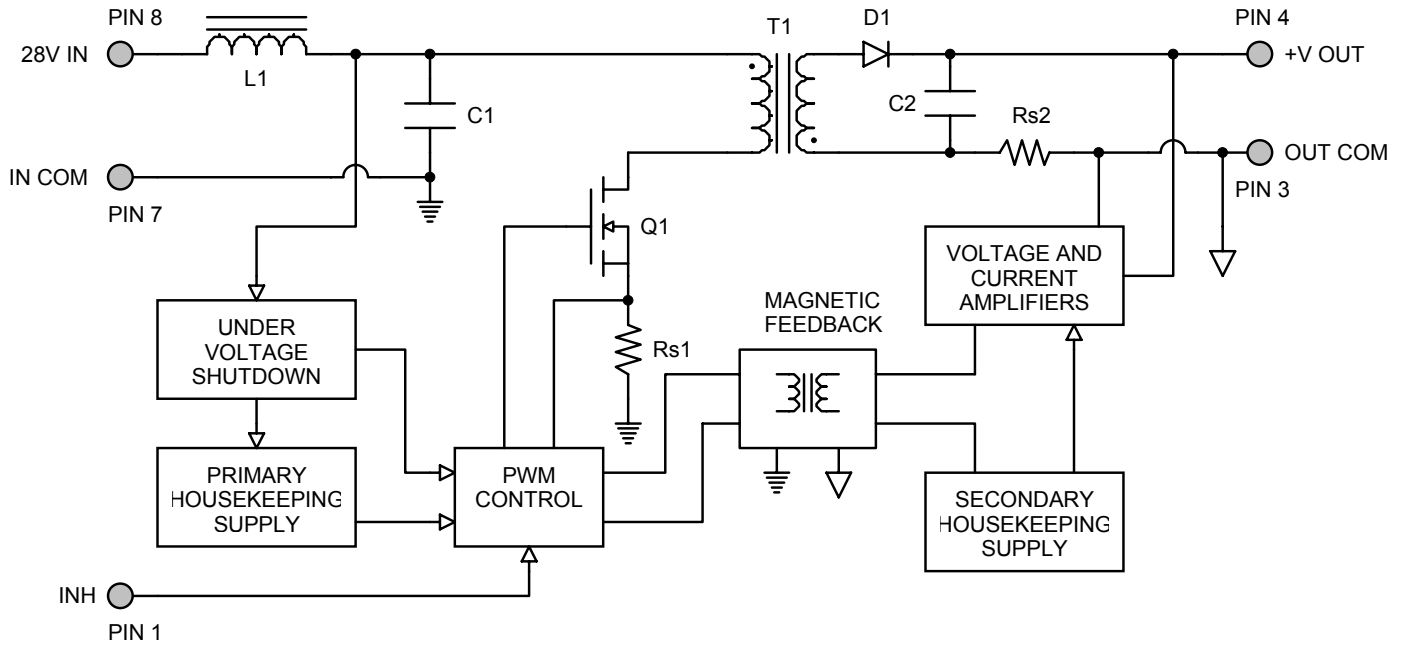
## ABSOLUTE MAXIMUM RATINGS

Input Voltage (Continuous)	50 $V_{DC}$	Junction Temperature Rise to Case	+12°C
Input Voltage (Transient, 1 second)	80 Volts	Storage Temperature	-65°C to +150°C
Output Power <sup>1</sup>	20 Watts	Lead Solder Temperature (10 seconds)	270°C
Power Dissipation (Full Load, $T_{CASE} = +125^{\circ}\text{C}$ )	6 Watts	Weight (Maximum) (Un-Flanged / Flanged)	(24 / 27) Grams

Parameter	Conditions	DVHF285R2S			DVHF281R9S			Units
		Min	Typ	Max	Min	Typ	Max	
<b>STATIC</b>								
INPUT Voltage <sup>4</sup>	Continuous	15	28	50	15	28	50	V
	Transient, 1 sec	-	-	80	-	-	80	V
Current	Inhibited	-	-	6	-	-	6	mA
	No Load	-	40	65	-	40	65	mA
Ripple Current	Full Load, 20Hz to 10MHz	-	-	80	-	-	80	$\text{mA}_{p-p}$
Inhibit Pin Input <sup>4</sup>		0	-	1.5	0	-	1.5	V
Inhibit Pin Open Circuit Voltage <sup>4</sup>		9.0	11.0	13.0	9.0	11.0	13.0	V
UVLO Turn On		12.0	-	14.8	12.0	-	14.8	V
UVLO Turn Off <sup>4</sup>		11.0	-	14.5	11.0	-	14.5	V
OUTPUT Voltage	$V_{OUT}$ $T_{CASE} = 25^{\circ}\text{C}$	5.148	5.20	5.252	1.87	1.90	1.93	V
	$V_{OUT}$ $T_{CASE} = -55^{\circ}\text{C}$ to $+125^{\circ}\text{C}$	5.122	5.20	5.278	1.86	1.90	1.94	V
Power <sup>3</sup>		0	-	15	0	-	8	W
Current <sup>3</sup>	$V_{OUT}$	0	-	3.0	0	-	4.0	A
Ripple Voltage	$V_{OUT}$ Full Load, 20Hz to 10MHz	-	-	40	-	-	40	$\text{mV}_{p-p}$
Line Regulation	$V_{OUT}$ $V_{IN} = 15\text{V}$ to $50\text{V}$	-	-	20	-	-	20	mV
Load Regulation	$V_{OUT}$ No Load to Full Load	-	-	50	-	-	50	mV
EFFICIENCY		72	-	-	59	-	-	%
LOAD FAULT POWER DISSIPATION	Overload <sup>4</sup>	-	-	8	-	-	8	W
	Short Circuit	-	-	8	-	-	8	W
CAPACITIVE LOAD <sup>4</sup>		-	-	1000	-	-	1000	$\mu\text{F}$
SWITCHING FREQUENCY		350	450	500	350	450	500	kHz
ISOLATION	500 $V_{DC}$	100	-	-	100	-	-	$\text{M}\Omega$
MTBF (MIL-HDBK-217F)	AIF @ $T_c = 55^{\circ}\text{C}$	-	427	-	-	427	-	kHrs
<b>DYNAMIC</b>								
Load Step Output Transient	$V_{OUT}$ Half Load to Full Load	-	-	600	-	-	250	$\text{mV}_{PK}$
Load Step Recovery <sup>2</sup>		-	-	600	-	-	600	$\mu\text{Sec}$
Line Step Output Transient <sup>4</sup>	$V_{OUT}$ $V_{IN} = 16\text{V}$ to $40\text{V}$	-	400	800	-	100	400	$\text{mV}_{PK}$
Line Step Recovery <sup>2,4</sup>		-	300	700	-	200	700	$\mu\text{Sec}$
Turn On Delay	$V_{OUT}$ $V_{IN} = 0\text{V}$ to $28\text{V}$	-	10	20	-	10	20	mSec
Turn On Overshoot		-	0	25	-	0	15	$\text{mV}_{PK}$

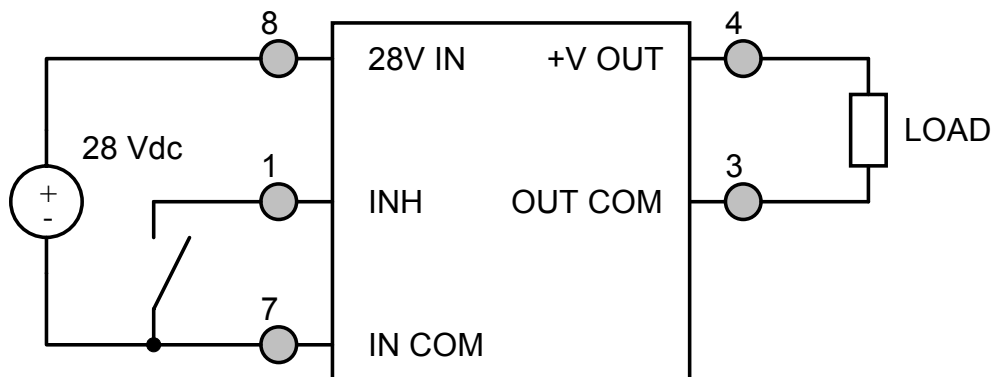
Notes: 1. Dependant on output voltage. 2. Time for output voltage to settle within 1% of its nominal value.  
3. Derate linearly to 0 at 135°C. 4. Verified by qualification testing.

**BLOCK DIAGRAM**



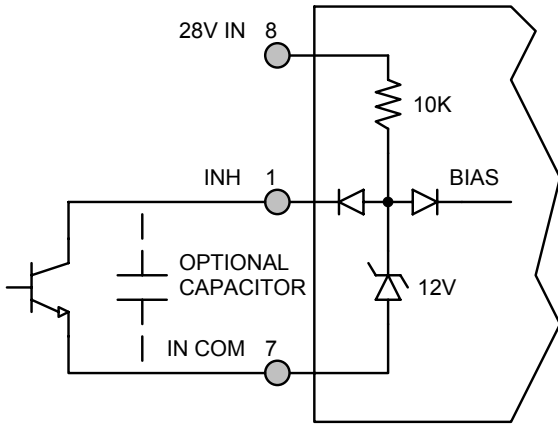
**Figure 2**

**CONNECTION DIAGRAM**

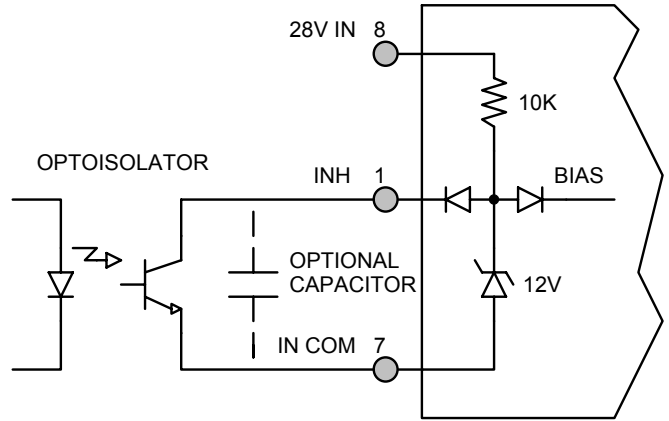


**Figure 3**

**INHIBIT DRIVE CONNECTION DIAGRAMS**

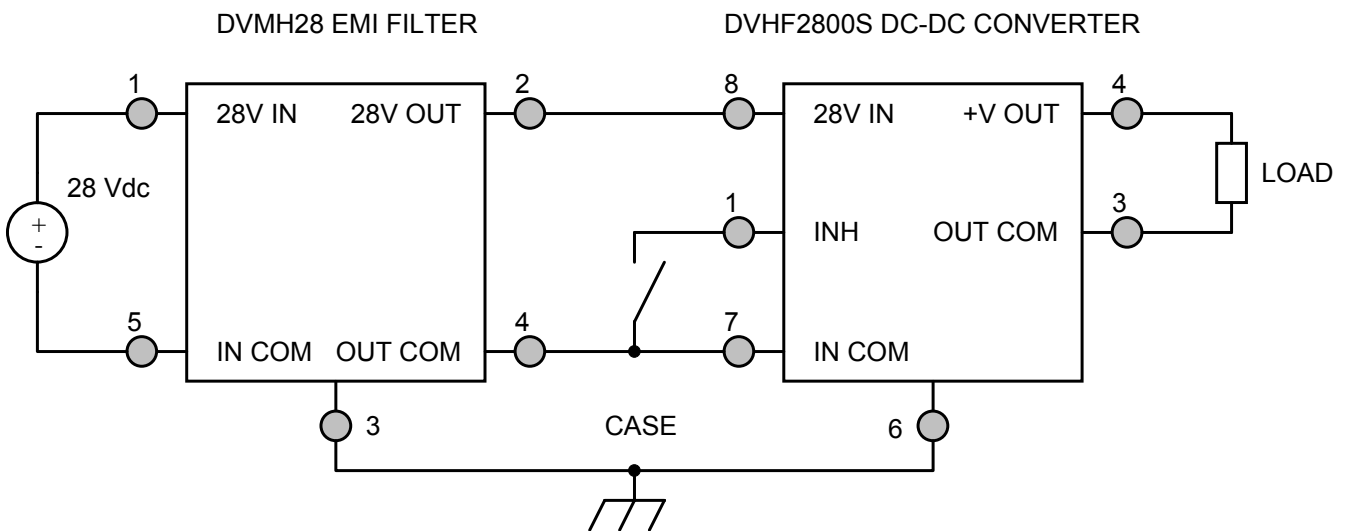


**Figure 4 – Internal Inhibit Circuit and Recommended Drive**  
(Shown with optional capacitor for turn-on delay)



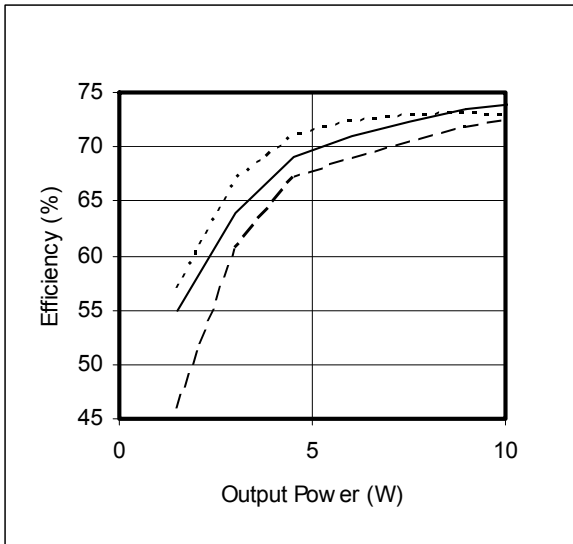
**Figure 5 – Isolated Inhibit Drive**  
(Shown with optional capacitor for turn-on delay)

**EMI FILTER HOOKUP DIAGRAM**

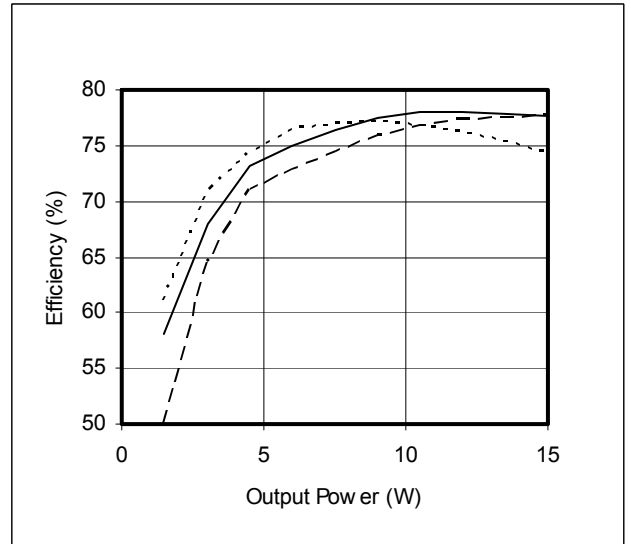


**Figure 6 – Converter with EMI Filter**

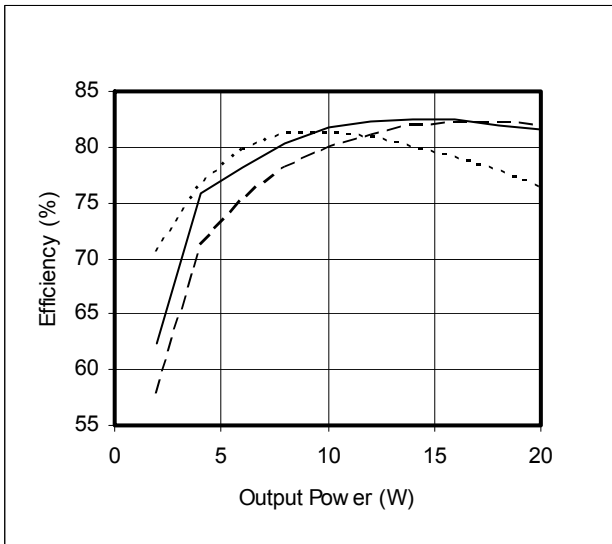
EFFICIENCY PERFORMANCE CURVES ( $T_{CASE} = 25^{\circ}C$ , Full Load, Unless Otherwise Specified)



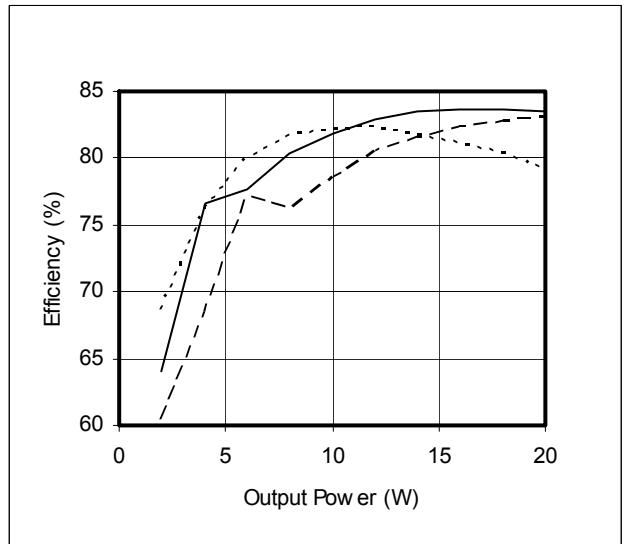
**Figure 7 – DVHF283R3S**  
Efficiency (%) vs. Output Power (W)



**Figure 8 – DVHF2805S / DVHF285R2S**  
Efficiency (%) vs. Output Power (W)



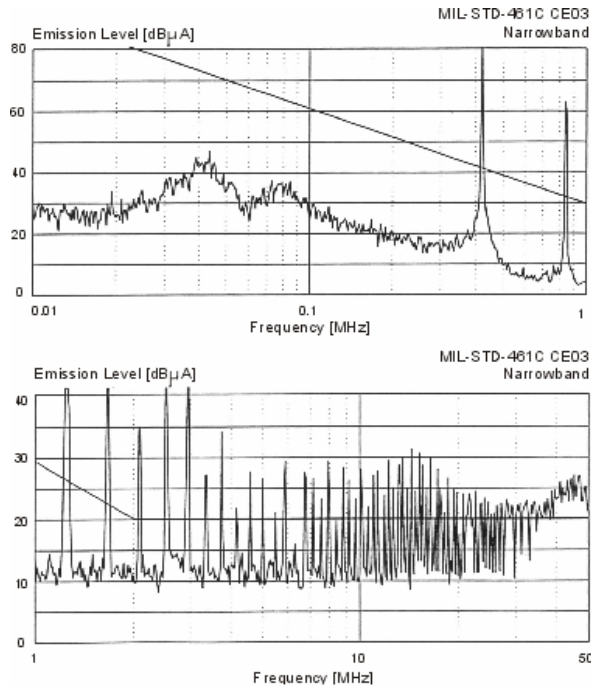
**Figure 9 – DVHF2812S**  
Efficiency (%) vs. Output Power (W)



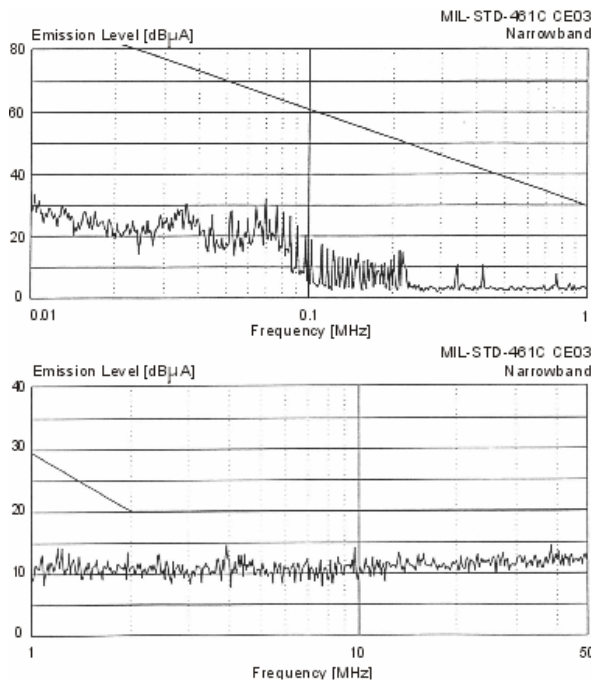
**Figure 10 – DVHF2815S**  
Efficiency (%) vs. Output Power (W)

**EMI PERFORMANCE CURVES**

( $T_{CASE} = 25^{\circ}C$ ,  $V_{IN} = +28V \pm 5\%$ , Full Load, Unless Otherwise Specified)



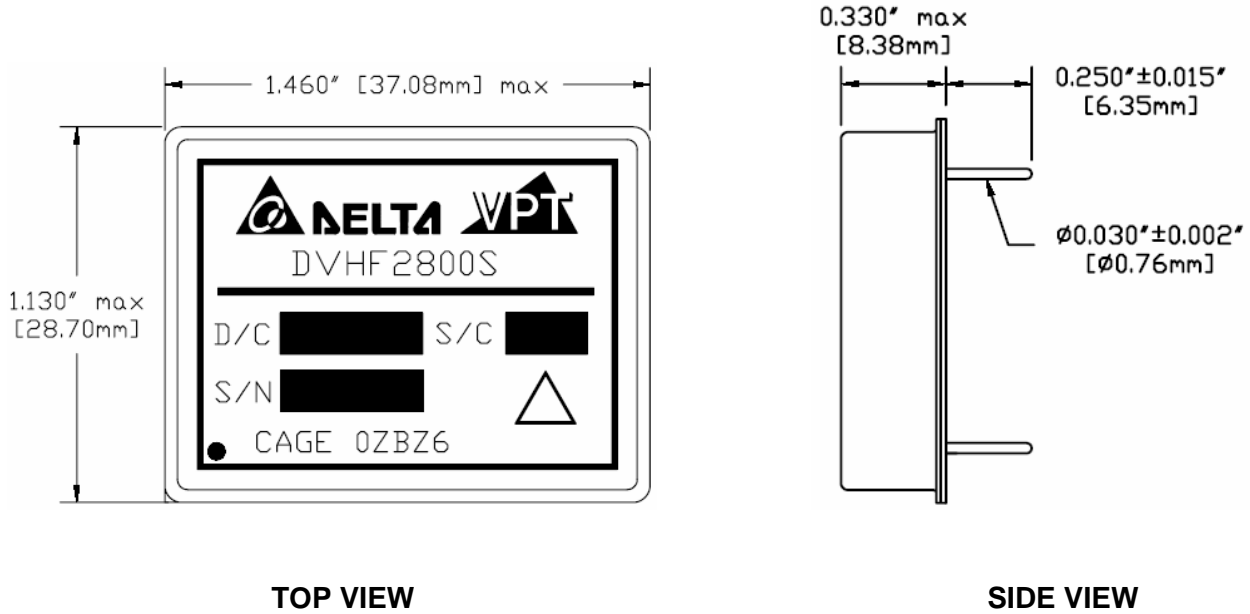
**Figure 11 – DVHF2800S without EMI Filter**



**Figure 12 – DVHF2800S with EMI Filter**

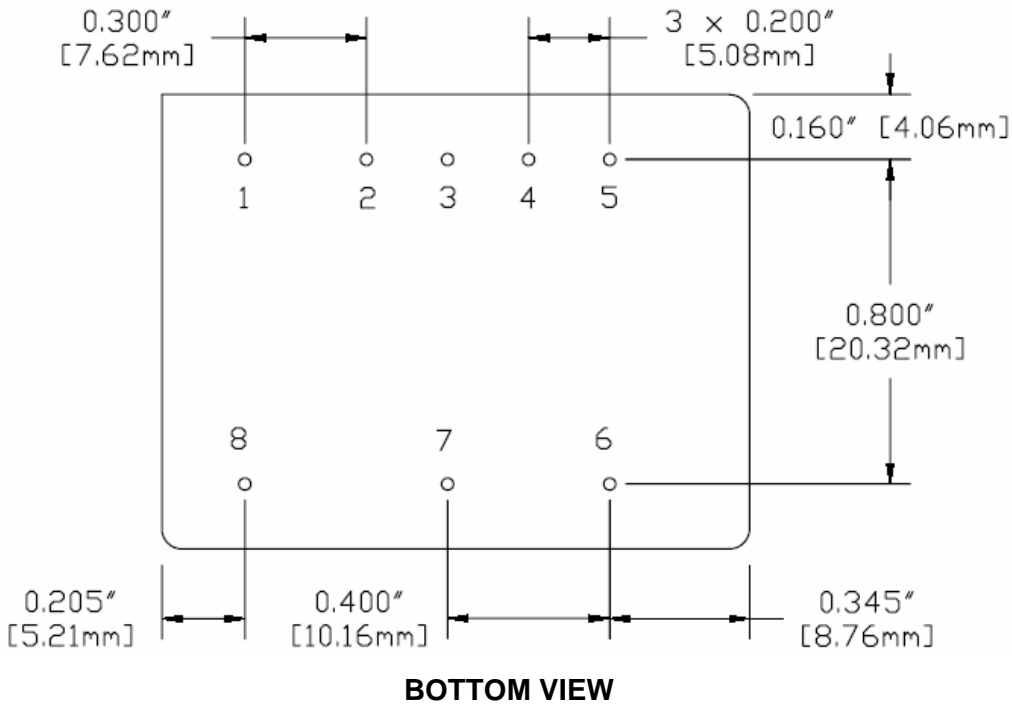


## PACKAGE SPECIFICATIONS (NON-FLANGED)



**TOP VIEW**

**SIDE VIEW**

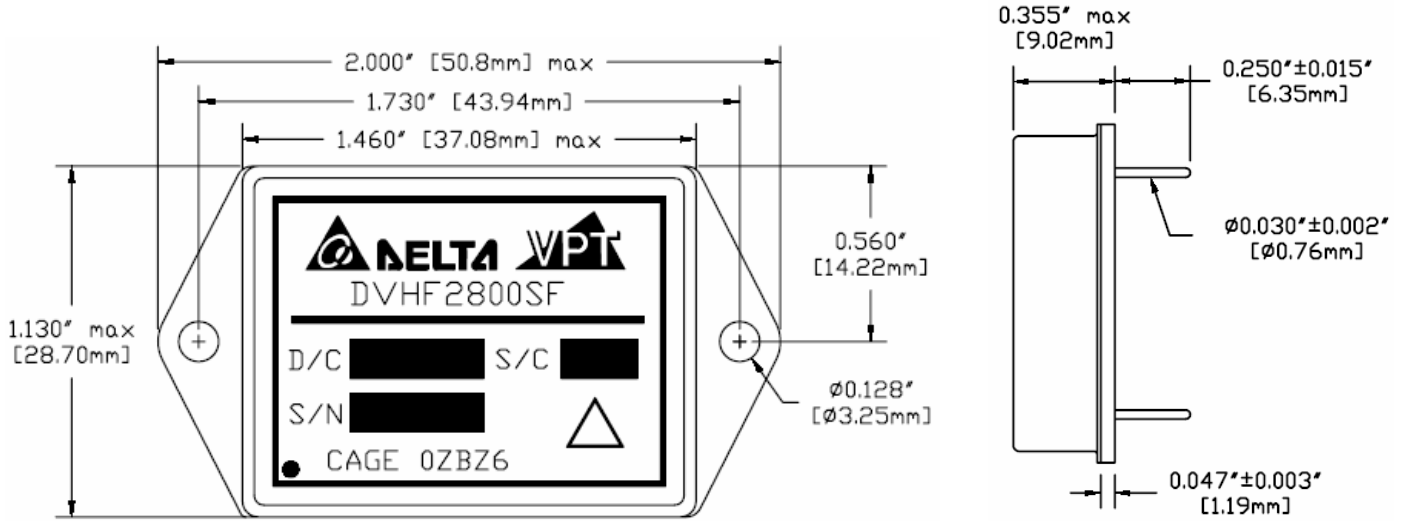


**BOTTOM VIEW**

PIN	FUNCTION
1	INHIBIT
2	N/C
3	OUT COM
4	+V OUT
5	N/C
6	CASE
7	IN COM
8	28V IN

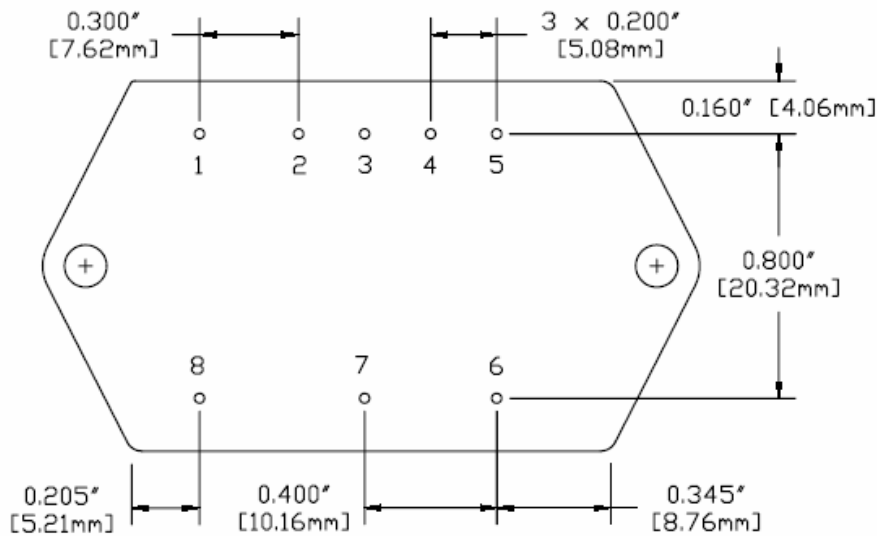
**Figure 13 – Non-Flanged Package and Pinout**  
(Dimensional Limits are  $\pm 0.005$ " Unless Otherwise Stated)

## PACKAGE SPECIFICATIONS (FLANGED)



**TOP VIEW**

**SIDE VIEW**



**BOTTOM VIEW**

PIN	FUNCTION
1	INHIBIT
2	N/C
3	OUT COM
4	+V OUT
5	N/C
6	CASE
7	IN COM
8	28V IN

**Figure 14 – Flanged Package and Pinout**  
(Dimensional Limits are ±0.005" Unless Otherwise Stated)

## PACKAGE PIN DESCRIPTION

Pin	Function	Description
1	INHIBIT	Logic Low = Disabled Output. Connecting the inhibit pin to input common causes converter shutdown. Logic High = Enabled Output. Unconnected or open collector TTL.
2	N/C	No Connection
3	OUT COM	Output Common Connection
4	+V OUT	Positive Output Voltage Connection
5	N/C	No Connection
6	CASE	Case Connection
7	IN COM	Input Common Connection
8	28V IN	Positive Input Voltage Connection

## ENVIRONMENTAL SCREENING (100% Tested Per MIL-STD-883 as referenced to MIL-PRF-38534)

Screening	MIL-STD-883	Standard (No Suffix)	Extended /ES	HB /HB	Class H /H	Class K /K
Non-Destructive Bond Pull	Method 2023	•	•	•	•	•
Internal Visual	Method 2017, 2032 Internal Procedure	•	•	•	•	•
Temperature Cycling	Method 1010, Condition C Method 1010, -55°C to 125°C		•	•	•	•
Constant Acceleration	Method 2001, 3000g, Y1 Direction Method 2001, 500g, Y1 Direction		•	•	•	•
PIND	Method 2020, Condition A <sup>2</sup>					•
Pre Burn-In Electrical	100% at 25°C					•
Burn-In	Method 1015, 320 hours at +125°C Method 1015, 160 hours at +125°C 96 hours at +125°C 24 hours at +125°C	•	•	•	•	•
Final Electrical	MIL-PRF-38534, Group A <sup>1</sup> 100% at 25°C	•	•	•	•	•
Hermeticity	Method 1014, Fine Leak, Condition A Method 1014, Gross Leak, Condition C Dip (1 x 10 <sup>-3</sup> )	•	•	•	•	•
Radiography	Method 2012 <sup>3</sup>					•
External Visual	Method 2009	•	•	•	•	•

- Notes:
1. 100% R&R testing at -55°C, +25°C, and +125°C with all test data included in product shipment.
  2. PIND test Certificate of Compliance included in product shipment.
  3. Radiographic test Certificate of Compliance and film(s) included in product shipment.

## ORDERING INFORMATION

<b>DVHF</b>	<b>28</b>	<b>05</b>	<b>S</b>	<b>F</b>	<b>R</b>	<b>/HB</b>	-	<b>XXX</b>
1	2	3	4	5	6	7		8

(1)

(2)

(3)

(4)

Product Series	Nominal Input Voltage		Output Voltage		Number of Outputs	
<b>DVHF</b>	<b>28</b>	28 Volts	<b>1R9</b> <b>3R3</b> <b>05</b> <b>5R2</b> <b>12</b> <b>15</b>	1.9 Volts 3.3 Volts 5 Volts 5.2 Volts 12 Volts 15 Volts	<b>S</b>	Single

(5)

(6)

(7)

(8)

Package Option		Rad-Hard Option <sup>2</sup>		Screening Code <sup>1,3</sup>		Additional Screening Code
<b>None</b> <b>F</b>	Non-Flanged Flanged	<b>None</b> <b>R</b>	Standard 100 kRad	<b>None</b> <b>/ES</b> <b>/HB</b> <b>/H</b> <b>/K</b>	Standard Extended HB Class H Class K	Contact Sales

- Notes:
1. Contact the VPT Inc. Sales Department for availability of Class H (/H) or Class K (/K) qualified products.
  2. VPT Inc. is not currently qualified to a DSCC certified radiation hardness assurance program.
  3. VPT Inc. reserves the right to ship higher screened or SMD products to meet lower screened orders at our sole discretion unless specifically forbidden by customer contract.

Please contact your sales representative or the VPT Inc. Sales Department for more information concerning additional environmental screening and testing, different input voltage, output voltage, power requirement, source inspection, and/or special element evaluation for space or other higher quality applications.

## SMD (STANDARD MICROCIRCUIT DRAWING) NUMBERS

<b>Standard Microcircuit Drawing (SMD)</b>	<b>DVHF2800S Series Similar Part Number</b>
5962-0324306HXC 5962-0324306HYC	DVHF281R9S/H DVHF281R9SF/H
5962-0324301HXC 5962-0324301HYC	DVHF283R3S/H DVHF283R3SF/H
5962-0324302HXC 5962-0324302HYC	DVHF2805S/H DVHF2805SF/H
5962-0324303HXC 5962-0324303HYC	DVHF285R2S/H DVHF285R2SF/H
5962-0324304HXC 5962-0324304HYC	DVHF2812S/H DVHF2812SF/H
5962-0324305HXC 5962-0324305HYC	DVHF2815S/H DVHF2815SF/H

Do not use the DVHF2800S Series similar part number for SMD product acquisition. It is listed for reference only. For exact specifications for the SMD product, refer to the SMD drawing. SMD's can be downloaded from the DSCC website at <http://www.dscclia.mil/programs/smcr/>. The SMD number listed above is for MIL-PRF-38534 Class H screening, standard gold plated lead finish, and no RHA (Radiation Hardness Assurance) level. Please reference the SMD for other screening levels, lead finishes, and radiation levels.

## CONTACT INFORMATION

To request a quotation or place orders please contact your sales representative or the VPT Inc. Sales Department at:

**Phone:** (425) 353-3010  
**Fax:** (425) 353-4030  
**E-mail:** [vptsales@vpt-inc.com](mailto:vptsales@vpt-inc.com)

All information contained in this datasheet is believed to be accurate, however, no responsibility is assumed for possible errors or omissions. The products or specifications contained herein are subject to change without notice.