

# Precision voltage regulator

# $\mu$ A723/723C

## DESCRIPTION

The  $\mu$ A723/ $\mu$ A723C is a monolithic precision voltage regulator capable of operation in positive or negative supplies as a series, shunt, switching, or floating regulator. The 723 contains a temperature-compensated reference amplifier, error amplifier, series pass transistor, and current limiter, with access to remote shutdown.

## FEATURES

- Positive or negative supply operation
- Series, shunt, switching, or floating operation
- 0.01% line and load regulation
- Output voltage adjustable from 2V to 37V
- Output current to 150mA without external pass transistor
- $\mu$ A723 MIL-STD-883A, B, C available

## PIN CONFIGURATION

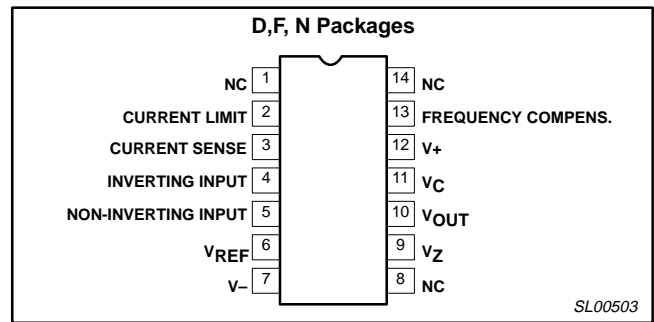

Figure 1. Pin Configuration

## ORDERING INFORMATION

DESCRIPTION	TEMPERATURE RANGE	ORDER CODE	DWG #
14-Pin Ceramic Dual In-Line Package (CERDIP)	-55°C to 125°C	$\mu$ A723F	0581B
14-Pin Plastic Dual In-Line Package (DIP)	0 to 70°C	$\mu$ A723CN	SOT27-1
14-Pin Plastic Small Outline (SO) Package	0 to 70°C	$\mu$ A723CD	SOT108-1

## EQUIVALENT CIRCUIT

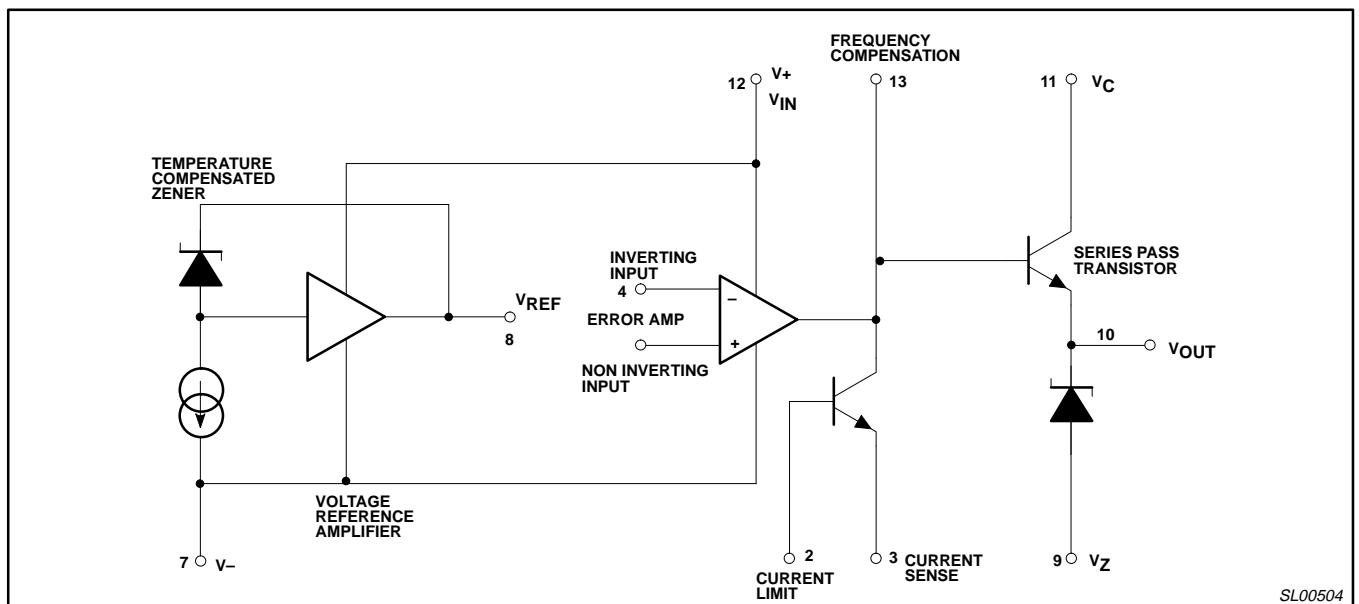

Figure 2. Equivalent Circuit

# Precision voltage regulator

$\mu$ A723/723C

## ABSOLUTE MAXIMUM RATINGS

SYMBOL	PARAMETER	RATING	UNIT
	Pulse voltage from V+ to V- (50ms)	50	V
	Continuous voltage from V+ to V-	40	V
	Input-output voltage differential	40	V
V <sub>DIFF</sub>	Error amplifier maximum input differential voltage	±5	V
V <sub>CM</sub>	Error amplifier non-inverting input (Pin 5) to -V (Pin 7)	8	V
I <sub>OUT</sub>	Maximum output current	150	mA
	Current from V <sub>REF</sub>	15	mA
	Current from V <sub>Z</sub>	25	mA
P <sub>MAX</sub>	Maximum power dissipation T <sub>A</sub> =25°C (still-air) <sup>1</sup>		
	F package	1190	mW
	N package	1420	mW
	D package	1040	mW
T <sub>A</sub>	Operating ambient temperature range		
	$\mu$ A723	-55 to +125	°C
	$\mu$ A723C	0 to 70	°C
T <sub>STG</sub>	Storage temperature range	-65 to +150	°C
T <sub>SOLD</sub>	Lead soldering temperature (10sec max)	300	°C

### NOTES:

- The following derating factors should be applied above 25°C
  - F package at 9.5mW/°C
  - N package at 11.4mW/°C
  - D package at 8.3mW/°C

# Precision voltage regulator

# μA723/723C

## DC ELECTRICAL CHARACTERISTICS

T<sub>A</sub>=25°C, unless otherwise specified.<sup>1</sup>

SYMBOL	PARAMETER	TEST CONDITIONS	μA723			μA723C			UNITS
			Min	Typ	Max	Min	Typ	Max	
V <sub>R LINE</sub>	Line regulation <sup>2</sup>	V <sub>IN</sub> =12V to V <sub>IN</sub> =15V V <sub>IN</sub> =12V to V <sub>IN</sub> =40V		0.01 0.02	0.1 0.2		0.01 0.1	0.1 0.5	%V <sub>OUT</sub>
V <sub>R LOAD</sub>	Load regulation <sup>2</sup>	I <sub>L</sub> =1mA to I <sub>L</sub> =50mA		0.03	0.15		0.03	0.2	%V <sub>OUT</sub>
ΔV <sub>IN</sub> /ΔV <sub>O</sub>	Ripple Rejection	f=50Hz to 10kHz, C <sub>REF</sub> =0		74			74		dB
		f=50Hz to 10kHz, C <sub>REF</sub> =5μF		86			86		
I <sub>OS</sub>	Short-circuit current	R <sub>SC</sub> =10Ω, V <sub>OUT</sub> =0		65			65		mA
V <sub>REF</sub>	Reference voltage	I <sub>REF</sub> =0.1mA	6.95	7.15	7.35	6.80	7.15	7.50	V
V <sub>REF (LOAD)</sub>	Reference voltage change with load	I <sub>REF</sub> =0.1mA to 5mA			20			20	mV
V <sub>NOISE</sub>	Output noise voltage	BW=100Hz to 10kHz, C <sub>REF</sub> =0		20			20		μV <sub>RMS</sub>
		BW=100Hz to 10kHz, C <sub>REF</sub> =5μF		2.5			2.5		
S	Long-term stability	T <sub>j</sub> =T <sub>jmax.</sub> TA=25°C for end point measurement		0.1			0.1		%1000 hrs.
I <sub>SCD</sub>	Standby current drain	I <sub>L</sub> =0, V <sub>IN</sub> =30V		2.3	3.5		2.3	4.0	mA
V <sub>IN</sub>	Input voltage range		9.5		40	9.5		40	V
V <sub>OUT</sub>	Output voltage range		2.0		37	2.0		37	V
V <sub>DIFF</sub>	Input-output voltage differential		3.0		38	3.0		38	V
<b>The following specifications apply over the operating temperature ranges.</b>									
V <sub>R LINE</sub>	Line regulation	V <sub>IN</sub> =12V to V <sub>IN</sub> =15V			0.3			0.3	%V <sub>OUT</sub>
V <sub>R LOAD</sub>	Load regulation	I <sub>L</sub> =1mA to I <sub>L</sub> =50mA			0.6			0.6	%V <sub>OUT</sub>
TC	Average temperature coefficient of output voltage			0.002	0.015		0.003	0.015	%/°C

### NOTES:

- V<sub>IN</sub>=V<sub>+</sub>=V<sub>C</sub>=12V, V<sub>-</sub>=0V, V<sub>OUT</sub>=5V, I<sub>L</sub>=1mA, R<sub>SC</sub>=0, C<sub>1</sub>=100pF, C<sub>REF</sub>=0 and divider impedance as seen by error amplifier ≤10kΩ.
- The load and line regulation specifications are for constant junction temperature. Temperature drift effects must be taken into account separately when the unit is operating under conditions of high dissipation.

# Precision voltage regulator

## $\mu$ A723/723C

### TYPICAL PERFORMANCE CHARACTERISTICS

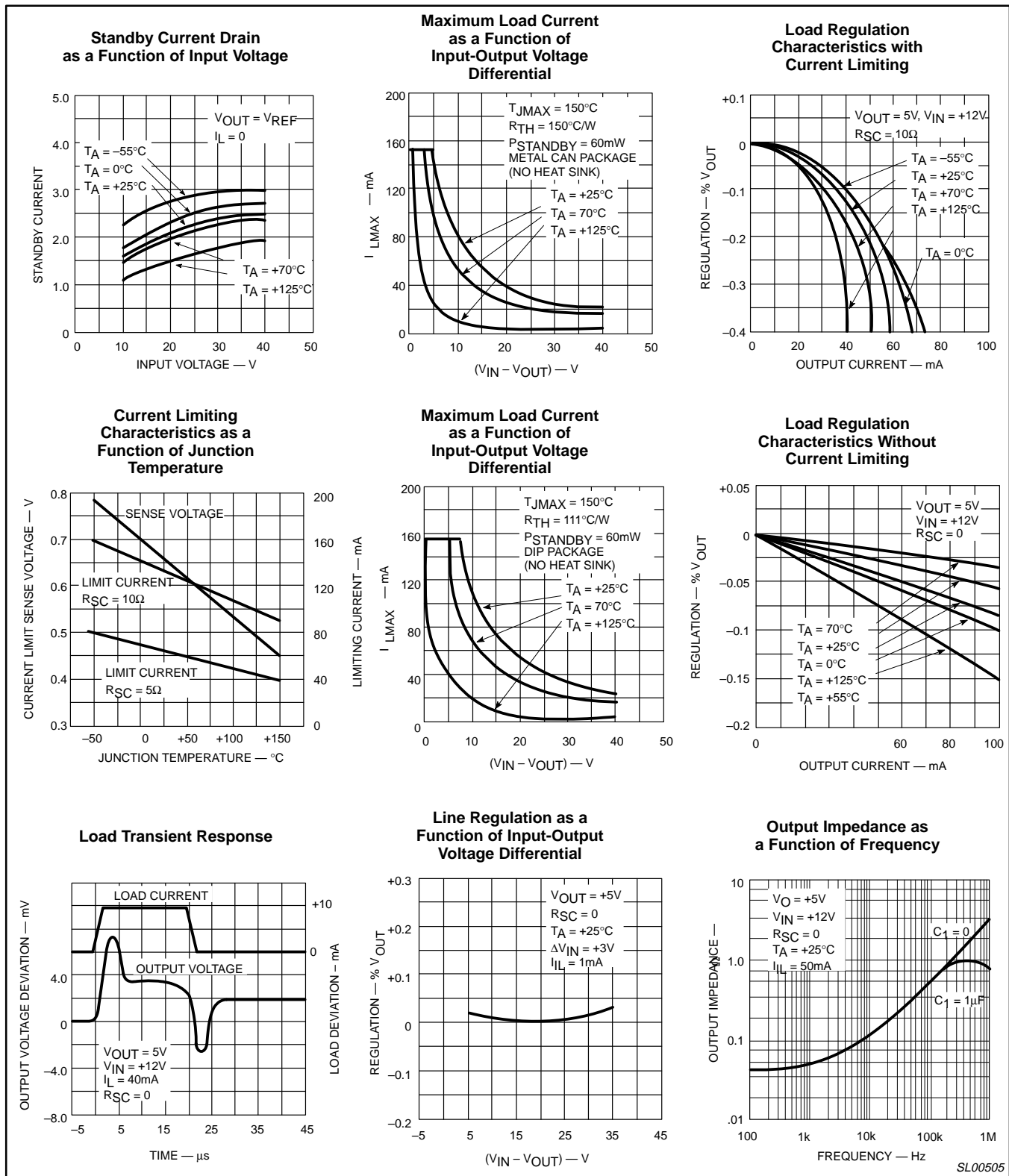

Figure 3. Typical Performance Characteristics

# Precision voltage regulator

# μA723/723C

## TYPICAL PERFORMANCE CHARACTERISTICS (Continued)

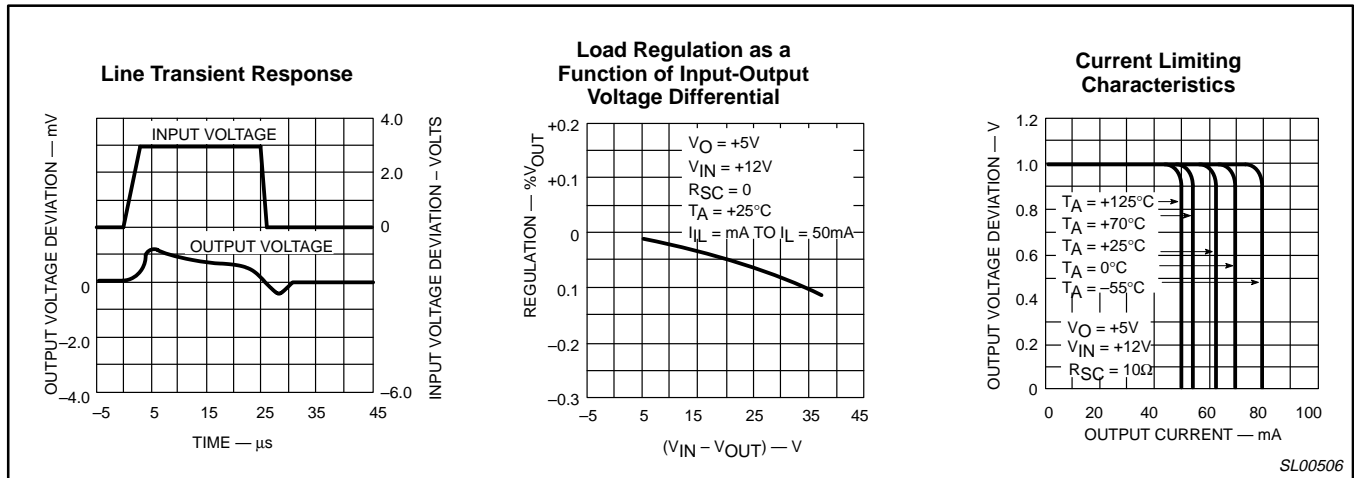

Figure 4. Typical Performance Characteristics (cont.)

## TYPICAL APPLICATIONS

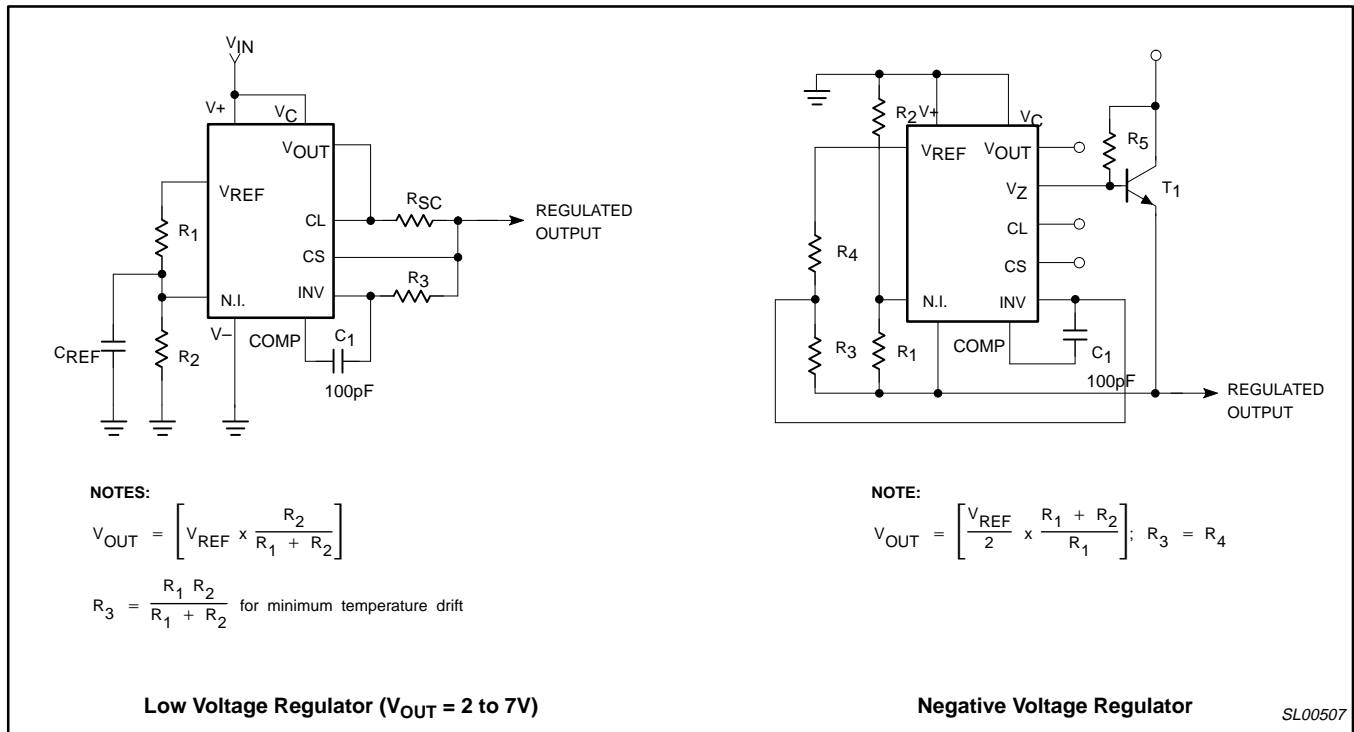
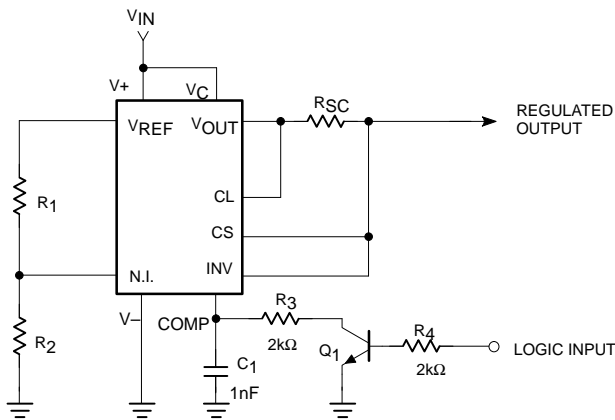

Figure 5. Typical Applications

# Precision voltage regulator

# μA723/723C

## TYPICAL APPLICATIONS (Continued)



NOTE:

$$V_{OUT} = \left[ V_{REF} \times \frac{R_2}{R_1 + R_2} \right]$$

### Remote Shutdown Regulator With Current Limiting ( $V_{OUT} = 2$ to $7V$ )

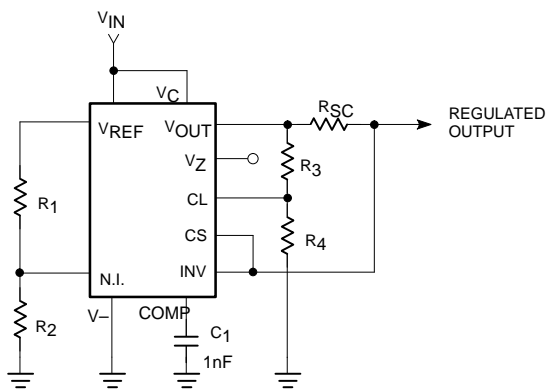

NOTES:

$$I_{KNEE} = \left[ \frac{V_{OUT}}{R_{SC}} \frac{R_3}{R_4} + \frac{V_{SENSE}}{R_{SC}} \frac{(R_3 + R_4)}{R_4} \right]$$

$$V_{OUT} = \left[ V_{REF} \times \frac{R_1 + R_2}{R_4} \right]$$

$$I_{SHORT\ CKT} = \left[ \frac{V_{SENSE}}{R_{SC}} \times \frac{R_3 + R_4}{R_4} \right]$$

### Foldback Current Limiting Regulator ( $V_{OUT} = 2$ to $7V$ )

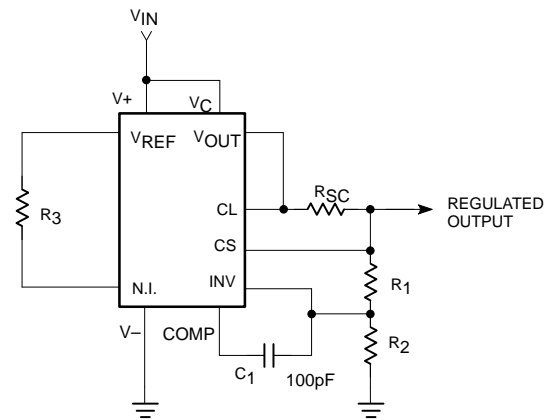

NOTE:

$$V_{OUT} = \left[ V_{REF} \times \frac{R_2}{R_1 + R_2} \right]; R_3 = R_4$$

$$R_3 = \frac{R_1 R_2}{R_1 + R_2} \text{ for minimum temperature drift}$$

R3 may be eliminated for minimum component count

### High Voltage Regulator ( $V_{OUT} = 7$ to $37V$ )

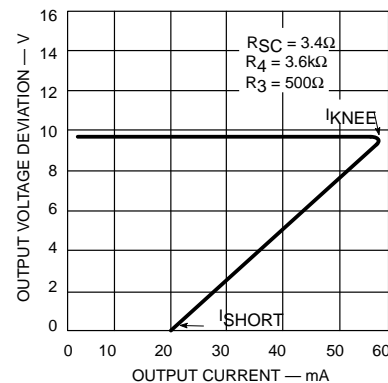

NOTES:

$$\frac{R_4}{R_3} = \frac{V_{OUT} I_{SC}}{V_{SENSE} (I_{KNEE} - I_{SHORT\ CKT})} - 1$$

$$R_{SC} = \frac{V_{SENSE}}{I_{SC}} \left[ 1 + \frac{R_3}{R_4} \right]$$

SL00508

Figure 6. Typical Applications (cont.)