

**PLEASE CHECK WWW.MOLEX.COM FOR LATEST PART INFORMATION**

**Part Number:** [0190670109](#)  
**Status:** **Active**  
**Description:** NylaKrimp™ Funnel Entry Ring Tongue Terminal for 2/0 AWG Wire, Stud #12

**Documents:**

[Drawing \(PDF\)](#) [RoHS Certificate of Compliance \(PDF\)](#)

**Agency Certification**

UL E32244

**General**

Product Family Ring and Spade Terminals  
 Series [19067](#)  
 Crimp Quality Equipment Yes  
 Mil-Spec N/A  
 Product Name NylaKrimp™  
 Type Ring

**Physical**

Barrel Type Closed - Brazed  
 Flammability 94V-0  
 Insulation Nylon (PA)  
 Material - Plating Mating Tin  
 Packaging Type Bag  
 Stud Size 1/2" (M12)  
 Termination Interface: Style Crimp or Compression  
 Wire Insulation Diameter 19.43mm (.765") max.  
 Wire Size AWG 2/0

**Material Info**

Old Part Number J-985-12

**Reference - Drawing Numbers**

Sales Drawing SD-19067-001

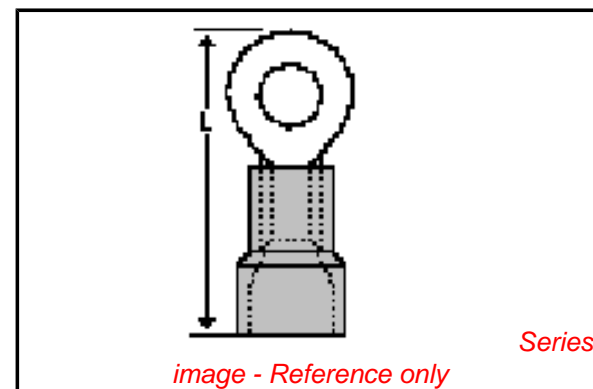

image - Reference only

**EU RoHS**

**ELV and RoHS Compliant**

**REACH SVHC**

Not Reviewed

**Halogen-Free**

Status

**Not Reviewed**

**China RoHS**



**Need more information on product environmental compliance?**

Email [productcompliance@molex.com](mailto:productcompliance@molex.com)  
 For a multiple part number RoHS Certificate of Compliance, [click here](#)

Please visit the [Contact Us](#) section for any non-product compliance questions.

**Search Parts in this Series**

[19067Series](#)

**Application Tooling | [FAQ](#)**

*Tooling specifications and manuals are found by selecting the products below. Crimp Height Specifications are then contained in the Application Tooling Specification document.*

**Global**

Description	Product #
Manual Putt Pump Hydraulic System, Die set required	<a href="#">0192860117</a>
Die Set (large) for the HHLS Hydraulic Crimper	<a href="#">0192890025</a>
Putt Pump Dieless Head System	<a href="#">0192860065</a>

MATERIAL NUMBER	ALTERNATE NUMBER	STUD SIZES	"S"
190670109	J-985-12	1/2	.515
190670110	J-985-14	1/4	.265
190670111	J-985-38	3/8	.390
190670112	J-985-56	5/16	.328
190670113	J-985-76	7/16	.453

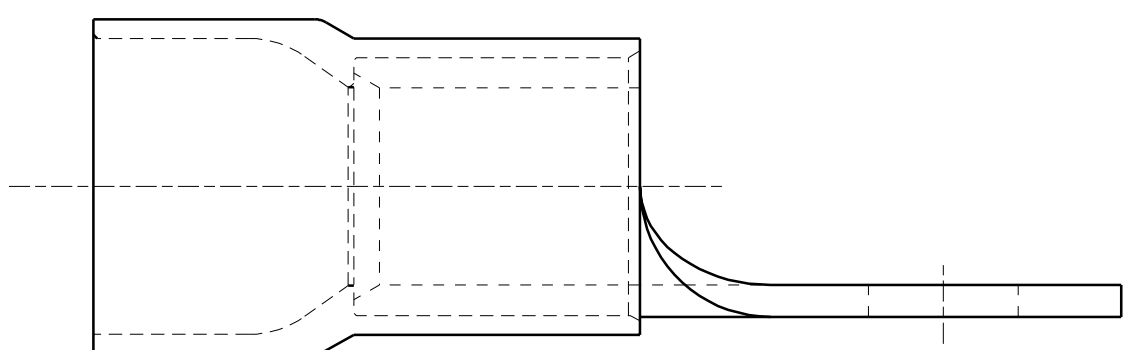
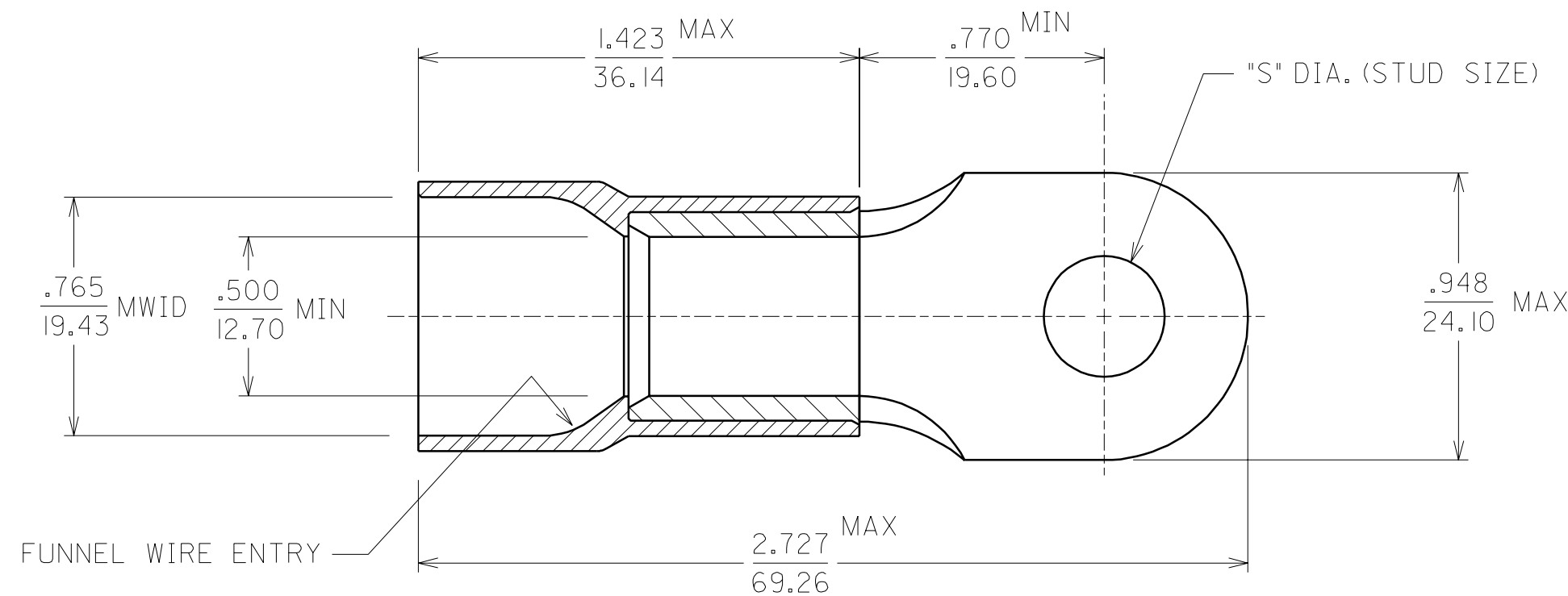

- NOTES:
1. MATERIAL: COPPER .083 THICK  
PLATING: ELECTROPLATE TIN
  2. INSULATION: YELLOW NYLON 6/6
  3. MWID=MAXIMUM WIRE INSULATION DIA.
  4. ALL DIMENSIONS IN INCHES/(MM).

A	NEW CUST DGN ETC2001-0251 01/02/27 EDB
LTR.	REVISIONS

CUSTOMER DRAWING

DIMENSIONS SHOWN (METRIC) INCH		REVISE ONLY ON CAD SYSTEM																			
UNLESS OTHERWISE SPECIFIED TOLERANCES: ANGULAR ± 1/2°		TITLE NYLAKRIMP FUNNEL ENTRY RING TONGUE TERMINAL 2/0 AWG																			
<table border="1"> <thead> <tr> <th></th> <th>INCH</th> <th>METRIC</th> </tr> </thead> <tbody> <tr> <td>3 PLACE</td> <td>± .005</td> <td>± ---</td> </tr> <tr> <td>2 PLACE</td> <td>± .01</td> <td>± 0.13</td> </tr> <tr> <td>1 PLACE</td> <td>± ---</td> <td>± 0.25</td> </tr> </tbody> </table>			INCH	METRIC	3 PLACE	± .005	± ---	2 PLACE	± .01	± 0.13	1 PLACE	± ---	± 0.25	<table border="1"> <tr> <td>molex ETC INC.</td> <td>SHEET NO.</td> <td>DATE</td> </tr> <tr> <td>PINELLAS PARK, FLA. 33781 U.S.A.</td> <td>1 OF 1</td> <td>01/02/02</td> </tr> </table>		molex ETC INC.	SHEET NO.	DATE	PINELLAS PARK, FLA. 33781 U.S.A.	1 OF 1	01/02/02
	INCH	METRIC																			
3 PLACE	± .005	± ---																			
2 PLACE	± .01	± 0.13																			
1 PLACE	± ---	± 0.25																			
molex ETC INC.	SHEET NO.	DATE																			
PINELLAS PARK, FLA. 33781 U.S.A.	1 OF 1	01/02/02																			
DRAFT WHERE APPLICABLE MUST REMAIN WITHIN DIMENSIONS		PART NO. SEE CHART																			
<table border="1"> <tr> <td>DRWG. BY</td> <td>EDB</td> <td>CHK'D. BY</td> <td>HEB</td> </tr> <tr> <td>APP'D. BY</td> <td>RWD</td> <td>SCALE</td> <td>NO:NE</td> </tr> </table>		DRWG. BY	EDB	CHK'D. BY	HEB	APP'D. BY	RWD	SCALE	NO:NE	<table border="1"> <tr> <td>DRWG. NO.</td> <td>SD-19067-001</td> </tr> </table>		DRWG. NO.	SD-19067-001								
DRWG. BY	EDB	CHK'D. BY	HEB																		
APP'D. BY	RWD	SCALE	NO:NE																		
DRWG. NO.	SD-19067-001																				
THIS DRAWING CONTAINS INFORMATION THAT IS PROPRIETARY TO MOLEX-ETC INC. AND SHOULD NOT BE USED WITHOUT WRITTEN PERMISSION.		DIV.	SIZE																		
		ET	B																		