

FEATURES

- dual channel signal processing
- 2nd (4th) order state variable filter
- adjustable crossover frequency
- adjustable compression ratio from 1:1 to 4:1
- independent compression ratio adjustment for low and high frequency band
- adjustable AGC threshold levels
- unique twin average detectors
- handles high input levels
- low THD and IMD distortion
- drives class D integrated receivers
- MPO range externally adjustable

PACKAGING

- Chip
- Au Bump

DEVICE DESCRIPTION

The DynamEQ® II product family is a second generation Wide Dynamic Range Compression (WDRC) system.

GB570 (GC570) incorporates 12 dB/oct (24 dB/oct) filtering and is designed to accommodate CIC and ITC size requirements.

The gain and frequency response is dependant on the user's environment.

Twin averaging detector circuits are optimized for sound quality during normal listening without sacrificing comfort during sudden loud inputs.

All input signals to DynamEQ® II, are processed by 2:1 compression before subsequent band splitting.

The 12 dB/oct (24 dB/oct) band split filter ahead of the expander/compressor circuits allows for independent compression ratio adjustment (1:1 to 4:1) in high and low frequency channels.

The gain setting stage is followed by a class D integrated receiver preamplifier stage. Symmetrical peak clipping is used to achieve MPO adjustment.

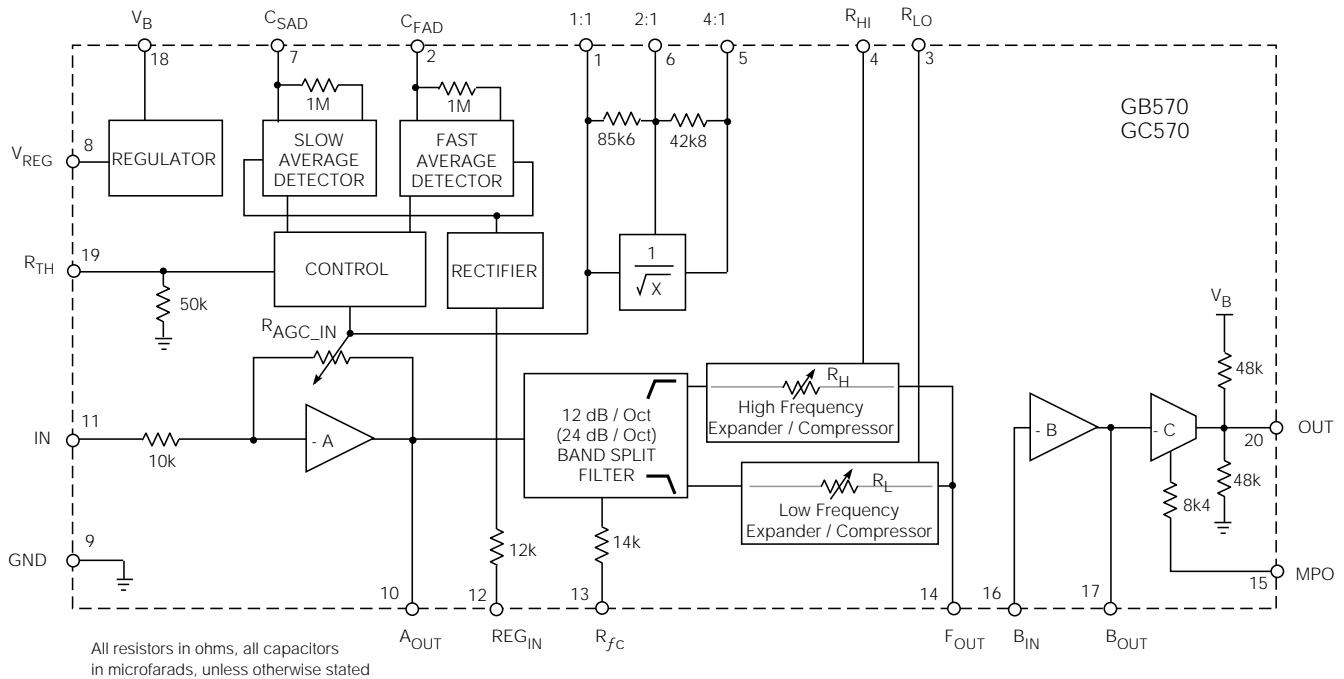

FUNCTIONAL BLOCK DIAGRAM

ABSOLUTE MAXIMUM RATINGS

PARAMETER	VALUE / UNITS
Supply Voltage	3 VDC
Power Dissipation	25 mW
Operating Temperature Range	-10° C to 40° C
Storage Temperature Range	-20° C to 70° C

CAUTION
CLASS 1 ESD SENSITIVITY



PAD CONNECTION

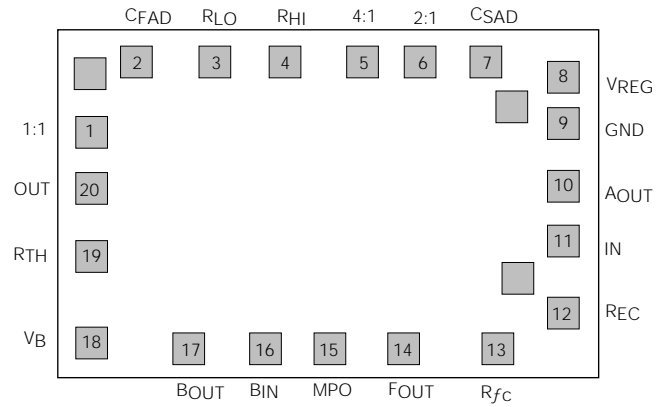

ELECTRICAL CHARACTERISTICS

Conditions: Supply Voltage $V_b = 1.3$ V, Frequency = 1 kHz, Temperature = 25°C

PARAMETER	SYMBOL	CONDITIONS	MIN	TYP	MAX	UNITS
IC Current	I_{AMP}		-	370	530	μ A
Minimum Voltage	V_b		1.1	-	-	V
Total Harmonic Distortion	THD	$V_{IN} = -40$ dBV at 1kHz	-	0.2	1.0	%
THD with Maximum Allowable Input	THD_M	$V_{IN} = -23$ dBV, $R_{vc} = 47$ k Ω	-	2	10	%
Input Referred Noise	IRN	Aweight	-	3.0	-	μ V _{RMS}
Total System Gain	A_V	$V_{IN} = -90$ dBV	46	49	52	dB
Regulator Voltage	V_{REG}	$I_{LOAD} = 30$ μ A	890	930	1000	mV
AGC						
Lower Threshold	TH_{LO}		-91	-87	-83	dBV
Upper Threshold	TH_{HI}		-36	-32	-28	dBV
Compression Gain Range	ΔA	Gain(-90dBV _{IN}) - Gain(-30dBV _{IN})	37.5	40.5	43.5	dB
System Gain in Compression	A_{60}	$V_{IN} = -60$ dBV	26	29	32	dB
Min. Compression Ratio	$CMP_{1:1}$	$V_{IN} = 3$ kHz, -60dBV to -40dBV, Rhp=1:1 Rlp=1:1	0.9	1.0	1.1	Ratio
Max. Comp. Ratio	$CMP_{4:1}$	$V_{IN} = 3$ kHz, -60dBV to -40dBV, Rhp=4:1, Rlp=4:1	3.6	4.0	4.3	Ratio
Fast Detector Time Constant	τ_{FAST}		-	10	-	ms
Slow Detector Time Constant	τ_{SLOW}		-	220	-	ms
FILTER						
Maximum Cross-over Frequency	f_{c_0}	$R_{fc} = 0$ Ω	3.0	3.9	-	kHz
Nominal Cross-over Frequency	$f_{c_{22}}$	$R_{fc} = 22$ k Ω	1.5	1.9	2.3	kHz
Minimum Cross-over Frequency	$f_{c_{220}}$	$R_{fc} = 220$ k Ω	-	0.9	1.4	kHz
Filter Rolloff Rate (GB570)			-	12	-	dB/oct
(GC570)			-	24	-	dB/oct
STAGE A and B						
Open Loop Gain (B)	A_{OL_B}		-	52	-	dB
Input Impedance (A)	R_{IN}		8	11	12	k Ω
OUTPUT STAGE						
Stage Gain	A_C	$V_{IN} = -30$ dBV	7	9	11	dB
Max Output Level	MPO	$R_{vc} = 220$ k Ω , $V_{IN} = -25$ dBV	-14.5	-12.5	-10.5	dBV
MPO Range	ΔMPO	$R_{MPO} = 0$ Ω to 50k Ω	13	15	17	dB
Output Resistance	R_{OUT}		-	24	-	k Ω

All conditions and parameters remain as shown in Test Circuit unless otherwise stated in "Conditions" column.

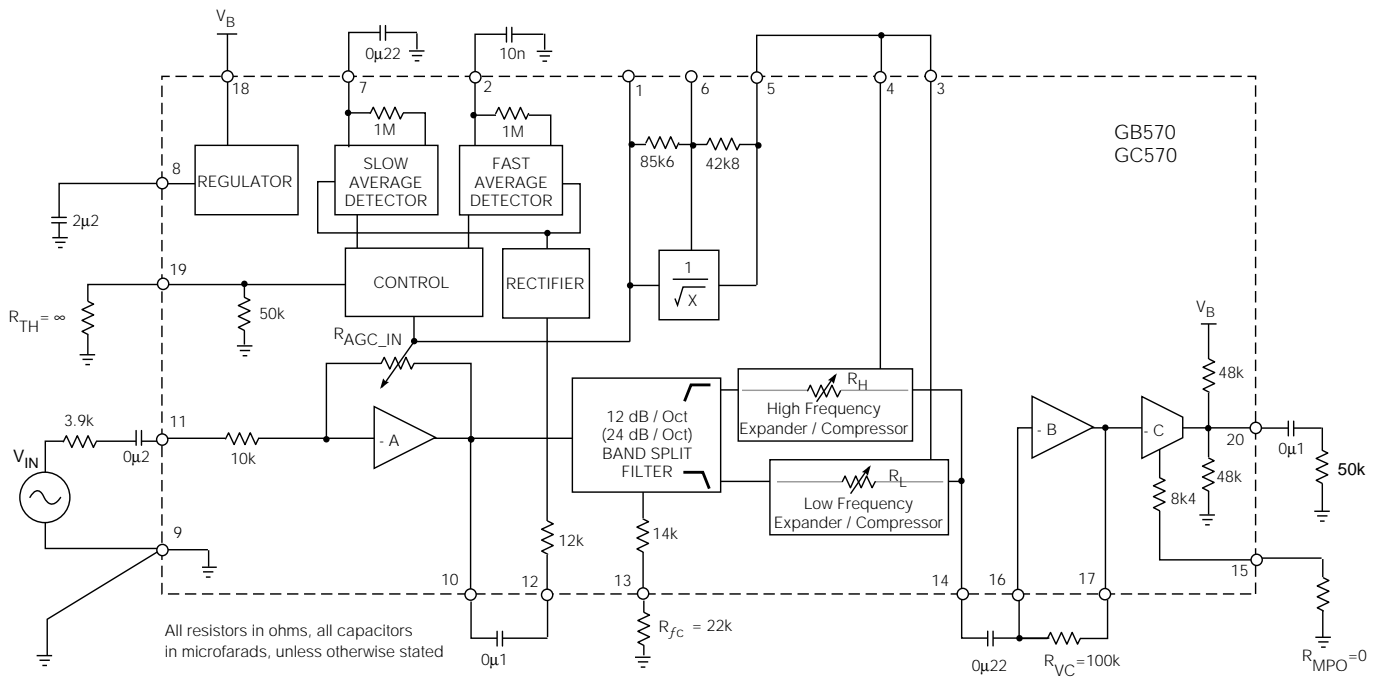

Fig. 1 Production Test Circuit

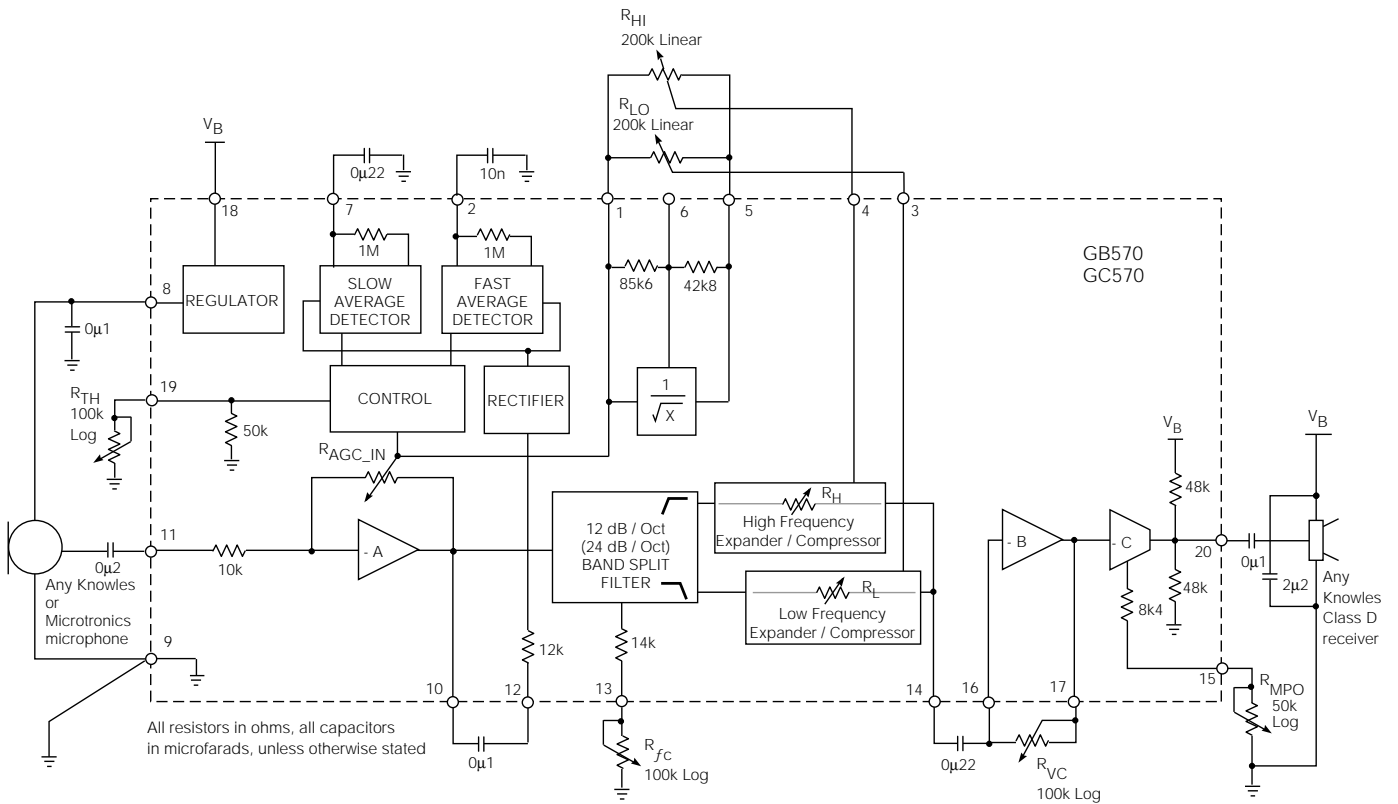

Fig. 2 Maximum Flexibility Hearing Instrument Application

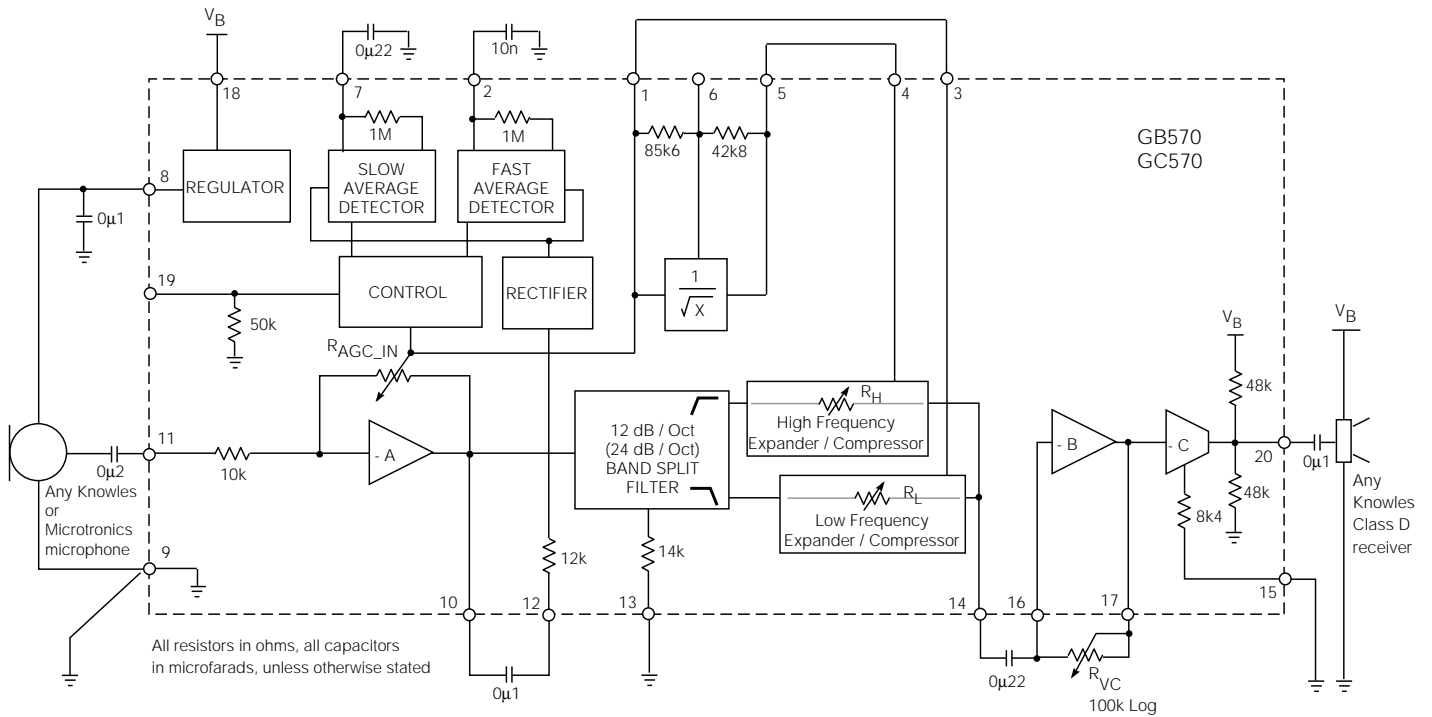

Fig. 3 Minimum Component Hearing Instrument Application

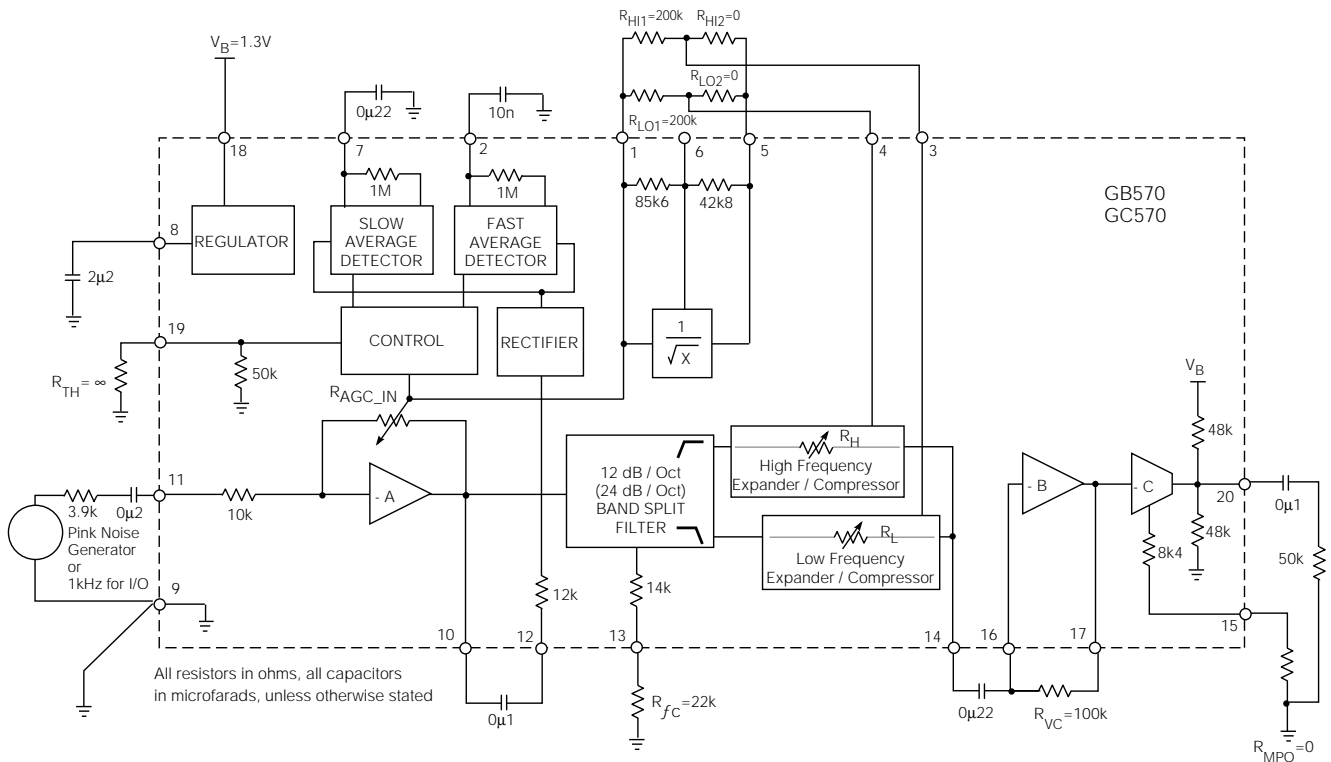

Fig. 4 Characterization Circuit (Used to generate typical curves)

TYPICAL PERFORMANCE CURVES

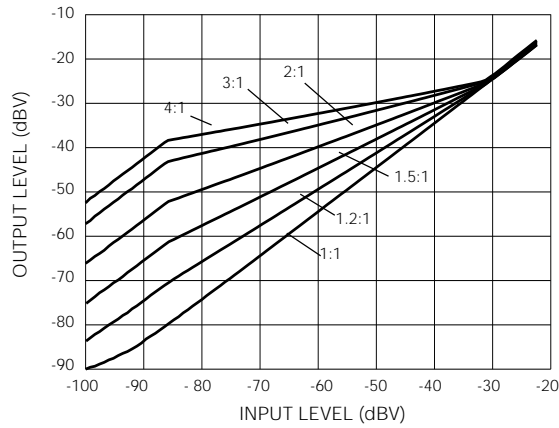

Fig. 5 I/O Transfer function for Different Compression Ratios

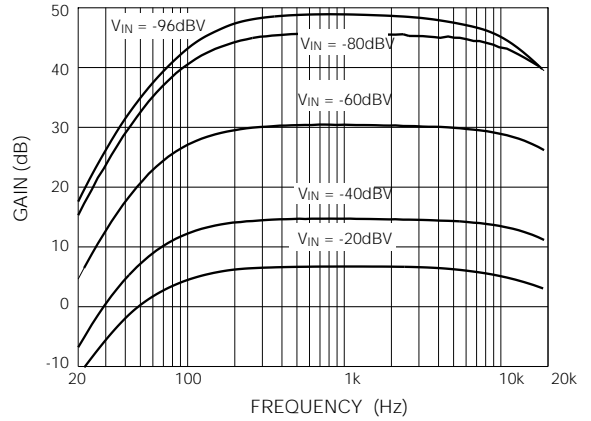

Fig. 6 Frequency Response for Different Input Levels

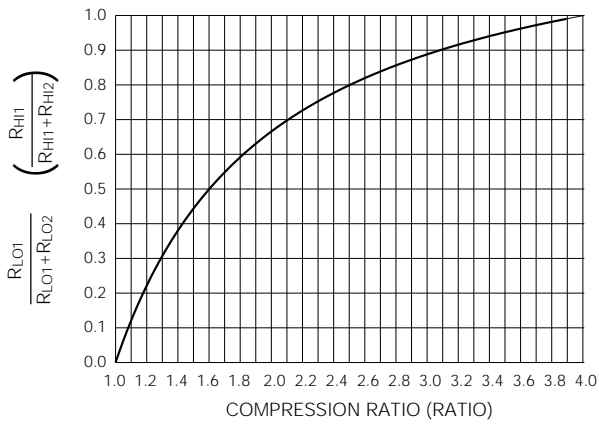

Fig. 7 Compression Settings Resistor Ratio for High Pass Channel (R_{H11} & R_{H12}) and Low Pass Channel (R_{L01} & R_{L02})

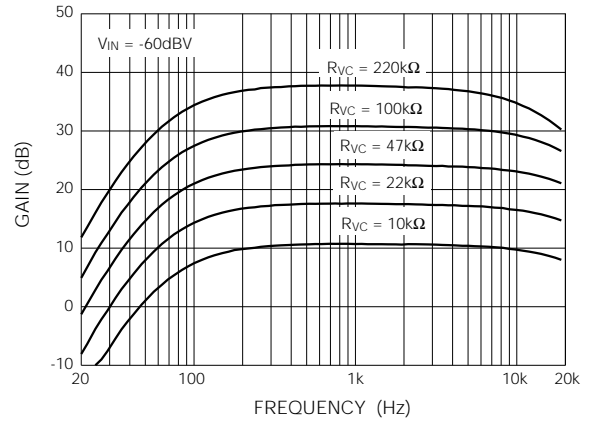

Fig. 8 Frequency Response for Different R_{VC} Values

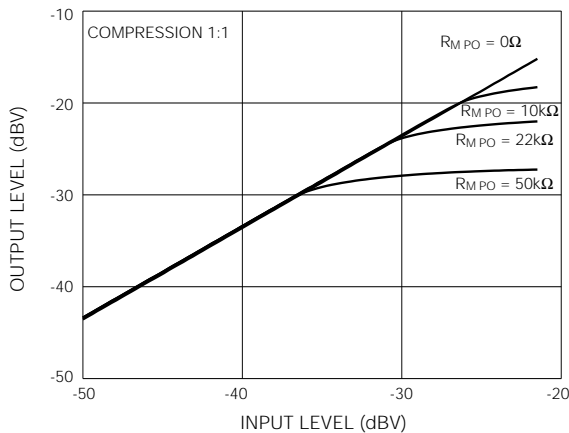

Fig. 9 I/O Transfer Function for Different R_{MPO} Resistors

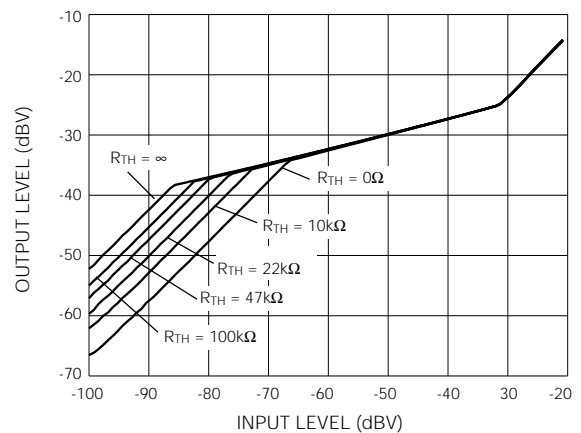

Fig. 10 I/O Transfer Function for Different R_{TH} Resistors

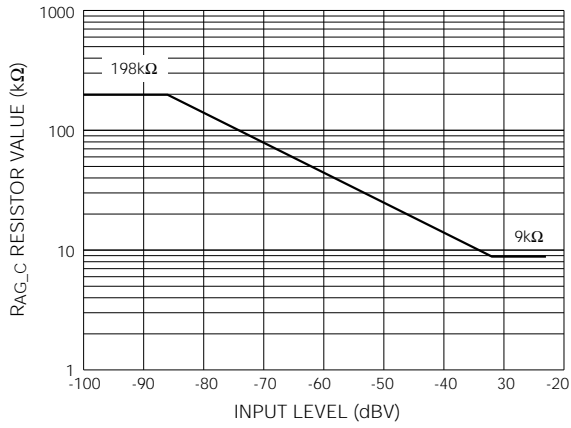

Fig. 11 Stage A Compressor Feedback Resistor Value

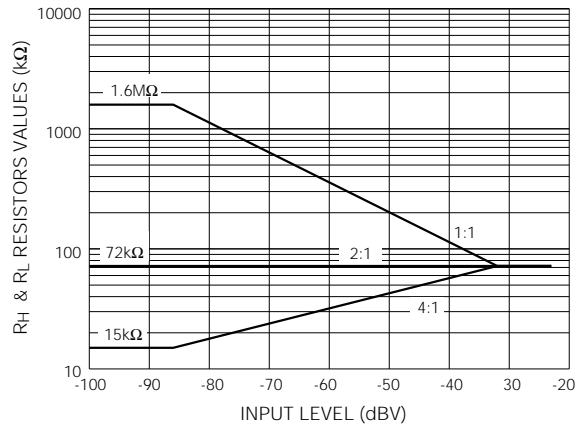

Fig. 12 Expander / Compressor Resistors Values

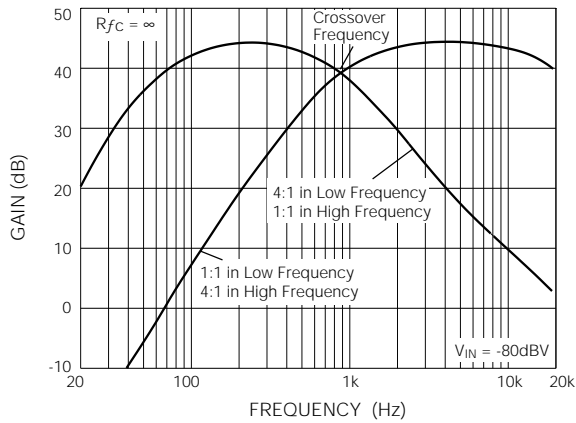

Fig. 13 Crossover Frequency Representation for GB570 Processor

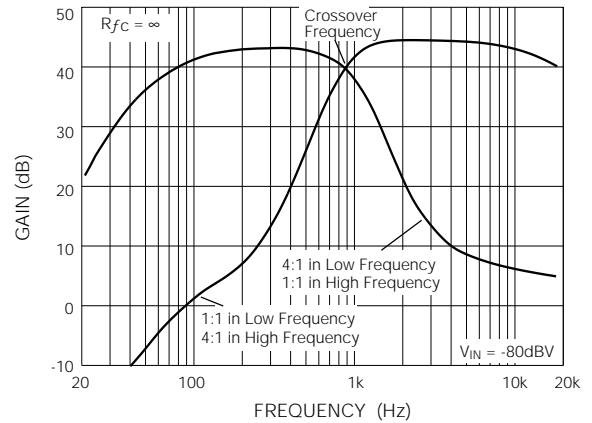

Fig. 14 Crossover Frequency Representation for GGC570 Processor

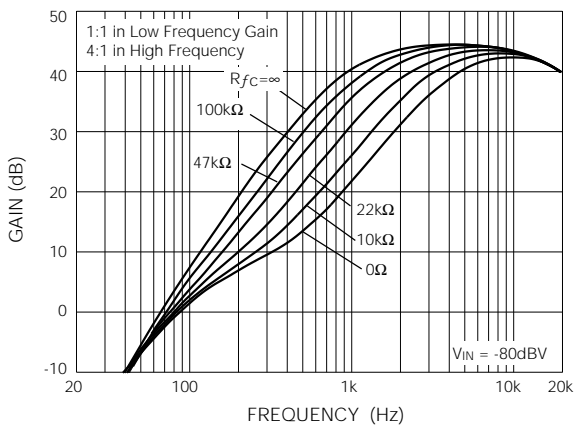

Fig. 15 GB570 Frequency Response for Different R_{fc} Resistor Values

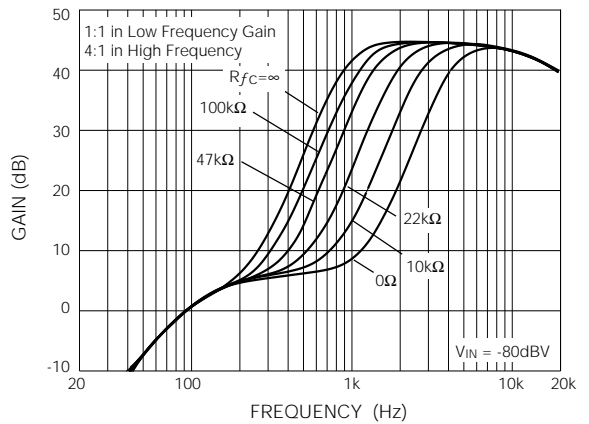

Fig. 16 GC570 Frequency Response for Different R_{fc} Resistor Values

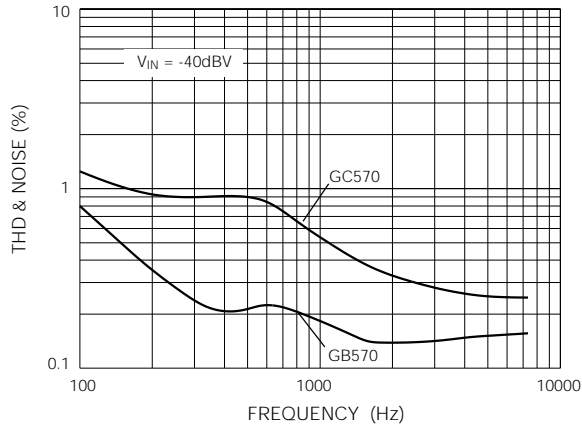

Fig. 17 THD and Noise vs Frequency

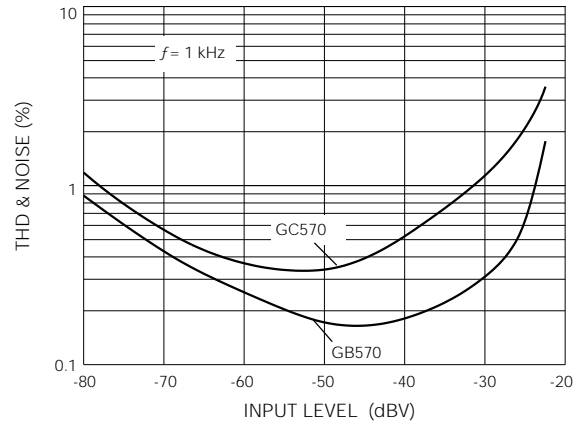

Fig. 18 THD and Noise vs Input Level

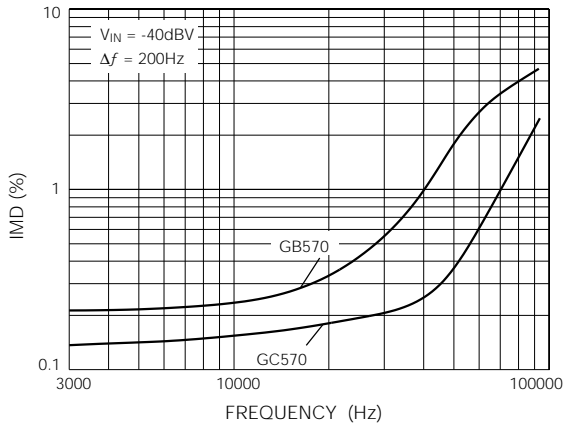

Fig. 19 Intermodulation Distortion (CCIF) vs Frequency

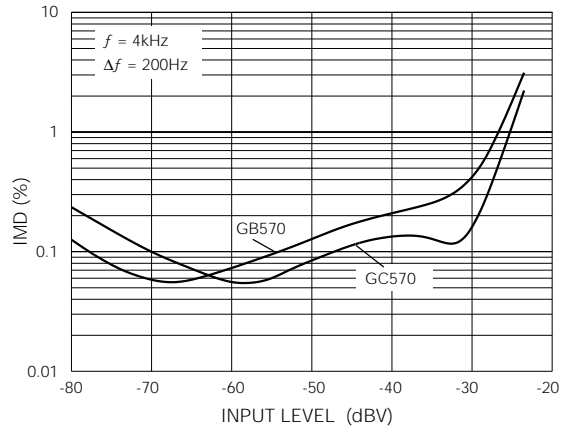

Fig. 20 Intermodulation Distortion (CCIF) vs Input Level

GENNUM CORPORATION
 MAILING ADDRESS:
 P.O. Box 489, Stn. A, Burlington, Ontario, Canada L7R 3Y3
 Tel. +1 (905) 632-2996 Fax +1 (905) 632-2814
 SHIPPING ADDRESS:
 970 Fraser Drive, Burlington, Ontario, Canada L7L 5P5

GENNUM JAPAN CORPORATION
 C-101, Miyamae Village, 2-10-42 Miyamae, Suginami-ku, Tokyo 168-0081,
 Japan Tel. +81 (3) 3334-7700 Fax: +81 (3) 3247-8839

DOCUMENT IDENTIFICATION: DATA SHEET
 The product is in production. Gennum reserves the right to make changes at any time to improve reliability, function or design, in order to provide the best product possible.

REVISION NOTES:
 New Document.