

FEATURES

- 300/255 MIPs SLIMD™ DSP Architecture
- DirectX™ 5.0 3D Positional Audio
- Fat Labs Approved 64-Voice Wavetable Synthesis with Effects
- NetMeeting™ AEC Hardware Acceleration
- Dolby® Digital AC-3® (CS4622)
- High Quality Hardware Sample Rate Conversion (90+ dB Dynamic Range)
- PC/PCI Legacy Support
- DDMA Legacy Support
- CrystalClear Legacy Support (CCLS™)
- PCI 2.1 Compliant PCI Interface
- 96 Stream DMA Interface with Hardware Scatter/Gather Support
- PCI Power Management (D0 through D3 Hot), APM 1.2, and ACPI 1.0 Support
- AC '97 2.0 Link Codec Interface
- Secondary AC '97 1.0/2.0 Link Codec Interface for Multi-Channel and Digital Docking Support
- Asynchronous Digital Serial Interface (ZV Port)
- S/PDIF Digital Input and Output Interfaces supporting both PCM and Dolby Digital 5.1 Formats
- MPU-401 MIDI Input/Output Interface
- 3.3 V Power Supply (5 V tolerant I/O)

ORDERING INFORMATION

CS4622-CQ 128-pin TQFP 20x14x1.60 mm
CS4624-CQ 128-pin TQFP 20x14x1.60 mm

**CrystalClear™
SoundFusion™ PCI Audio
Accelerator**

DESCRIPTION

The CS4622/24 is a high performance pin-compatible upgrade to the 128-pin CS4610C PCI audio accelerator. With the added legacy compatibility modes, the CS4622/24 enables real mode DOS compatible PCI-only audio subsystems. This device, combined with application and driver software, provides a complete system solution for hardware acceleration of Windows 95® DirectSound®, DirectSound3D®, DirectInput, and Wavetable Synthesis. WDM drivers provide support for both Windows 98 and Windows NT 5.0.

The CS4622/24 is based on the Cirrus Logic CrystalClear Stream Processor (SP) DSP core. The SP core is optimized for digital audio processing, and is powerful enough to handle complex signal processing tasks such as Dolby Digital AC-3 decoding (CS4622 only) with ease. The SP core is supported by a bus mastering PCI interface and a built-in dedicated DMA engine with hardware scatter-gather support. These support functions ensure extremely efficient transfer of audio data streams to and from host-based memory buffers, providing a system solution with maximum performance and minimal host CPU loading.

The all-digital CS4622/24 supports a variety of audio I/O configurations including direct connection to the CrystalClear CS4297 AC '97 Codec. A secondary AC '97 2.0 interface provides support for multi-channel and digital docking solutions. Added extended I/O supports DAA control for modem applications.

Consumer Digital input and output (S/PDIF) interfaces support both PCM and compressed 5.1 digital data formats.

PC/PCI, DDMA, and CrystalClear Legacy support provide PCI-only legacy games compatibility.

ABSOLUTE MAXIMUM RATINGS

(PCIGND = CGND = CRYGND = 0 V, all voltages with respect to 0 V)

Parameter	Symbol	Min	Typ	Max	Unit
Power Supplies	PCIVDD	-	-	4.6	V
	CVDD	-	-	4.6	V
	CRYVDD	-	-	4.6	V
	VDD5REF	-	-	5.5	V
Total Power Dissipation (Note 1)		-	-	1.5	W
Input Current per Pin, DC (Except supply pins)		-	-	10	mA
Output current per pin, DC		-	-	10	mA
Input voltage (Note 2)		-0.3	-	5.75	V
Ambient temperature (power applied) (Note 3)		-45	-	85	°C
Storage temperature		-55	-	150	°C

- Notes: 1. Includes all power generated by AC and/or DC output loading.
 2. The power supply pins are at recommended maximum values. XTALI & XTALO are at 3.6 V maximum.
 3. At ambient temperatures above 70° C, total power dissipation must be limited to less than 0.4 Watts.

WARNING: Operation beyond these limits may result in permanent damage to the device.
 Normal operation is not guaranteed at these extremes.

RECOMMENDED OPERATING CONDITIONS

(PCIGND = CGND = CRYGND = 0 V, all voltages with respect to 0 V)

Parameter	Symbol	Min	Typ	Max	Unit
Power Supplies	PCIVDD	3	3.3	3.6	V
	CVDD	3	3.3	3.6	V
	CRYVDD	3	3.3	3.6	V
	VDD5REF	4.75	5	5.25	V
Internal DSP Frequency		-	-	85	MHz
Operating Ambient Temperature	T _A	0	25	70	°C

Specifications are subject to change without notice.

Dolby's AC-3 Technology is implemented on the CS4622 Stream Processor Only. Supply of this Implementation of Dolby Technology does not convey a license nor imply a right under any patent, or any other Industrial or Intellectual Property Right of Dolby Laboratories, to use this Implementation in any finished end-user or ready-to-use final product. It is hereby notified that a license for such use is required from Dolby Laboratories.

Dolby and AC-3 are registered trademarks of Dolby Laboratories Licensing Corporation.
 Windows, Windows 95, DirectSound, and DirectSound3D are registered trademarks of Microsoft Corporation.
 DirectInput, DirectX and NetMeeting are trademarks of Microsoft Corporation.
 Sound Blaster and Sound Blaster Pro are trademarks of Creative Technology, Ltd.
 Crystal, CrystalClear, CCLS, SLIMD and SoundFusion are trademarks of Cirrus Logic, Inc.
 All other names are trademarks, registered trademarks, or service marks of their respective companies.

AC CHARACTERISTICS (PCI SIGNAL PINS ONLY) (T_A = 70° C;

PCIVDD = CVDD = CRYVDD = 3.3 V; VDD5REF = 5 V; PCIGND = CGND = CRYGND = 0 V;

Logic 0 = 0 V, Logic 1 = 3.3 V; Reference levels = 1.4 V; unless otherwise noted; (Note 4))

Parameter	Symbol	Min	Max	Unit
Switching Current High (Note 5) 0 < Vout < 1.4 1.4 < Vout < 2.4 3.1 < Vout < 3.3	I _{OH}	-44	-	mA
		$-44 + \frac{V_{out} - 1.4}{0.024}$	-	mA
		-	Note 7	
Switching Current Low (Note 5) Vout > 2.2 2.2 > Vout > 0.55 0.71 > Vout > 0	I _{OL}	95	-	mA
		Vout/0.023	-	mA
		-	Note 8	
Low Clamp Current -5 < Vin < -1	I _{CL}	$-25 + \frac{V_{in} + 1}{0.015}$	-	mA
Output rise slew rate 0.4 V - 2.4 V load (Note 6)	slewr	1	5	V/ns
Output fall slew rate 2.4 V - 0.4 V load (Note 6)	slewf	1	5	V/ns

- Notes:
- Specifications guaranteed by characterization and not production testing.
 - Refer to V/I curves in Figure 1. Specification does not apply to PCICLK and RST# signals. Switching Current High specification does not apply to SERR#, PME#, and INTA# which are open drain outputs.
 - Cumulative edge rate across specified range. Rise slew rates do not apply to open drain outputs.
 - Equation A: I_{OH} = 11.9 * (Vout - 5.25) * (Vout + 2.45) for 3.3 V > Vout > 3.1 V
 - Equation B: I_{OL} = 78.5 * Vout * (4.4 - Vout) for 0 V < Vout < 0.71 V

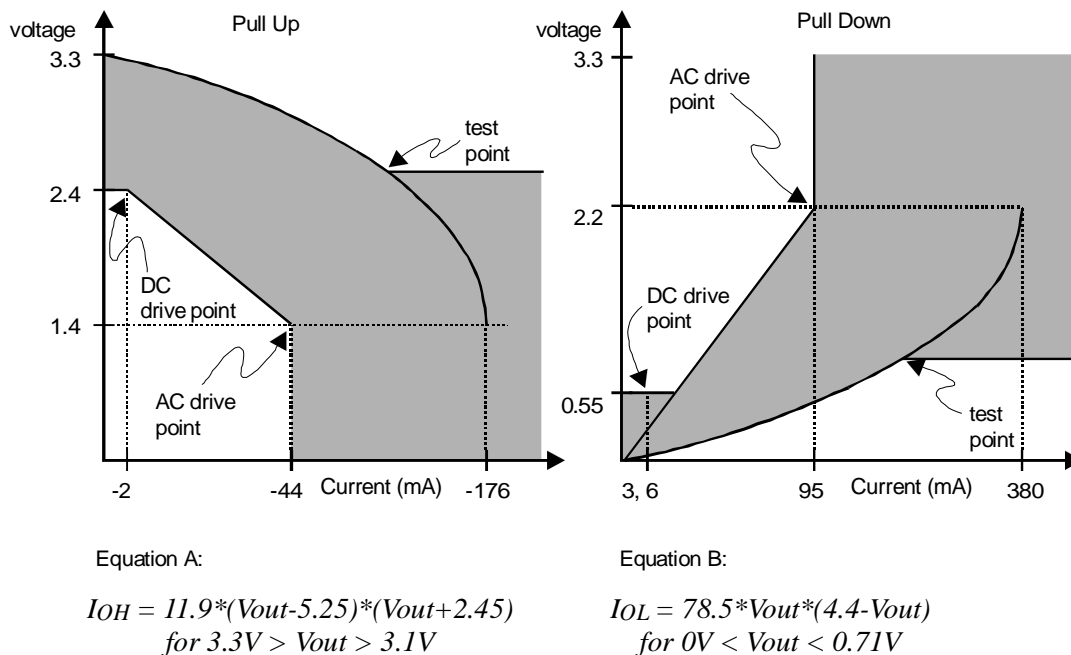

Figure 1. AC Characteristics

DC CHARACTERISTICS ($T_A = 70^\circ \text{C}$; PCIVDD = CVDD = CRYVDD = 3.3 V; VDD5REF = 5 V;
 PCIGND = CGND = CRYGND = 0 V; all voltages with respect to 0 V unless otherwise noted)

Parameter	Symbol	Min	Typ	Max	Unit
PCI Interface Signal Pins					
High level input voltage	V_{IH}	2	-	5.75	V
Low level input voltage	V_{IL}	-0.5	-	0.8	V
High level output voltage Iout = -2 mA	V_{OH}	2.4	-	-	V
Low level output voltage Iout = 3 mA, 6 mA (Note 9)	V_{OL}	-	-	0.55	V
High level leakage current Vin = 2.7 V (Note 10)	I_{IH}	-	-	70	μA
Low level leakage current Vin = 0.5 V (Note 10)	I_{IL}	-	-	-70	μA
Non-PCI Interface Signal Pins (Except XTALO)					
High level input voltage	XTALI	2.3	3.3	4.0	V
	Other Pins	2	-	5.75	V
Low level input voltage	XTALI	-0.5	0	0.8	V
	Other Pins	-0.5	-	0.8	V
High level output voltage Iout = -4 mA (Note 11)	V_{OH}	2.4	-	-	V
Low level output voltage Iout = 4 mA	V_{OL}	-	-	0.4	V
High level leakage current Vin = 5.25 V	I_{IH}	-	-	10	μA
Low level leakage current Vin = 0	I_{IL}	-	-	-10	μA

Parameter	Min	Typ	Max	Unit
Power Supply Pins (Outputs Unloaded)				
Power Supply Current: VDD5REF	-	0.6	-	mA
PCIVDD/CVDD/CRYVDD Total (Notes 4,12)	-	164	TBD	mA
Low Power Mode Supply Current	-	10	-	mA

- Notes: 9. The following signals are tested to 6 mA: FRAME#, TRDY#, IRDY#, DEVSEL#, STOP#, SERR#, PERR#, and INTA#. All other PCI interface signals are tested to 3 mA.
10. Input leakage currents include hi-Z output leakage for all bi-directional buffers with three-state outputs.
11. For open drain pins, high level output voltage is dependent on external pull-up used and number of attached gates.
12. Typical values are given as average current with typical SP task execution and data streaming. Current values vary dramatically based on the software running on the SP.

PCI INTERFACE PINS ($T_A = 0$ to 70°C ; $\text{PCIVDD} = \text{CVDD} = \text{CRYVDD} = 3.3\text{V}$; $\text{VDD5REF} = 5\text{V}$; $\text{PCIGND} = \text{CGND} = \text{CRYGND} = 0\text{V}$; Logic 0 = 0 V, Logic 1 = 3.3 V; Timing reference levels = 1.4 V)

Parameter	Symbol	Min	Max	Unit
PCICLK cycle time	t_{cyc}	30	-	ns
PCICLK high time	t_{high}	11	-	ns
PCICLK low time	t_{low}	11	-	ns
PCICLK to signal valid delay - bused signals	t_{val}	2	11	ns
PCICLK to signal valid delay - point to point	$t_{\text{val(p+p)}}$	2	12	ns
Float to active delay (Note 13)	t_{on}	2	-	ns
Active to Float delay (Note 13)	t_{off}	-	28	ns
Input Set up Time to PCICLK - bused signals	t_{su}	7	-	ns
Input Set up Time to PCICLK - point to point	$t_{\text{su(p+p)}}$	10, 12	-	ns
Input hold time for PCICLK	t_{h}	0	-	ns
Reset active time after PCICLK stable (Note 14)	$t_{\text{rst-clk}}$	100	-	μs
Reset active to output float delay (Notes 13, 14, 15)	$t_{\text{rst-off}}$	-	40	ns

- Notes: 13. For Active/Float measurements, the Hi-Z or “off” state is when the total current delivered is less than or equal to the leakage current. Specification is guaranteed by design, not production tested.
 14. RST# is asserted and de-asserted asynchronously with respect to PCICLK.
 15. All output drivers are asynchronously floated when RST# is active.

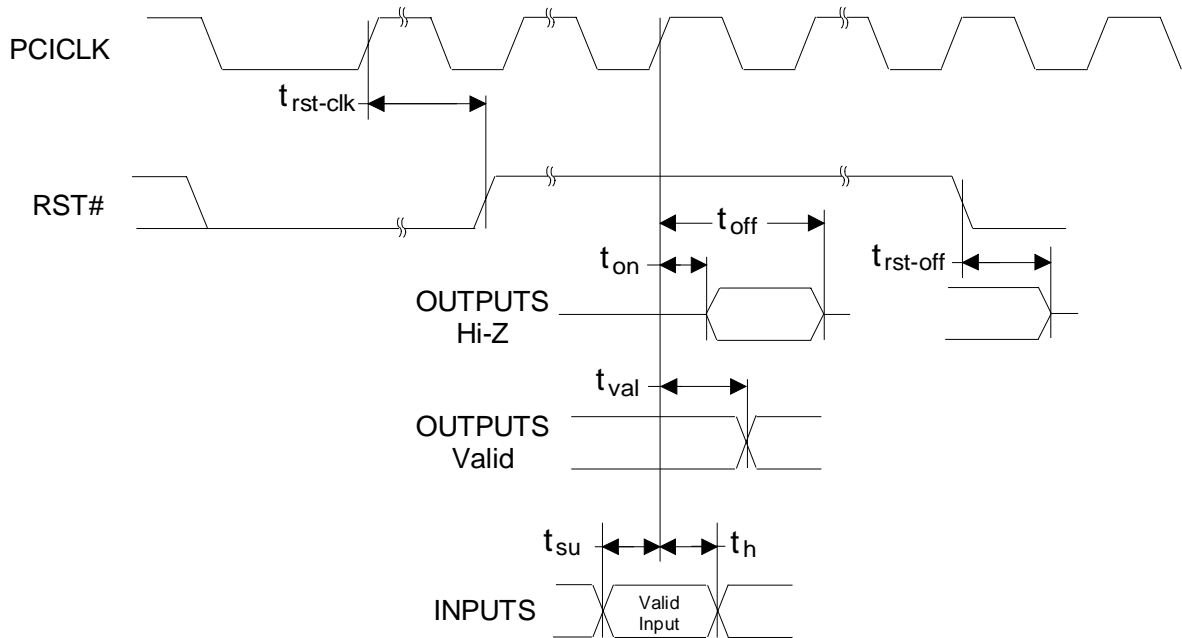

Figure 2. PCI Timing Measurement Conditions

AC '97 SERIAL INTERFACE TIMING ($T_A = 0$ to 70°C ; $\text{PCIVDD} = \text{CVDD} = \text{CRYVDD} = 3.3\text{ V}$; $\text{VDD5REF} = 5\text{ V}$; $\text{VDD5REF} = 5\text{ V}$; $\text{PCIGND} = \text{CGND} = \text{CRYGND} = 0\text{ V}$; Logic 0 = 0 V, Logic 1 = 3.3 V; Timing reference levels = 1.4 V; unless otherwise noted)

Parameter	Symbol	Min	Typ	Max	Unit
ABITCLK/ABITCLK2 cycle time	t_{aclk}	78	81.4	-	ns
ABITCLK/ABITCLK2 rising to ASDOUT/ADSOUT2 valid	t_{pd5}	-	17	25	ns
ASDIN/ASDIN2 valid to ABITCLK/ABITCLK2 falling	t_{s5}	15	-	-	ns
ASDIN/ASDIN2 hold after ABITCLK/ABITCLK2 falling	t_{h5}	5	-	-	ns
PCICLK rising to ARST#/ARST2# valid	t_{pd6}	-	10	-	ns

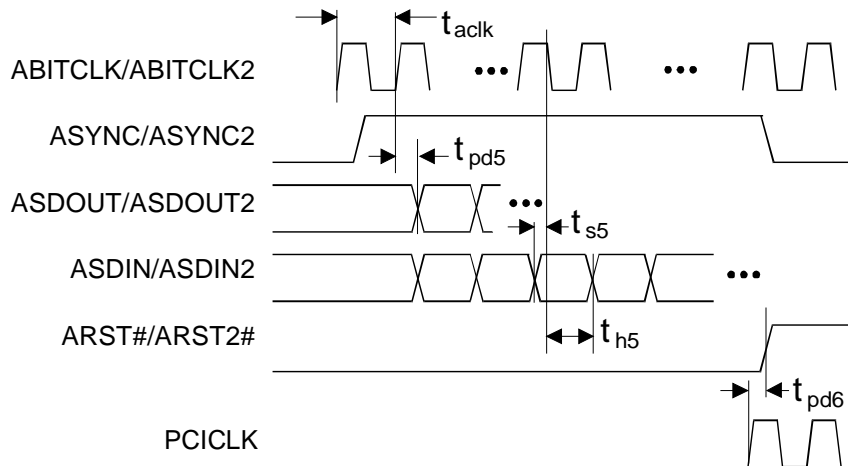

Figure 3. AC '97 Configuration Timing Diagram

ZV PORT TIMING

Parameter	Symbol	Min	Max	Unit
ZLRCK delay after ZSCLK rising	t_{slrd}	2	-	ns
ZLRCK setup before ZSCLK rising	t_{slrs}	32	-	ns
ZSCLK low period	t_{sclk}	22	-	ns
ZSCLK high period	t_{sclkh}	22	-	ns
ZSDATA setup to ZSCLK rising	t_{sdlrs}	32	-	ns
ZSDATA hold after ZSCLK rising	t_{sdh}	2	-	ns

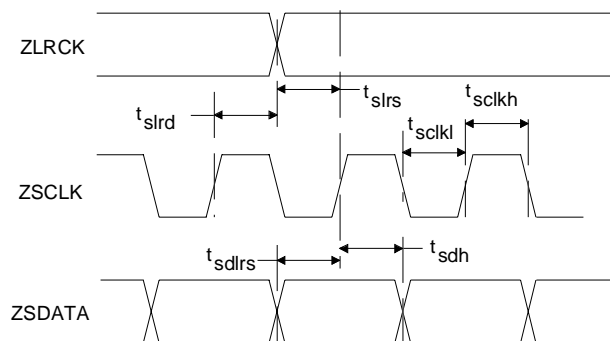

Figure 4. ZV PORT

INDEPENDENT TIMING ENVIRONMENT ($T_A = 0$ to 70°C ; $\text{PCIVDD} = \text{CVDD} = \text{CRYVDD} = 3.3\text{ V}$; $\text{VDD5REF} = 5\text{ V}$; $\text{VDD5REF} = 5\text{ V}$; $\text{PCIGND} = \text{CGND} = \text{CRYGND} = 0\text{ V}$; Logic 0 = 0V, Logic 1 = 3.3 V; Timing reference levels = 1.4 V; XTALI = 12.288 MHz; unless otherwise noted)

Parameter	Symbol	Min	Typ	Max	Units
SCLK output cycle time	t_{sclk}	312	326	-	ns
FSYNC output cycle time (@SCLK falling edge)	t_{fsync}	20000	20833	-	ns
SCLK falling to FSYNC transition	t_{pd7}	-45	2	45	ns
LRCLK output cycle time (@ SCLK rising edge)	t_{lrclk}	20000	20833	-	ns
SCLK rising to LRCLK transition	t_{pd8}	-45	2	45	ns
SCLK falling to SDOUT/SDO2/SDO3 valid	t_{pd9}	-	2	45	ns
SDIN/SDIN2 valid to SCLK rising (SI1F2-0: 010, SI2F1-0: 00)	t_{s6}	30	-	-	ns
SDIN/SDIN2 hold after SCLK rising (SI1F2-0: 010, SI2F1-0: 00)	t_{h6}	30	-	-	ns
SDIN/SDIN2 valid to SCLK falling (SI1F2-0: 011, SI2F1-0: 01)	t_{s7}	30	-	-	ns
SDIN/SDIN2 hold after SCLK falling (SI1F2-0: 011, SI2F1-0: 01)	t_{h7}	30	-	-	ns
XTAL frequency		12.287	12.288	12.289	MHz
XTALI high time (Note 4)		35	-	-	ns
XTALI low time (Note 4)		35	-	-	ns
MCLK output frequency (Note 4)		12.287	12.288	12.289	MHz

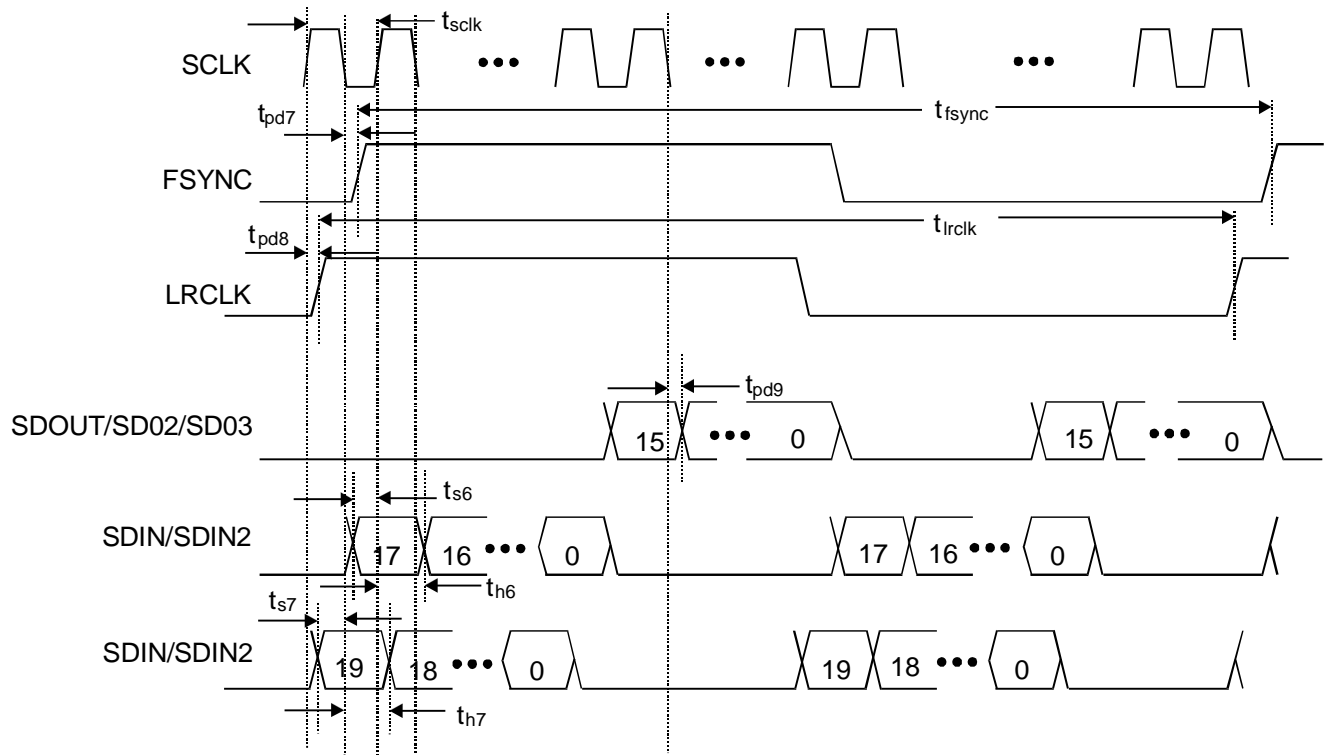

Figure 5. Independent Timing Configuration

EEPROM TIMING CHARACTERISTICS Note 4. ($T_A = 0$ to 70 °C, $PCIVDD = CVDD = CRYVDD = 3.3$ V; $VDD5REF = 5$ V; $VDD5REF = 5$ V; $PCIGND = CGND = CRYGND = 0$ V; Logic 0 = 0 V, Logic 1 = 3.3 V; Timing reference levels = 1.4 V; PCI clock frequency = 33 MHz; unless otherwise noted)

Parameter	Symbol	Min	Max	Units
EECLK Low to EEDAT Data Out Valid	t_{AA}	0	7.0	μ s
Start Condition Hold Time	$t_{HD:STA}$	5.0	-	μ s
EECLK Low	t_{LEECLK}	10	-	μ s
EECLK High	t_{HEECLK}	10	-	μ s
Start Condition Setup Time (for a Repeated Start Condition)	$t_{SU:STA}$	5.0	-	μ s
EEDAT In Hold Time	$t_{HD:DAT}$	0	-	μ s
EEDAT In Setup Time	$t_{SU:DAT}$	250	-	ns
EEDAT/EECLK Rise Time (Note 16)	t_R	-	1	μ s
EEDAT/EECLK Fall Time	t_F	-	300	ns
Stop Condition Setup Time	$t_{SU:STO}$	5.0	-	μ s
EEDAT Out Hold Time	t_{DH}	0	-	μ s

Notes: 16. Rise time on EEDAT is determined by the capacitance on the EEDAT line with all connected gates and the required external pull-up resistor.

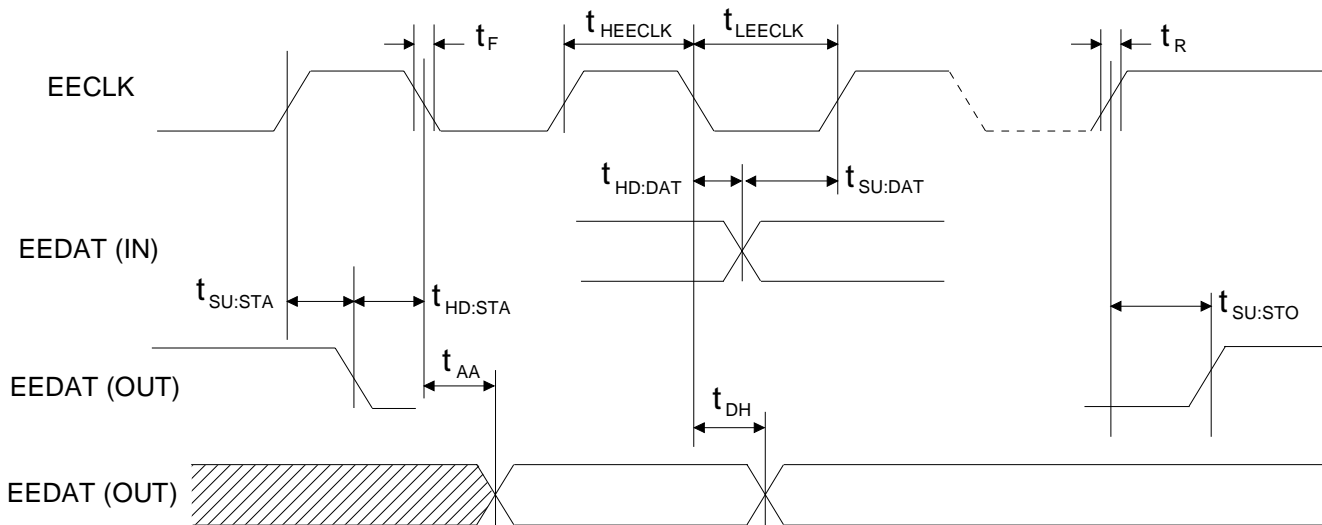

Figure 6. EEPROM Timing

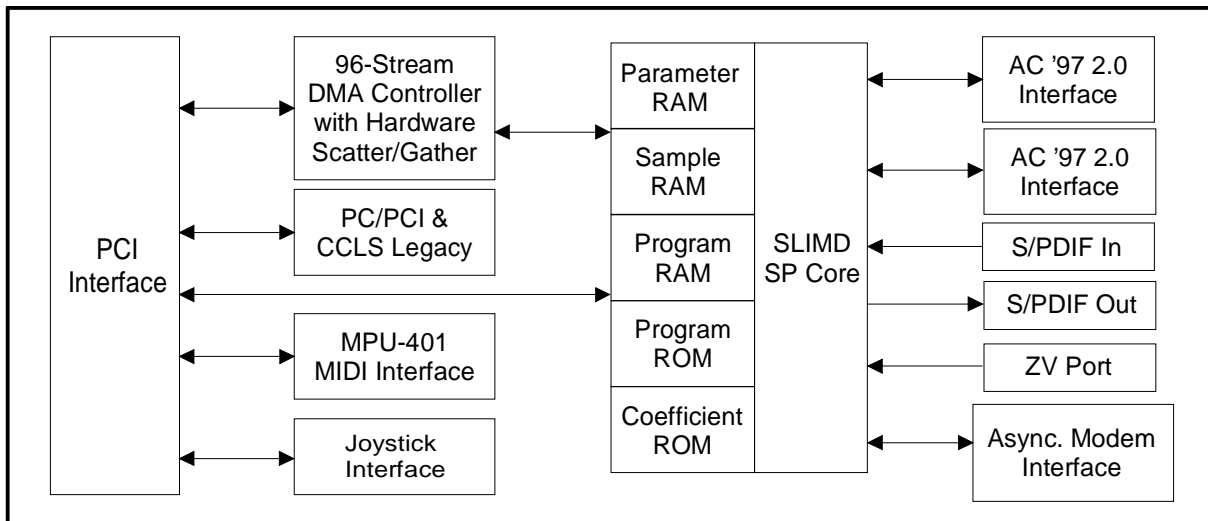

Figure 7. CS4622/24 Block Diagram

OVERVIEW

The CS4622/24 is a high performance audio accelerator DSP for the PCI bus. This device, combined with application and driver software, provides a complete system solution for cost effective acceleration of Windows DirectSound, Direct-Sound3D, DirectInput, MIDI playback via Wavetable Synthesis with reverberation and chorus effects processing, and more. The CS4622/24 is compatible with the CS4610C with the following added features:

- Primary AC '97 Interface now 2.0 compatible
- 2nd AC '97 Interface (also 2.0 compliant)
- CrystalClear Legacy Support
- PC/PCI Legacy Support
- DDMA Legacy Support
- PCI Power Management Event Support
- ZV Port Asynchronous Serial Port
- 2nd Asynchronous Serial Port
- 9 Extended GPIO pins for Modem Support
- Consumer Digital (S/PDIF) Input and Output

The CS4622 is a high-performance, full-featured version of the SoundFusion audio accelerator. The CS4624 is a reduced-cost version of the CS4622.

The CS4624 has a lower maximum clock speed and does not support AC-3. Please refer to the *OEM Software Reference Manual* for more details.

There are three main functional blocks within the CS4622/24: the Stream Processor, the PCI Interface, and the DMA Engine. A block diagram of the CS4622/24 device is shown in Figure 7.

The Stream Processor (SP) is a high speed custom Digital Signal Processor (DSP) core specifically designed for audio signal processing. This extremely powerful DSP core is capable of running complex algorithms such as Dolby Digital AC-3 audio decoding for applications such as DVD movie playback or gaming. The Stream Processor is capable of running a number of different signal processing algorithms simultaneously. This high concurrency capability is valuable for applications such as immersive 3D games, which may play a number of DirectSound streams, a number of DirectSound3D streams, and a MIDI music sequence simultaneously.

Separate RAM memories are included on-chip for the SP program code (PROGRAM RAM), parameter data (PARAMETER RAM), and audio sample data (SAMPLE RAM). Two ROM memories store

coefficients for sample rate conversion and audio decompression algorithms (COEFFICIENT ROM) and common algorithm code (PROGRAM ROM).

The RAM-based DSP architecture of the CS4622/24 ensures maximum system flexibility. The software function/feature mix can be adapted to meet the requirements of a variety of different applications, such as DirectX™ games, DVD movie playback, or DOS applications. This RAM-based architecture also provides a means for future system upgrades, allowing the addition of new or upgraded functionality through software updates.

The CS4622/24 provides an extremely efficient bus mastering interface to the PCI bus. The PCI Interface function allows economical burst mode transfers of audio data between host system memory buffers and the CS4622/24 device. Program code and parameter data are also transferred to the CS4622/24 over the PCI interface.

The DMA Engine provides dedicated hardware to manage transfer of up to 96 concurrent audio/data streams to and from host memory buffers. The DMA Engine provides hardware scatter-gather support, allowing simple buffer allocation and management. This implementation improves system efficiency by minimizing the number of host interrupts.

The CS4622/24 supports a variety of audio I/O configurations including a single CS4297 CrystalClear AC '97 Codec or dual CS4297 codecs where the second codec is used as a modem analog front end or resides in a portable's docking station. The system's flexibility is further enhanced by the inclusion of a bi-directional serial MIDI port, a joystick port, a hardware volume control interface, a ZV Port interface, and a serial data port which allows connection of an optional external EEPROM device.

Stream Processor DSP Core

The CS4622/24 Stream Processor (SP) is a custom DSP core design which is optimized for processing and synthesizing digital audio data streams. The SP features a Somewhat Long Instruction Multiple Data (SLIMD) modified dual Harvard architecture. The device uses a 40-bit instruction word and operates on 32-bit data words. The SP includes two Multiply-Accumulate (MAC) blocks and one 16-bit Arithmetic and Logic Unit (ALU). The SP core is conservatively rated at 300 Million Instructions per second (300 MIPS) when running at a 100 MHz internal clock speed (CS4624 runs at 85 MHz). The MAC units perform dual 20-bit by 16-bit multiplies and have 40-bit accumulators, providing higher quality than typical 16-bit DSP architectures.

A programmable Phase Locked Loop (PLL) circuit generates the high frequency internal SP clock from a lower frequency input clock. The input to the PLL may be from a crystal oscillator circuit or the serial port clock ABITCLK/SCLK. Clock control circuitry allows gating of clocks to various internal functional blocks to conserve power during power conservation modes, as well as during normal modes of operation when no tasks are being executed.

Legacy Support

Legacy games are supported by CrystalClear Legacy Support (CCLS), DDMA, or by the PC/PCI interface.

In both motherboard and add-in card designs, CCLS and DDMA provide support for legacy games by providing a hardware interface that supports a Sound Blaster Pro compatible interface, as well as support for FM, MPU-401, and joystick interfaces. These hardware interfaces provide PCI-only games compatibility for real-mode DOS and Windows DOS-box support.

For motherboard designs, PC/PCI can be used by connecting the PCGNT# and PCREQ# pins to the

appropriate pins on the south bridge motherboard chip. The PC/PCI interface is compliant with Intel's PC/PCI spec. (version 1.2). The BIOS must enable the PC/PCI mechanism at boot time on both the CS4622/24 and the south bridge.

SYSTEM ARCHITECTURES

A typical system diagram depicting connection of the CS4622/24 to the CrystalClear CS4297 AC '97 Codec is given in Figure 8. All analog audio inputs and outputs are connected to the CS4297. Audio data is passed between the CS4297 and the CS4622/24 over the serial AC-Link. The CS4622/24 provides a hardware interface for connection of a joystick and MIDI devices.

A second diagram (Figure 9) depicts the CS4622/24 using both AC '97 codec interfaces in a portable design. The primary AC '97 interface is connected to a CS4297 in the portable and is used for all audio I/O inside and connected to the portable. The second AC '97 interface is sent across to the docking station which contains a second CS4297, used when the portable is in the docking station. Software can disable the audio I/O paths on the portable that are superseded by docking station I/O and enable the paths needed in the docking station. Note that both interfaces are needed in systems where the CD-ROM analog input is in the portable and the Line In/Out jacks on the docking

stations are used. Using the AC '97 digital link across the dock maintains the absolute highest audio quality along with a standard well-defined non-proprietary interface that will last through many system generations.

A third diagram (Figure 10) depicts the CS4622/24 using both AC '97 codec interfaces in a modem design. The primary AC '97 interface is connected to a CS4297 and is used for all traditional audio I/O such as Mic In, Line In, and Line Out. The second AC '97 interface is connected to a second CS4297 and is used as the Analog Front End (AFE) for the Modem. The second CS4297 analog interface is connected to the DAA analog. The DAA digital control is accomplished using the EGPIO pins on the CS4622/24. The EGPIO supports the PCI Power Management Event system wake-up feature allowing a powered-down system to be powered up by an incoming call on the modem.

HOST INTERFACE

The CS4622/24 host interface is comprised of two separate interface blocks which are memory mapped into host address space. The interface blocks can be located anywhere in the host 32-bit physical address space. The interface block locations are defined by the addresses programmed into the two Base Address Registers in the PCI Configuration Space. These base addresses are normally

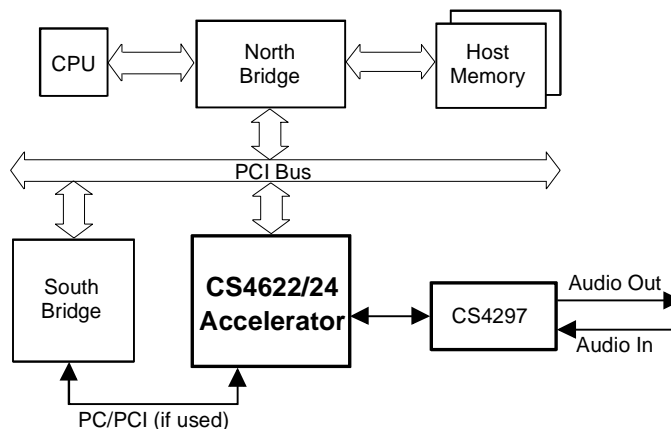

Figure 8. AC '97 Codec Interface

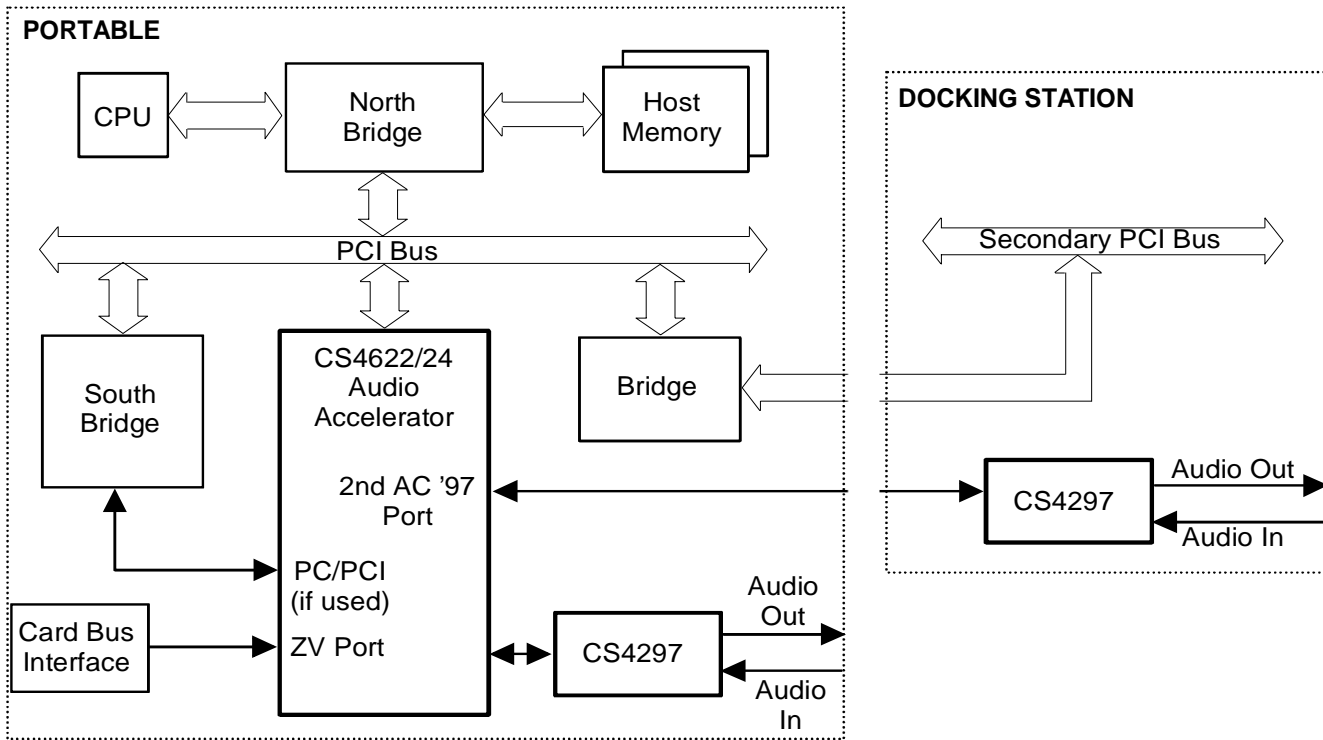

Figure 9. Portable Docking Station Scenario

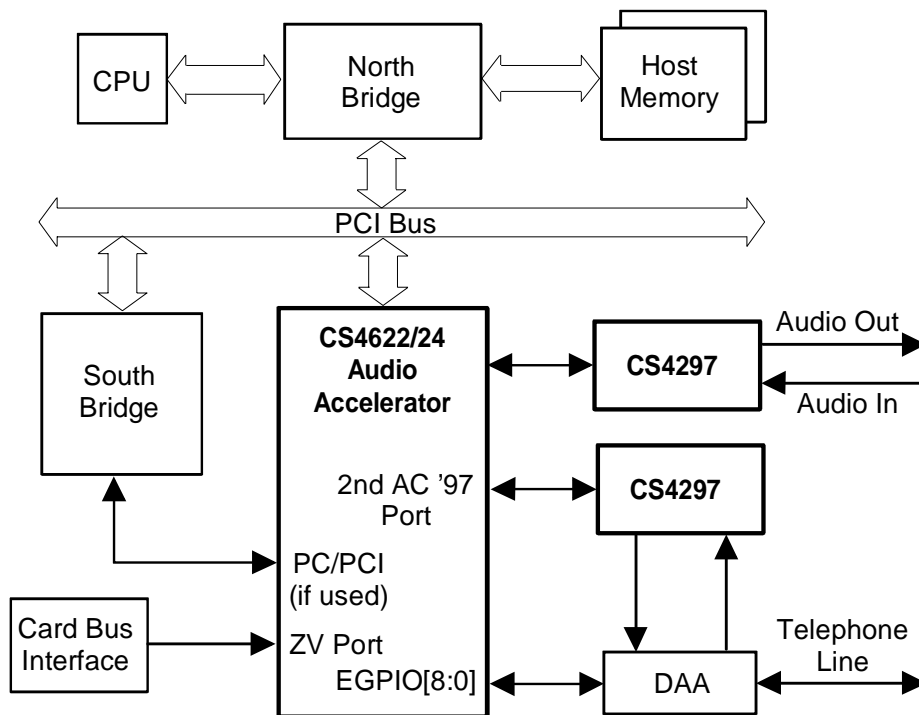

Figure 10. Modem Scenario

set up by the system's Plug and Play BIOS. The first interface block (located by Base Address 0) is a 4 kByte register block containing general purpose configuration, control, and status registers for the device. The second interface block (located by Base Address 1) is a 1 MByte block which maps all of the internal RAM memories (SP Program RAM, Parameter RAM, and Sample RAM) into host memory space. This allows the host to directly peek and poke RAM locations on the device. The relationship between the Base Address Registers in the CS4622/24 PCI Configuration Space and the host memory map is depicted in Figure 11.

The bus mastering PCI bus interface complies with the PCI Local Bus Specification (version 2.1).

PCI bus transactions

As a target of a PCI bus transaction, the CS4622/24 supports the Memory Read (from internal registers or memory), Memory Write (to internal registers or memory), Configuration Read (from CS4622/24 configuration registers), Configuration Write (to CS4622/24 configuration registers), Memory Read Multiple (aliased to Memory Read), Memory Read Line (aliased to Memory Read), and the Memory Write and Invalidate (aliased to Memory Write) transfer

cycles. The I/O Read, I/O Write, Interrupt Acknowledge, Special Cycles, and Dual Address Cycle transactions are not supported.

As Bus Master, the CS4622/24 generates the Memory Read Multiple and Memory Write transactions. The Memory Read, Configuration Read, Configuration Write, Memory Read Line, Memory Write and Invalidate, I/O Read, I/O Write, Interrupt Acknowledge, Special Cycles, and Dual Address Cycle transactions are not generated.

The PCI bus transactions supported by the CS4622/24 device are summarized in Table 1. Note that no Target Abort conditions are signalled by the device. Byte, Word, and Doubleword transfers are supported for Configuration Space accesses. Only Doubleword transfers are supported for Register or Memory area accesses. Bursting is not supported for host-initiated transfers to/from the CS4622/24 internal register space, RAM memory space, or PCI configuration space (disconnect after first phase of transaction is completed).

Configuration Space

The content and format of the PCI Configuration Space is given in Table 2.

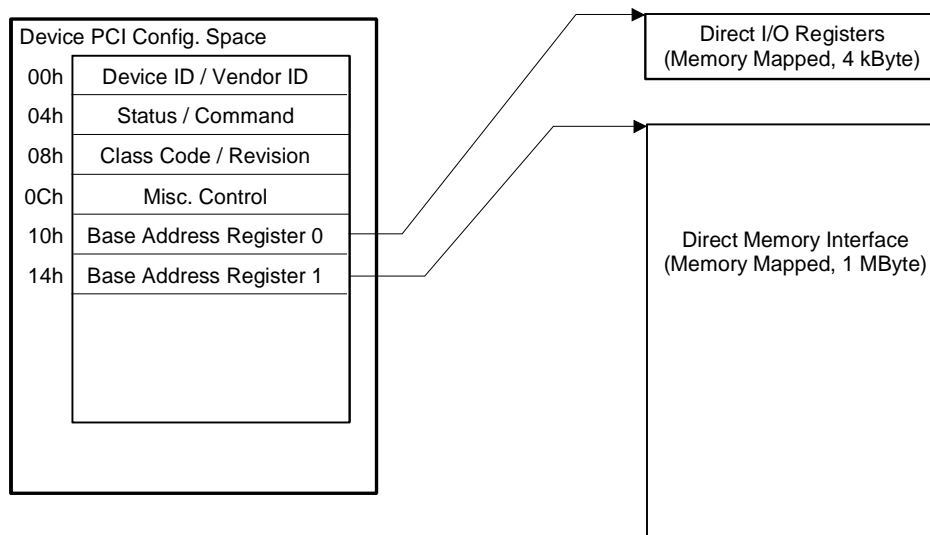

Figure 11. Host Interface Base Address Registers

Initiator	Target	Type	PCI Dir
Host	Registers (BA0)	Mem Write	In
Host	Registers (BA0)	Mem Read	Out
Host	Memories (BA1)	Mem Write	In
Host	Memories (BA1)	Mem Read	Out
Host	Config Space 1	Config Write	In
Host	Config Space 1	Config Read	Out
DMA	Host System	Mem Write	Out
DMA	Host System	Mem Read	In

Table 1. PCI Interface Transaction Summary

Byte 3	Byte 2	Byte 1	Byte 0	Offset
Device ID: R/O, 6003h		Vendor ID: R/O, 1013h		00h
Status Register, bits 15-0: Bit 15 Detected Parity Error: Error Bit Bit 14 Signalled SERR: Error Bit Bit 13 Received Master Abort: Error Bit Bit 12 Received Target Abort: Error Bit Bit 11 Signalled Target Abort: Error Bit Bit 10-9 DEVSEL Timing: R/O, 01b (medium) Bit 8 Data Parity Error Detected: Error Bit Bit 7 Fast Back to Back Capable: R/O 0 Bit 6 User Definable Features: R/O 0 Bit 5 66MHz Bus: R/O 0 Bit 4 New Capabilities: R/O 1 Bit 3-0 Reserved: R/O 0000 Reset Status State: 0210h Write of 1 to any error bit position clears it.		Command Register, bits 15-0: Bit 15-10: Reserved, R/O 0 Bit 9 Fast B2B Enable: R/O 0 Bit 8 SERR Enable: R/W, default 0 Bit 7 Wait Control: R/O 0 Bit 6 Parity Error Response: R/W, default 0 Bit 5 VGA Palette Snoop: R/O 0 Bit 4 MWI Enable: R/O 0 Bit 3 Special Cycles: R/O 0 Bit 2 Bus Master Enable: R/W, default 0 Bit 1 Memory Space Enable: R/W, default 0 Bit 0 IO Space Enable: R/O 0		04h
Class Code: R/O 040100h Class 04h (multimedia device), Sub-class 01h (audio), Interface 00h			Revision ID: R/O 01h	08h
BIST: R/O 0	Header Type: Bit 7: R/O 0 Bit 6-0: R/O 0 (type 0)	Latency Timer: Bit 7-3: R/W, default 0 Bit 2-0: R/O 0	Cache Line Size: R/O 0	0Ch
Base Address Register 0 Device Control Register space, memory mapped. 4 kByte size Bit 31-12: R/W, default 0. Compare address for register space accesses Bit 11 - 4: R/O 0, specifies 4 kByte size Bit 3: R/O 0, Not Prefetchable (Cacheable) Bit 2-1: R/O 00, Location Type - Anywhere in 32 bit address space Bit 0: R/O 0, Memory space indicator				10h

Table 2. PCI Configuration Space

Byte 3	Byte 2	Byte 1	Byte 0	Offset
Base Address Register 1 Device Memory Array mapped into host system memory space, 1 MByte size Bit 31-20: R/W, default 0. Compare address for memory array accesses Bit 19 - 4: R/O 0, specifies 1 MByte size Bit 3: R/O 0, Not Prefetchable (Cacheable) Bit 2-1: R/O 00, Location Type - Anywhere in 32 bit address space Bit 0: R/O 0, Memory space indicator				14h
Base Address Register 2: R/O 00000000h, Unused				18h
Base Address Register 3: R/O 00000000h, Unused				1Ch
Base Address Register 4: R/O 00000000h, Unused				20h
Base Address Register 5: R/O 00000000h, Unused				24h
Cardbus CIS Pointer: R/O 00000000h, Unused				28h
Subsystem ID R/O 0000h if EXTEE not present, otherwise R/W, loaded from EEPROM		Subsystem Vendor ID R/O 0000h if EXTEE not present, otherwise R/W, loaded from EEPROM		2Ch
Expansion ROM Base Address: R/O 00000000h, Unused				30h
Reserved: R/O 00000000h				34h
Reserved: R/O 00000000h				38h
Max_Lat: R/O 18h 24 x 0.25uS = 6 uS	Min_Gnt: R/O 04h 4 x 0.25uS = 1uS	Interrupt Pin: R/O 01h, INTA used	Interrupt Line: R/W, default 0	3Ch
PMC Bit 15: PME# from D3cold: R/O 0 Bit 14: PME# from D3hot: R/O 1 Bit 13: PME# from D2: R/O 1 Bit 12: PME# from D1: R/O 1 Bit 11: PME# from D0: R/O 1 Bit 10: D2 support: R/O 1 Bit 9: D1 support: R/O 1 Bit 8-6: Reserved: R/O 000 Bit 5: Device Specific init: R/O 1 Bit 4: Auxiliary power: R/O 0 Bit 3: PME# clock: R/O 1 Bit 2-0: Version: R/O 001		Next Item Pointer: R/O 0h	Capability ID: R/O 1h	40h
Data: R/O 0	PMCSR_BSE: R/O 0	PMCSR Bit 15: PME# status: R/W 0 Bit 14-13: Data scale: R/O 00 Bit 12-9: Data select: R/O 0000 Bit 8: PME_En: R/W 0 Bit 7-2: Reserved: R/O 000000 Bit 1-0: Power state: R/W 00		44h

Table 2. PCI Configuration Space (cont.)

Subsystem Vendor ID Fields

The Subsystem ID and Subsystem Vendor ID fields in the PCI Configuration Space default to value 0000h unless an external EEPROM device is detected or unless the host has written to the appropriate internal register to program the values.

Interrupt Signal

The CS4622/24 PCI Interface includes an interrupt controller function which receives interrupt requests from multiple sources within the CS4622/24 device, and presents a single interrupt line (INTA) to the host system. Interrupt control registers in the CS4622/24 provide the host interrupt service routine with the ability to identify the source of the interrupt and to clear the interrupt sources. In the CS4622/24, the single external interrupt is expanded by the use of “virtual channels”. Each data stream which is read from or written to a modular buffer is assigned a virtual channel number. This virtual channel number is signalled by the DMA subsystem anytime the associated modulo buffer pointer passes the mid-point or wraps around. Virtual channels are also used for message passing between the CS4622/24 and the host.

SERIAL PORT CONFIGURATIONS

A flexible serial audio interface is provided which allows connection to external Analog-to-Digital Converters (ADCs), Digital-to-Analog Converters (DACs) or Codecs (combined ADC and DAC functions) in several different configurations. The serial audio interface includes a primary input/output port with dedicated serial data pins (SDIN, SDOUT), two auxiliary audio output ports (SDO2, SDO3) which share pins with the joystick interface button input functions, and one auxiliary audio input port (SDIN2). Each of these digital audio input and output pins carry two channels of audio data. These two channels may comprise the left and right channels of a stereo audio signal, or two independent monaural audio signals.

Each digital audio channel is internally buffered through a 16 sample x 20-bit FIFO. The data format for the serial digital audio ports varies depending on the configuration. The primary configuration includes a CS4622/24 plus a CS4297. In addition, a dual AC '97 interface is supported where the second CS4297 is used as a modem front end or for docking station support.

The CS4622/24 communicates with the CS4297 over the AC-link as specified in the Intel® Audio Codec '97 Specification (version 1.03) with support for the 2.0 extensions. A block diagram for the AC'97 Controller configuration is given in Figure 8. The signal connections between the CS4622/24 and the AC '97 Codec are indicated in Figure 12. In this configuration, the AC '97 Codec is the timing master for the digital audio link. The ASDOUT output supports data transmission on all ten possible sample slots (output slots 3 - 12). The ASDIN input supports receiving of audio sample data on all input sample slots (input slots 3 - 12). The SDO2 and SDO3 serial outputs and the SDIN2 serial input are not supported in this configuration.

In the dual AC '97 system, the primary AC '97 codec is connected as in the single codec case; however, a second CS4297 is connected to a completely separate and independent AC-Link. Both AC '97 codecs must use the same master clock. A block diagram depicting the Dual AC'97 Controller configuration as a docking station is given in Figure 9. In this scenario, the first codec is used in the portable for traditional functions such as analog support for the portable's Line In, Mic In, and Line Out jacks. The second AC Link is buffered (along with the master clock) and sent across to the docking station to support a second CS4297 that supports the dock's analog jacks. When the system gets a message that the docking station is attached, the software can replace the portable's analog jack control for the docking station's jacks seamlessly. Using a standard AC Link for the docking station support maintains the highest quality of

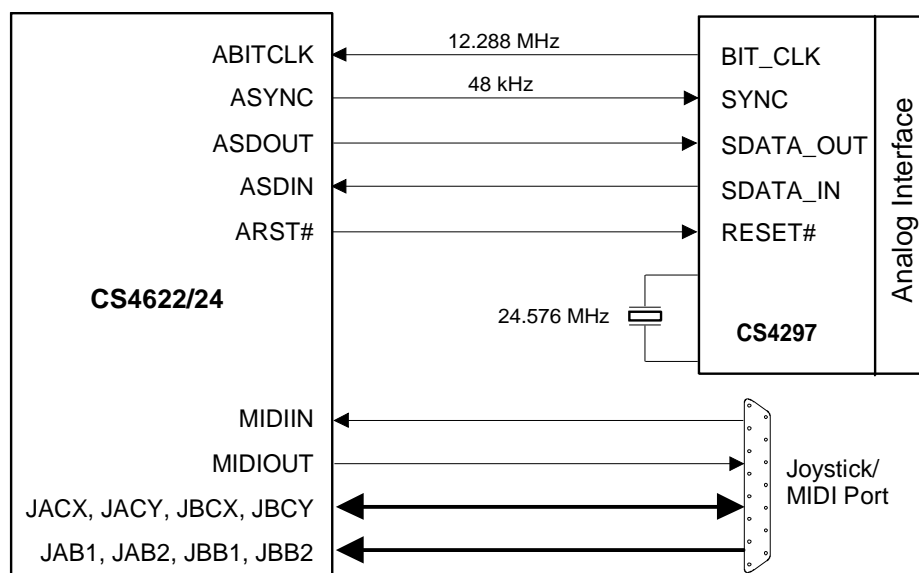

Figure 12. AC '97 Codec Connection Diagram

audio over analog docking station scenarios. In addition, since the AC Link is a standard, the docking station can be utilized over a number of portable generations without concern for obsolescence.

A block diagram depicting the Dual AC'97 Controller configuration as a modem analog front end is illustrated in Figure 10. In this scenario, the primary AC 97 codec is used for the traditional support of analog I/O. The second CS4297 is utilized as the analog front end connected to the analog DAA interface. The digital DAA control is supported through the extended general purpose I/O (EGPIO) pins on the CS4622/24.

The signal connections between the CS4622/24 and the dual Codecs are shown in Figure 13. In this configuration, both AC '97 codecs must run off the same master clock with the primary AC '97 Codec being the timing master for the first AC Link and for the CS4622/24. The secondary CS4297 is timing master for the second AC-Link. Full FIFO buffers for both links are supported.

MIDI Port

In the AC '97 controller configuration, a bi-directional MIDI interface is provided to allow connec-

tion of external MIDI devices. The MIDI interface includes 16-byte FIFOs for the MIDI transmit and receive paths.

Joystick Port

In the AC '97 controller configuration, a joystick port is provided. The joystick port supports four "coordinate" channels and four "button" channels. The coordinate channels provide joystick positional information to the host, and the button channels provide user button event information. The joystick interface is capable of operating in the traditional "polled" mode, but also provides a "hardware accelerated" mode of operation wherein internal counters are provided to assist the host with coordinate position determination. The Joystick schematic is illustrated in Figure 14.

EEPROM INTERFACE

The EEPROM configuration interface allows the connection of an optional external EEPROM device to provide power-up configuration information. The external EEPROM is not required for proper operation; however, in some applications power-up configuration settings other than the de-

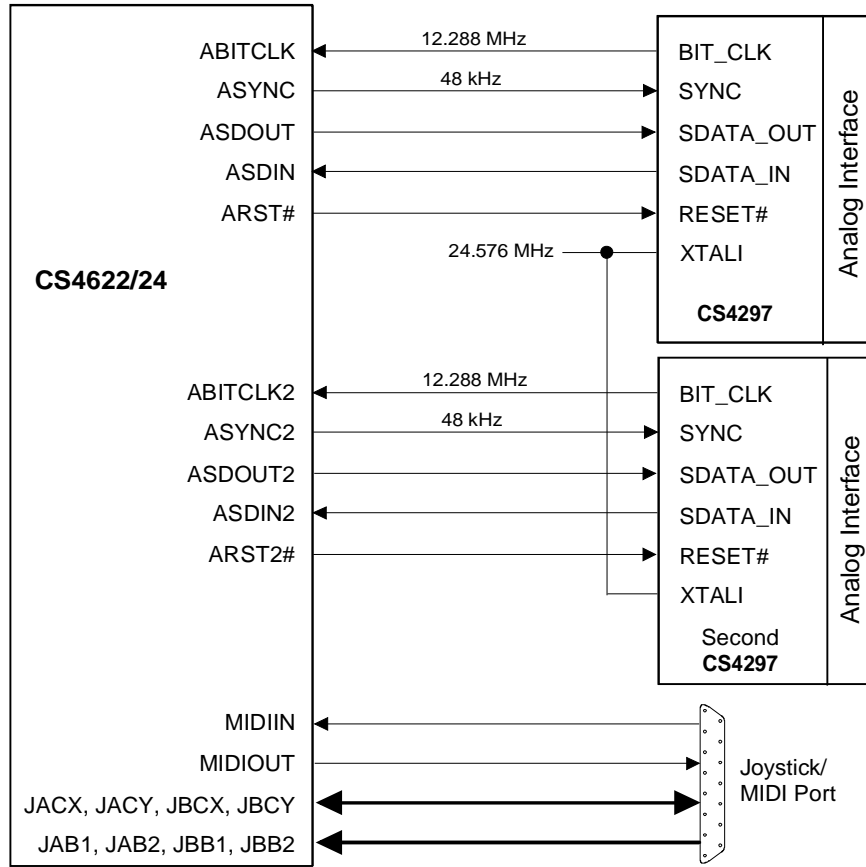

Figure 13. Dual AC '97 Codec Connection Diagram

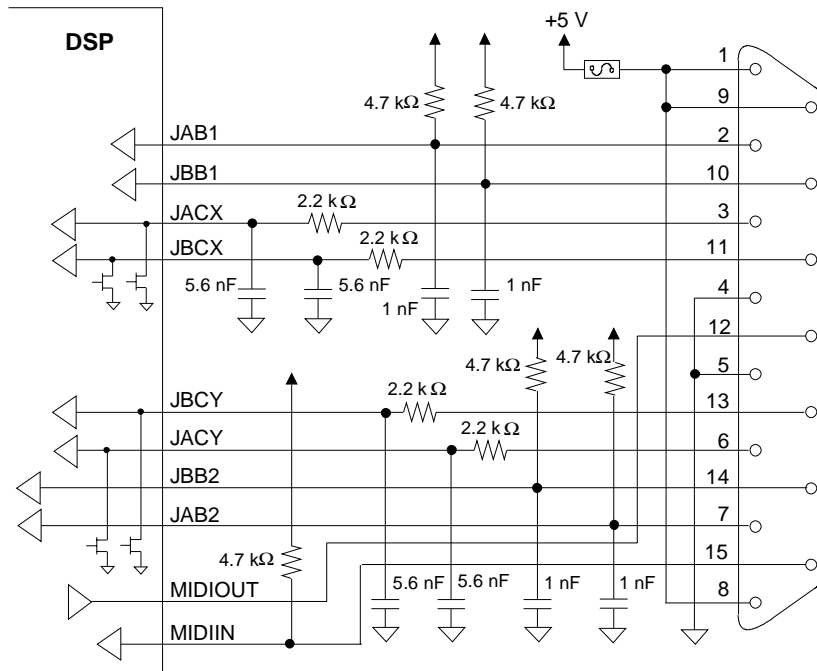

Figure 14. Joystick Logic

fault values may be required to support specific Operating System compatibility requirements.

After a hardware reset, an internal state machine in the CS4622/24 will automatically detect the presence of an external EEPROM device (assuming EEPDIS is low) and load the Subsystem ID and Subsystem Vendor ID fields, along with two bytes of general configuration information, into internal registers. At power-up, the CS4622/24 will attempt to read from the external device, and will check the data received from the device for a valid signature header. If the header data is invalid, the data transfer is aborted. After power-up, the host can read or write from/to the EEPROM device by accessing specific registers in the CS4622/24. Cirrus Logic provides software to read and write the EEPROM.

The two-wire interface for the optional external EEPROM device is depicted in Figure 15. During data transfers, the data line (EEDAT) can change state only while the clock signal (EECLK) is low. A state change of the data line while the clock signal is high indicates a start or stop condition to the EEPROM device.

The EEPROM device read access sequence is shown in the Figure 16. The timing follows that of a random read sequence. The CS4622/24 first performs a “dummy” write operation, then generates a start condition followed by the slave device address and the byte address of zero. The CS4622/24 always begins access at byte address zero and continues access a byte at a time, using a

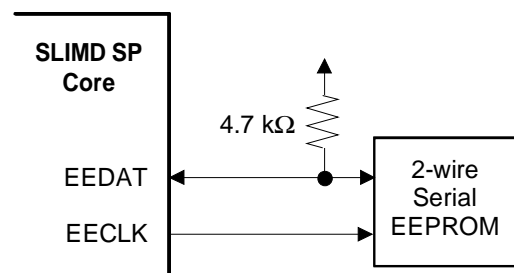

Figure 15. External EEPROM Connection

sequential read, until all needed bytes in the EEPROM are read. Since only 7 bytes are needed, the smallest EEPROM available will suffice.

GENERAL PURPOSE I/O PINS

Many of the CS4622/24 signal pins are internally multiplexed to serve different functions depending on the environment in which the device is being used. Several of the CS4622/24 signal pins may be used as general purpose I/O pins when not required for other specific functions in a given application.

ZV PORT SERIAL INTERFACE

The ZV PORT interface consists of three input pins: ZLRCK, ZSCLK, and ZSDATA. ZLRCK is the Left/Right clock indicating which channel is currently being received. ZSCLK is the serial bit clock where ZLRCK and ZSDATA change on the falling edge and serial data is internally latched on the rising edge. Note that the serial data starts one ZSCLK period after ZLRCK transitions. Figure 17 illustrates the clocking on the ZV PORT pins. ZV PORT is available only in the CS4280-CQ.

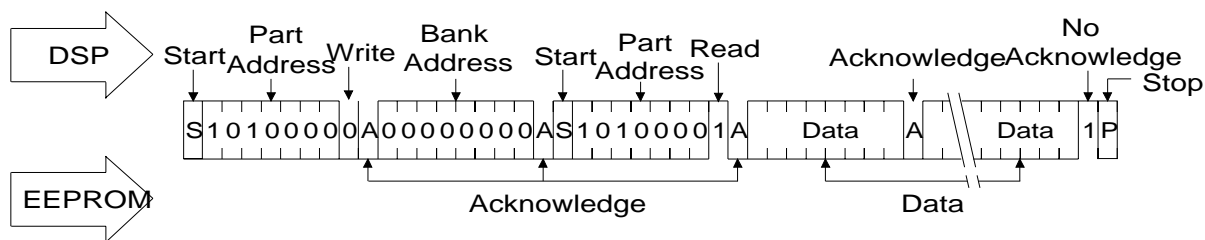

Figure 16. EEPROM Read Sequence

CONSUMER IEC-958 DIGITAL INTERFACE (S/PDIF)

The CS4622/24 supports the industry standard IEC-958 consumer digital interface. Sometimes this standard is referred to as S/PDIF, which refers to an older version of this standard. This output provides an interface, external to the PC, for storing digital audio (as in a DAT or recordable CD-ROM) or playing digital audio from digital speakers.

Figure 18 illustrates the circuit necessary for implementation of the IEC-958 consumer interface.

An external buffer is required to drive the current needed to drive the 75 Ω interface. A current driver is implemented to increase the transmission range of the coaxial circuitry.

Figure 19 illustrates an optional fiber optic circuit. The optical circuit connects directly to the CS4622/24 and no additional current driver is needed.

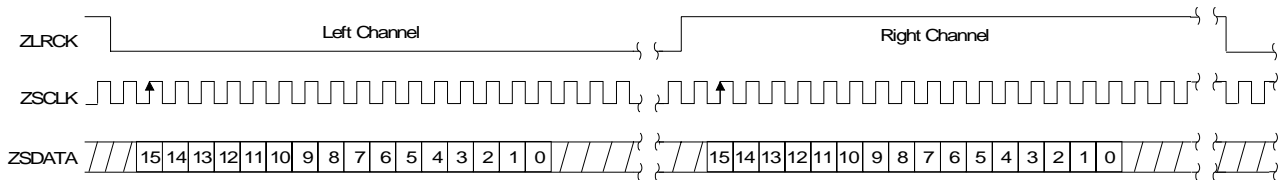

Figure 17. ZV Port Clocking Format

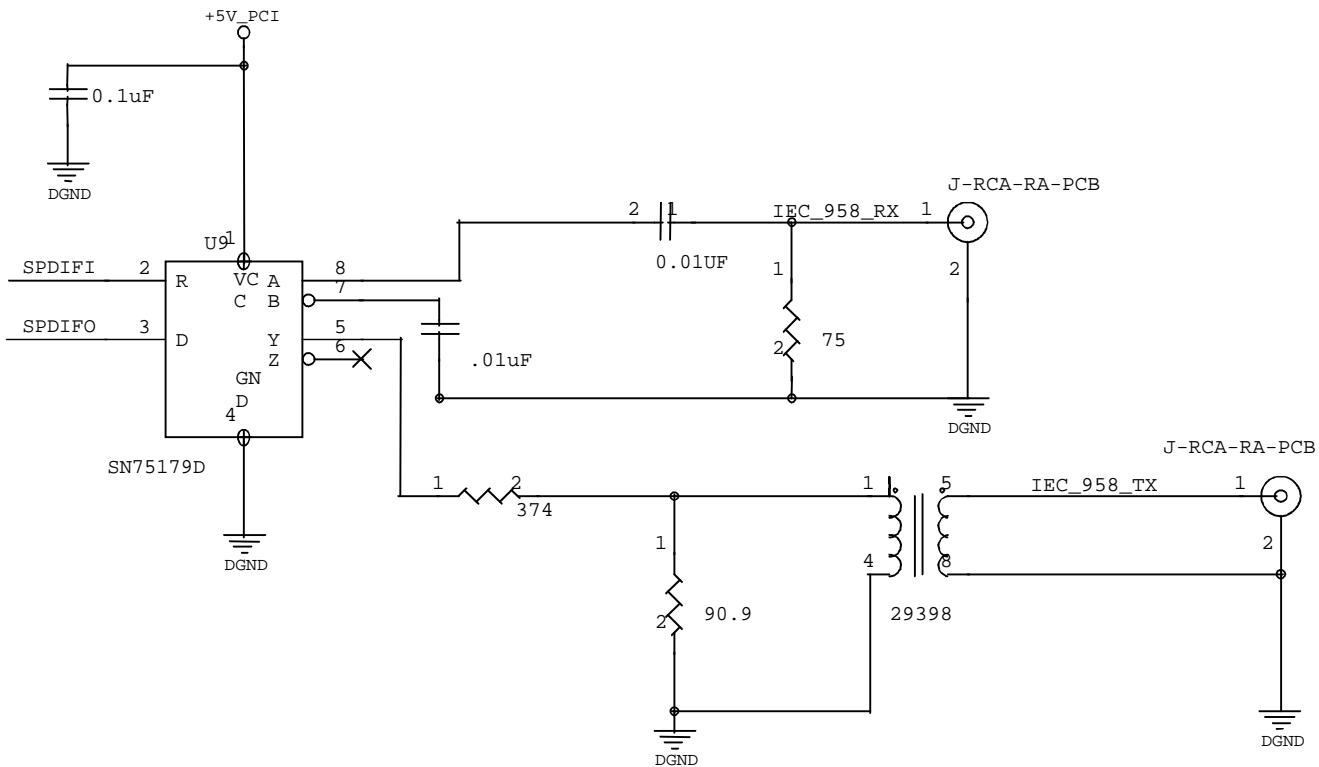

Figure 18. IEC Consumer Interface Implementation Circuit

EGPIO

In addition to the GPIO pins on the CS4622/24, extended general purpose I/O has been added. Five EGPIO pins are not multiplexed, EGPIO[8:7, 2:0]; whereas; EGPIO[6:3] are shared with the asynchronous serial port. When this second async. serial port is not used, all the EGPIO pins are available. These pins have extended functionality in that any EGPIO pin can be programmed to cause a power

management wake-up event on the PME# signal. This feature enables an incoming call on a modem to wake-up a powered-down system without user intervention. These pins also can be programmed as:

- input or output,
- edge or level sensitive (sticky),
- active high or low input,
- CMOS or open-drain output

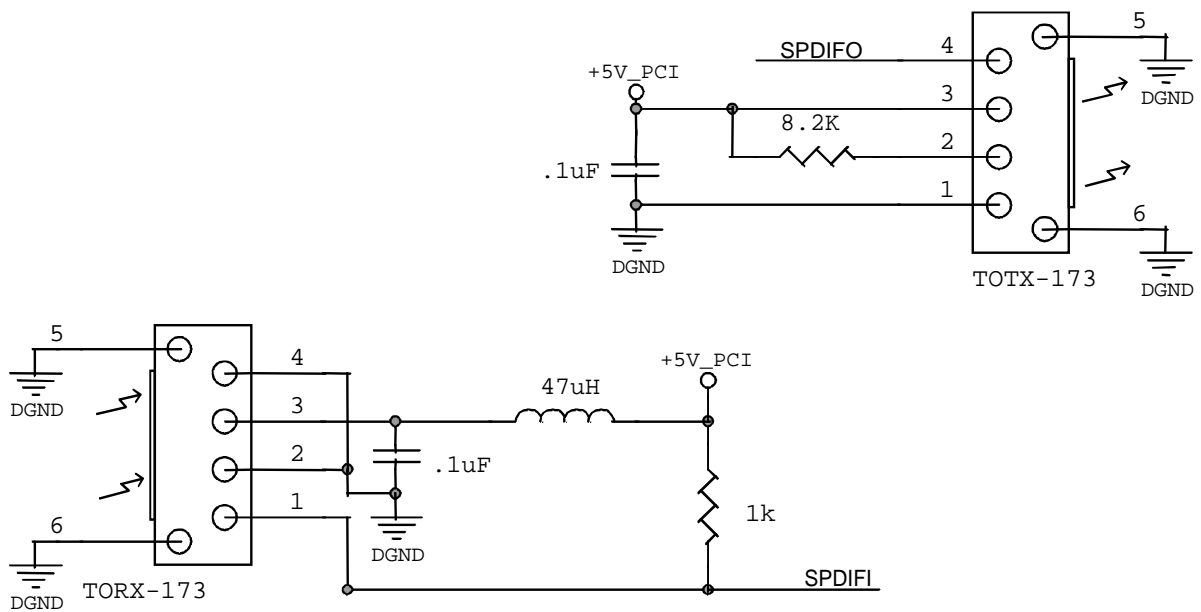

Figure 19. Optional Fiber Optic Circuit

PIN DESCRIPTION

	CLKRUN#	EGPIO[7]	ARST2#	ASYNC2	ASDOUT2	ABITCLK2	PCIVDD[7]	PCIGND[7]	AD[0]	AD[1]	AD[2]	AD[3]	AD[4]	AD[5]	AD[6]	AD[7]	PCIGND[6]	PCIVDD[6]	C/BE[0]#	AD[8]	AD[9]	AD[10]	AD[11]	AD[12]	AD[13]	PCIVDD[5]			
TEST	65	64	63	62	61	60	59	58	57	56	55	54	53	52	51	50	49	48	47	46	45	44	43	42	41	40	39	38	PCIGND[5]
JACX	66																										37	AD[14]	
JACY	67																										36	AD[15]	
JBCX	68																										35	C/BE[1]#	
JBCY	69																										34	PAR	
JAB1/SDO2	70																										33	SERR#	
JAB2/SDO3	71																										32	PERR#	
JBB1/LRCLK	72																										31	STOP#	
JBB2/MCLK	73																										30	PCIGND[4]	
MIDIIN	74																										29	PCIVDD[4]	
CVDD[2]	75																										28	DEVSEL#	
CGND[2]	76																										27	CVDD[0]	
MIDIOUT	77																										26	CGND[0]	
CVDD[3]	78																										25	TRDY#	
CGND[3]	79																										24	IRDY#	
ZLRCLK	80																										23	EEPDS	
ZSCLK	81																										22		
ZSDATA	82																										21		
SPDIFI	83																										20		
SPDIFO	84																										19		
EGPIO[0]	85																										18		
EGPIO[1]	86																										17		
EGPIO[2]	87																										16		
SDIN2/GPIO	88																										15	FRAME#	
CGND[4]	89																										14	C/BE[2]#	
CVDD[4]	90																										13	CGND[1]	
CRYVDD	91																										12	CVDD[1]	
VOLUP/XTALI	92																										11	AD[16]	
VOLDN/XTALO	93																										10	AD[17]	
CRYGND	94																										9	AD[18]	
VDD5REF	95																										8	PCIVDD[3]	
ABITCLK/SCLK	96																										7	PCIGND[3]	
ASDOUT/SDOUT	97																										6	AD[19]	
ASDIN/SDIN	98																										5	AD[20]	
ASYNC/FSYNC	99																										4	AD[21]	
ARST#	100																										3	AD[22]	
EECLK/PCREQ#	101																										2	AD[23]	
EEDAT/PCGNT#	102	103	104	105	106	107	108	109	110	111	112	113	114	115	116	117	118	119	120	121	122	123	124	125	126	127	128	1	PCIGND[2]
		EGPIO[3]/ASCLK	EGPIO[4]/ASFCLK	EGPIO[5]/ASDI	EGPIO[6]/ASDO	ASDIN2	PME#	INTA#	RST#	PCICLK	GNT#	REQ#	PCIVDD[0]	PCIGND[0]	AD[31]	AD[30]	AD[29]	AD[28]	AD[27]	PCIGND[1]	PCIVDD[1]	AD[26]	AD[25]	AD[24]	C/BE[3]#	IDSEL	PCIVDD[2]		

128-pin TQFP



A '#' sign suffix on a pin names indicates an active-low signal.

PCI Interface

AD[31:0] - Address/Data Bus, I/O, Pins 116-120, 123-125, 2-6, 9-11, 36-37, 40-45, 49-56

These pins form the multiplexed address / data bus for the PCI interface.

C/BE[3:0]# - Command Type / Byte Enables, I/O, Pins 126, 14, 35, 46

These four pins are the multiplexed command / byte enables for the PCI interface. During the address phase of a transaction, these pins indicate cycle type. During the data phases of a transaction, active low byte enable information for the current data phase is indicated. These pins are inputs during slave operation and they are outputs during bus mastering operation.

PAR - Parity, I/O, Pin 34

The Parity pin indicates even parity across AD[31:0] and C_BE[3:0] for both address and data phases. The signal is delayed one PCI clock from either the address or data phase for which parity is generated.

FRAME# - Cycle Frame, I/O, Pin 15

FRAME# is driven by the current PCI bus master to indicate the beginning and duration of a transaction.

IRDY# - Initiator Ready, I/O, Pin 24

IRDY# is driven by the current PCI bus master to indicate that as the initiator it is ready to transmit or receive data (complete the current data phase).

TRDY# - Target Ready, I/O, Pin 25

TRDY# is driven by the current PCI bus target to indicate that as the target device it is ready to transmit or receive data (complete the current data phase).

STOP# - Transition Stop, I/O, Pin 31

STOP# is driven active by the current PCI bus target to indicate a request to the master to stop the current transaction.

IDSEL - Initialize Device Select, Input, Pin 127

IDSEL is used as a chip select during PCI configuration read and write cycles.

DEVSEL# - Device Select, I/O, Pin 28

DEVSEL# is driven by the PCI bus target device to indicate that it has decoded the address of the current transaction as its own chip select range.

REQ# - Master Request, Three-State Output, Pin 113

REQ# indicates to the system arbiter that this device is requesting access to the PCI bus. This pin is high-impedance when RST# is active.

GNT# - Master Grant, Input, Pin 112

GNT# is driven by the system arbiter to indicate to the device that the PCI bus has been granted.

PERR# - Parity Error, I/O, Pin 32

PERR# is used for reporting data parity errors on the PCI bus.

SERR# - System Error, Open Drain Output, Pin 33

SERR# is used for reporting address parity errors and other catastrophic system errors.

INTA# - Host Interrupt A (for SP), Open Drain Output, Pin 109

INTA# is the level triggered interrupt pin dedicated to servicing internal device interrupt sources.

PCICLK - PCI Bus Clock, Input, Pin 111

PCICLK is the PCI bus clock for timing all PCI transactions. All PCI synchronous signals are generated and sampled relative to the rising edge of this clock.

RST# - PCI Device Reset, Pin 110

RST# is the PCI bus master reset.

VDD5REF: Clean 5 V Power Supply, Pin 95

VDD5REF is the power connection pin for the 5 V PCI pseudo supply for the PCI bus drivers. The internal core logic runs on 3.3 Volts. This pin enables the PCI interface to support and be tolerant of 5 Volt signals. Must be connected to +5 Volts.

PCIVDD[7:0] - PCI Bus Driver Power Supply, Pins 58, 47, 39, 29, 8, 128, 122, 114

PCIVDD pins are the PCI driver power supply pins. These pins must have a nominal +3.3 Volts.

PCIGND[7:0] - PCI Bus Driver Ground Pins, Pins 57, 48, 38, 30, 7, 1, 121, 115

PCIGND pins are the PCI driver ground reference pins.

PME# - PCI Power Management Event, Open Drain Output, Pin 108

PME# signals a power management event. This signal can go low because of an AC '97 2.0 Codec, an event on a EGPIO[8:0] bit, or host software.

External Interface Pins

TEST - Test Mode Strap, Input, Pin 65

This pin is sampled at reset for test mode entry. If it is high at reset, test mode is enabled. This pin must be pulled to ground for normal operation.

EEDAT/PCGNT# - EEPROM Data Line / PC/PCI Grant, I/O, Pin 102

For expansion card designs, this is the data line for external serial EEPROM containing device configuration data. When used with an external EEPROM (EEPDIS must be low), a 4.7 k Ω pullup resistor is required. In motherboard designs using PC/PCI, this pin is the PC/PCI serialized grant input. In designs with neither of the above requirements, this pin can be used as a general purpose input or open drain output (GPIO2).

EECLK/PCREQ# - EEPROM Clock Line / PC/PCI Request, Output, Pin 101

For expansion card designs, this is the clock line for external serial EEPROM containing device configuration data (EEPDIS must be low). In motherboard designs using PC/PCI, this pin is the PC/PCI serialized request output. In designs with neither of the above requirements, this pin can be used as a general purpose output pin (GPOUT).

EEPDIS - EEPROM Disable, Input, Pin 23

This strapping pin, when tied high, disables the EEPROM interface. When low, the CS4622/24 checks at power-up for an external EEPROM on the EECLK and EEDAT pins.

SDIN2/GPIO - Serial Data Input 2 / General Purpose I/O Pin, I/O, Pin 88

This dual function pin defaults as a general purpose I/O pin. In non-AC '97 system configurations, this pin can function as a second stereo digital data input pin if enabled.

VOLUP/XTALI - Volume-Up Button / Crystal In, Input, Pin 92

This dual function pin is either the volume-up button control input or the crystal oscillator input pin, depending on system configuration. This pin may also be used as a general purpose input if its primary function is not needed.

VOLDN/XTALO - Volume-Down Button / Crystal Output, I/O, Pin 93

This dual function pin is either the volume-down button control input or the crystal oscillator output pin, depending on system configuration. This pin may also be used as a general purpose input if its primary function is not needed.

Clock / Miscellaneous**CLKRUN# - Optional System Clock Control, Pin 64**

CLKRUN# is an optional PCI signal defined for mobile operations. This is an open drain output signalling the system that the PCI clock is required. This signal pin is not available on the add-in card connector.

CRYVDD - Crystal & PLL Power Supply, Pin 91

Power pin for crystal oscillator and internal phase locked loop. This pin must be connected to a nominal +3.3 Volts.

CRYGND - Crystal & PLL Ground Supply, Pin 94

Ground pin for crystal oscillator and internal phase locked loop.

JACX, JACY, JBCX, JBCY - Joystick A and B X/Y Coordinates, I/O, Pins 66, 67, 68, 69

These pins are the 4 axis coordinates for the joystick port. These pins may also be used as a general purpose inputs or open drain outputs if their primary function is not needed.

JAB1/SDO2 - Joystick A Button 1 / Serial Data Output 2, I/O, Pin 70

This dual function pin defaults as JAB1 (button 1 input for joystick A). In non-AC '97 system configurations, this pin can function as a second stereo digital data output pin if enabled. This pin can also be a general purpose polled input if a second data output stream is not required.

JAB2/SDO3 - Joystick A Button 2 / Serial Data Output 3, I/O, Pin 71

This dual function pin defaults as JAB2 (button 2 input for joystick A). In non-AC '97 system configurations, this pin can function as a third stereo digital data output pin if enabled. This pin can also be a general purpose polled input if a third data output stream is not required.

JBB1/LRCLK - Joystick B Button 1 / L/R Framing Clock, I/O, Pin 72

This dual function pin defaults as JBB1 (button 1 input for joystick B). In non-AC '97 system configurations, this pin can function as a left/right framing clock output pin for SDO2 and SDO3. This pin can also be used as a general purpose polled input if alternate data output streams are not required.

JBB2/MCLK - Joystick B Button 2 / Master Clock, I/O, Pin 73

This dual function pin defaults as JBB2 (button 2 input for joystick B). In non-AC '97 system configurations, this pin can function as a master (256x sample rate) output clock if enabled. This pin can also be used as a general purpose polled input if alternate data output streams are not required.

MIDIIN - MIDI Data Input, Pin 74

This is the serial input pin for the internal MIDI port.

MIDIOUT - MIDI Data Output, Pin 77

This is the serial output pin for the internal MIDI port.

CVDD[4:0] - Core Power Supply, Pins 90, 78, 75, 12, 27

Core / Stream Processor power pins. These pins must be connected to a nominal +3.3 Volts.

CGND[4:0] - Core Ground Supply, Pins 89, 79, 76, 13, 26

Core / Stream Processor ground reference pins.

Serial Codec Interface

ABITCLK/SCLK - Primary AC '97 Bit Clock / Serial Audio Data Clock, I/O, Pin 96

Master timing clock for serial audio data. In AC '97 configurations, this pin is an input which drives the timing for the AC '97 interface, along with providing the source clock for the CS4622/24. In external DAC configurations, it an output, providing the serial bit clock.

ASYNC/FSYNC - Primary AC '97 Frame Sync / Serial Audio Frame Sync, I/O, Pin 99

Framing clock for serial audio data. In AC '97 configurations, this pin is an output which indicates the framing for the AC '97 link. In external DAC configurations, this pin is an FSYNC output, providing the left/right framing clock.

ASDOUT/SDOUT - Primary AC '97 Data Out / Serial Audio Data Out, Output, Pin 97

AC '97 serial data out / Serial audio output data.

ARST# - Primary AC '97 Reset, Output, Pin 100

AC '97 link reset pin. This pin also functions as a general purpose reset output in non-AC '97 configurations and will follow RST# to ground, but must be forced high by software.

ASDIN/SDIN - Primary AC '97 Data In / Serial Audio Data In, Input, Pin 98

Serial audio input data.

ASDIN2 - Second AC '97 Data In, Pin 107

AC '97 (2.0) Serial audio input data for the second AC '97 Codec. The other AC link pins are either shared with the first AC '97 interface or connected to the second complete AC '97 interface listed below.

ABITCLK2 - Second AC '97 Link Bit Clock, Input, Pin 59

Master timing clock for the second AC '97 serial link.

ASYNC2 - Second AC '97 Link Frame Sync, Output, Pin 61

Framing clock for second AC '97 link serial audio data. This pin is an output which indicates the framing for the second AC '97 link.

ASDOUT2 - Second AC '97 Link Data Out, Output, Pin 60

AC '97 serial data out / Serial audio output data.

ARST2# - Second AC '97 Link Reset, Output, Pin 62

Second AC '97 link reset pin. This pin also functions as a general purpose reset output in non-AC '97 configurations and will follow RST# pin 82 to ground, but must be forced high by software.

ZV Port Serial Interface**ZSCLK - ZV Port Serial Clock, Input, Pin 81**

ZV Port serial bit clock.

ZLRCLK - ZV Port Left/Right Clock, Input, Pin 80

ZV Port left/right channel delineation.

ZSDATA - ZV Port Serial Data In, Input, Pin 82

ZV Port serial data input pin.

Consumer Digital Audio I/O (S/PDIF)**SPDIFO - Consumer Digital Audio Out, Output, Pin 84**

This CMOS pin outputs serial data that conforms to the IEC-958 consumer format. The data is bi-phase mark encoded and requires external drivers.

SPDIFI - Consumer Digital Audio In, Input, Pin 83

This pin receives asynchronous serial data that conforms to the IEC-958 consumer format. The data should be bi-phase mark encoded.

Asynchronous Serial Interface and Enhanced General Purpose I/O**ASCLK/EGPIO[3] - Async. Serial Port Clock / Enhanced Gen. Purpose I/O, I/O, Pin 103**

Serial Clock that controls the asynchronous serial interface. As ASCLK, this pin can be either an async. input bit clock or, when the AC '97 interface is enabled, can be an output programmed for a frequency of ABITCLK/4. When not used as an async. port bit clock, this pin is enhanced general purpose I/O bit 3 (see EGPIO[8:7, 2:0] for more details.)

ASFCLK/EGPIO[4] - Async. Serial Frame Clock / Enhanced Gen. Purpose I/O, I/O, Pin 104

Serial Frame signal that delineates left from right data. As ASFLCK, this pin can be either an input L/R framing clock that must be synchronous to ASCLK, or when the AC '97 interface is enabled, an output fixed at ASCLK/64. When not used as an async. port framing signal, this pin is enhanced general purpose I/O bit 4 (see EGPIO[8:7, 2:0] for more details.)

ASDI/EGPIO[5] - Async. Serial Port Data In / Enhanced Gen. Purpose I/O, I/O, Pin 105

When used as ASDI, stereo data is clocked into the CS4622/24 with ASCLK with ASFCLK delineating left from right. Otherwise, this pin is enhanced general purpose I/O bit 5 (see EGPIO[8:7, 2:0] for more details.)

ASDO/EGPIO[6] - Async. Serial Port Data Out / Enhanced Gen. Purpose I/O, I/O, Pin 106

When used as ASDO, stereo data is clocked out of the CS4622/24 using ASCLK with ASFCLK delineating left from right. Otherwise, this pin is enhanced general purpose I/O bit 6 (see EGPIO[8:7, 2:0] for more details.)

EGPIO[7, 2:0] - Extended General Purpose I/O Bits, I/O, Pins 63, 87, 86, 85

These bits along with bits EGPIO[6:3] have extended programmability and can be used for any application such as modem DAA control. Programmability features include: direction, polarity, level/edge sensitive, and the ability to set PME# active for a power management wake-up event.

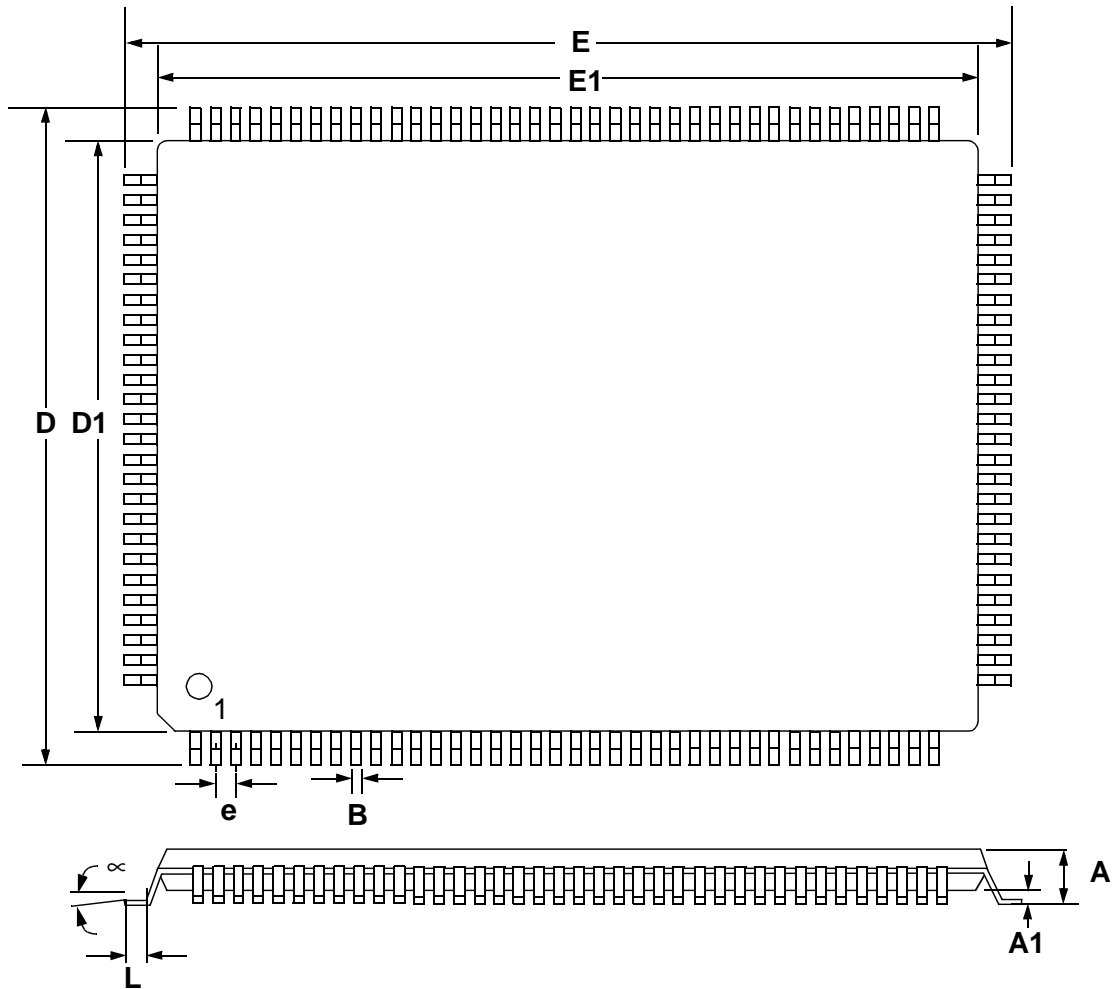
PACKAGE OUTLINE
'Q' Package 128-pin TQFP

DIM	INCHES			MILLIMETERS		
	MIN	NOM	MAX	MIN	NOM	MAX
A	0.000		0.063	0.000		1.600
A1	0.002		0.006	0.050		0.150
B	0.007		0.011	0.170		0.270
D	0.626		0.634	15.900	14.000	16.100
D1	0.547		0.555	13.900		14.100
E	0.862		0.870	21.900		22.100
E1	0.783		0.791	19.900	20.000	20.100
e	0.016		0.024	0.400	0.500	0.600
∞	0.000		7.000	0.000		7.000
L	0.018		0.030	0.450		0.750

• Notes •

SMART
Analog™