

## General Description

The AAT3685 BatteryManager™ is a highly integrated single cell lithium-ion/polymer battery charger IC designed to operate with USB port or line adapter inputs. It requires the minimum number of external components.

The AAT3685 precisely regulates battery charge voltage and current for 4.2V lithium-ion/polymer battery cells. Regardless of the type of input power source (USB or adapter), the AAT3685 can be programmed for two separate constant current charge levels up to 1A. An optional Charge Reduction Loop is built in to allow users to charge the battery with available current from the charge supply, while keeping the port voltage regulated.

Battery temperature and charge state are fully monitored for fault conditions. In the event of an over-voltage or over-temperature failure, the device will automatically shut down, thus protecting the charging device, control system, and the battery under charge. Status monitor output pins are provided to indicate the battery charge status by directly driving two external LEDs. A serial interface output is available to report any one of 14 various status states to a microcontroller.

The AAT3685 is available in a Pb-free, thermally-enhanced, space-saving 12-pin 3x3mm TDFN package and is rated over the -40°C to +85°C temperature range.

## Features

- Adapter or USB Charger
  - Programmable up to 1A Max
- 4.0V to 5.5V Input Voltage Range
- High Level of Integration With Internal:
  - Charging Device
  - Reverse Blocking Diode
  - Current Sensing
- Automatic Recharge Sequencing
- Charge Reduction Loop
- Battery Temperature Monitoring
- Full Battery Charge Auto Turn-Off
- Over-Voltage Protection
- Emergency Thermal Protection
- Power On Reset and Soft Start
- Serial Interface Status Reporting
- 12-Pin 3x3mm TDFN Package

## Applications

- Cellular Telephones
- Digital Still Cameras
- Hand-Held PCs
- MP3 Players
- Personal Data Assistants (PDAs)
- Other Lithium-Ion/Polymer Battery-Powered Devices

## Typical Application

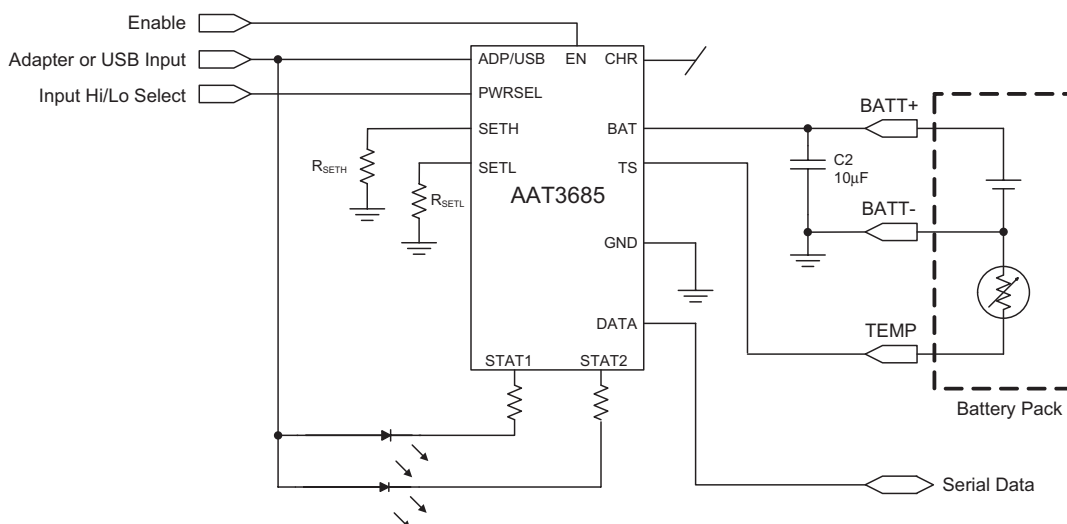

### Pin Descriptions

Pin #	Name	Type	Function
1	ADP/USB	In	Line adapter or USB power supply input.
2	BAT	In/Out	Battery charging and sensing.
3	GND	Ground	Ground connection.
4	CHR	In/Out	Resistor divider to set USB voltage regulation for charge reduction mode. Leave this pin open for default 4.5V USB regulation point. Tie to ADP/USB pin to disable this function.
5	EN	In	Enable pin. Logic high enables the IC.
6	TS	In/Out	Connect to 10kΩ NTC thermistor.
7	DATA	In/Out	Status report to microcontroller via serial interface, open-drain.
8	STAT2	Out	Battery charge status indicator pin to drive an LED: active low, open-drain.
9	STAT1	Out	Battery charge status indicator pin to drive an LED: active low, open-drain.
10	PWRSEL	In	When ADP/USB is present, use this pin to toggle between SETH and SETL charging levels.
11	SETL	In/Out	Connect resistor here to set charge current for low-current port.
12	SETH	In/Out	Connect resistor here to set charge current for high-current port.
EP			Exposed paddle (bottom); connect to GND directly beneath package.

### Pin Configuration

**TDFN33-12  
(Top View)**

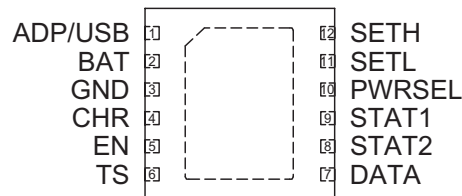

### AAT3685 Feature Options

Product	Internal Pull-Up Resistor on EN Pin	Can Leave TS Pin Open
AAT3685	No	No
AAT3685-1	Yes	Yes

### Absolute Maximum Ratings<sup>1</sup>

Symbol	Description	Value	Units
$V_P$	ADP/USB Input Voltage, <30ms, Duty Cycle <10%	-0.3 to 7.0	V
$V_P$	ADP/USB Input Voltage, Continuous	-0.3 to 6.0	V
$V_N$	BAT, PWRSEL, SETH, SETL, STAT1, STAT2, DATA, TS, CHR, EN	-0.3 to $V_P + 0.3$	V
$T_J$	Operating Junction Temperature Range	-40 to 150	°C
$T_{LEAD}$	Maximum Soldering Temperature (at leads)	300	°C

### Thermal Information<sup>2</sup>

Symbol	Description	Value	Units
$\theta_{JA}$	Maximum Thermal Resistance (3x3mm TDFN)	50	°C/W
$P_D$	Maximum Power Dissipation	2.0	W

1. Stresses above those listed in Absolute Maximum Ratings may cause permanent damage to the device. Functional operation at conditions other than the operating conditions specified is not implied. Only one Absolute Maximum Rating should be applied at any one time.  
 2. Mounted on an FR4 board.

### Electrical Characteristics<sup>1</sup>

$V_{ADP} = 5V$ ,  $T_A = -25^{\circ}C$  to  $+85^{\circ}C$ , unless otherwise noted. Typical values are at  $T_A = 25^{\circ}C$ .

Symbol	Description	Conditions	Min	Typ	Max	Units
<b>Operation</b>						
ADP/USB	Input Voltage Range		4.0		5.5	V
$V_{UVLO}$	Under-Voltage Lockout	Rising Edge		3.0		V
	Under-Voltage Lockout Hysteresis			150		mV
$I_{OP}$	Operating Current	CC Charge Current = 500mA		0.75	1.5	mA
$I_{SLEEP}$	Sleep Mode Current	AAT3685: $V_{BAT} = 4.25V$		0.3	1.0	$\mu A$
		AAT3685-1: $V_{BAT} = 4.25V$		1	3	
$I_{Leakage}$	Reverse Leakage Current from BAT Pin	$V_{BAT} = 4V$ , ADP/USB Pin Open		1.0		$\mu A$
<b>Voltage Regulation</b>						
$V_{BAT\_EOC}^1$	End of Charge Voltage Accuracy		4.158	4.2	4.242	V
$\Delta V_{BAT}/V_{BAT}$	EOC Voltage Tolerance			0.5		%
$V_{MIN}$	Preconditioning Voltage Threshold		2.8	3.0	3.15	V
$V_{RCH}$	Battery Recharge Voltage Threshold			$V_{BAT\_EOC} - 0.1$		V
$V_{ADP/USB\_CHR}$	Charge Reduction Regulation	No Connection on CHR Pin	4.3	4.5	4.64	V
$V_{CHR}$	CHR Pin Voltage Accuracy		1.9	2.0	2.1	V
<b>Current Regulation</b>						
$I_{CH}$	Charge Current		50		1000	mA
$\Delta I_{CH}/I_{CH}$	Charge Current Regulation Tolerance			10		%
$V_{SETH}$	SETH Pin Voltage	CC Mode		2.0		V
$V_{SETL}$	SETL Pin Voltage	CC Mode		2.0		V
$K_{IUH}$	Current Set Factor: $I_{CHARGE}/I_{SETH}$			2000		
$K_{IUL}$	Current Set Factor: $I_{CHARGE}/I_{SETL}$			2000		
<b>Charging Devices</b>						
$R_{DS(ON)U}$	Charging MOSFET Transistor On Resistance	$V_{IN} = 5.5V$	0.4	0.5	0.65	$\Omega$

1. The AAT3685 output charge voltage is specified over the  $0^{\circ}$  to  $70^{\circ}C$  ambient temperature range; operation over the  $-25^{\circ}C$  to  $+85^{\circ}C$  temperature range is guaranteed by design.

### Electrical Characteristics<sup>1</sup>

$V_{ADP} = 5V$ ,  $T_A = -25^{\circ}C$  to  $+85^{\circ}C$ , unless otherwise noted. Typical values are at  $T_A = 25^{\circ}C$ .

Symbol	Description	Conditions	Min	Typ	Max	Units
<b>Logic Control / Protection</b>						
$V_{PWRSEL(H)}$	Input High Threshold		1.6			V
$V_{PWRSEL(L)}$	Input Low Threshold				0.4	V
$V_{EN(H)}$	Input High Threshold		1.6			V
$V_{EN(L)}$	Input Low Threshold				0.4	V
$I_{EN(H)}$	EN Input Current	AAT3685-1 Only, $V_{EN} = 5V$			10	$\mu A$
$V_{STAT}$	Output Low Voltage	STAT Pin Sinks 4mA			0.4	V
$I_{STAT}$	STAT Pin Current Sink Capability			8.0		mA
$V_{OVP}$	Over-Voltage Protection Threshold			4.4		V
$I_{TK}/I_{CHG}$	Pre-Charge Current	For SETH Mode		10		%
		For SETL Mode		50		
$I_{TERM}/I_{CHG}$	Charge Termination Threshold Current	For SETH Mode		7.5		%
$I_{TERM}/I_{CHG}$	Charge Termination Threshold Current	For SETL Mode		35		%
$I_{TS}$	Current Source from TS Pin		70	80	90	$\mu A$
TS1	TS Hot Temperature Fault	Threshold	310	330	350	mV
		Hysteresis		15		
TS2	TS Cold Temperature Fault	Threshold	2.2	2.3	2.4	V
		Hysteresis		10		
$I_{DATA}$	DATA Pin Sink Current	DATA Pin is Active Low State	3.0			mA
$V_{DATA(H)}$	Input High Threshold		1.6			V
$V_{DATA(L)}$	Input Low Threshold				0.4	V
$SQ_{PULSE}$	Status Request Pulse Width	Status Request	200			ns
$t_{PERIOD}$	System Clock Period			50		$\mu s$
$f_{DATA}$	Data Output Frequency			20		kHz
$T_{OVSD}$	Over-Temperature Shutdown Threshold			145		$^{\circ}C$

1. The AAT3685 output charge voltage is specified over the  $0^{\circ}$  to  $70^{\circ}C$  ambient temperature range; operation over the  $-25^{\circ}C$  to  $+85^{\circ}C$  temperature range is guaranteed by design.

## Typical Characteristics

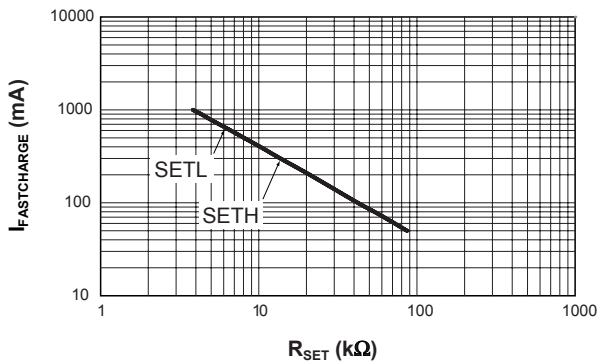
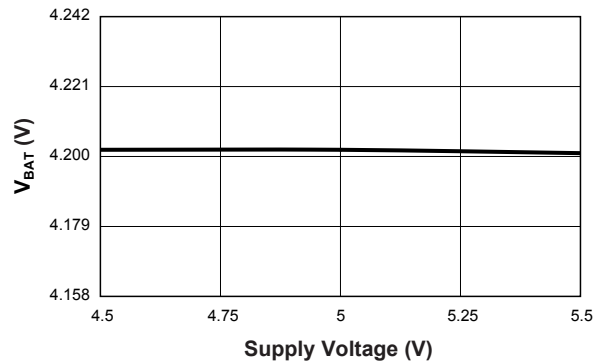
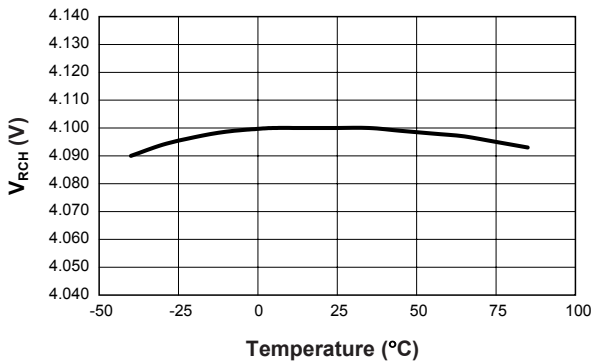
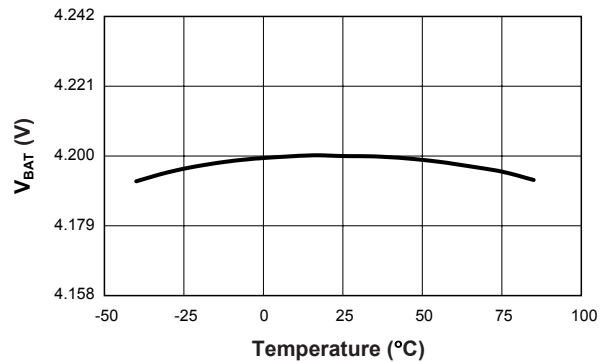
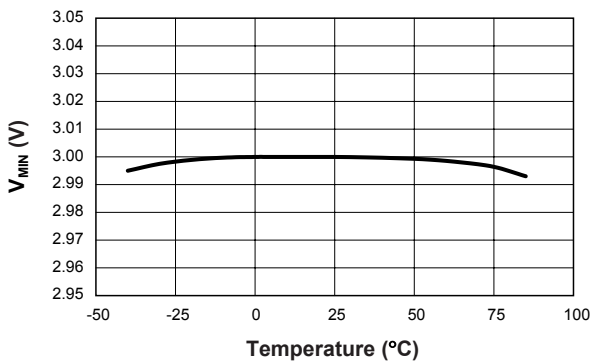
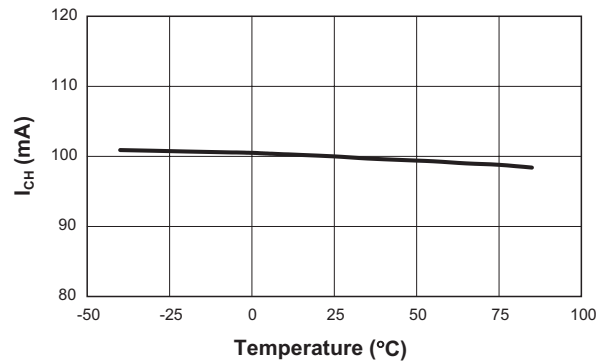
 **$I_{FASTCHARGE}$  vs.  $R_{SET}$** 

**Battery Voltage vs. Supply Voltage**

**Recharge Voltage vs. Temperature**

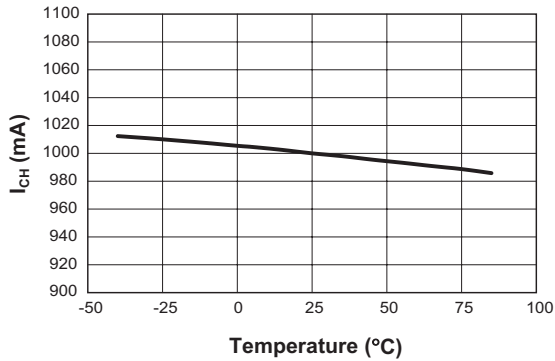
**End of Charge Voltage vs. Temperature**

**Preconditioning Threshold Voltage vs. Temperature**

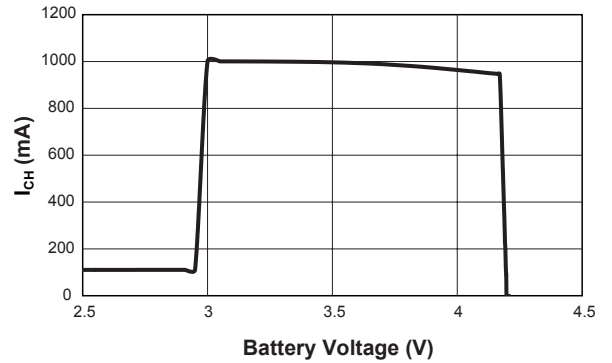
**Preconditioning Charge Current vs. Temperature (SETH;  $R_{SET} = 3.83k\Omega$ )**

### Typical Characteristics

**Fast Charge Current vs. Temperature**  
(SETH; SETH = 3.83k $\Omega$ )



**Charging Current vs. Battery Voltage**  
(SETH; SETH = 3.83k $\Omega$ )



**Charging Current vs. Battery Voltage**  
(SETL; SETL = 40.2k $\Omega$ )

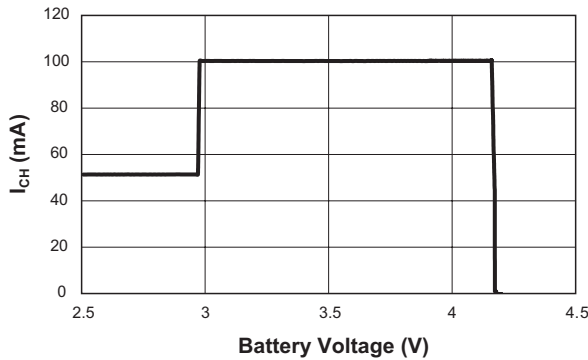

**Fast Charge Current vs. Supply Voltage**  
(SETH; SETH = 3.83k $\Omega$ )

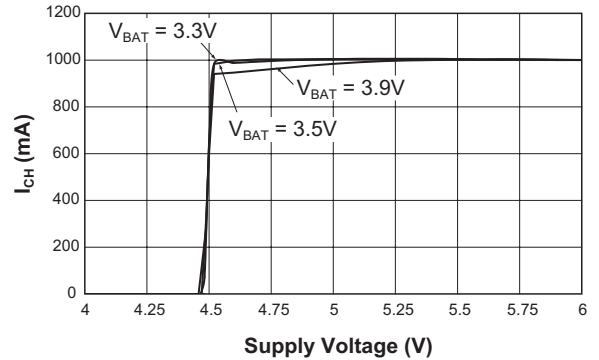

**Fast Charge Current vs. Supply Voltage**  
(SETL; SETL = 40.2k $\Omega$ )

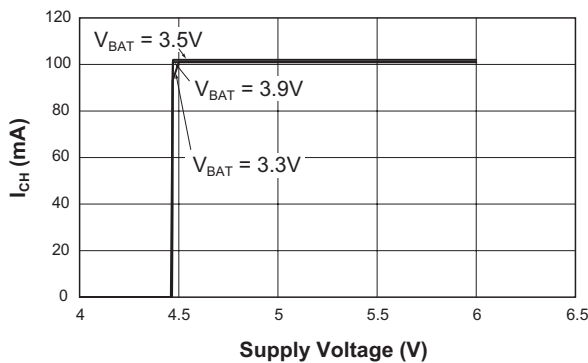

**Fast Charge Current vs. Supply Voltage**  
(SETH; SETH = 3.83k $\Omega$ )

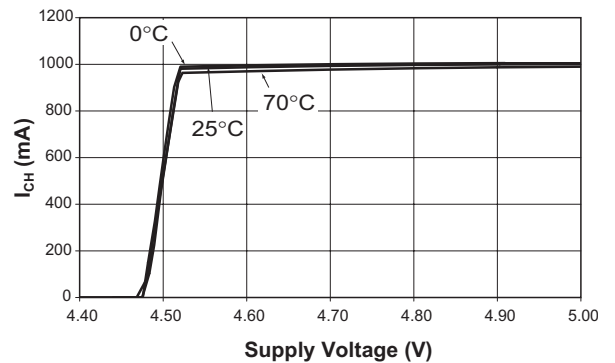

### Typical Characteristics

**V<sub>IH</sub> vs. Supply Voltage**  
EN Pin (Rising)

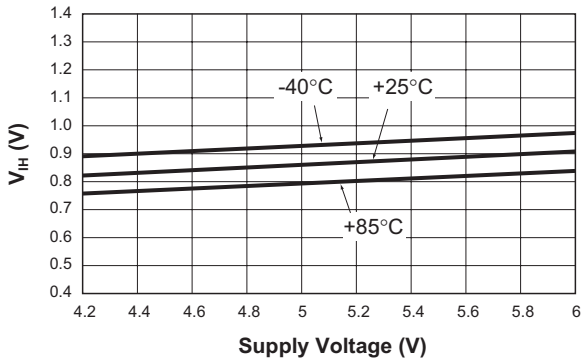

**V<sub>IL</sub> vs. Supply Voltage**  
EN Pin (Falling)

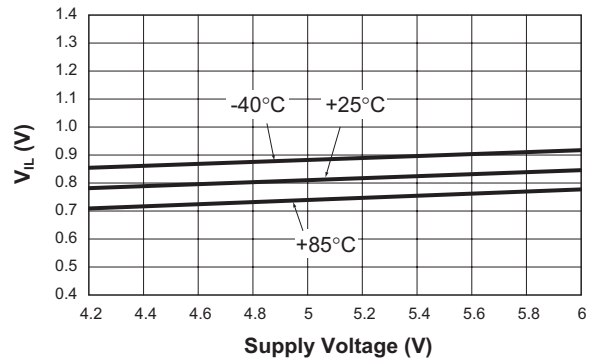

**V<sub>IH</sub> vs. Supply Voltage**  
PWRSEL (Rising)

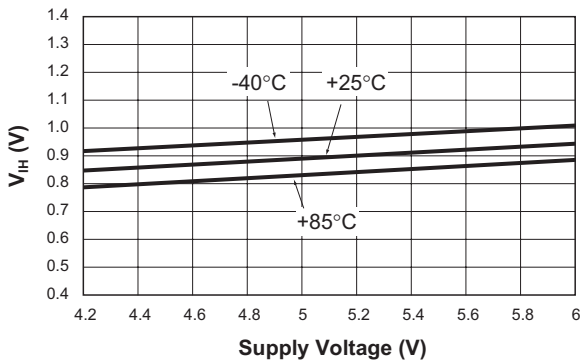

**V<sub>IL</sub> vs. Supply Voltage**  
PWRSEL (Falling)

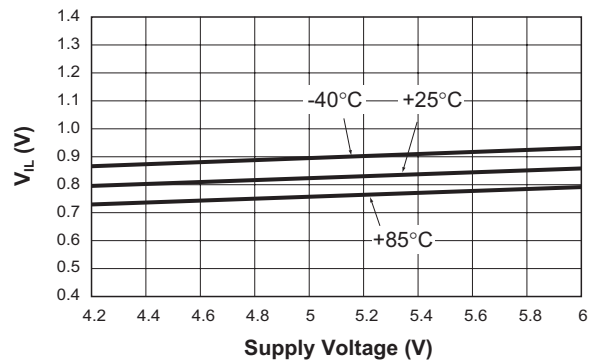

**Supply Current vs. SETH Resistor**

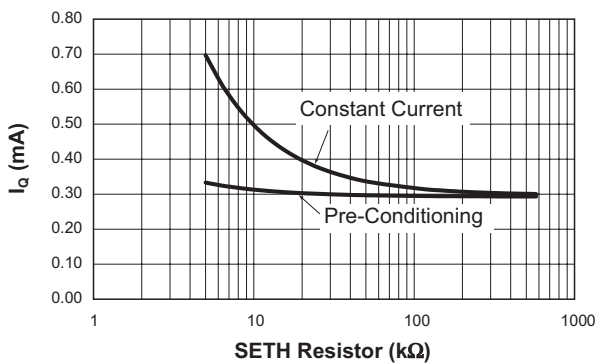

**Charge Current vs. Time**  
(SETH; SETH = 3.83kΩ)

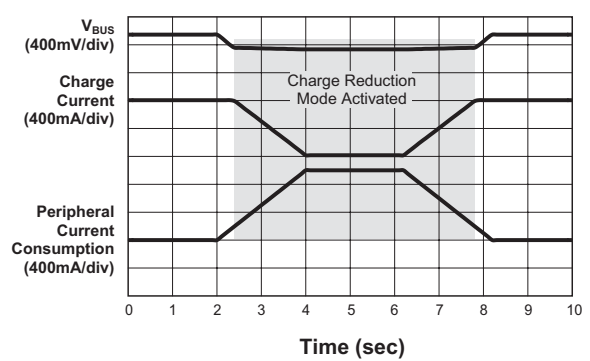



### Typical Characteristics

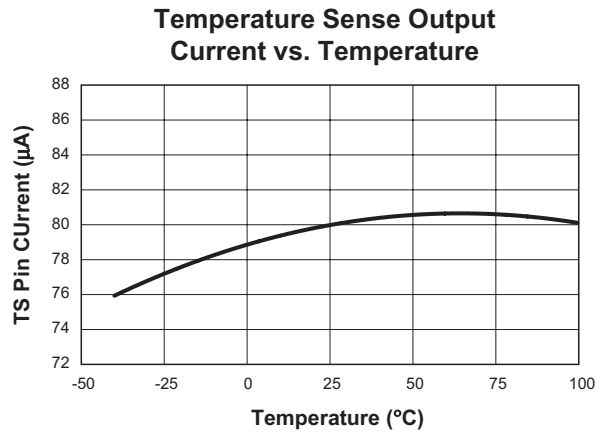

### Functional Block Diagram

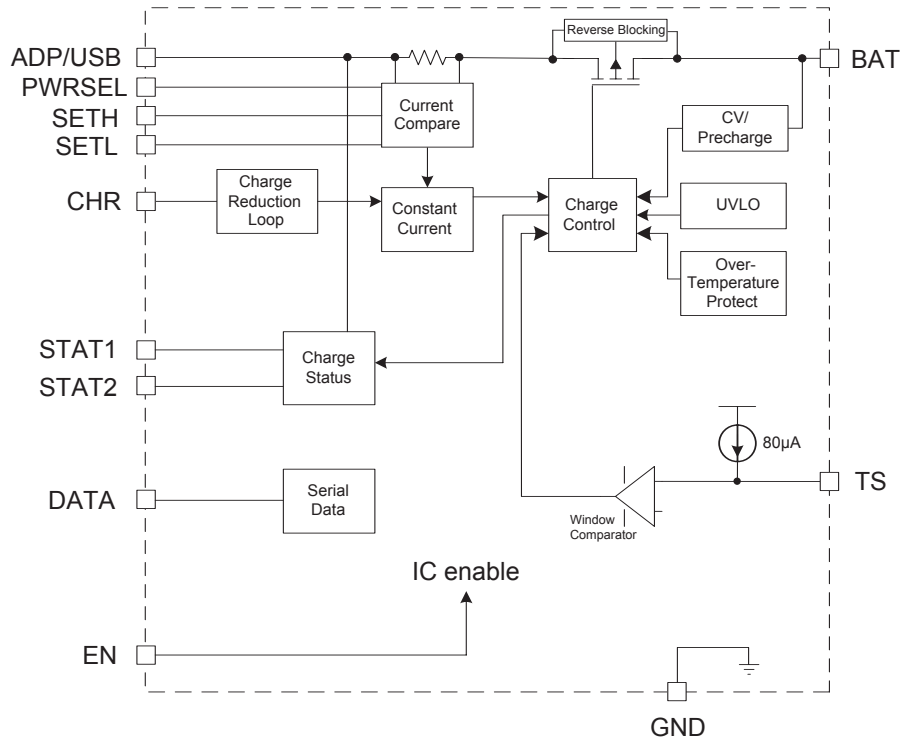

### Functional Description

The AAT3685 is a highly integrated single cell lithium-ion/polymer battery charger IC designed to operate from adapter or USB port  $V_{BUS}$  supplies, while requiring a minimum number of external components. The device precisely regulates battery charge voltage and current for 4.2V lithium-ion/polymer battery cells.

The AAT3685 is specifically designed for being powered from a USB port  $V_{BUS}$  supply, but it can also be powered from any input voltage source capable supplying 4.5V to 5.5V for loads up to 1A. The AAT3685 constant charge current can be externally programmed for two levels, SETH and SETL, for maximum constant current charge levels up to 1A. The SETH/L mode has an automatic Charge Reduction Loop control to allow users to charge the battery with limited available current from a port while maintaining the regulated port voltage. This system assures the battery charge

function will not overload the port while charging if other system demands also share power with the respective port supply.

Status monitor output pins are provided to indicate the battery charge status by directly driving two external LEDs. A serial interface output is available to report 14 various charge states to a system microcontroller.

Battery temperature and charge state are fully monitored for fault conditions. In the event of an over-voltage or over-temperature failure, the device will automatically shut down, thus protecting the charging device, control system, and the battery under charge. In addition to internal charge controller thermal protection, the AAT3685 also provides a temperature sense feedback function (TS pin) from the battery to shut down the device in the event the battery exceeds its own thermal limit during charging. All fault events are reported to the user either by the simple status LEDs or via the DATA pin function.

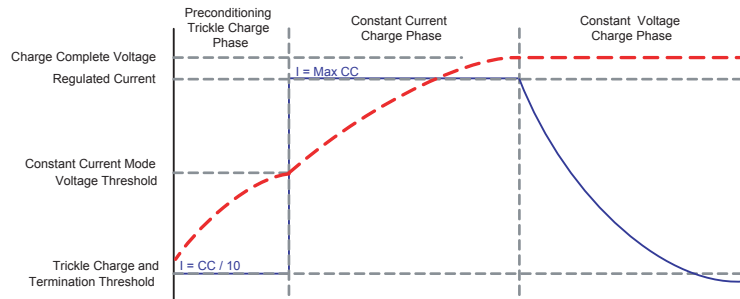

**Figure 1: Current vs. Voltage Profile During Charging Phases.**

### Charging Operation

The AAT3685 has four basic modes for the battery charge cycle and is powered from the input: pre-conditioning/trickle charge; constant current/fast charge; constant voltage; and end of charge. For reference, Figure 1 shows the current versus voltage profile during charging phases.

#### Battery Preconditioning

Before the start of charging, the AAT3685 checks several conditions in order to assure a safe charging environment. The input supply must be above the minimum operating voltage, or under-voltage lockout threshold ( $V_{UVLO}$ ), for the charging sequence to begin. In addition, the cell temperature, as reported by a thermistor connected to the TS pin from the battery, must be within the proper window for safe charging. When these conditions have been met and a battery is connected to the BAT pin, the AAT3685 checks the state of the battery. If the cell voltage is below the Preconditioning Voltage Threshold ( $V_{MIN}$ ), the AAT3685 begins preconditioning the cell.

The battery preconditioning trickle charge current is equal to the fast charge constant current divided by 10. For example, if the programmed fast charge current is 500mA, then the preconditioning mode (trickle charge) current will be 50mA. Cell preconditioning is a safety precaution for a deeply discharged battery and also aids in limiting power dissipation in the pass transistor when the voltage across the device is at the greatest potential.

#### Fast Charge / Constant Current Charging

Battery cell preconditioning continues until the voltage on the BAT pin exceeds the Preconditioning Voltage Threshold ( $V_{MIN}$ ). At this point, the AAT3685 begins the constant current fast charging phase.

The fast charge constant current ( $I_{CC}$ ) amplitude is determined by the selected charge mode SETH or SETL and is programmed by the user via the  $R_{SETH}$  and  $R_{SETL}$  resistors. The AAT3685 remains in constant current charge mode until the battery reaches the voltage regulation point,  $V_{BAT}$ .

#### Constant Voltage Charging

The system transitions to a constant voltage charging mode when the battery voltage reaches output charge regulation threshold ( $V_{BAT}$ ) during the constant current, fast charge phase. The regulation voltage level is factory programmed to 4.2V ( 1%). The charge current in the constant voltage mode drops as the battery cell under charge reaches its maximum capacity.

#### End of Charge Cycle Termination and Recharge Sequence

When the charge current drops to 7.5% of the programmed fast charge current level in the constant voltage mode, the device terminates charging and goes into a sleep state. The charger will remain in a sleep state until the battery voltage decreases to a level below the battery recharge voltage threshold ( $V_{RCH}$ ).

When the input supply is disconnected, the charger will also automatically enter power-saving sleep mode. Only consuming an ultra-low 0.3 $\mu$ A in sleep mode (1 $\mu$ A for AAT3685-1), the AAT3685 minimizes battery drain when it is not charging. This feature is particularly useful in applications where the input supply level may fall below the battery charge or under-voltage lockout level. In such cases where the AAT3685 input voltage drops, the device will enter the sleep mode and automatically resume charging once the input supply has recovered from its fault condition.

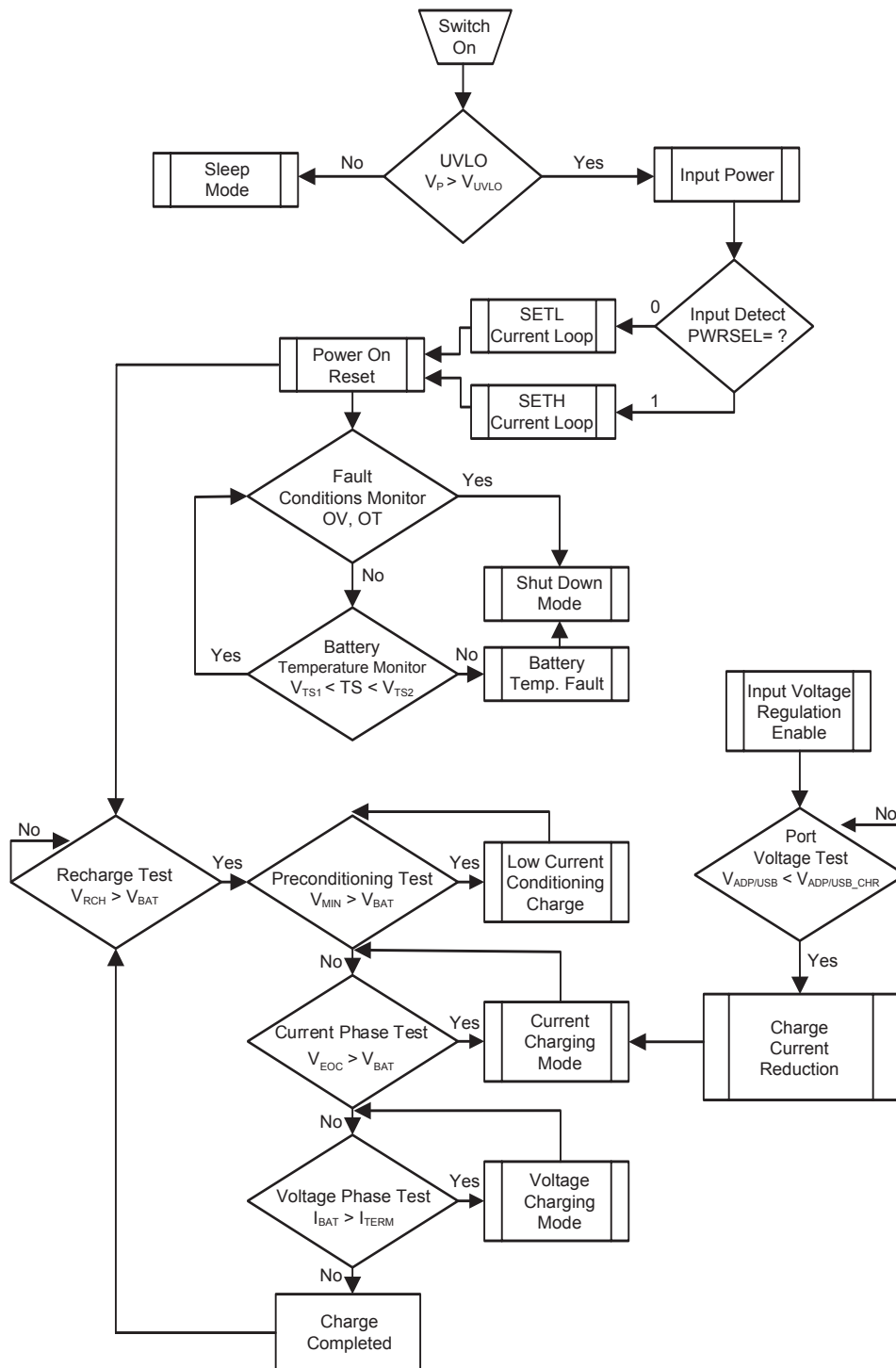
**System Operation Flow Chart**

### Application Information

#### USB System Power Charging

The USB charge mode provides two programmable fast charge levels up to 1A for each, SETH and SETL. The SETH or SETL modes may be externally selected by the select pin (PWRSEL). When the PWRSEL pin is connected to a logic high level, the SETH level will be active. Conversely, when PWRSEL is pulled to a logic low level (ground), the SETL level will be used for fast charging. These two charge levels may be user programmed to any level between 50mA and 1A by selecting the appropriate resistor values for  $R_{SETH}$  and  $R_{SETL}$ . Refer to Table 1 for recommended  $R_{SETH}$  and  $R_{SETL}$  values for the desired input constant current charge levels.

#### Charge Reduction

In many instances, product system designers do not know the real properties of a potential port to be used to supply power to the battery charger. Typical powered USB ports commonly found on desktop and notebook PCs should supply up to 500mA. In the event a port being used to supply the charger is unable to provide the programmed fast charge current, or if the system under charge must also share supply current with other functions, the AAT3685 will automatically reduce USB

fast charge current to maintain port integrity and protect the host system.

The charge reduction system becomes active when the voltage on the input falls below the charge reduction threshold ( $V_{ADP/USB\_CHR}$ ), which is typically 4.5V. Regardless of which charge function is selected (SETH or SETL), the charge reduction system will reduce the fast charge current level in a linear fashion until the voltage sensed on the input recovers above the charge reduction threshold voltage. The charge reduction threshold ( $V_{ADP/USB\_CHR}$ ) may be externally set to a value lower than 4.5V by placing a resistor divider network between  $V_{ADP/USB}$  and ground with the center connected to the CHR pin. The charge reduction feature may be disabled by connecting a 10k $\Omega$  resistor from the CHR pin directly to the ADP/USB input pin.

The following equation may be used to approximate a USB charge reduction threshold below 4.5V:

$$\text{Eq. 1: } V_{ADP/USB\_CHR} = 2.0V \div \frac{R12}{R12 + R11}$$

where  $R11/R12 \ll 1M\Omega$ .

$I_{CC}$	SETH $R_{SET}$ (k $\Omega$ )	SETL $R_{SET}$ (k $\Omega$ )	$I_{CC}$	SETH $R_{SET}$ (k $\Omega$ )	SETL $R_{SET}$ (k $\Omega$ )
50	86.6	86.6	500	8.06	8.06
75	57.6	57.6	600	6.65	6.65
100	42.2	42.2	700	5.62	5.62
200	21.0	20.5	800	4.87	4.87
300	13.7	13.7	900	4.32	4.32
400	10.2	10.2	1000	3.83	3.83

Table 1: Recommended  $R_{SET}$  Values.

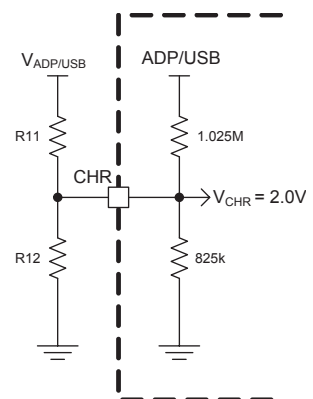

Figure 2: Internal Equivalent Circuit for the CHR Pin.

### Input Charge Inhibit and Resume

The AAT3685 UVLO and power on reset feature will function when the input pin voltage level drops below the UVLO threshold. At this point, the charger will suspend charging and shut down. When power is re-applied to the ADP/USB pin or the UVLO condition recovers, the system charge control will assess the state of charge on the battery cell and will automatically resume charging in the appropriate mode for the condition of the battery.

### Single Path Charging from a Line Adapter or USB Source

Most USB charging applications limit charging current to 500mA due to the limitations of a USB port as a power source. The AAT3685 is capable of, and may be programmed for, constant current charge levels up to 1A. Thus, charging operation is not just restricted to use with USB port supplies. Any power source may be used within the operating voltage limits as specified in the Electrical Characteristics section of this datasheet. This makes the AAT3685 perfect for applications that only have one input path, but may access either a line adapter source or a USB port supply.

In order to fully utilize the power capacity from a line adapter or USB port supply, program the SETH charge rate according to the highest charging current capacity of the two possible sources, providing that neither supply exceeds 1A. A lower charge level may be set with the SETL charge rate and selection of the higher or lower charge rate is controlled via the PWRSEL function. If the programmed charge rate is greater than the current source capacity, there is little danger of system failure because the AAT3685 charge reduction loop will activate to automatically reduce the charging current and maintain a supply voltage set by the CHR threshold. If the input supply is incapable of maintaining an input voltage greater than the under-voltage lockout level of the AAT3685, the charge control will suspend charging until the source supply is capable of supplying the minimum input current to charge. At this point, the AAT3685 will auto-

matically resume charging in the appropriate mode based on the battery cell voltage. In case of an over-temperature condition with a high charge current and large input-to-battery voltage difference, the device will cycle from charging to thermal shut-down and re-charge after temperature drops sufficiently, until the battery is charged to 4.2V.

### Enable / Disable

The AAT3685 provides an enable function to control the charger IC on and off. The enable (EN) pin is an active high. When pulled to a logic low level, the AAT3685 will be shut down and forced into the sleep state. Charging will be halted regardless of the battery voltage or charging state. When the device is re-enabled, the charge control circuit will automatically reset and resume charging functions with the appropriate charging mode based on the battery charge state and measured cell voltage.

### Programming Charge Current

The fast charge constant current charge level for the ADP/USB input is programmed with set resistors placed between the SETH and SETL pins and ground. The accuracy of the fast charge, as well as the preconditioning trickle charge current, is dominated by the tolerance of the set resistors used. For this reason, 1% tolerance metal film resistors are recommended for programming the desired constant current level.

The fast charge constant current charge control provides for two current set levels, SETH and SETL. The PWRSEL pin is used to select the high or low charge current levels. When the PWRSEL pin is pulled to a voltage level above the  $V_{PWRSEL(H)}$  threshold, the SETH current level will be selected. Conversely, this pin should be pulled below the  $V_{PWRSEL(L)}$  to enable the SETL charge level. These two charge levels may be set to any level between 50mA and 1A, depending upon the system design requirements for a given charge application. Refer to Table 1 and Figure 3 for recommended  $R_{SETH}$  and  $R_{SETL}$  values.

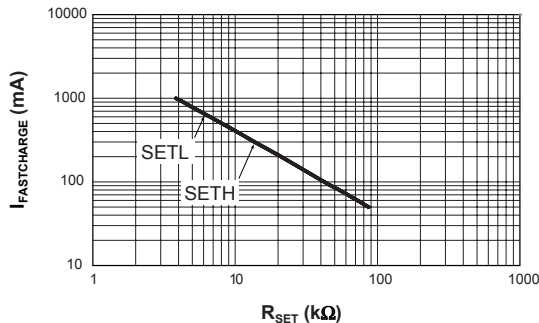

Figure 3: I<sub>FASTCHARGE</sub> vs. R<sub>SET</sub>

## Protection Circuitry

### Over-Voltage Protection

An over-voltage event is defined as a condition where the voltage on the BAT pin exceeds the maximum battery charge voltage and is set by the over-voltage protection threshold ( $V_{OVP}$ ). If an over-voltage condition occurs, the AAT3685 charge control will shut down the device until voltage on the BAT pin drops below the over-voltage protection threshold ( $V_{OVP}$ ). The AAT3685 will resume normal charging operation after the over-voltage condition is removed. During an over-voltage event, the STAT LEDs will report a system fault; the actual fault condition may also be read via the DATA pin signal.

### Over-Temperature Shutdown

The AAT3685 has a thermal protection control circuit which will shut down charging functions should the internal die temperature exceed the preset thermal limit threshold.

### Battery Temperature Fault Monitoring

In the event of a battery over-temperature condition, the charge control will turn off the internal pass device and report a battery temperature fault on the DATA pin function. The STAT LEDs will also display a system fault. After the system recovers from a temperature fault, the device will resume charging operation.

The AAT3685 checks battery temperature before starting the charge cycle, as well as during all stages of charging. This is accomplished by monitoring the voltage at the TS pin. This system is intended for use negative temperature coefficient (NTC) thermistors which are typically integrated into the battery package. Most commonly used NTC thermistors used in battery packs are approximately 10kΩ at room temperature (25°C). The TS pin has been specifically designed to source 80μA of current to the thermistor. The voltage on the TS pin that results from the resistive load should stay within a window from 335mV to 2.32V. If the battery becomes too hot during charging due to an internal fault, the thermistor will heat up and reduce in value, thus pulling the TS pin voltage lower than the TS1 threshold, and the AAT3685 will halt charging and signal the fault condition. If the use of the TS pin function is not required by the system, it should be terminated to ground using a 10kΩ resistor. Alternatively, on the AAT3685-1, the TS pin may be left open.

## Battery Charge Status Indication

The AAT3685 indicates the status of the battery under charge with two different systems. First, the device has two status LED driver outputs. These two LEDs can indicate simple functions such as no battery charge activity, battery charging, charge complete, and charge fault. The AAT3685 also provides a bi-directional data reporting function so that a system microcontroller may interrogate the DATA pin and read any one of 14 system states.

### Status Indicator Display

Simple system charging status may be displayed using one or two LEDs in conjunction with the STAT1 and STAT2 pins on the AAT3685. These two pins are simple switches to connect the display LED cathodes to ground. It is not necessary to use both display LEDs if a user simply wants to have a single lamp to show "charging" or "not charging."

This can be accomplished by just using the STAT1 pin and a single LED. Using two LEDs and both STAT pins simply gives the user more information for charging states. Refer to Table 2 for LED display definitions.

Event Description	STAT1	STAT2
Charge Disabled or Low Supply	Off	Off
Charge Enabled Without Battery	Flash <sup>1</sup>	Flash <sup>1</sup>
Battery Charging	On	Off
Charge Completed	Off	On
Fault	On	On

**Table 2: LED Display Status Conditions.**

The LED anodes should be connected to  $V_{ADP/USB}$ . The LEDs should be biased with as little current as necessary to create reasonable illumination; therefore, a ballast resistor should be placed between each of the LED cathodes and the STAT1/2 pins. LED current consumption will add to the over-thermal power budget for the device package, hence it is recommended to keep the LED drive current to a minimum. 2mA should be sufficient to drive most low-cost green, red, or multi-color LEDs. It is not recommended to exceed 8mA for driving an individual status LED.

The required ballast resistor value can be estimated using the following formulas:

$$\text{Eq. 2: } R_{B(\text{STAT1/2})} = \frac{(V_{\text{ADP/USB}} - V_{F(\text{LED})})}{I_{\text{LED}(\text{STAT1/2})}}$$

Example:

$$R_{B(\text{STAT1})} = \frac{(5.0\text{V} - 2.0\text{V})}{2\text{mA}} = 1.5\text{k}\Omega$$

Note: Red LED forward voltage ( $V_F$ ) is typically 2.0V @ 2mA.

Table 2 shows the four status LED display conditions.

### Digital Charge Status Reporting

The AAT3685 has a comprehensive digital data reporting system by use of the DATA pin feature.

This function can provide detailed information regarding the state of the charging system. The DATA pin is a bi-directional port which will read back a series of data pulses when the system microcontroller asserts a request pulse. This single strobe request protocol will invoke one of 14 possible return pulse counts in which the microcontroller can look up based on the serial report shown in Table 3.

The DATA pin function is active low and should normally be pulled high to  $V_{ADP/USB}$ . This data line may also be pulled high to the same level as the high state for the logic I/O port on the system microcontroller. In order for the DATA pin control circuit to generate clean sharp edges for the data output and to maintain the integrity of the data timing for the system, the pull-up resistor on the data line should be low enough in value so that the DATA signal returns to the high state without delay. If the value of the pull-up resistor used is too high, the strobe pulse from the system microcontroller may exceed the maximum pulse time and the DATA output control could issue false status reports. A 1.5k $\Omega$  resistor is recommended when pulling the DATA pin high to 5.0V at the  $V_{USB}$  input. If the data line is pulled high to a voltage level less than 5.0V, the pull-up resistor may be calculated based on a recommended minimum pull-up current of 3mA. Use the following formula:

$$\text{Eq. 3: } R_{\text{PULL-UP}} \leq \frac{V_{\text{PULL-UP}}}{3\text{mA}}$$

1. Flashing rate depends on output capacitance.



N	DATA Report Status
1	Chip Over-Temperature Shutdown
2	Battery Temperature Fault
3	Over-Voltage Turn Off
4	Not Used
5	Not Used
6	Not Used
7	Not Used
8	Not Used
9	Not Used
10	Not Used
11	Not Used
12	Not Used
13	SETH Battery Condition Mode
14	SETH Charge Reduction in Constant Current Mode
15	SETH Constant Current Mode
16	SETH Constant Voltage Mode
17	SETH End of Charging
18	SETL Battery Condition Mode
19	SETL Charge End of Charging Reduction in Constant Current Mode
20	SETL Constant Current Mode
21	SETL Constant Voltage Mode
22	SETL End of Charging
23	Data Report Error

**Table 3: Serial Data Report Table.**

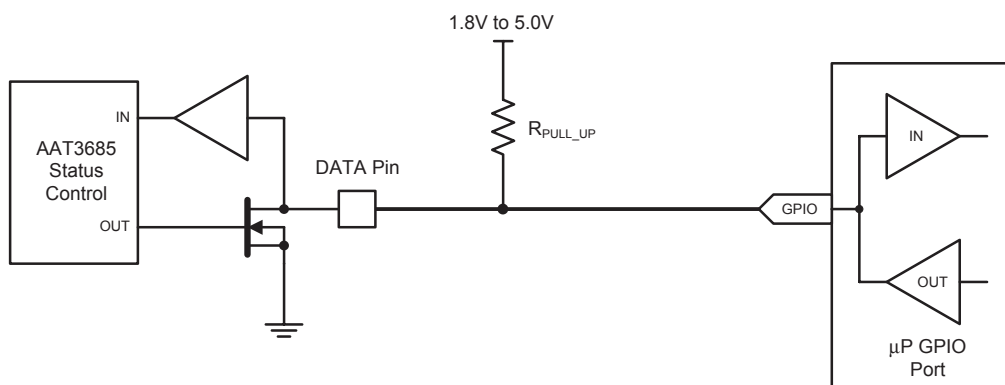

**Figure 4: Data Pin Application Circuit.**

### Data Timing

The system microcontroller should assert an active low data request pulse for minimum duration of 200ns; this is specified by  $T_{LO(DATA)}$ . Upon sensing the rising edge of the end of the data request pulse,

the AAT3685 status data control will reply the data word back to the system microcontroller after a delay specified by the data report time specification  $T_{DATA(RPT)}$ . The period of the following group of data pulses will be specified by the  $T_{DATA}$  specification.

### Timing Diagram

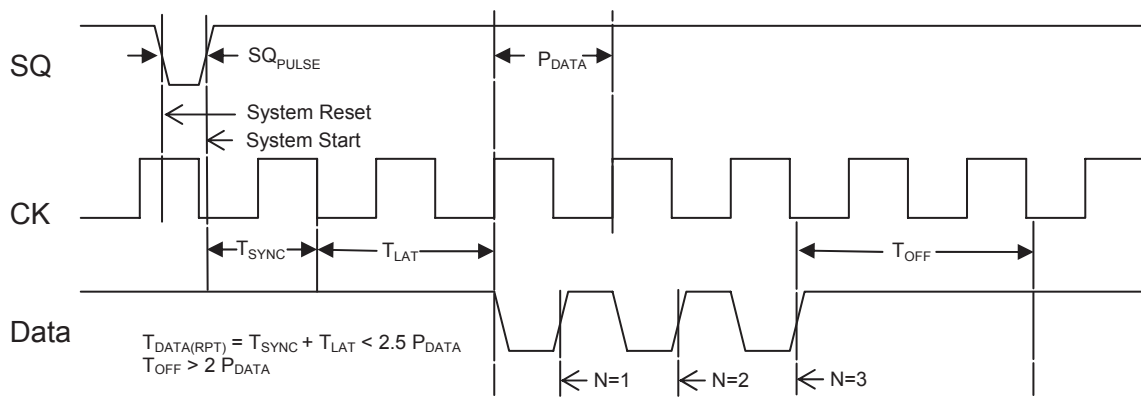

### Thermal Considerations

The AAT3685 is packaged in a Pb-free, 3x3mm TDFN package which can provide up to 2.0W of power dissipation when it is properly bonded to a printed circuit board and has a maximum thermal resistance of 50°C/W. Many considerations should be taken into account when designing the printed circuit board layout, as well as the placement of the charger IC package in proximity to other heat generating devices in a given application design. The ambient temperature around the charger IC will also have an affect on the thermal limits of a battery charging application. The maximum limits that can be expected for a given ambient condition can be estimated by the following discussion.

First, the maximum power dissipation for a given situation should be calculated:

$$\text{Eq. 4: } P_D = [(V_{IN} - V_{BAT}) \cdot I_{CC} + (V_{IN} \cdot I_{OP})]$$

Where:

$P_D$  = Total Power Dissipation by the Device

$V_{IN}$  = Input Voltage Level,  $V_{ADP/USB}$

$V_{BAT}$  = Battery Voltage as Seen at the BAT Pin

$I_{CC}$  = Maximum Constant Fast Charge Current Programmed for the Application

$I_{OP}$  = Quiescent Current Consumed by the Charger IC for Normal Operation

Next, the maximum operating ambient temperature for a given application can be estimated based on the thermal resistance of the 3x3mm TDFN package when sufficiently mounted to a PCB layout and the internal thermal loop temperature threshold.

$$\text{Eq. 5: } T_A = T_J - (\theta_{JA} \cdot P_D)$$

Where:

- $T_A$  = Ambient Temperature in Degrees C
- $T_J$  = Maximum Device Junction Temperature Protected by the Thermal Limit Control
- $P_D$  = Total Power Dissipation by the Device
- $\theta_{JA}$  = Package Thermal Resistance in °C/W

Example:

For an application where the fast charge current is set to 500mA,  $V_{USB} = 5.0V$  and the worst case battery voltage at 3.0V, what is the maximum ambient temperature at which the thermal limiting will become active?

Given:

- $V_{USB} = 5.0V$
- $V_{BAT} = 3.0V$
- $I_{CC} = 500mA$
- $I_{OP} = 0.75mA$
- $T_J = 140^\circ C$
- $\theta_{JA} = 50^\circ C/W$

Using Equation 4, calculate the device power dissipation for the stated condition:

**Eq. 6:**  $P_D = (5.0V - 3.0V)(500mA) + (5.0V \cdot 0.75mA)$   
 $= 1.00375W$

The maximum ambient temperature before the AAT3685 thermal limit protection will shut down charging can now be calculated using Equation 5:

**Eq. 7:**  $T_A = 140^\circ C - (50^\circ C/W \cdot 1.00375W)$   
 $= 89.81^\circ C$

Therefore, under the stated conditions for this worst case power dissipation example, the AAT3685 will suspend charging operations when the ambient operating temperature rises above 89.81°C.

## Capacitor Selection

### Input Capacitor

In general, it is good design practice to place a decoupling capacitor between the ADP/USB pin and ground. An input capacitor in the range of 1µF to 22µF is recommended. If the source supply is unregulated, it may be necessary to increase the capacitance to keep the input voltage above the under-voltage lockout threshold during device enable and when battery charging is initiated.

If the AAT3685 input is to be used in a system with an external power supply source rather than a USB port  $V_{BUS}$ , such as a typical AC-to-DC wall adapter, then a  $C_{IN}$  capacitor in the range of 10µF should be used. A larger input capacitor in this application will minimize switching or power bounce effects when the power supply is "hot plugged" in. Likewise, a 10µF or greater input capacitor is recommended for the USB input to help buffer the effects of USB source power switching noise and input cable impedance.

### Output Capacitor

The AAT3685 only requires a 1µF ceramic capacitor on the BAT pin to maintain circuit stability. This value should be increased to 10µF or more if the battery connection is made any distance from the charger output. If the AAT3685 is to be used in applications where the battery can be removed from the charger, such as in the case of desktop charging cradles, an output capacitor greater than 10µF may be required to prevent the device from cycling on and off when no battery is present.

## Printed Circuit Board Layout Considerations

For the best results, it is recommended to physically place the battery pack as close as possible to the AAT3685 BAT pin. To minimize voltage drops on the PCB, keep the high current carrying traces adequately wide. For maximum power dissipation of the AAT3685 3x3mm TDFN package, the metal substrate should be solder bonded to the board. It is also recommended to maximize the substrate contact to the PCB ground plane layer to further increase local heat dissipation. Refer to the AAT3685 evaluation board for a good layout example (see Figures 5 and 6).

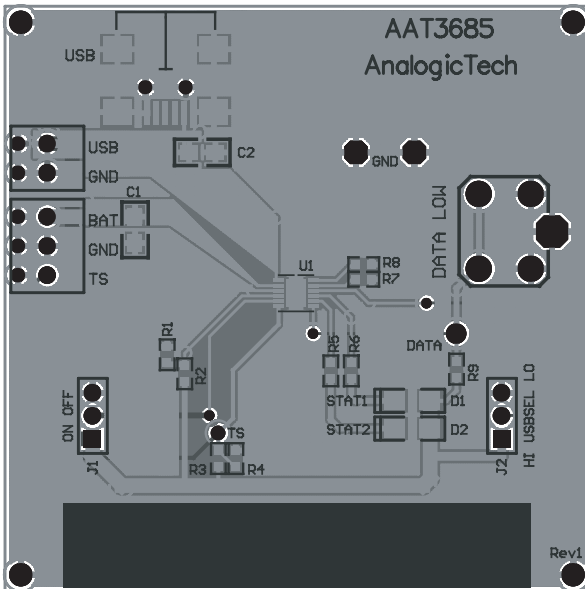
**AAT3685 Evaluation Board Layout**

**Figure 5: AAT3685 Evaluation Board Component Side Layout.**

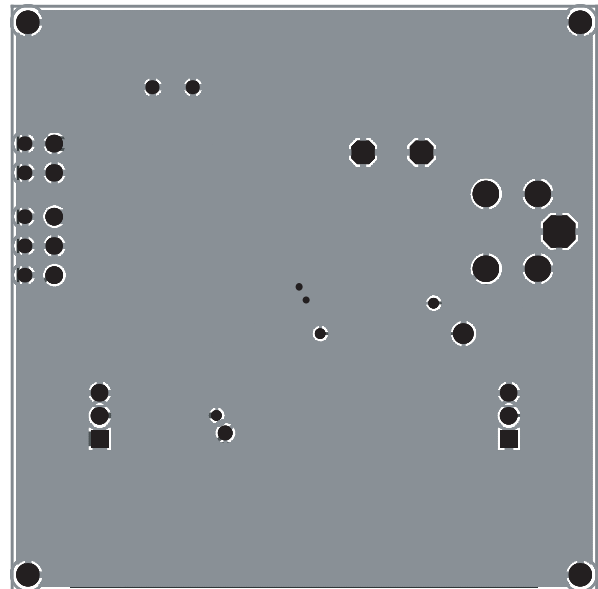

**Figure 6: AAT3685 Evaluation Board Solder Side Layout.**

## AAT3685 Evaluation Board Schematic Diagram

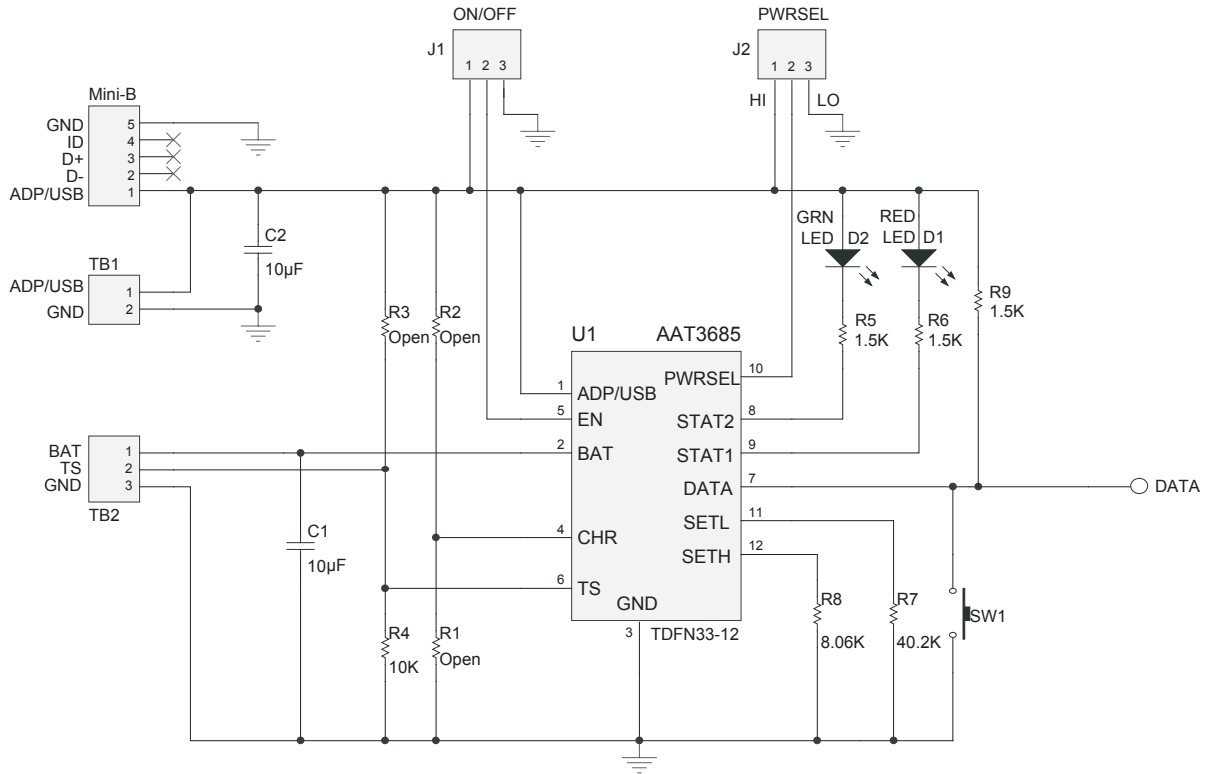

### AAT3685 Evaluation Board Bill of Materials (BOM)

Quantity	Description	Desig.	Footprint	Manufacturer	Part Number
1	Test Pin	DATA	PAD	Mill-Max	6821-0-0001-00-00-08-0
1	Connecting Terminal Block, 2.54mm, 2 Pos	USB,GND	TBLOK2	Phoenix Contact	277-1274-ND
1	Connecting Terminal Block, 2.54mm, 3 Pos	BAT, GND, TS	TBLOK3	Phoenix Contact	277-1273-ND
1	USB 2.0 Receptacle, 5 Pos	USB	USB-MINI-B	Hirose Electronic Co. Ltd.	H2959CT-ND
2	Capacitor, Ceramic, 10µF 6.3V 10% X5R 0805	C1, C2	0805	MuRata	490-1717-1-ND
1	Typical Red LED, Super Bright	D1	1206LED	Chicago Miniature Lamp	CMD15-21SRC/TR8
1	Typical Green LED	D2	1206LED	Chicago Miniature Lamp	CMD15-21VGC/TR8
2	Header, 3-Pin	J1, J2	HEADER2MM-3	Sullins	6821-0-0001-00-00-08-0
1	Resistor, 10kΩ 1/16W 5% 0603 SMD	R4	0603	Panasonic/ECG	P10KCFCT-ND
3	Resistor, 1.5kΩ 1/16W 1% 0603 SMD	R5, R6, R9	0603	Panasonic/ECG	P1.5KCGCT-ND
1	Resistor, 40.2kΩ 1/16W 1% 0603 SMD	R7	0603	Panasonic/ECG	P40.2KHTR-ND
1	Resistor, 8.06kΩ 1/16W 1% 0603 SMD	R8	0603	Panasonic/ECG	P8.06KHCT-ND
1	Switch Tact 6mm SPST H = 5.0mm	SW1	SWITCH	ITT Industries/ C&K Div.	CKN9012-ND
1	AAT3685 Lithium-Ion/ Polymer Battery Charger	U1	TDFN33-12	AnalogicTech	AAT3685IWP

### Ordering Information

Package	Marking <sup>1</sup>	Part Number (Tape and Reel) <sup>2</sup>
TDFN33-12	RNXY	<b>AAT3685IWP-4.2-T1</b>
TDFN33-12	TMXY	<b>AAT3685IWP-4.2-1-T1</b>



All AnalogicTech products are offered in Pb-free packaging. The term “Pb-free” means semiconductor products that are in compliance with current RoHS standards, including the requirement that lead not exceed 0.1% by weight in homogeneous materials. For more information, please visit our website at <http://www.analogictech.com/pbfree>.

### Package Information

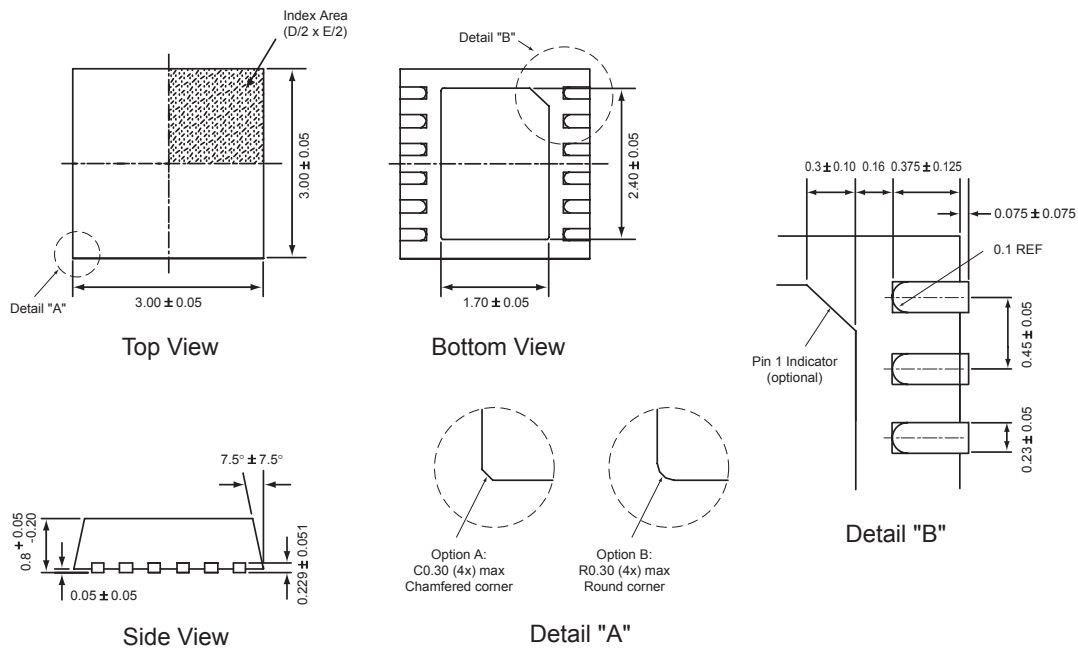

All dimensions in millimeters.

1. XYY = assembly and date code.
2. Sample stock is generally held on part numbers listed in **BOLD**.

© Advanced Analogic Technologies, Inc.

AnalogicTech cannot assume responsibility for use of any circuitry other than circuitry entirely embodied in an AnalogicTech product. No circuit patent licenses, copyrights, mask work rights, or other intellectual property rights are implied. AnalogicTech reserves the right to make changes to their products or specifications or to discontinue any product or service without notice. Customers are advised to obtain the latest version of relevant information to verify, before placing orders, that information being relied on is current and complete. All products are sold subject to the terms and conditions of sale supplied at the time of order acknowledgement, including those pertaining to warranty, patent infringement, and limitation of liability. AnalogicTech warrants performance of its semiconductor products to the specifications applicable at the time of sale in accordance with AnalogicTech's standard warranty. Testing and other quality control techniques are utilized to the extent AnalogicTech deems necessary to support this warranty. Specific testing of all parameters of each device is not necessarily performed.

AnalogicTech and the AnalogicTech logo are trademarks of Advanced Analogic Technologies Incorporated. All other brand and product names appearing in this document are registered trademarks or trademarks of their respective holders.

**Advanced Analogic Technologies, Inc.**  
 830 E. Arques Avenue, Sunnyvale, CA 94085  
 Phone (408) 737-4600  
 Fax (408) 737-4611