

CMM1200-BD

2.0 to 6.0 GHz
GaAs MMIC Low-Noise Amplifier



2.0 to 6.0 GHz GaAs MMIC Low-Noise Amplifier

**Advanced Product Information
May 2005 V1.5**

(1 of 5)

Features

- ❑ **Small Size: 1.60 x 1.55 x 0.076 mm**
- ❑ **Integrated On-Chip Drain Bias Coil**
- ❑ **Integrated On-Chip DC Blocking**
- ❑ **Single Bias Operation**
- ❑ **Directly Cascadable – Fully Matched, Novel Feedback & Distributed Amplifier Design**
- ❑ **P1dB: 15.5 dBm @ 6 GHz, Typ.**
- ❑ **High Linear Gain: 17.5 dB Typ.**
- ❑ **Noise Figure: 3.3 dB Typ. @ 6 GHz**
- ❑ **pHEMT Technology**
- ❑ **Silicon Nitride Passivation**

Chip Diagram

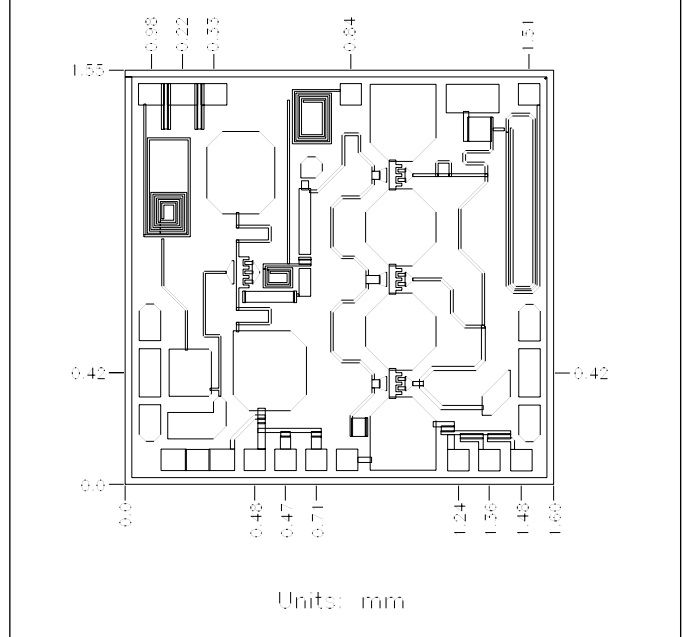

Specifications (TA = 25°C, Vdd = 5V) ¹

Parameters	Units	Min	Typ	Max
Frequency Range	GHz	2.0		6.0
Linear Gain	dB	16.0	17.5	
Gain Variation (over operating frequency)	±dB			2.0
Power Output (@1 dB Gain Compression)	dBm	14.0	15.5	
P1dB Variation (over operating frequency)	dBm			1.0
Saturated Output Power	dBm	19.0		23.0
Third Order Intercept Point (@ 6 GHz)	dBm		25.5	
Second Order Intercept Point (@ 6 GHz)	dBm		41.0	
Noise Figure (@6 GHz)	dB		3.3	3.8
Input Return Loss ²	dB			-9.5
Output Return Loss ²	dB			-12.0
Current	mA	85	100	115
Thermal Resistance	°C/W		34.0	
Stability	Unconditionally Stable			

Notes: 1. Tested on Celeritek connectorized evaluation board.
 2. Measured on wafer.

Absolute Maximum Ratings ¹

Parameter	Rating
Drain Voltage	4.5V (min.) / 8.0V (max.)
Drain Current	150 mA
Continuous Power Dissipation	1.2 W
Input Power	10 dBm
Storage Temperature	-50°C to +150°C
Channel Temperature	175°C
Operating Backside Temperature ²	-40°C Min.

Notes: 1. Operation outside these limits can cause permanent damage.
 2. Calculation maximum operating temperature:
 $T_{max} = 175 - (P_{dis} [W] \times 34) [°C]$.

Die Attach and Bonding Procedures

Die Attach: Eutectic die attach is recommended. For eutectic die attach: Preform: AuSn (80% Au, 20% Sn); Stage Temperature: 290°C, ±5°C; Handling Tool: Tweezers; Time: 1 min or less.

Wire Bonding: Wire Size: 0.7 to 1.0 mil in diameter (pre-stressed); Thermocompression bonding is preferred over thermosonic bonding. For thermocompression bonding: Stage Temperature: 250°C; Bond Tip Temperature: 150°C; Bonding Tip Pressure: 18 to 40 gms depending on size of wire.

Typical On-Wafer Scattering Parameters (Vd = +5.0V, Icc = 101 mA, T = 23°C, device in a 50 ohm system)

Frequency (MHz)	S ₁₁		S ₂₁		S ₁₂		S ₂₂	
	(Mag)	(Ang)	(Mag)	(Ang)	(Mag)	(Ang)	(Mag)	(Ang)
0.10	0.813	-0.57	0.001	0.00	0.000	0.00	0.970	-0.23
1.00	-0.461	0.50	-1.411	-3.07	0.004	0.00	-0.474	-0.44
1.90	0.060	0.07	1.612	7.22	-0.001	0.00	-0.245	-0.03
2.20	0.041	-0.01	5.064	6.32	0.000	0.00	-0.192	0.04
2.50	0.008	-0.05	7.462	3.94	-0.001	0.00	-0.127	0.04
3.40	-0.021	-0.09	7.667	-3.82	0.000	0.00	-0.077	0.00
3.70	-0.023	-0.10	6.413	-5.62	0.001	0.00	-0.074	-0.01
4.00	-0.027	-0.13	4.857	-6.95	0.002	0.00	-0.075	-0.02
4.90	-0.059	-0.20	-0.337	-8.14	0.003	0.00	-0.092	-0.03
5.20	-0.085	-0.22	-1.893	-7.81	0.003	0.00	-0.099	-0.03
5.50	-0.111	-0.24	-3.305	-7.21	0.004	0.00	-0.106	-0.03
5.80	-0.140	-0.26	-4.492	-6.28	0.004	0.00	-0.117	-0.03
6.10	-0.179	-0.26	-5.314	-5.42	0.005	0.00	-0.126	-0.01
7.00	-0.267	-0.25	-7.084	-2.16	0.005	0.00	-0.128	0.02
7.90	-0.338	-0.20	-7.165	1.27	0.004	0.00	-0.117	0.05
8.20	-0.355	-0.18	-6.874	2.35	0.004	0.00	-0.109	0.06
8.50	-0.368	-0.16	-6.436	3.37	0.004	0.00	-0.100	0.07
9.10	-0.387	-0.11	-5.152	5.20	0.003	-0.01	-0.077	0.08
10.00	-0.395	-0.06	-2.289	7.12	0.001	-0.01	-0.036	0.09
10.90	-0.392	-0.01	1.328	7.55	0.000	-0.01	0.000	0.07
12.10	-0.394	0.05	5.852	5.16	-0.004	-0.01	0.027	0.02
13.00	-0.394	0.12	7.603	1.63	-0.007	-0.01	0.024	-0.02
13.90	-0.368	0.21	7.341	-2.28	-0.009	0.00	0.002	-0.04
14.50	-0.324	0.28	6.104	-4.58	-0.009	0.00	-0.016	-0.05
15.10	-0.253	0.34	4.167	-6.32	-0.010	0.00	-0.033	-0.04
16.00	-0.101	0.39	0.436	-7.50	-0.010	0.00	-0.053	-0.03
17.20	0.125	0.35	-4.701	-5.86	-0.006	0.01	-0.072	0.00
18.10	0.262	0.25	-7.183	-2.26	-0.003	0.01	-0.065	0.04
19.00	0.369	0.13	-7.082	2.49	0.003	0.01	-0.021	0.09
20.20	0.501	-0.10	-1.719	6.64	0.010	0.01	0.117	0.07
21.10	0.481	-0.36	2.707	4.90	0.012	0.00	0.152	-0.06
22.00	0.348	-0.53	4.002	1.55	0.008	-0.01	0.080	-0.14
23.20	0.198	-0.65	2.532	-1.66	0.000	-0.01	-0.012	-0.12
24.10	0.078	-0.78	0.354	-2.02	-0.005	-0.01	-0.019	-0.09
25.00	-0.150	-0.85	-0.597	-0.90	-0.006	0.00	-0.022	-0.09
26.20	-0.437	-0.73	-0.379	-0.17	-0.006	0.00	-0.033	-0.07
26.80	-0.537	-0.60	-0.265	-0.05	-0.004	0.00	-0.033	-0.07
28.00	-0.204	-0.39	-0.136	-0.02	-0.002	0.00	-0.028	-0.05
29.20	-0.466	-0.67	-0.076	0.03	-0.003	0.00	-0.011	-0.04
30.10	-0.637	-0.58	-0.040	0.03	-0.001	0.00	0.011	-0.04

S-Parameter Data Files are available on-line at: www.celeritek.com



Typical Narrow and Wideband S-Parameter Performance

CMM1200 Typical Small-Signal Data
RF-probe Test; 5V, 100mA

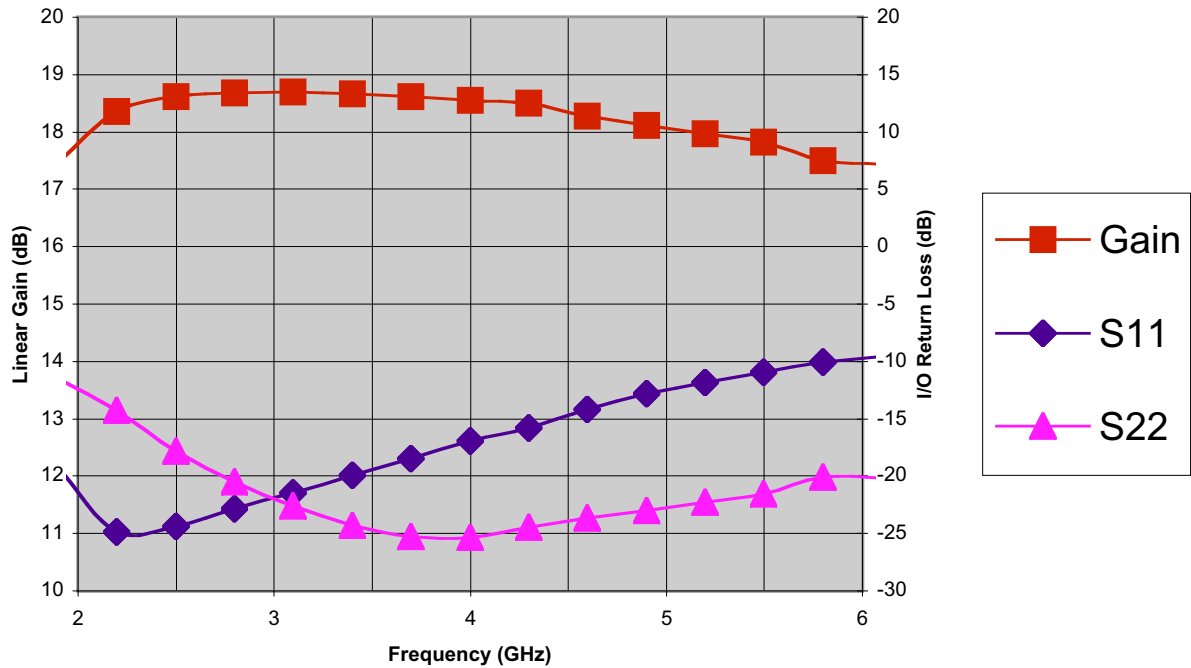

CMM1200 Typical On-wafer S-parameter Data
5V, 100mA, Low Current

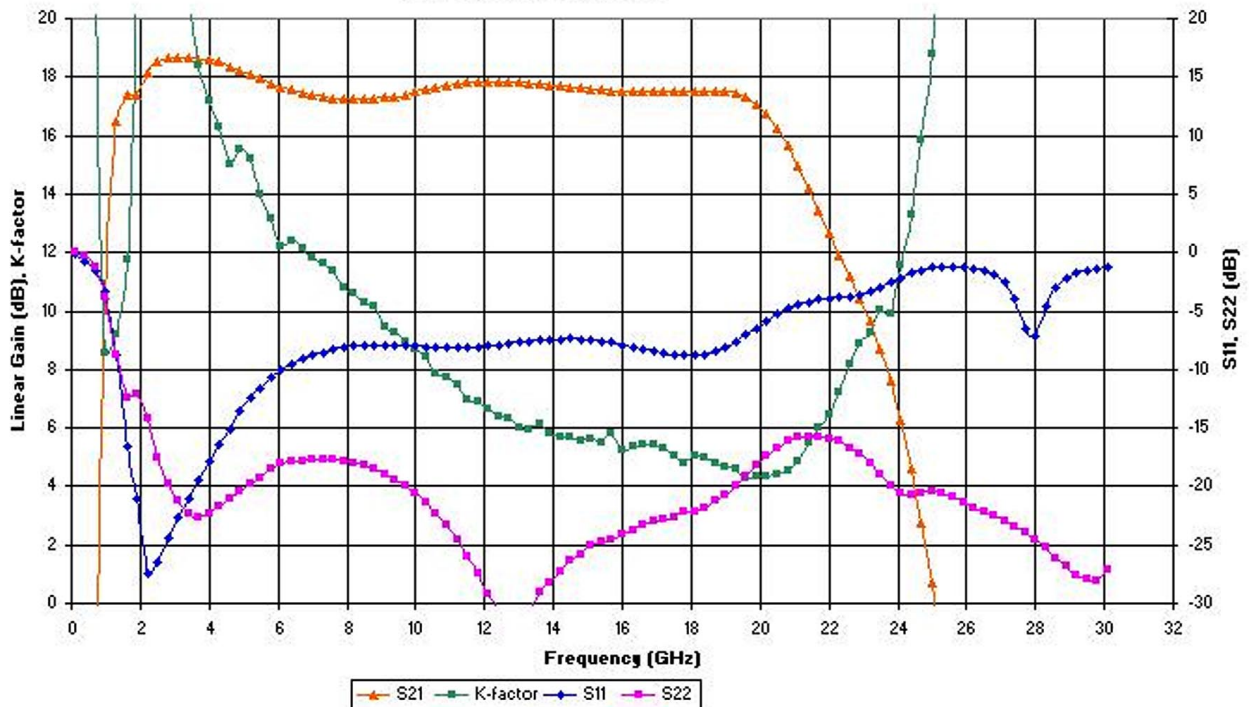

Typical Noise and Power Performance

CMM1200 Typical Noise Figure Data
Connectorized Fixture; Vdd=5V

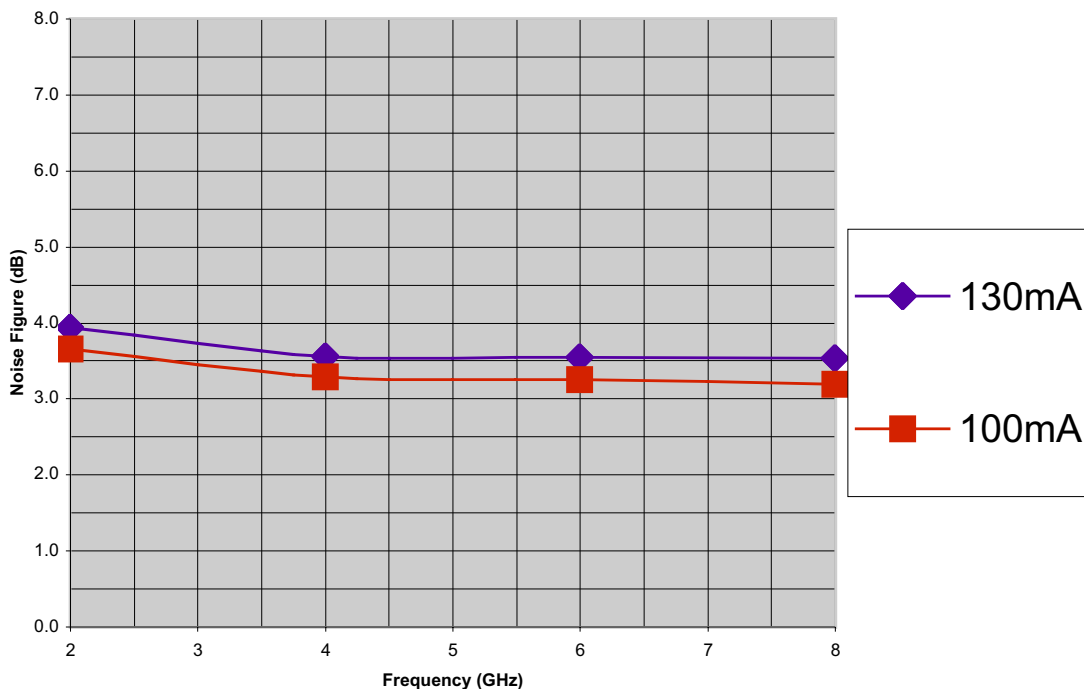

CMM1200 Typical Power Data
Connectorized Fixture; 5V, 100mA

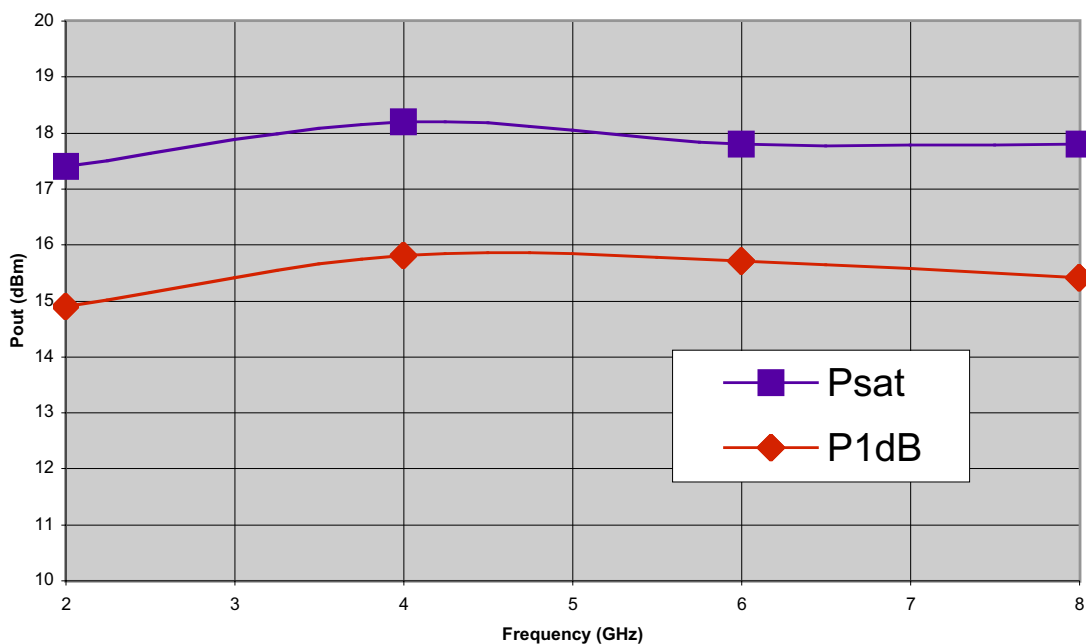



Assembly Example

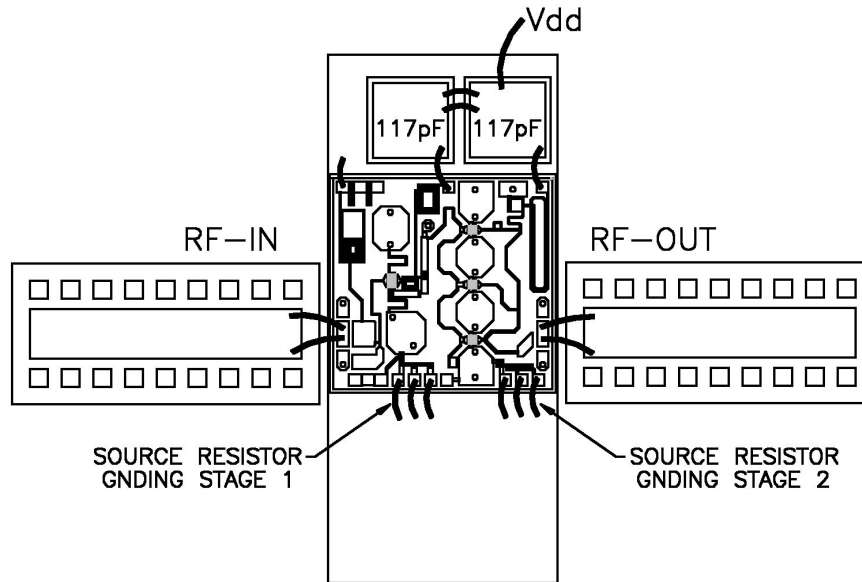

Ordering Information

The CMM1200-BD is available in bare die and is shipped in Gel Pak.

Part Number for Ordering
CMM1200-BD

Package
Bare Die

Celeritek reserves the right to make changes without further notice to any products herein. Celeritek makes no warranty, representation or guarantee regarding the suitability of its products for any particular purpose, nor does Celeritek assume any liability arising out of the application or use of any product or circuit, and specifically disclaims any and all liability, including without limitation consequential or incidental damages. "Typical" parameters can and do vary in different applications. All operating parameters, including "Typicals" must be validated for each customer application by customer's technical experts. Celeritek does not convey any license under its patent rights nor the rights of others. Celeritek products are not designed, intended, or authorized for use as components in systems intended for surgical implant into the body, or other applications intended to support or sustain life, or for any other application in which the failure of the Celeritek product could create a situation where personal injury or death may occur. Should Buyer purchase or use Celeritek products for any such unintended or unauthorized application, Buyer shall indemnify and hold Celeritek and its officers, employees, subsidiaries, affiliates, and distributors harmless against all claims, costs, damages, and expenses, and reasonable attorney fees arising out of, directly or indirectly, any claim of personal injury or death associated with such unintended or unauthorized use, even if such claim alleges that Celeritek was negligent regarding the design or manufacture of the part. Celeritek is a registered trademark of Celeritek, Inc. Celeritek, Inc. is an Equal Opportunity/Affirmative Action Employer.