

3-INPUT 1OUTPUT 3ch VIDEO AMPLIFIER WITH LPF

■ GENERAL DESCRIPTION

NJM2515 is the 3 input 1 output 3ch video amplifier. Internal LPF is progressive correspondence. Also the High Definition (30MHz) is realized by LPF through mode. It is the best for the video system corresponding to a component video signal or a RGB signal.

■ PACKAGE OUTLINE



NJM2515V

■ FEATURES

- Operating voltage 4.5 to 5.5V
- Internal 3ch 3-input 1-output video switch
- Internal LPF 0dBtyp.at 13.5MHz
- Internal LPF through switch 0dBtyp.at 34MHz
- Internal 6dB amplifier and 75ohm driver
- Internal Power Save circuit
- Bipolar technology
- Package outline SSOP32

■ PIN CONFIGURATION

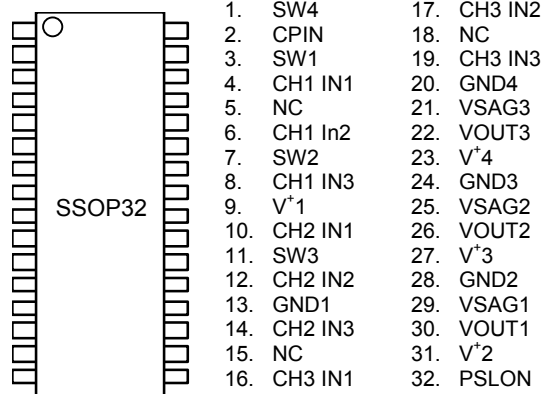

■ BLOCK DIAGRAM

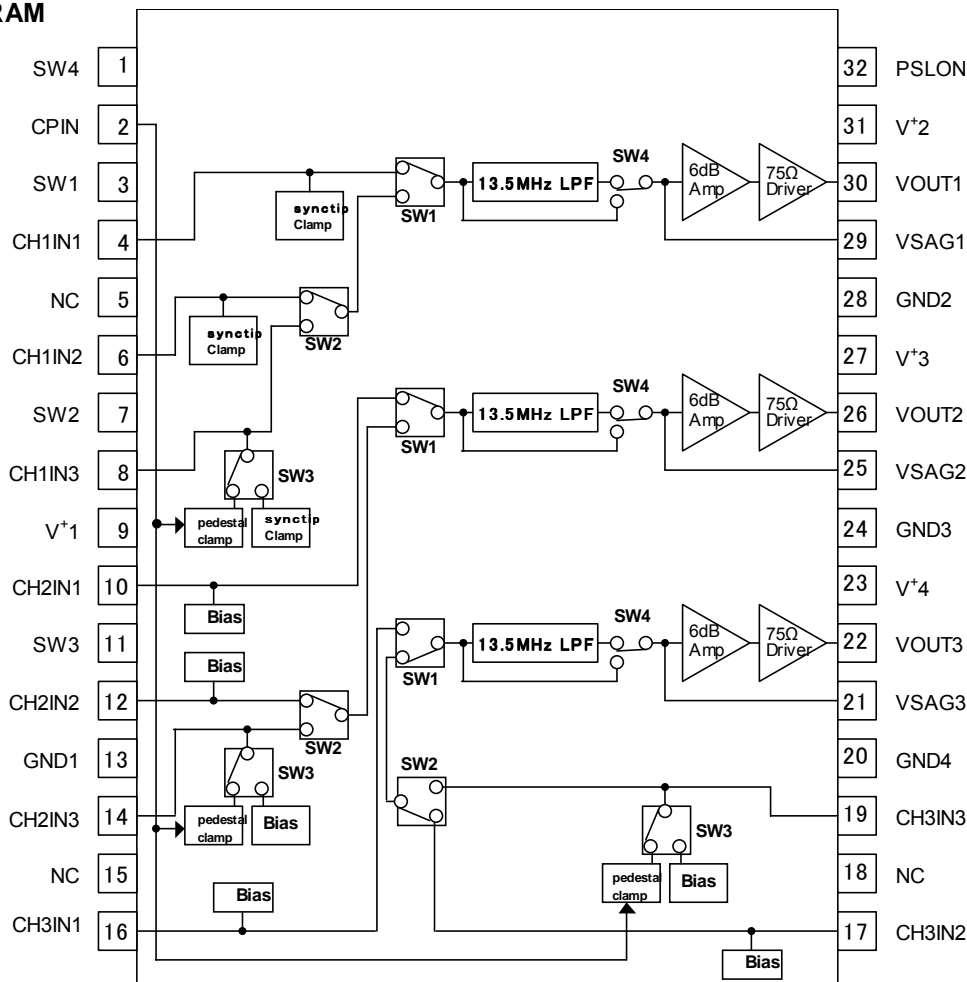

■ ABSOLUTE MAXIMUM RATINGS (Ta=25°C)

PARAMETER	SYMBOL	RATINGS	UNIT
Supply Voltage	V ⁺	10.0	V
Power Dissipation	P _D	1250*	mW
Operating Temperature Range	T _{opr}	-40 to +85	°C
Storage Temperature Range	T _{str}	-40 to +150	°C

*EIA/JEDEC STANDARD Test Board (76.2x114.3x1.6mm,4layers,FR-2)mounting

■ RECOMMENDED OPERATING CONDITION(Ta=25°C)

PARAMETER	SYMBOL	TEST CONDITION	MIN.	TYP.	MAX.	UNIT
Operating Voltage	V _{opr}		4.5	5.0	5.5	V

■ ELECTRICAL CHARACTERISTICS (V⁺1= V⁺2= V⁺3= V⁺4=5V, RL=150ohm, Ta=25°C)

PARAMETER	SYMBOL	TEST CONDITION	MIN.	TYP.	MAX.	UNIT
Supply Current	I _{CC}	V ⁺ 1 to V ⁺ 4, No signal	-	27	40	mA
Supply Current with Power Save Mode	I _{save}	V ⁺ 1 to V ⁺ 4, No signal, Power save mode	-	0.6	1.3	mA
Maximum Output Level 1	V _{omy}	V _{in} =100kHz sin-signal, THD=1% Select to sync-chip clamp	2.4	2.5	-	V _{p-p}
Maximum Output Level 2	V _{om PbPr}	V _{in} =100kHz sin-signal, THD=1% Select to bias	2.4	2.5	-	V _{p-p}
Maximum Output Level 3	V _{om RGB}	V _{in} =100kHz sin-signal, THD=1% Select to pedestal clamp	1.8	1.9	-	V _{p-p}
Voltage Gain	G _v	V _{in} =1MHz, 1.0V _{p-p} sin-signal	6.0	6.4	6.8	dB
Voltage Gain Difference between Input Terminal	ΔG _{vI}	V _{in} =1MHz, 1.0V _{p-p} sin-signal, IN1 to IN2 to IN3 for all channel	-0.2	0	0.2	dB
Voltage Gain Difference between Channel	ΔG _{vB}	V _{in} =1MHz, 1.0V _{p-p} sin-signal, CH1 to CH2 to CH3	-0.2	0	0.2	dB
LPF Characteristics 1	G _{f13.5M}	13.5MHz/1MHz, 1.0V _{p-p} sin-signal	-3.0	0	1.0	dB
LPF Characteristics 2	G _{f54M}	54MHz/1MHz, 1.0V _{p-p} sin-signal	-	-40	-	dB
Frequency Characteristics	G _f	V _{in} =34MHz/1MHz, 1.0V _{p-p} sin-signal, select to LPF through mode	-	0	-	dB
Crosstalk between Input Terminal 1	CT-I1	V _{in} =4.43MHz, 1.0V _{p-p} sin-signal, IN1 to IN2 to IN3 for all channel	-	-70	-	dB
Crosstalk between Input Terminal 2	CT-I2	V _{in} =30MHz, 1.0V _{p-p} sin-signal, IN1 to IN2 to IN3 for all channel	-	-50	-	dB
Crosstalk between Channel 1	CT-B1	V _{in} =4.43MHz, 1.0V _{p-p} sin-signal, CH1 to CH2 to CH3	-	-70	-	dB
Crosstalk between Channel 2	CT-B2	V _{in} =30MHz, 1.0V _{p-p} sin-signal, CH1 to CH2 to CH3	-	-50	-	dB
Differential Gain	DG	V _{in} =1.0V _{p-p} , 10step video signal	-	0.5	-	%
Differential Phase	DP	V _{in} =1.0V _{p-p} , 10step video signal	-	0.3	-	deg
S/N Ratio	SN	V _{in} =1.0V _{p-p} , 100% white video signal, 100KHz to 6MHz	-	70	-	dB

■ ELECTRICAL CHARACTERISTICS ($V^+1 = V^+2 = V^+3 = V^+4 = 5V$, $R_L = 150\Omega$, $T_a = 25^\circ C$)

PARAMETER	SYMBOL	TEST CONDITION	MIN.	TYP.	MAX.	UNIT
Switch High level for power save	VthPH	PS	2.0	-	V ⁺	V
Switch Low level for power save	VthPL	PS	0	-	0.6	V
Switch High level for input signal switch	VthSH	SW1, SW2	2.0	-	V ⁺	V
Switch High level for input signal switch	VthSL	SW1, SW2	0	-	0.6	V
High level for CP IN	Vth CPH		2.0	-	V ⁺	V
Low level for CP IN	Vth CPL		0	-	0.6	V

■ CONTROL SIGNAL

TERMINAL	CONTROL	NOTE
PS	H	Power save: OFF (Operation)
	L	Power save: ON (Mute)
	OPEN	Power save: ON (Mute)

TERMINAL	CONTROL		NOTE
SW 1, SW2	SW1	SW2	
	L, OPEN	X	IN1 (X=don't care)
	H	L, OPEN	IN2
	H	H	IN3

TERMINAL	CONTROL	NOTE
SW 3	H	Y, Pb, Pr (CH1IN3: Sync Tip Clamp CH2IN3/CH3IN3: Bias)
	L	RGB (CH1IN3/CH2IN3/CH3IN3: Pedestal Clamp)
	OPEN	RGB (CH1IN3/CH2IN3/CH3IN3: Pedestal Clamp)

TERMINAL	CONTROL	NOTE
SW4	H	LPF
	L	Through
	OPEN	Through

NJM2515

www.DataSheet4U.com

■ TEST CIRCUIT

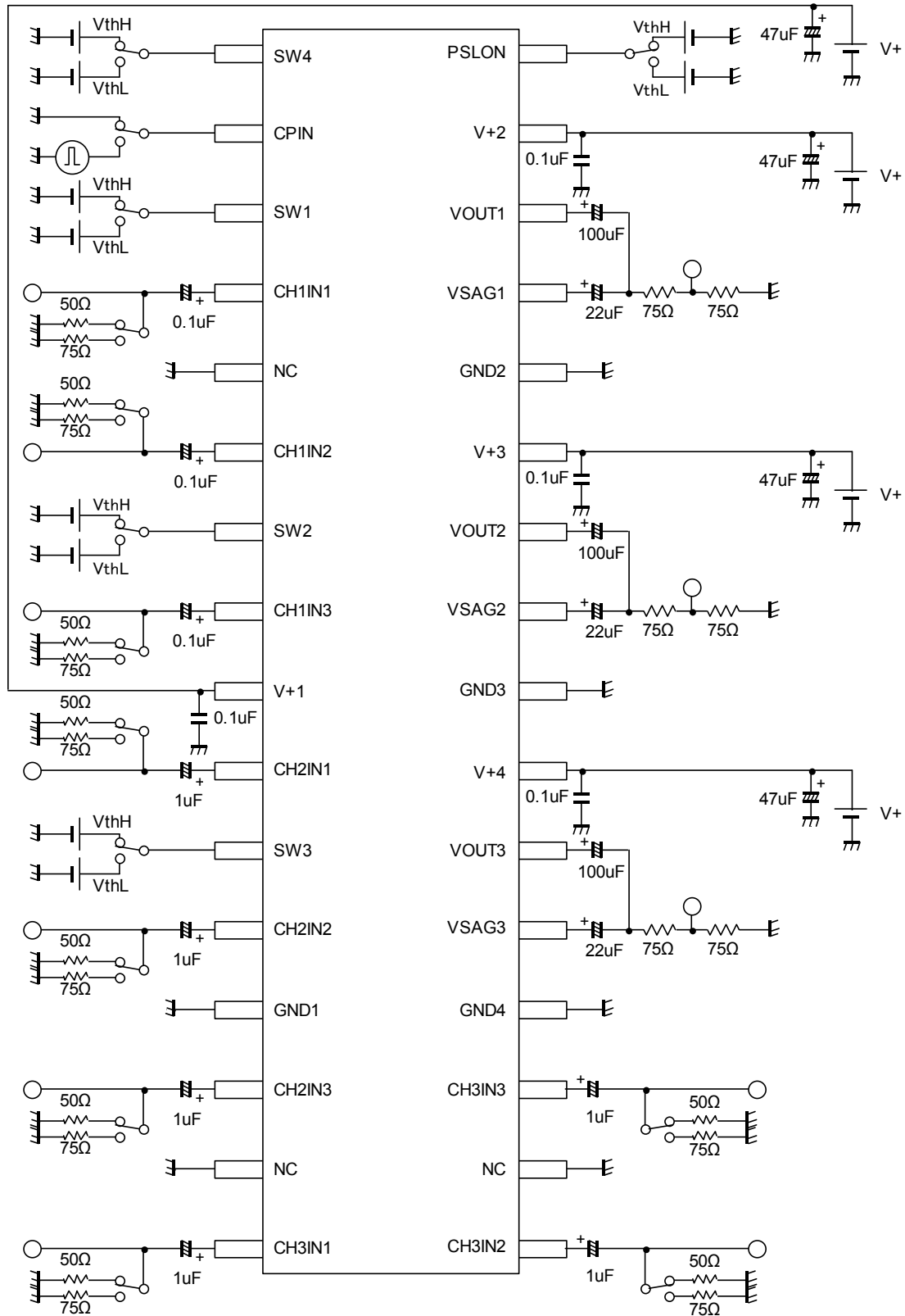

■ APPLICATION

Select of a pedestal-clamp (SW3: L, OPEN) set up a RGB signal input.

Please input a clamp pulse to the timing, which synchronized with the input signal. Please input a clamp pulse in the back porch.

Select of sync- tip-clamp (SW3: H) set up a COMPONENT signal input.

Please do not input a clamp pulse, when a component signal and a clamp pulse are asynchronous.

Refer to the following.

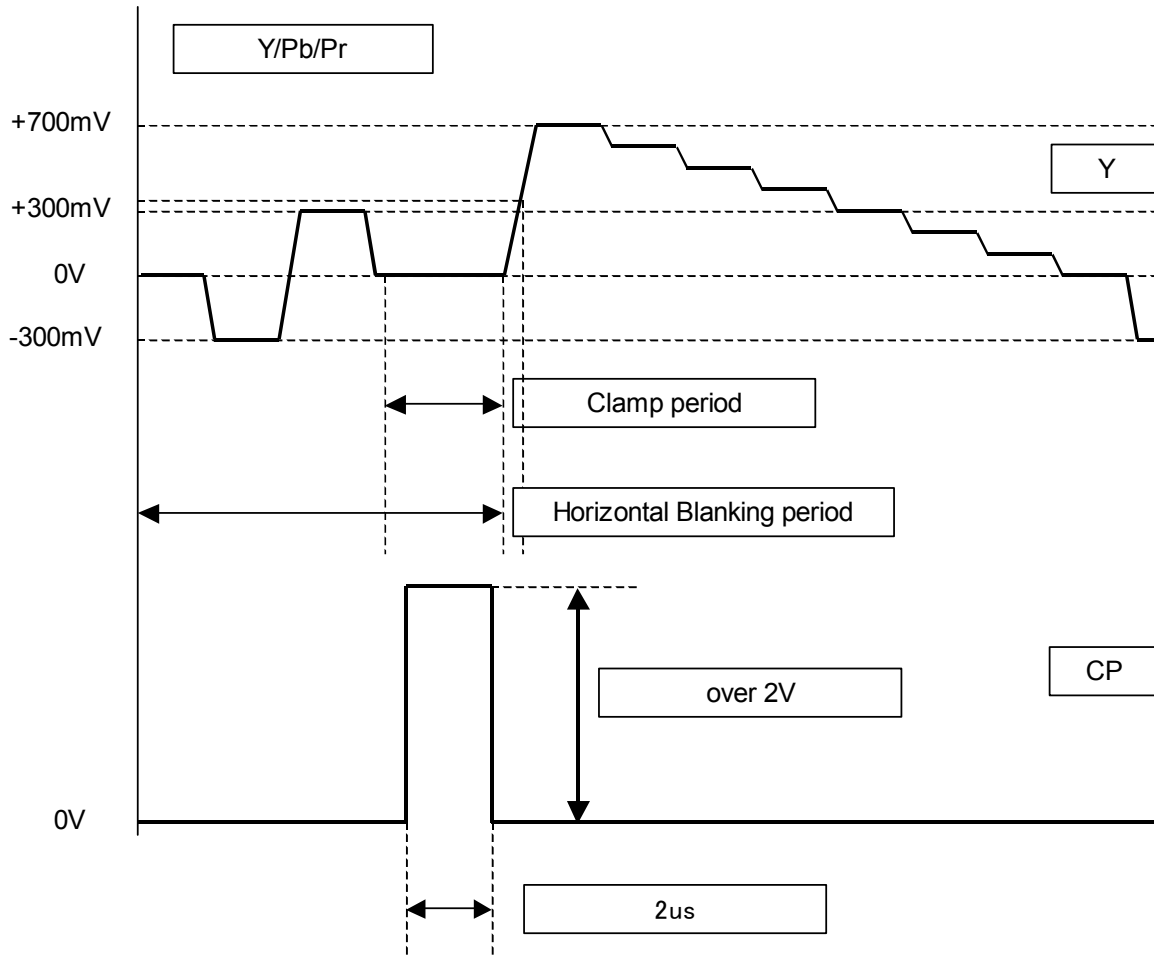

[CAUTION]

The specifications on this databook are only given for information, without any guarantee as regards either mistakes or omissions. The application circuits in this databook are described only to show representative usages of the product and not intended for the guarantee or permission of any right including the industrial rights.