

# BYY57A / BYY58A

## 50A Silicon Power Rectifier Diode

### Description

The BYY57A/58A are hermetically sealed 50A-diodes, which are available in different reverse voltage classes up to 800V.

The diodes can be delivered with limited forward voltage and reverse current differences for parallel connecting in rectifier stacks and back-off-diodes

### Features

- Forward current 50A
- Reverse voltage 75V – 800V
- Hermetic press-fit package
- Available in different modifications of the package

### Applications

- Power supplies
- Rectifier diode in car generators
- Rectifier bridges/stacks
- Back-off-diodes

### Pinout details



BYY57A: 1 – cathode; 2 - anode

BYY58A: 1 – anode; 2 - cathode

### Typical application circuit

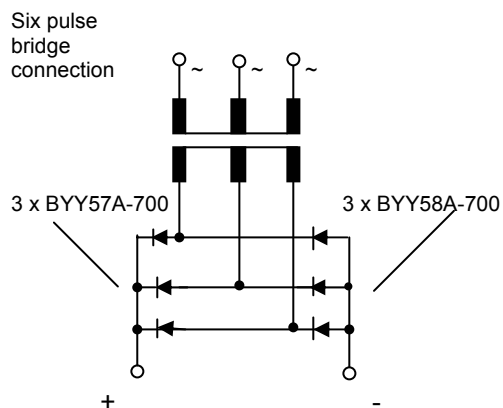

### Ordering information

Device	Quantity per box	Options
BYY57A-75; ...; BYY57A-800	500	The package quantities for the different package modifications are included in "PressFitPackageModifications.pdf"
BYY58A-75; ...; BYY58A-800	500	

### Device marking

Devices are identified by type. Colour of marking: BYY57A- black, BYY58A – red

422.....	date code 422 = 2004 week 22
ZETEX	
BYY57.....	diode type
A400.....	50A diode / repetitive peak reverse voltage $V_{RRM}$ (in V) 400

# BYY57A / BYY58A

**Absolute maximum ratings** (at  $T_{amb} = 25^{\circ}\text{C}$  unless otherwise stated)

Parameter		Symbol		Unit	Test condition	
Repetitive peak reverse voltage	BYY57A-75	BYY58A-75	$V_{RRM}$	75	V	$T_c = 150^{\circ}\text{C}$
	BYY57A-100	BYY58A-100		100		
	BYY57A-150	BYY58A-150		150		
	BYY57A-200	BYY58A-200		200		
	BYY57A-300	BYY58A-300		300		
	BYY57A-400	BYY58A-400		400		
	BYY57A-500	BYY58A-500		500		
	BYY57A-600	BYY58A-600		600		
	BYY57A-700	BYY58A-700		700		
	BYY57A-800	BYY58A-800		800		
Forward current, arithmetic value		$I_{FAV}$		50	A	
Surge forward current		$I_{FSM}$		900	A	half-sine wave, $\leq 10$ ms
				800		$T_J = 175^{\circ}\text{C}$ half-sine wave, $\leq 10$ ms
Maximum rated value		$\int i^2 dt$		4050	$\text{A}^2\text{s}$	half-sine wave, $\leq 10$ ms
				3200		$T_J = 175^{\circ}\text{C}$ half-sine wave, $\leq 10$ ms
Repetitive peak forward current		$I_{FRM} = \pi * I_{FAV}$		157	A	$f = >15$ Hz
Effective forward current		$I_{FRMS}$		78	A	
Junction temperature		$T_{Jmax}$		200	$^{\circ}\text{C}$	
Storage temperature range		$T_{stg}$		- 50 to + 175	$^{\circ}\text{C}$	

## Thermal resistance

Parameter	Symbol	Value	Unit
Junction to case	$R_{\theta JC}$	0.8	$^{\circ}\text{C}/\text{W}$

## Thermal characteristics

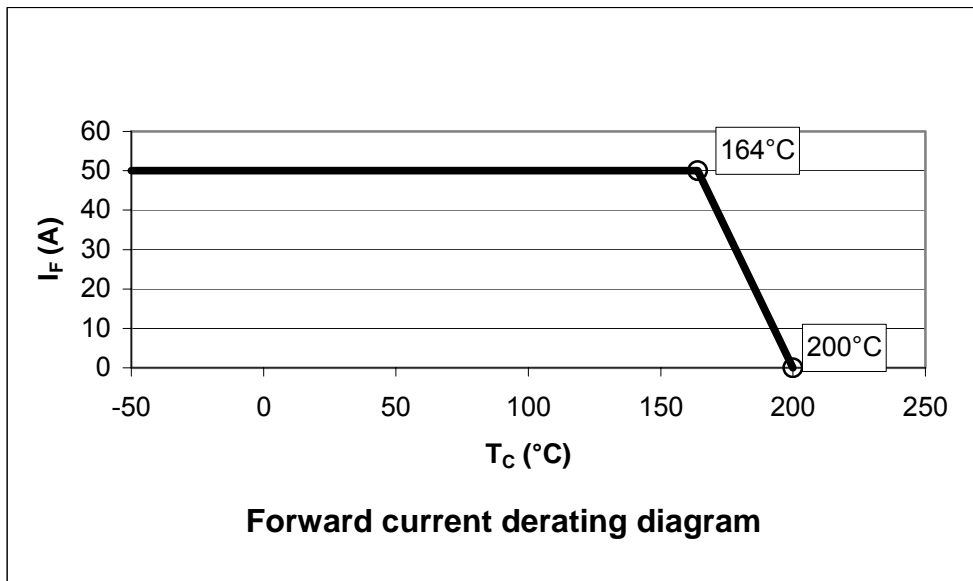

## Electrical characteristics (at $T_{\text{amb}} = 25^{\circ}\text{C}$ unless otherwise stated)

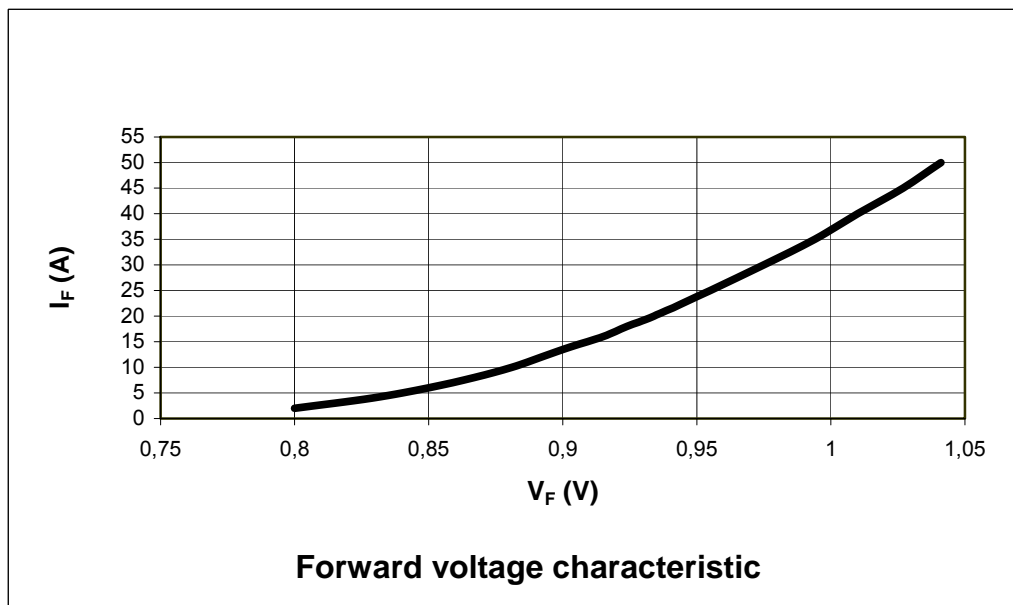

# BYY57A / BYY58A

## Electrical characteristics (at $T_{amb} = 25^{\circ}\text{C}$ unless otherwise stated)

Parameter		Symbol	Min.	Typ.	Max.	Unit	Test conditions
Forward voltage	BYY57A-75...800 BYY58A-75...800	$V_F$	-	1.05	1.15	V	$I_F = 50\text{ A}$ , measuring time 10ms (half-sine wave)
Forward voltage (information values)	BYY57A-75...800 BYY58A-75...800	$V_F$	-	0.810	-	V	$I_F = 20\text{ A}$ , measuring time 10ms (half-sine wave), $T_J = 150^{\circ}$
	BYY57A-75...800 BYY58A-75...800	$V_F$	-	-	1.2	V	$I_F = 75\text{ A}$
Reverse current	BYY57A-75...150 BYY58A-75...150	$I_{RRM}$	-	-	3	mA	$T_J = 150^{\circ}\text{C}$ , at $V_{RRM}$
	BYY57A-200...800 BYY58A-200...800		-	-	1.5		
	BYY57A-75...400 BYY58A-75...400	$I_{RRM}$	-	-	0.25	mA	at $V_{RRM}$
	BYY57A-500...800 BYY58A-500...800		-	-	0.1		
Threshold voltage (information value)		$V_{(FO)}$	-	0.66	-	V	$T_J = 175^{\circ}\text{C}$
Slope resistance (information value)		$r_F$	-	4.5	-	m $\Omega$	$T_J = 175^{\circ}\text{C}$

## Options: Electrical characteristics for parallel connecting

(at  $T_{amb} = 25^{\circ}\text{C}$  unless otherwise stated)

Option	Parameter	Symbol	Min.	Typ.	Max.	Unit	Test conditions
1	Forward voltage difference in one category of forward voltage	$\Delta V_F$	-	-	0.05	V	$I_F = 50\text{ A}$ , measuring time 10ms (half-sine wave)
2	Reverse current in one category of forward voltage (only for BYY57A-300...800 and BYY58A-300...800)	$I_R$	-	-	0.01	mA	at $V_{RRM}$

## Packaging details

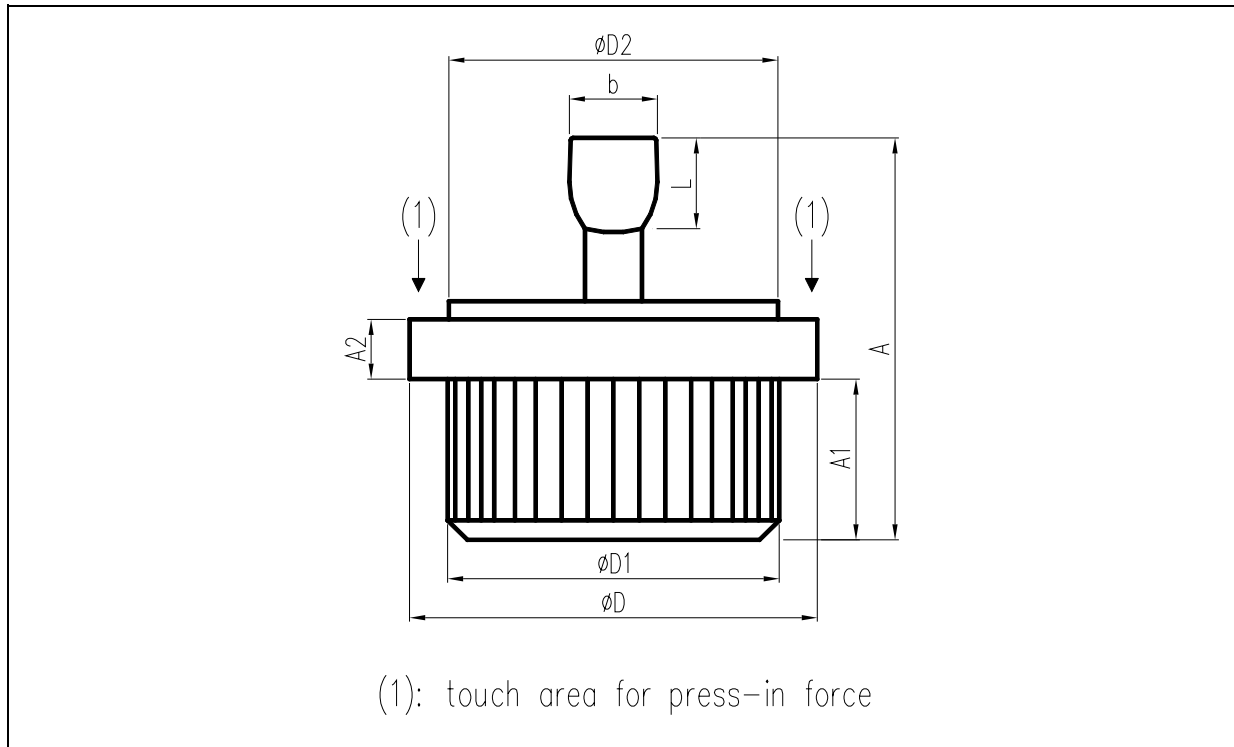

## Package dimensions

Dimensions in millimeters are control dimensions, dimensions in inches are approximate

DIM	Millimeters			Inches		
	MIN	TYP	MAX	MIN	TYP	MAX
A	15,00	15,50	16,00	0,591	0,610	0,630
A1	5,90	6,10	6,30	0,232	0,240	0,248
A2	2,10	2,30	2,50	0,083	0,091	0,098
b	3,50	3,80	4,10	0,138	0,150	0,161
D	15,50	15,70	15,90	0,610	0,618	0,626
D1	12,75	12,80	12,85	0,502	0,504	0,506
D2	12,30	12,50	12,70	0,484	0,492	0,500
L	3,00	3,50	4,00	0,118	0,138	0,157

Europe	Americas	Asia Pacific	Corporate Headquarters
Zetex GmbH Streitfeldstraße 19 D-81673 München Germany	Zetex Inc 700 Veterans Memorial Highway Hauppauge, NY 11788 USA	Zetex (Asia Ltd) 3701-04 Metroplaza Tower 1 Hing Fong Road, Kwai Fong Hong Kong	Zetex Semiconductors plc Zetex Technology Park, Chadderton Oldham, OL9 9LL United Kingdom
Telefon: (49) 89 45 49 49 0 Fax: (49) 89 45 49 49 49 europe.sales@zetex.com	Telephone: (1) 631 360 2222 Fax: (1) 631 360 8222 usa.sales@zetex.com	Telephone: (852) 26100 611 Fax: (852) 24250 494 asia.sales@zetex.com	Telephone (44) 161 622 4444 Fax: (44) 161 622 4446 hq@zetex.com

For international sales offices visit [www.zetex.com/offices](http://www.zetex.com/offices)

Zetex products are distributed worldwide. For details, see [www.zetex.com/salesnetwork](http://www.zetex.com/salesnetwork)

This publication is issued to provide outline information only which (unless agreed by the company in writing) may not be used, applied or reproduced for any purpose or form part of any order or contact or be regarded as a representation relating to the products or services concerned. The company reserves the right to alter without notice the specification, design, price or conditions of supply of any product or service.