

Compact high speed thick film thermal printhead (12 dots / mm)

KF3004-GD31A

Using its expertise in LSI technology, ROHM has developed new high density driver chips for use in the KF3004-GD31A. Capable of being employed for both thermal and thermal transfer printing, with a print speed of 200mm/s, the resulting print heads are the fastest in their class. The high-speed and high-density printing answers the needs of ATM, kiosk and ticket printing devices, which are increasingly being called upon to produce graphical output.

●Applications

Label printers
Ticket printers
Terminal printers

●Features

- 1) The use of a special partial glaze and the latest heating element structure, along with new high-density driver chips that can accept big current, has allowed ROHM to achieve print speeds of 200mm/s with using thermal history control, the fastest in its class.
- 2) One rank resistance value of $1250\Omega \pm 3\%$ eliminates the inconvenience of rank selection.
- 3) 2-inch, 3-inch and 4-inch series are available.

●External dimensions (Units : mm)

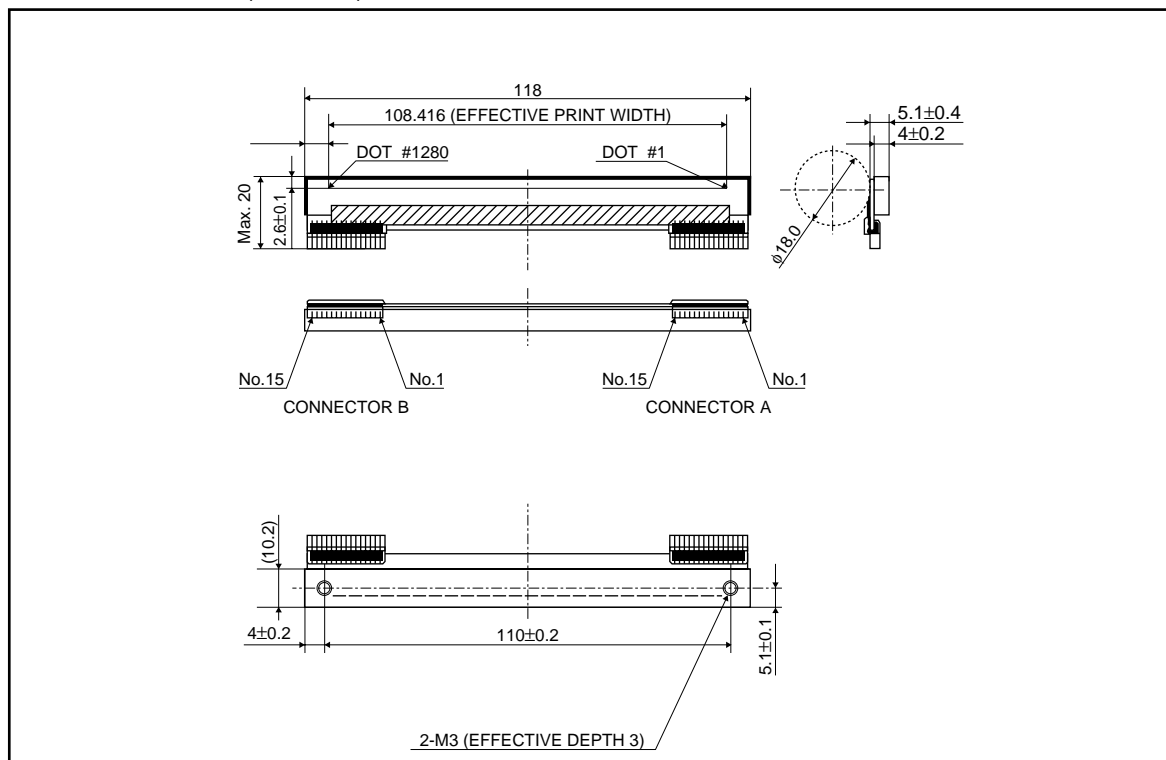

Printheads

●Equivalent circuit

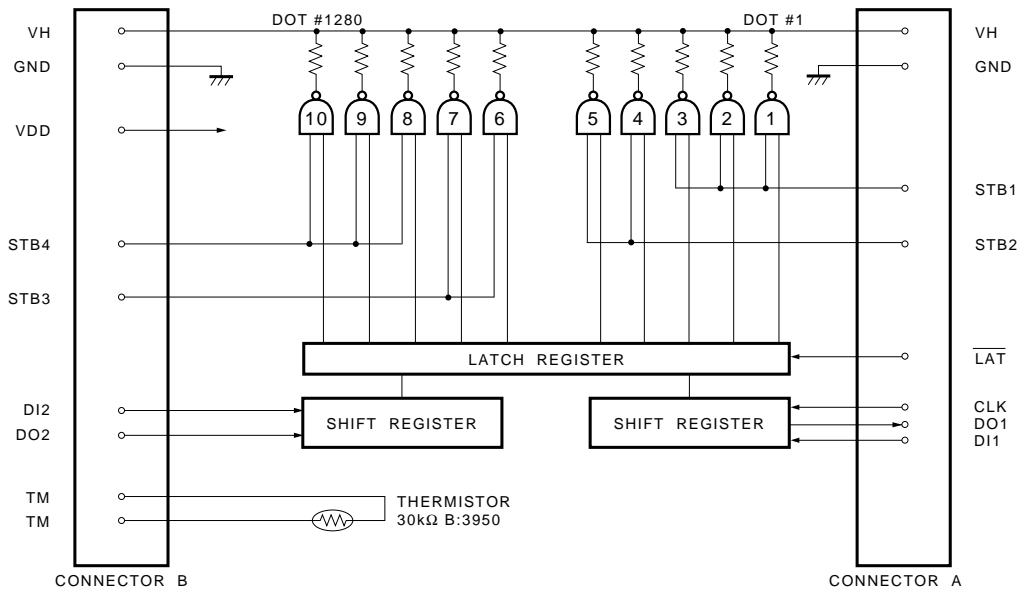

STB No.	Dot No.	dots / STB
1	1 ~ 384	384
2	385 ~ 640	256
3	641 ~ 896	256
4	897 ~ 1280	384

DI No.	Dot No.	dots / STB
1	1 ~ 640	640
2	640 ~ 1280	640

Fig.1

Printheads

●Pin assignments

CONNECTOR B	
No.	Circuit
1	GND
2	GND
3	GND
4	GND
5	STB3
6	STB4
7	V _{DD}
8	TM
9	TM
10	DO2
11	DI2
12	VH
13	VH
14	VH
15	VH

CONNECTOR A	
No.	Circuit
1	VH
2	VH
3	VH
4	VH
5	DI1
6	DO1
7	$\overline{\text{LAT}}$
8	CLK
9	STB1
10	STB2
11	GND
12	GND
13	GND
14	GND
15	GND

●Timing chart

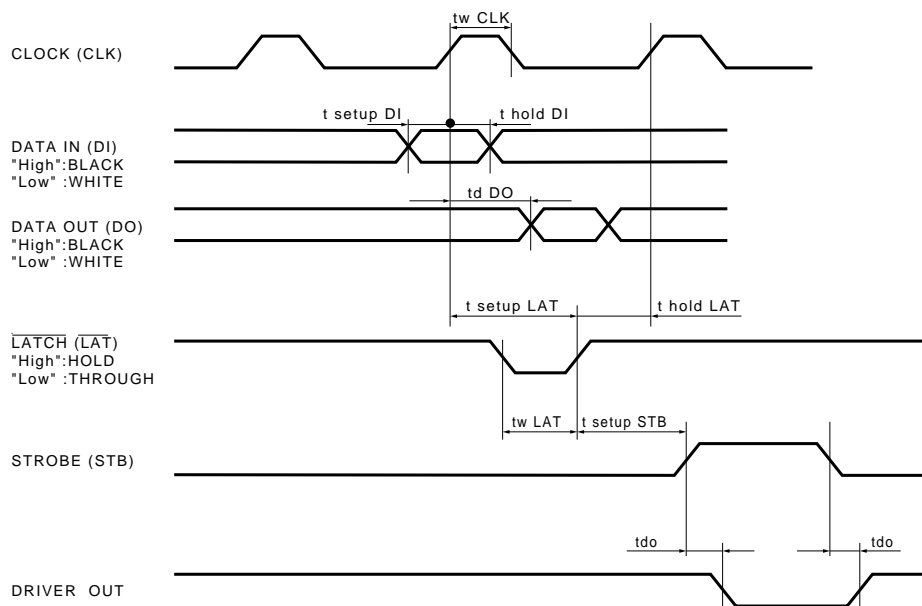

Fig.2

Printheads

●Characteristics

Parameter	Symbol	Typical	Unit
Effective printing width	–	108.416	mm
Dot pitch	–	0.0847	mm
Total dot number	–	1280	dots
Average resistance value	Rave	1250	Ω
Applied voltage	V _H	24	V
Applied power	P _O	0.40	W/dot
Print cycle	SLT	0.83	ms
Pulse width	T _{ON}	0.324	ms
Maximum number of dots energized simultaneously	–	640	dots
Maximum clock frequency	–	8	MHz
Maximum roller diameter	–	φ18.0	mm
Running life / pulse life	–	50/5×10 ⁷	km/pulses
Operating temperature	–	5~45	°C

●Electrical characteristic curves

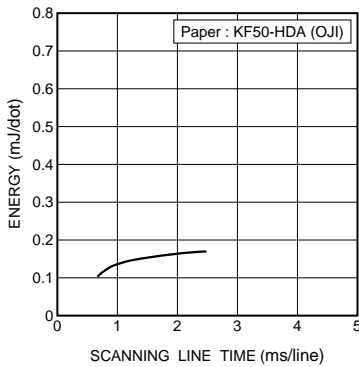

Fig.3 Adaptive speed chart

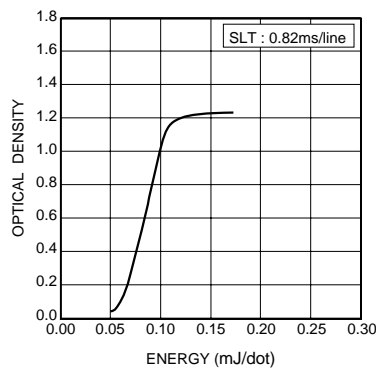

Fig.4 Representative density curve

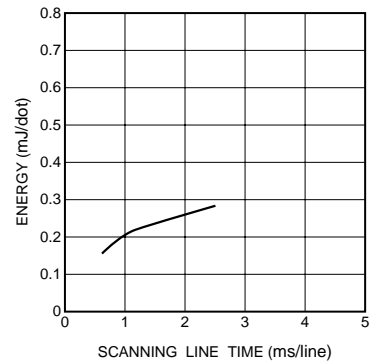

Fig.5 Maximum energy curve

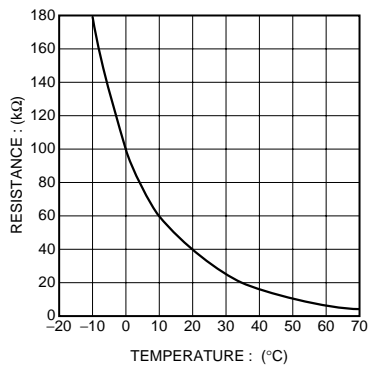

Fig.6 Thermistor curve