

RF & MICROWAVE TRANSISTORS AVIONICS APPLICATIONS

- REFRACTORY/GOLD METALLIZATION
- EMITTER SITE BALLASTED
- ∞:1 VSWR CAPABILITY
- LOW THERMAL RESISTANCE
- INPUT MATCHING
- METAL/CERAMIC HERMETIC PACKAGE
- P_{OUT} = 15 W MIN. WITH 8.1 dB GAIN
- BANDWIDTH 255 MHz

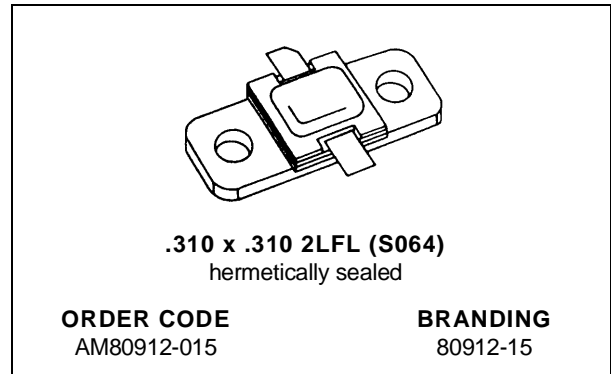

DESCRIPTION

The AM80912-015 is designed for specialized avionics applications, including JTIDS, where power is provided under pulse formats utilizing short pulse widths and high burst or overall duty cycles.

The AM80912-015 is housed in the unique IMPAC™ Hermetic Metal/Ceramic package with

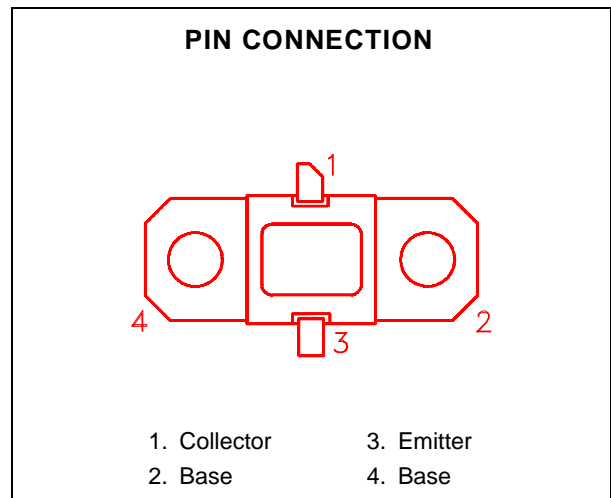

ABSOLUTE MAXIMUM RATINGS (T_{case} = 25°C)

Symbol	Parameter	Value	Unit
P _{DISS}	Power Dissipation*(T _C ≤ 100°C)	50	W
I _C	Device Current*	1.8	A
V _{CC}	Collector-Supply Voltage*	32	V
T _J	Junction Temperature (Pulsed RF Operation)	250	°C
T _{STG}	Storage Temperature	- 65 to +200	°C

THERMAL DATA

R _{TH(j-c)}	Junction-Case Thermal Resistance*	3.0	°C/W
----------------------	-----------------------------------	-----	------

*Applies only to rated RF amplifier operation

ELECTRICAL SPECIFICATIONS ($T_{case} = 25^{\circ}C$)

STATIC

Symbol	Test Conditions		Value			Unit
			Min.	Typ.	Max.	
BV _{CBO}	I _C = 10mA	I _E = 0mA	55	—	—	V
BV _{EBO}	I _E = 1mA	I _C = 0mA	3.5	—	—	V
BV _{CER}	I _C = 10mA	R _{BE} = 10Ω	55	—	—	V
I _{CES}	V _{BE} = 0V	V _{CE} = 28V	—	—	2.0	mA
h _{FE}	V _{CE} = 5V	I _C = 500mA	15	—	150	—

DYNAMIC

Symbol	Test Conditions			Value			Unit
				Min.	Typ.	Max.	
P _{OUT}	f = 960 — 1215MHz	P _{IN} = 2.3W	V _{CC} = 28V	15	17	—	W
η _C	f = 960 — 1215MHz	P _{IN} = 2.3W	V _{CC} = 28V	45	49	—	%
G _P	f = 960 — 1215MHz	P _{IN} = 2.3W	V _{CC} = 28V	8.1	8.9	—	dB

Note: Pulse format: 6.4 μS on 6.6 μS off, repeat for 3.3 ms, then off for 4.5125 ms.
Duty Cycle: Burst 49.2%, overall 20.8%

TYPICAL PERFORMANCE

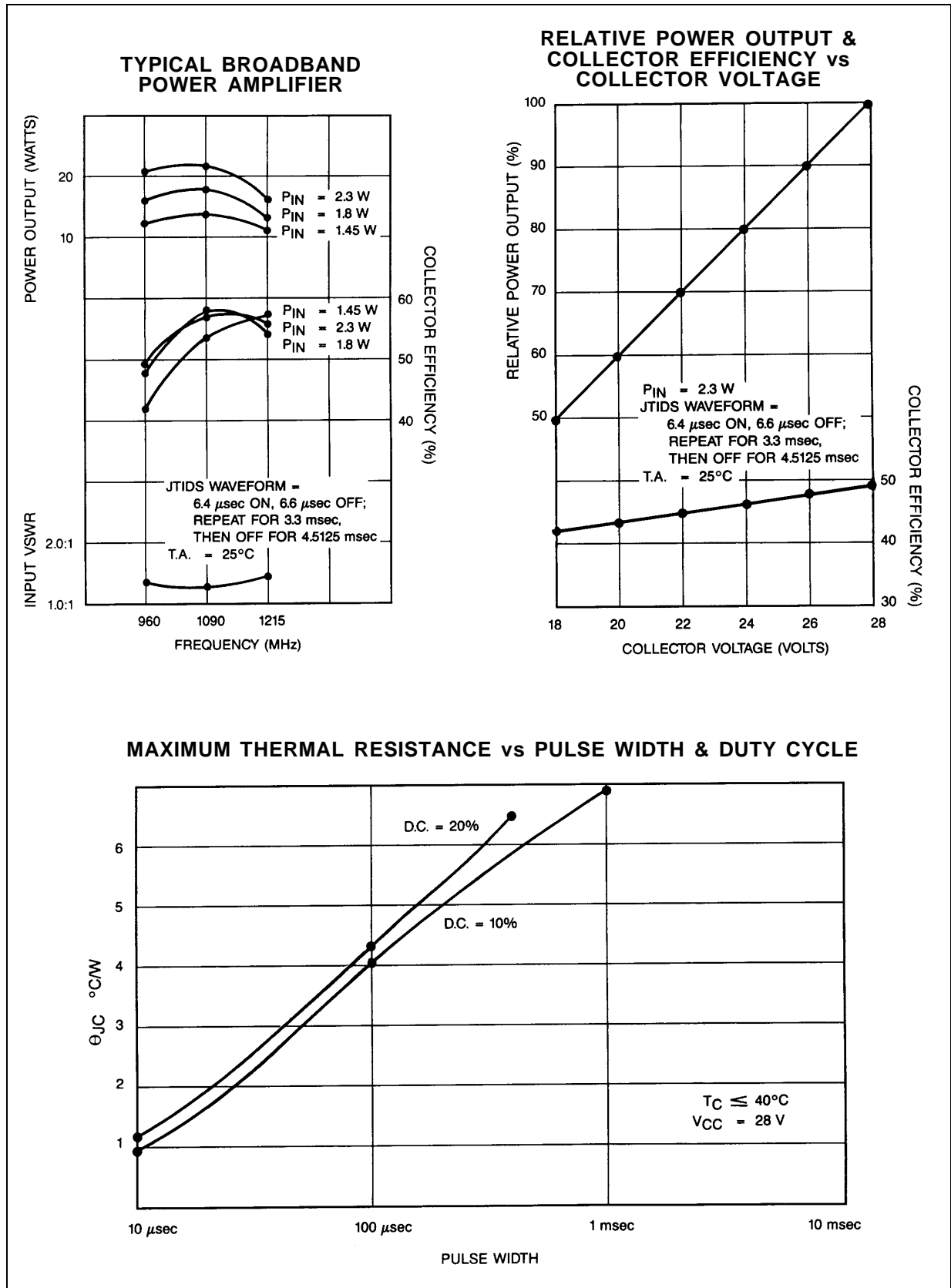

IMPEDANCE DATA

TYPICAL INPUT IMPEDANCE

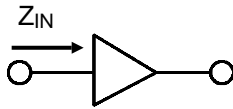

$P_{IN} = 2.3 \text{ W}$
 $V_{CC} = 28 \text{ V}$
 $Z_{O^*} = 50 \text{ ohms}$

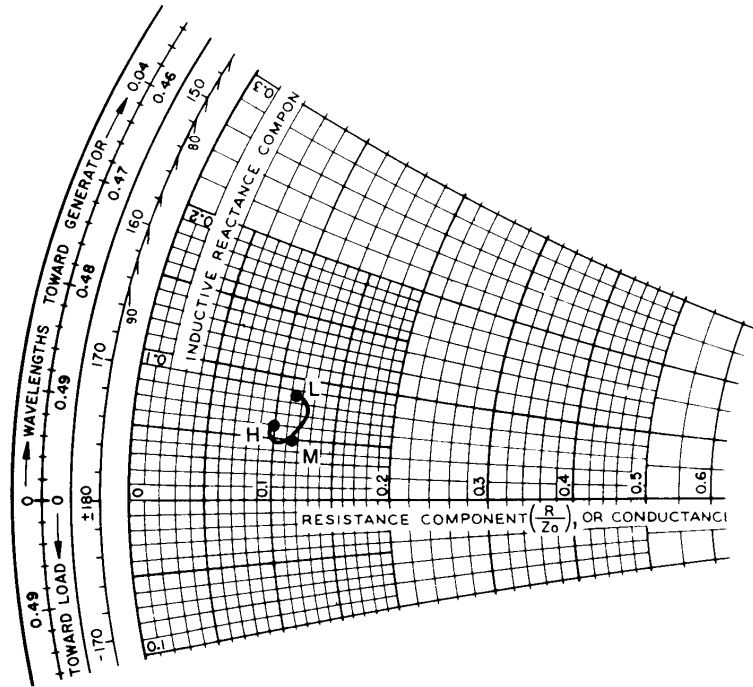

FREQ.	$Z_{IN} (\Omega)$	$Z_{CL} (\Omega)$
L = 960 MHz	$5.7 + j 4.3$	$5.7 + j 7.7$
M = 1090 MHz	$5.8 + j 2.5$	$4.3 + j 6.5$
H = 1215 MHz	$5.0 + j 3.0$	$4.0 + j 4.8$

TYPICAL COLLECTOR LOAD IMPEDANCE

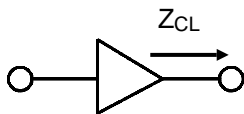

$P_{IN} = 2.3 \text{ W}$
 $V_{CC} = 28 \text{ V}$
 $Z_{O^*} = 50 \text{ ohms}$

*Normalized Impedance

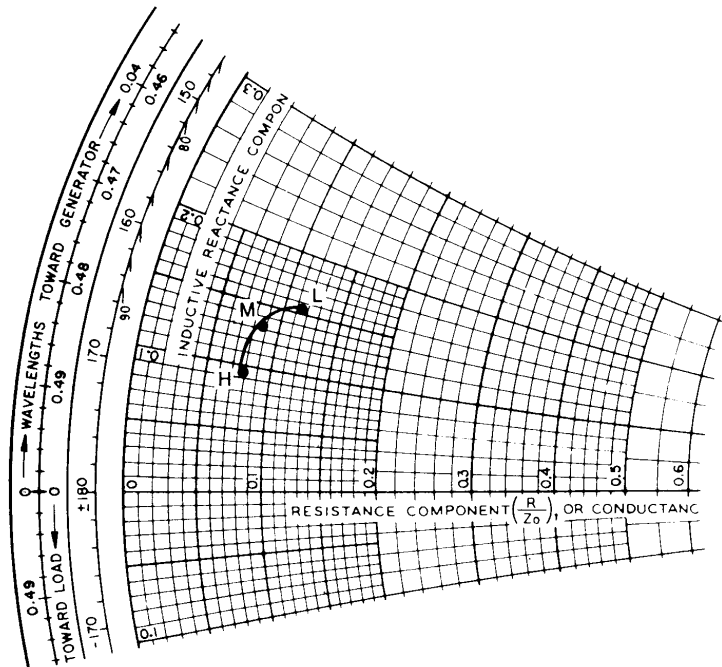

TEST CIRCUIT

Ref.: Dwg. No. 104-000284

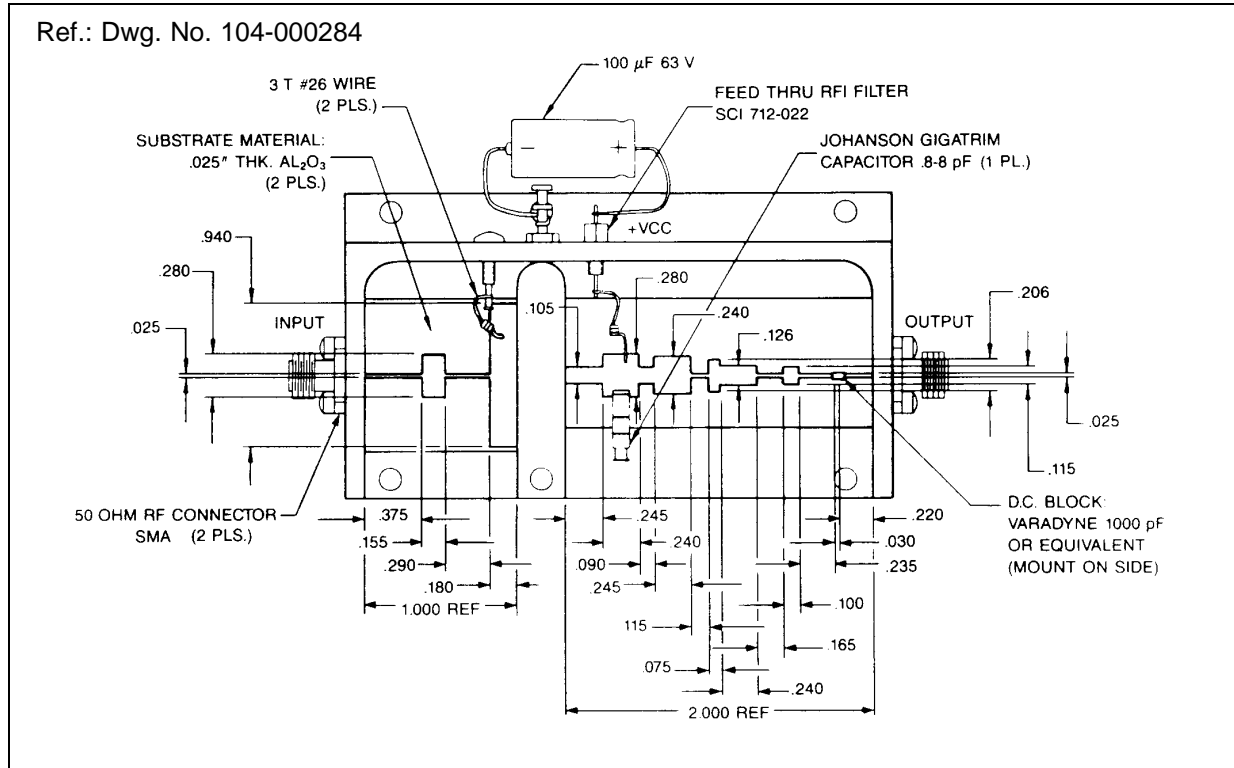

PACKAGE MECHANICAL DATA

Ref.: Dwg. No. 12-221

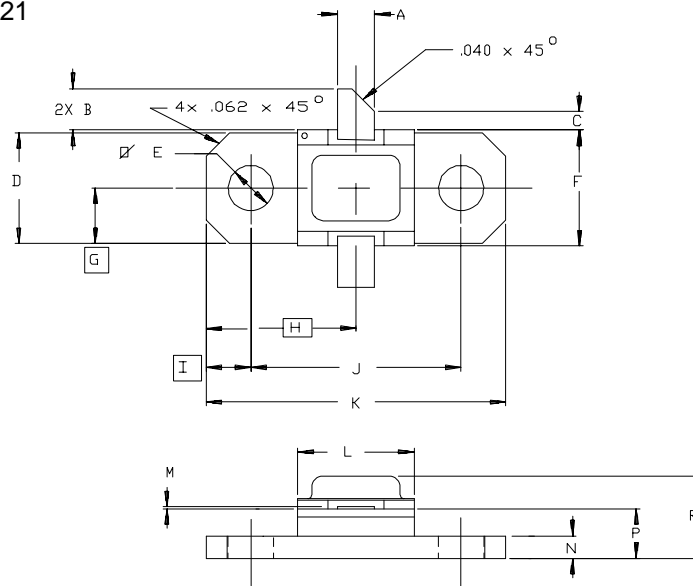

SGS-THOMSON MICROELECTRONICS			CONT'D		
	MINIMUM Inches/mm	MAXIMUM Inches/mm		MINIMUM Inches/mm	MAXIMUM Inches/mm
A	.095/2,41	.105/2,67	K	.790/20,07	.810/20,57
B	.100/2,54	.120/3,05	L	.300/7,62	.320/8,13
C	.050/1,27		M	.003/0,08	.006/0,15
D	.286/7,26	.306/7,77	N	.052/1,32	.072/1,83
E	.110/2,79	.130/3,30	P	.118/3,00	.131/3,33
F	.306/7,77	.318/8,08	R		.230/5,84
G	.148/3,76				
H	.400/10,16				
I	.119/3,02				
J	.552/14,02	.572/14,53			

Information furnished is believed to be accurate and reliable. However, SGS-THOMSON Microelectronics assumes no responsibility for the consequences of use of such information nor for any infringement of patents or other rights of third parties which may results from its use. No license is granted by implication or otherwise under any patent or patent rights of SGS-THOMSON Microelectronics. Specifications mentioned in this publication are subject to change without notice. This publication supersedes and replaces all information previously supplied. SGS-THOMSON Microelectronics products are not authorized for use as critical components in life support devices or systems without express written approval of SGS-THOMSON Microelectronics.

© 1994 SGS-THOMSON Microelectronics - All Rights Reserved

SGS-THOMSON Microelectronics GROUP OF COMPANIES
 Australia - Brazil - France - Germany - Hong Kong - Italy - Japan - Korea - Malaysia - Malta - Morocco - The Netherlands -
 Singapore - Spain - Sweden - Switzerland - Taiwan - Thailand - United Kingdom - U.S.A