

POWER MANAGEMENT

Description

The SC1460-3.3 is a versatile charge pump designed for use in battery operated power supply applications requiring up to 5mA. Output voltage is referenced to a fixed ratio of V_{IN} ($V_o = 1.32 \times V_{IN}$). It enables a simple low current boost circuit to be implemented without the costly inductors or capacitors associated with regular switching circuits. Features include internal MOSFETs, control circuitry and charge pump capacitor, requiring only two external capacitors for a total solution. With a very high operating frequency (8MHz free running at $2.5V_{IN}$ typically), the SC1460-3.3 does not require large input or output capacitors, and therefore uses very little board space. Two versions are available: the SC1460-3.3 produces a 3.3V output from 2.5V in, and the SC1460-5 produces a 5V output from 3.3V in. Both are supplied in the popular 3 lead, SOT-23 package.

Features

- ◆ Small size - SOT-23 package
- ◆ 4% voltage accuracy
- ◆ Typical 100uA quiescent current
- ◆ V_{OUT} referenced within $\pm 4\%$ of $1.32 \times V_{IN}$

Applications

- ◆ Handheld Power Supplies
- ◆ PDA Power Supplies
- ◆ Notebook Power Supplies
- ◆ Peripheral Card Supplies
- ◆ Industrial Power Supplies
- ◆ High Density DC/DC Conversion

Typical Application Circuit

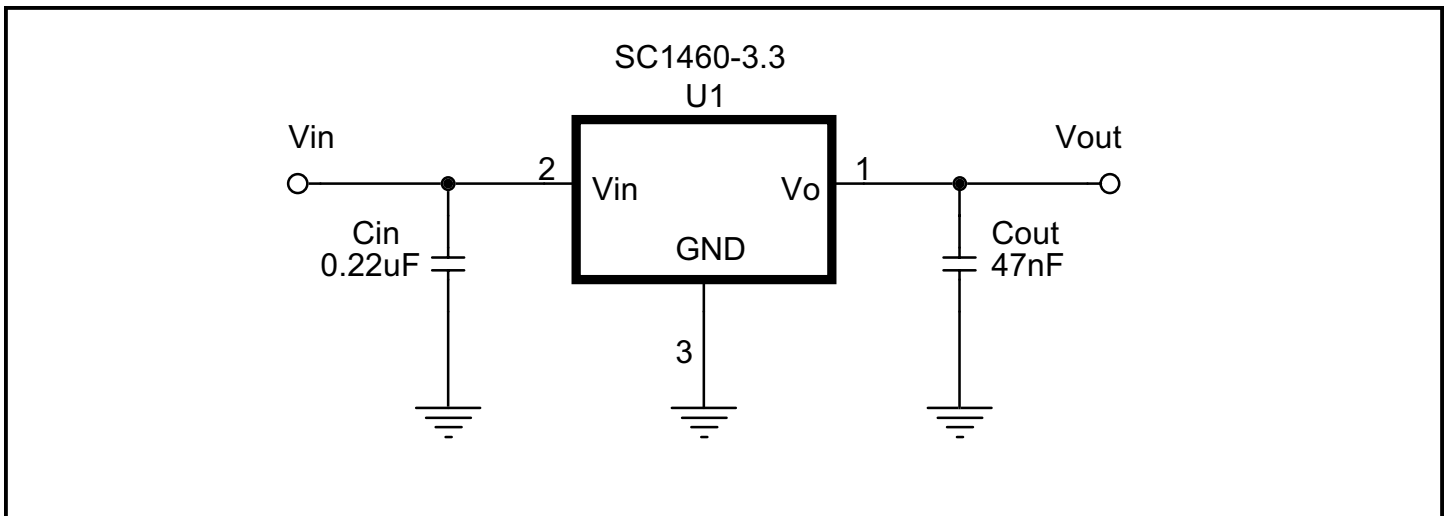

POWER MANAGEMENT
Absolute Maximum Ratings

Parameter	Symbol	Maximum	Units
Supply Voltage	V_{IN}	-0.3 to +4	V
Output Voltage	V_O	-0.3 to +6.0	V
Thermal Resistance Junction to Ambient	θ_{JA}	410	°C/W
Operating Temperature Range	T_A	0 to +70	°C
Junction Temperature Range	T_J	0 to 125	°C
Storage Temperature Range	T_{STG}	-65 to +150	°C
Lead Temperature (Soldering) 10 Seconds	T_L	300	°C
ESD Rating (Human Body Model)	ESD	4	kV

Electrical Characteristics

Unless specified: $V_{IN} = 2.5V$, $0 \leq I_O \leq 4mA$, $C_{IN} = 0.22\mu F$, $C_{OUT} = 47nF$, $T_A = 25^\circ C$. Values in **bold** apply over full operating temperature range

Parameter	Symbol	Conditions	Min	Typ	Max	Units
Input Supply Voltage	V_{IN}		2.25		3.63	V
Input Supply Current	I_{IN}	$I_O = 0mA$		100	150	μA
Output Voltage	V_O		-4	$1.32 \times V_{IN}$	4	%
Output Voltage	V_O		3.17	3.30	3.43	V
Output Ripple (pk-pk)	V_R	$I_O = 4mA$, $C_{OUT} = 47nF$		50		mV
Output Current	I_O		4	5		mA
Efficiency	η	$I_O = 4mA$	50	56		%
Oscillator Frequency	OSC			8		MHz
Time to Regulation at Turn-On	t_{ON}	Power up with $I_O = 4mA$		100		μs

POWER MANAGEMENT

Pin Configuration

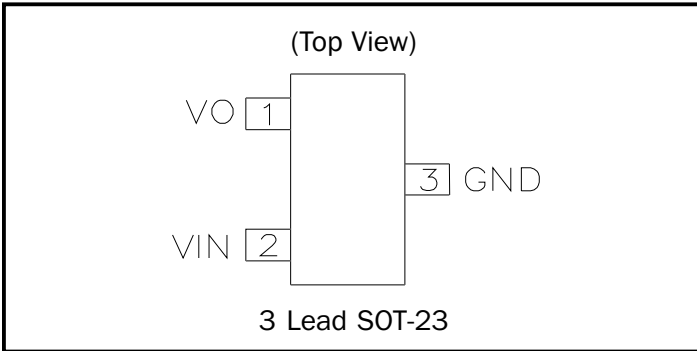

Ordering Information

Device ⁽¹⁾	Package
SC1460CSK-3.3TR	SOT-23-3L

Notes:

(1) Only available in tape and reel packaging. A reel contains 3000 devices.

Pin Descriptions

Pin #	Pin Name	Pin Function
1	VO	Voltage output.
2	VIN	Supply voltage input.
3	GND	Ground.

Block Diagram

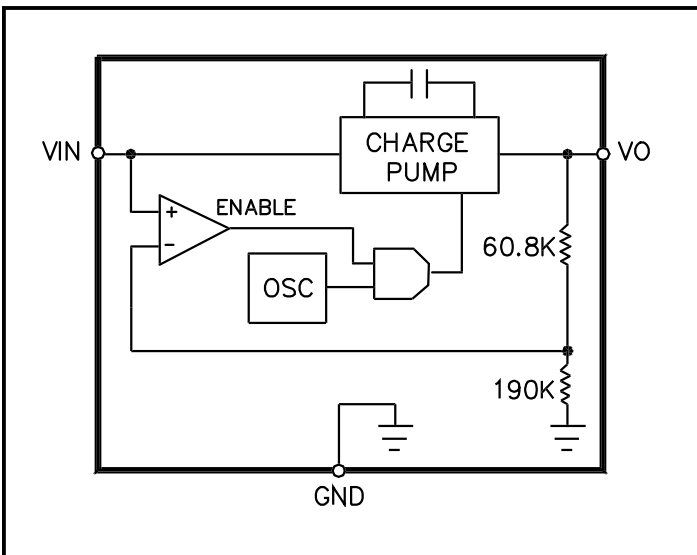

Marking Information

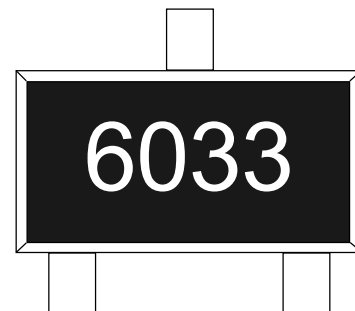

POWER MANAGEMENT

Typical Characteristics

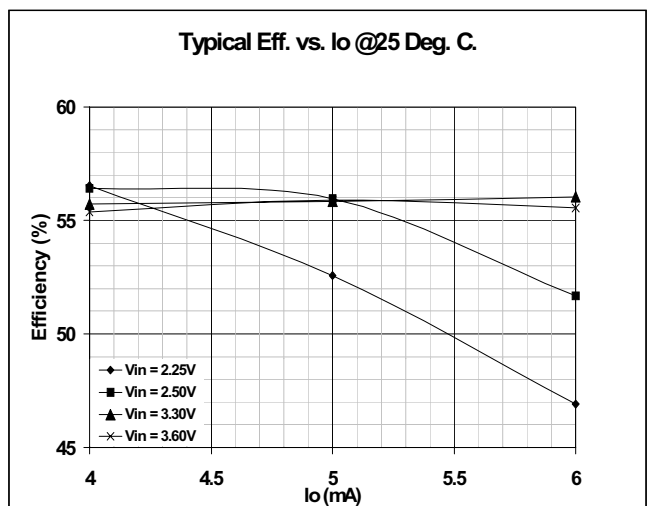
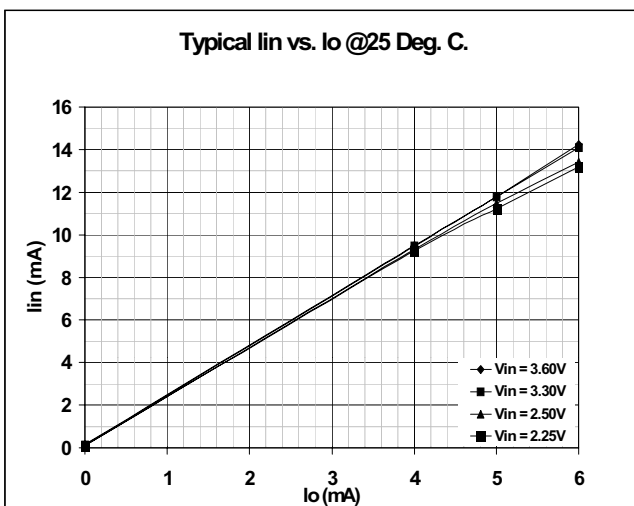
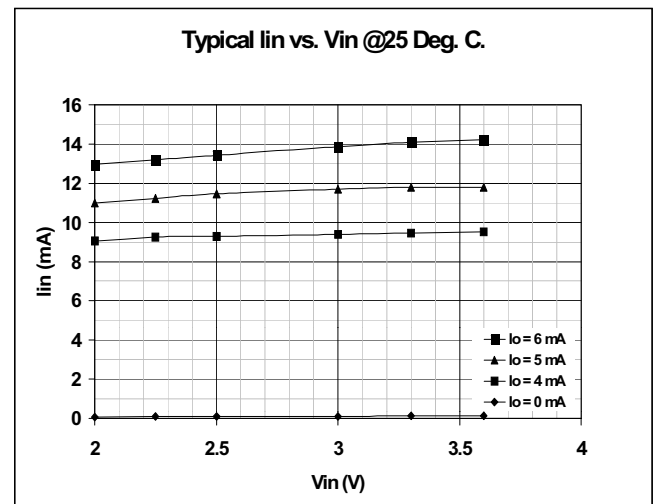
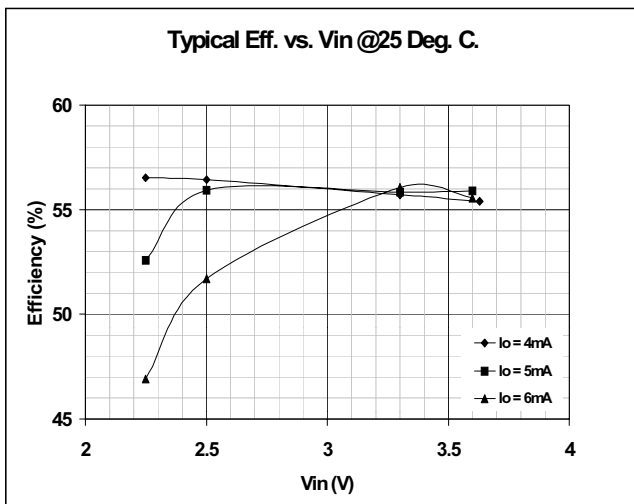
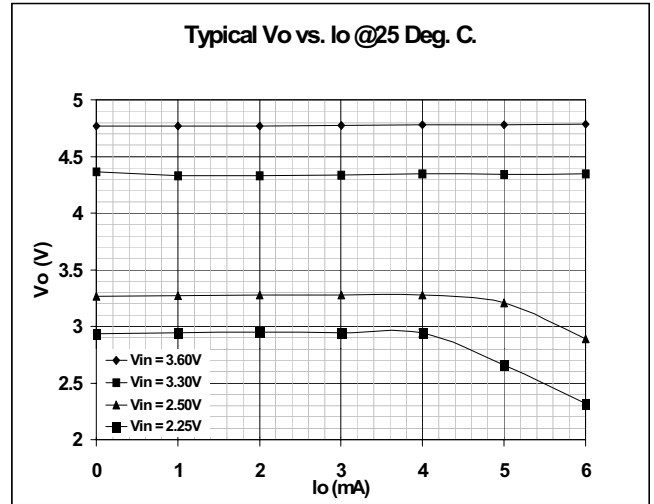
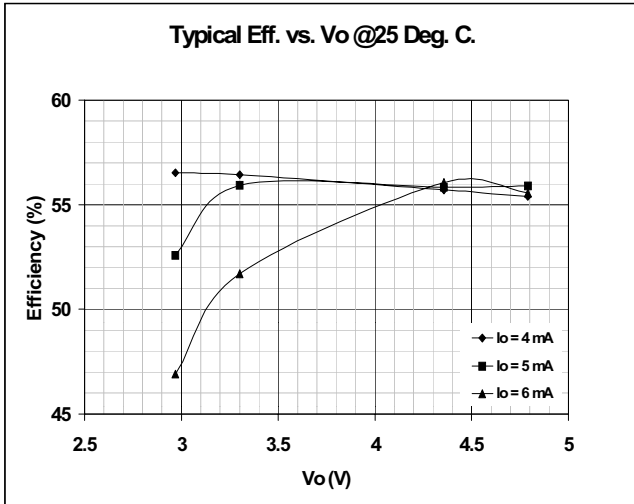

POWER MANAGEMENT

Typical Characteristics (Cont.)

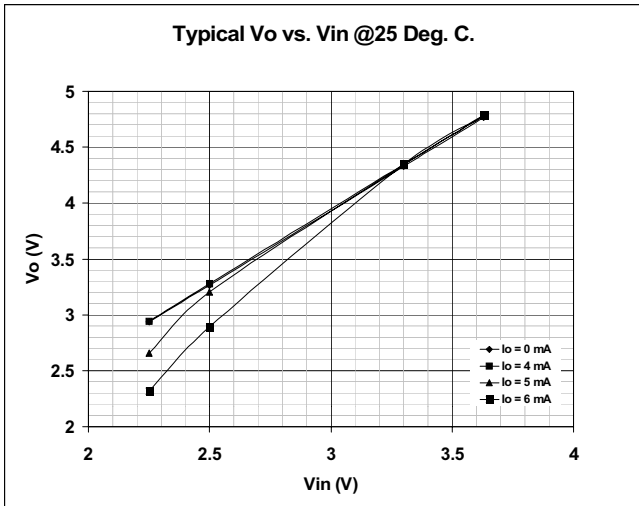

POWER MANAGEMENT

Typical Characteristics (Cont.)

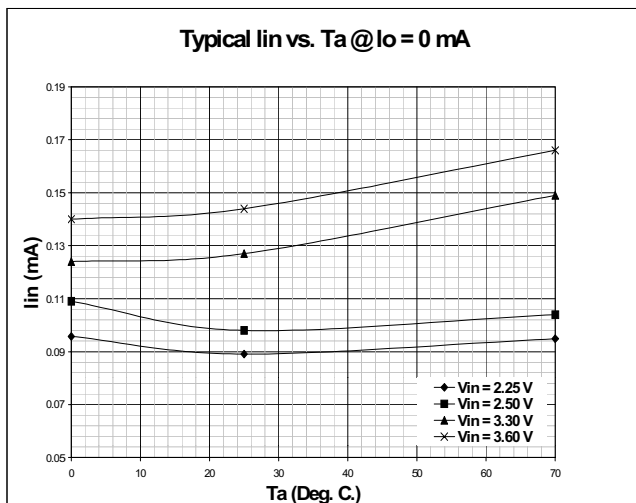
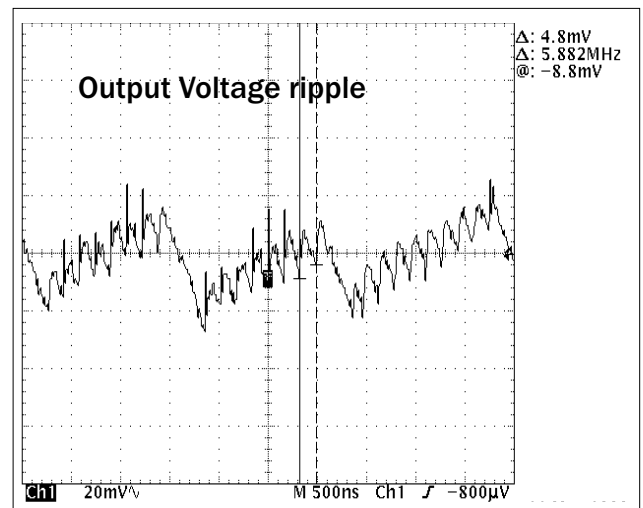
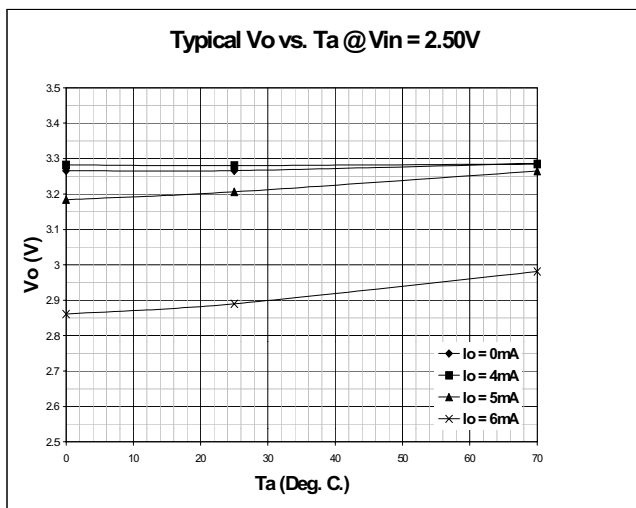
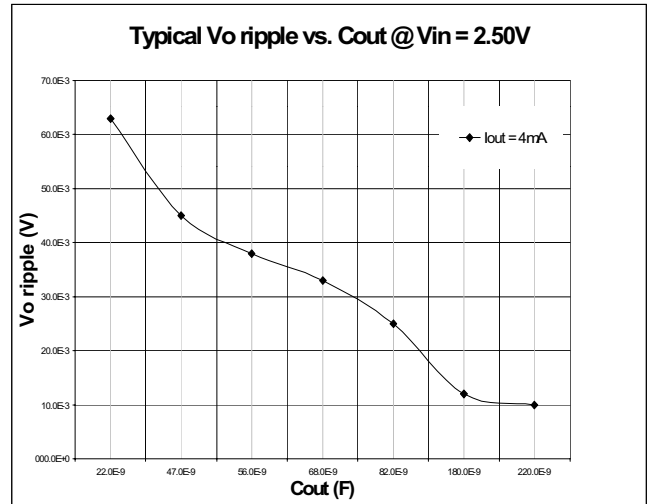
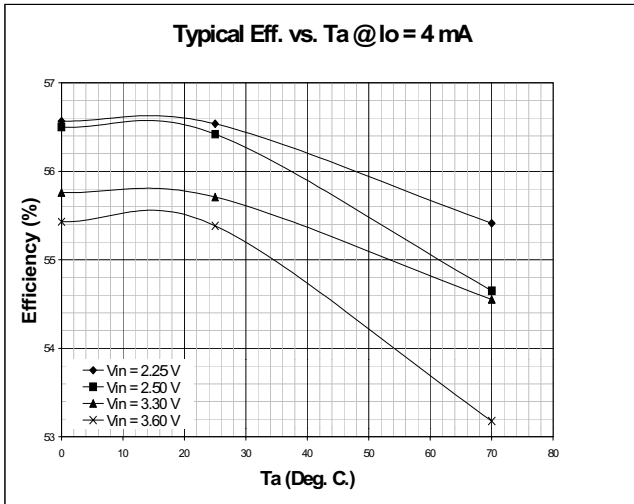

POWER MANAGEMENT

Outline Drawing - SOT-23-3L

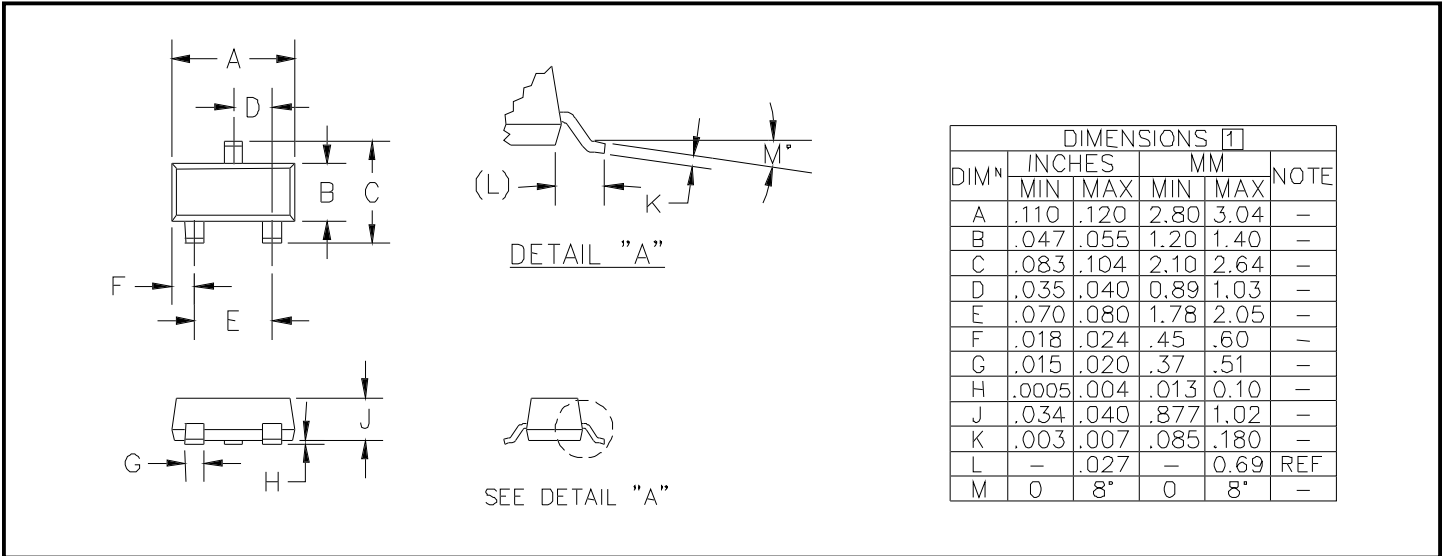

Land Pattern - SOT-23-3L

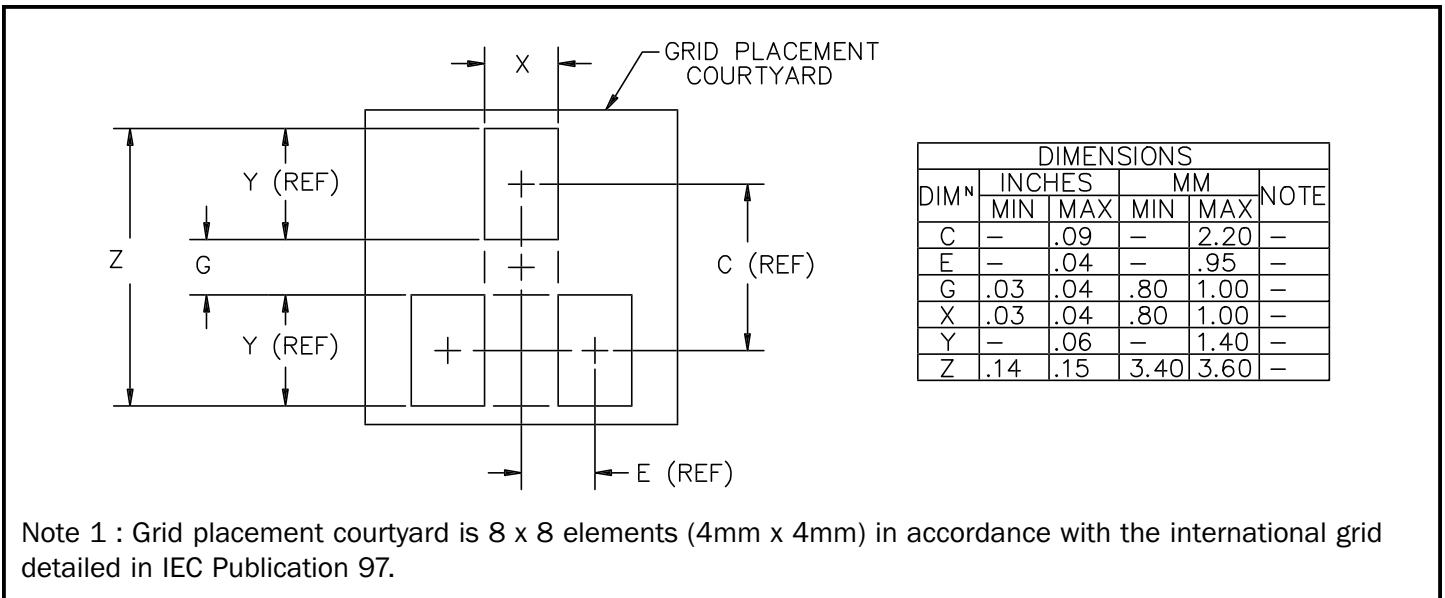

Contact Information

Semtech Corporation
 Power Management Products Division
 652 Mitchell Rd., Newbury Park, CA 91320
 Phone: (805)498-2111 FAX (805)498-3804