



PI5A4765

Low Voltage Dual SPDT Audio Clickless Analog Switch with Headphone/Mute Detection 2:1 Mux/DeMux Bus Switch

Features

- CMOS Technology for Bus and Analog Applications
- Low On-Resistance: $0.6\Omega @ 2.7V$.
- Wide V_{CC} Range: 1.65V to 5.5V
- Rail-to-Rail Signal Range
- Control Input Overvoltage Tolerance: 5.5V min.
- High Off Isolation: -50dB
- Crosstalk Rejection Reduces Signal Distortion: -80dB
- Break-Before-Make Switching
- Extended Industrial Temperature Range: $-40^{\circ}C$ to $85^{\circ}C$
- Packaging (Pb-free & Green available):
-12-ball CSP

Applications

- Cell Phones
- PDAs
- MP3 players
- Portable Instrumentation
- Computer Peripherals
- Speaker Headset Switching
- Power Routing
- Relay Replacement
- Audio/Video Signal Routing
- PCMCIA Cards
- Modems

Pin Description

Pin #	Pin # CSP	Name	Description
	A1, C1	NO _X	Data Port (Normally open)
	B1	V _{CC}	Positive Power Supply
	A3, C3	NC _X	Data Port (Normally closed)
	B4	GND	Ground
	A2, C2	COM _X	Common Output/Data Port
	B2	COMP0	Comparator Output
	B3	COMP-	Comparator Input
	A4, C4	IN _X	Logic Control

Note:

1. x = 1, or 2

Function Table

Logic Input (IN _X)	Function
0	NC _X Connected to COM _X
1	NO _X Connected to COM _X

Note:

1. x = 1, or 2

Description

Pericom Semiconductors PI5A4765 is a dual high-bandwidth, fast single-pole double throw (SPDT) CMOS switch. It can be used as an analog switch or as a low-delay bus switch. Specified over a wide operating power supply voltage, 1.65V to 5.5V, the PI5A4765 has a low On-Resistance of $0.6\Omega @ 2.7V$.

Break-before-make switching prevents both switches being enabled simultaneously. This eliminates signal disruption during switching. The control input, IN_X, tolerates input drive signals up to 6.0V, independent of supply voltage.

The PI5A4765 offers a headphone & mute detection function through utilization of an on-chip comparator. When the negative terminal of the comparator (COMP-) is less than the threshold (internally set to $V_{CC}/3$, COMP0 (comparator output) is a logic high. A logic low on COMP0 occurs when COMP- rises above the the threshold.

PI5A4765 also offers shunt switches connected to ground in order to dissipate capacitance that builds up on the unconnected NC or NO line. As a result, reduction of popping and clicking sounds is achieved when switching between audio sources.

Pin Configuration / Block Diagram (top view)

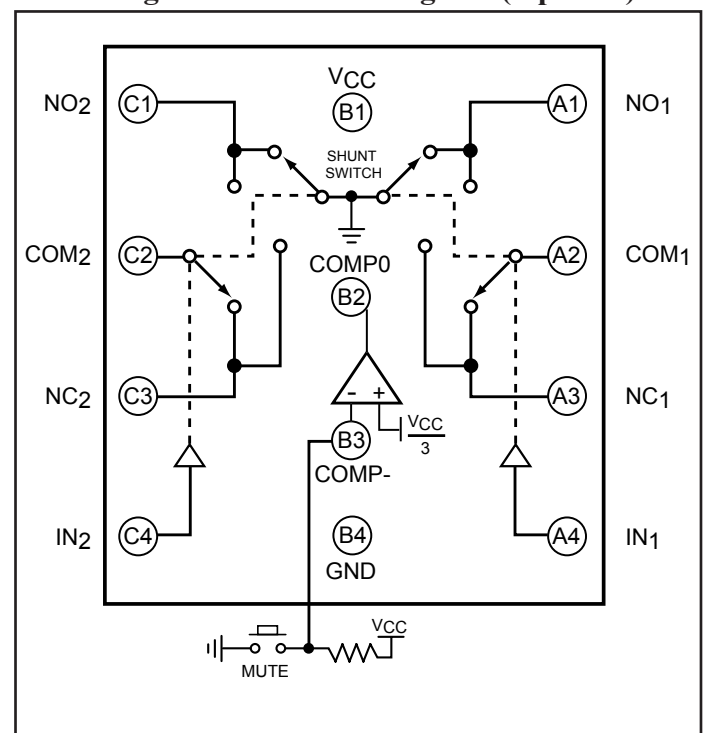

**Absolute Maximum Ratings⁽¹⁾**

Supply Voltage V_{CC}	-0.5V to +7V
DC Switch Voltage (V_S) ⁽²⁾	-0.5V to $V_{CC} + 0.5V$
DC Input Voltage (V_{IN}) ⁽²⁾	-0.5V to +7.0V
DC Output Current (V_{OUT})	128mA
DC V_{CC} or Ground Current (I_{CC}/I_{GND})	$\pm 100mA$
Storage Temperature Range (T_{STG})	-65°C to +150°C
Junction Temperature under Bias (T_J)	150°C
Junction Lead Temperature (T_L)	
(Soldering, 10 seconds)	260°C
Power Dissipation (P_D) @ +85°C	180mW

Recommended Operating Conditions⁽³⁾

Supply Voltage Operating (V_{CC})	1.65V to 5.5V
Control Input Voltage (V_{IN})	0V to V_{CC}
Switch Input Voltage (V_{IN})	0V to V_{CC}
Output Voltage (V_{OUT})	0V to V_{CC}
Operating Temperature (T_A)	-40°C to +85°C
Input Rise and Fall Time (t_r, t_f)	
Control Input $V_{CC} = 2.3V - 3.6V$	0ns/V to 10ns/V
Control Input $V_{CC} = 4.5V - 5.5V$	0ns/V to 5ns/V
Thermal Resistance (θ_{JA})	350°C/W

Notes:

1. Absolute Maximum Ratings" may cause permanent damage to the device. This is a stress only rating and operation of the device at these or any other conditions beyond those indicated in the operational sections of this specification is not implied.
2. The input and output negative voltage ratings may be exceeded if the input and output diode current ratings are observed.
3. Control input must be held HIGH or LOW; it must not float.

**DC Electrical Characteristics +3V Supply**(V_{CC} = 2.7V to 3.3V, T_A = T_{MIN} to T_{MAX}, unless otherwise noted. Typical values are at 3V and +25°C.)

Parameter	Symbol	Test Conditions	T _A	Min.	Typ.	Max.	Units
Analog Switch							
Analog Signal Range	V _{NO} , V _{NC} , V _{COM}		-40°C to 85°C	0		V _{CC}	V
NC On-Resistance	R _{ON(NC)}	V _{CC} = 2.7V, I _{COM} = 100mA, V _{NC} = 0 to V _{CC}	25°C		0.5		
			-40°C to 85°C		0.6		
NO On-Resistance	R _{ON(NO)}	V _{CC} = 2.7V, I _{COM} = 100mA, V _{NO} = 0 to V _{CC}	25°C		.05		
			-40°C to 85°C		0.6		
On-Resistance Match Between Channels	ΔR _{ON}	V _{CC} = 2.7V, I _{COM} = 100mA, V _{NO} or V _{NC} = 1.5V	25°C		.001		Ω
			-40°C to 85°C		.002		
NC On-Resistance Flatness	R _{ONF(NC)}	V _{CC} = 2.7V, I _{COM} = 100mA, V _{NC} = 0 to V _{CC}	25°C		.25	0.4	
NO On-Resistance Flatness	R _{ONF(NO)}	V _{CC} = 2.7V, I _{COM} = 100mA, V _{NO} = 0 to V _{CC}	25°C		.25	0.4	
Shunt Switch Resistance	R _{SH}	I _{NO} or I _{NC} = 10mA, V _{CC} = 2.7V	-40°C to 85°C		30		
NO or NC Off Leakage Current	I _{OFF (NO)} or I _{OFF (NC)}	V _{CC} = 2.7V, V _{NC} or V _{NO} = 0.3V, +2.5V, V _{COM} = +2.5V, 0.3V	25°C	-10		10	nA
			-40°C to 85°C	-80		80	
COM On Leakage Current	I _{COM (ON)}	V _{CC} = 2.7V, V _{NC} or V _{NO} = 0.3V, +2.5V, V _{COM} = +2.5V, 0.3V	25°C	-20		20	nA
			-40°C to 85°C	-160		160	
Digital I/O							
Input Logic High	V _{IH}	V _{CC} = 2.7V to 3.6V	-40°C to 85°C	1.8			V
		V _{CC} = 4.2V to 5.5V		2.0			
Input Logic Low	V _{IL}	V _{CC} = 2.7V to 3.6V	-40°C to 85°C			0.6	V
		V _{CC} = 4.2V to 5.5V				0.8	
IN Input Leakage Current	I _{IN}	V _{IN} = 0 or V _{CC}	-40°C to 85°C	-1		1	μA
Power Supply							
Power-Supply Range	V _{CC}		-40°C to 85°C	1.65		5.5	V
Supply Current	I _{CC}	V _{CC} = 5.5V, V _{IN} = 0 or V _{CC}	25°C		4.0	10.0	μA
Comparator							
Comparator Output High Voltage		I _{SOURCE} = 1mA		2.3			V
Comparator Output Low Voltage		I _{SINK} = 1mA				0.4	V
Comparator Input Leakage Current		V _{CMP-} = 0 to 2.7V				80	nA
Comparator Switching Time		V _{CC} = 2.7V, V _{CMP-} = 0V to V _{CC} , from 50% of V _{CMP-} to 50% of V _{CMP0}			1	2	μS
Comparator Power Supply Range				1.8		5.5	V
Comparator Threshold					V _{CC} 3		V



Switch and AC Characteristics

Parameter	Symbol	Test Conditions	T _A	Min.	Typ.	Max.	Units
Turn-On Time	t _{ON}	V _{CC} = 2.7V, V _{NO} or V _{NC} = 1.5V, R _L = 50Ω, C _L = 35pF, See Test Circuit Fig. 1 & 2	25°C		25.0	80.0	ns
			-40°C to 85°C			80.0	
Turn-Off Time	t _{OFF}	V _{CC} = 2.7V, V _{NO} or V _{NC} = 1.5V, R _L = 50Ω, C _L = 35pF, See Test Circuit Fig. 1 & 2	25°C		6	70.0	
			-40°C to 85°C			70.0	
Break-Before-Make Delay	t _{BBM}	V _{CC} = 2.7V, V _{NO} or V _{NC} = 1.5V, R _L = 50Ω, C _L = 35pF, See Test Circuit Fig. 3	25°C		21		
Charge Injection	Q	COM = 0, R _S = 0, C _L = 1nF, See Test Circuit Fig. 4	25°C		47		
Off-Isolation	O _{IRR}	C _L = 5pF, R _L = 50Ω, f = 100kHz, V _{COM} = 1 V _{RMS} , See Test Circuit Fig. 5	25°C		-53		dB
Crosstalk	X _{TALK}	C _L = 5pF, R _L = 50Ω, f = 100kHz, V _{COM} = 1 V _{RMS} , See Test Circuit Fig. 6	25°C		-84		
3dB Bandwidth	f _{3dB}	See Test Circuit Fig. 9			35		MHz

Capacitance

Parameter	Symbol	Test Conditions	T _A	Min.	Typ.	Max.	Units
NC On Capacitance	C _{NC (ON)}	f = 1MHz, See Test Circuit Fig. 8	25°C		168		pF
NO On Capacitance	C _{NO (ON)}	f = 1MHz, See Test Circuit Fig. 8	25°C		168		



Test Circuits and Timing Diagrams

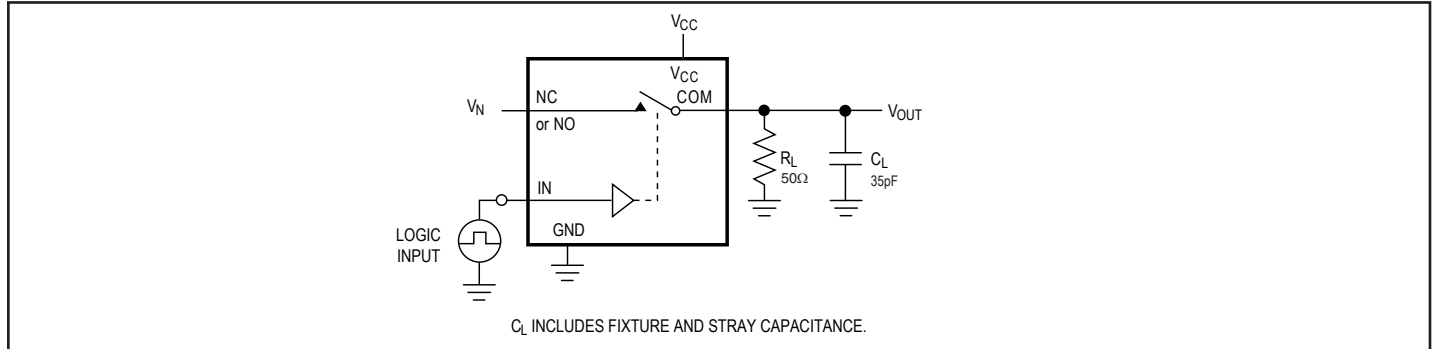

Figure 1. AC Test Circuit

Notes:

1. Unused input (NC or NO) must be grounded.

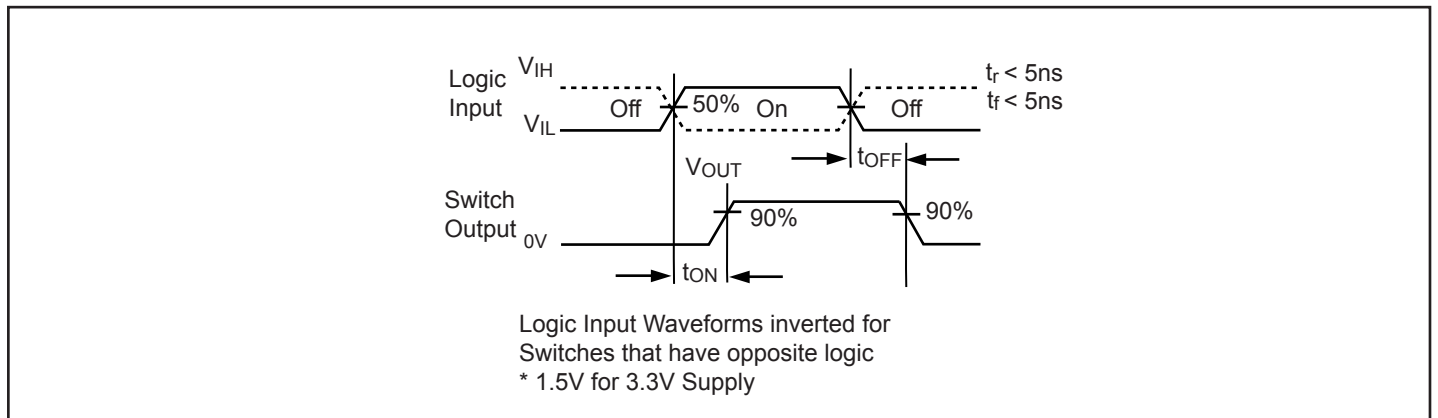

Figure 2. AC Waveforms

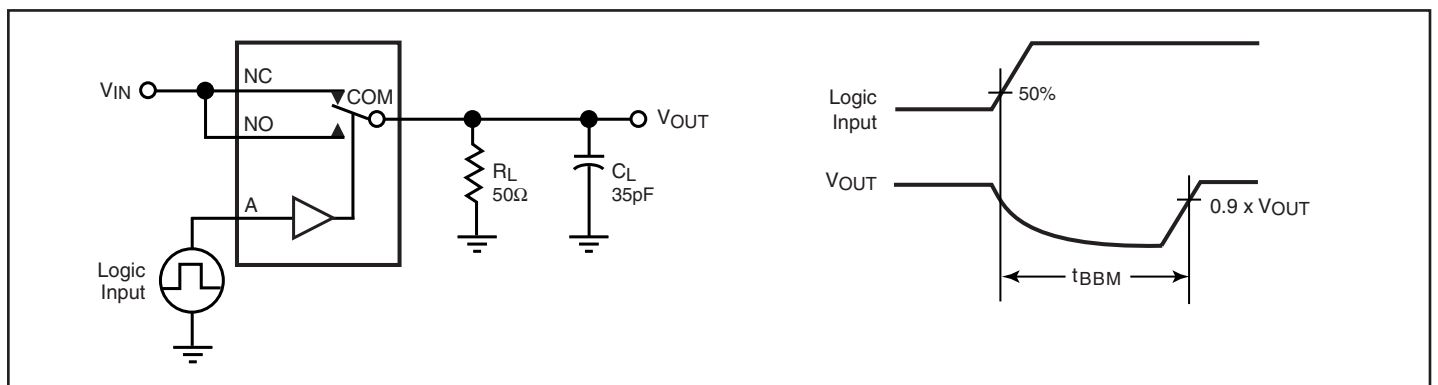

Figure 3. Break Before Make Interval Timing

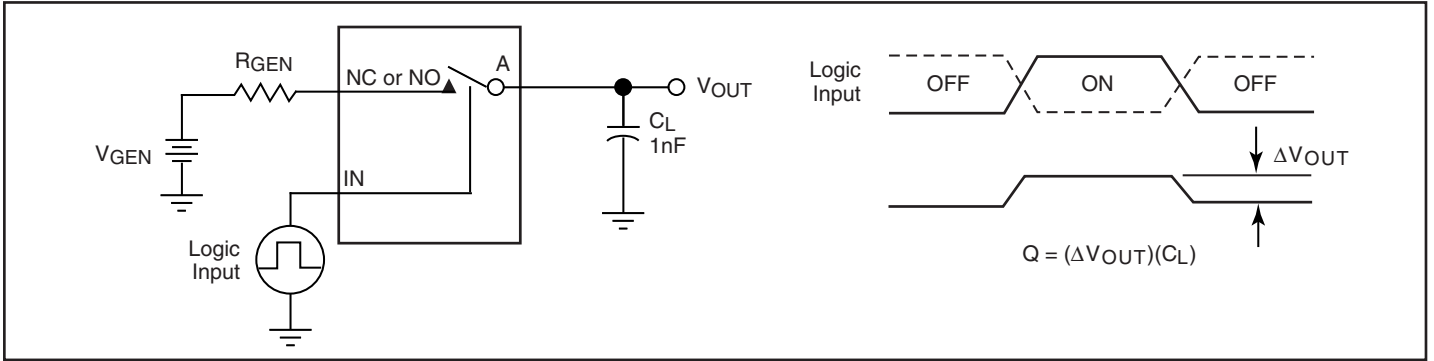

Figure 4. Charge Injection Test

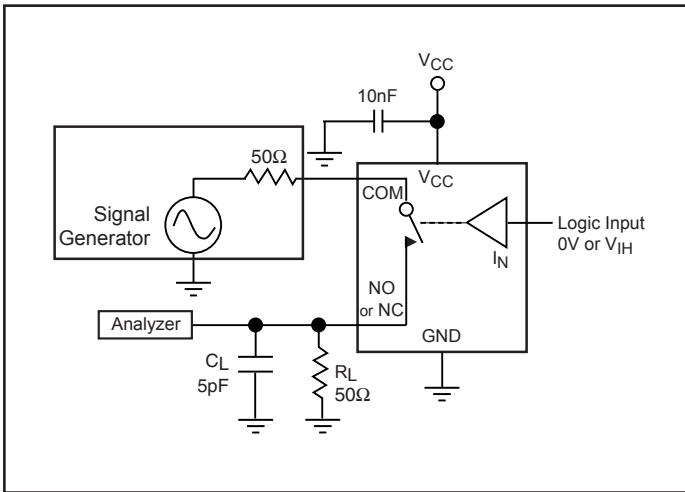

Figure 5. Off Isolation

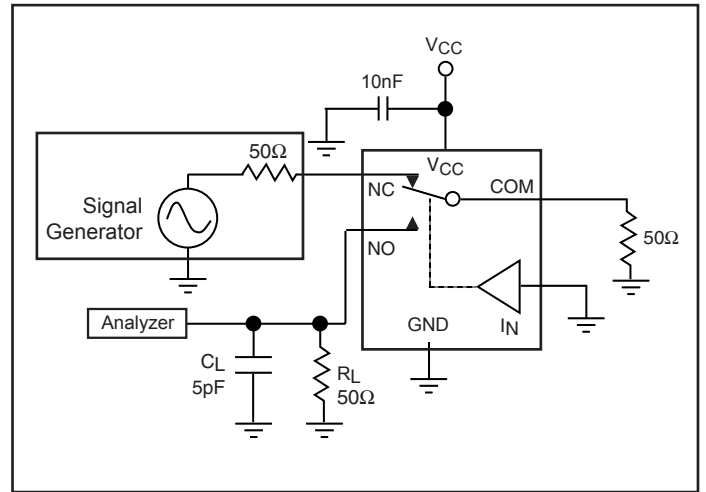

Figure 6. Crosstalk

Note:

1. Crosstalk measure from one channel to the pins of the other channel.

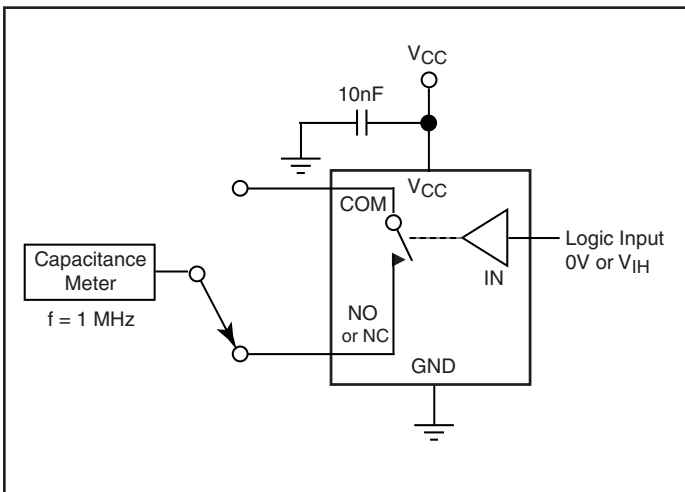

Figure 7. Channel Off Capacitance

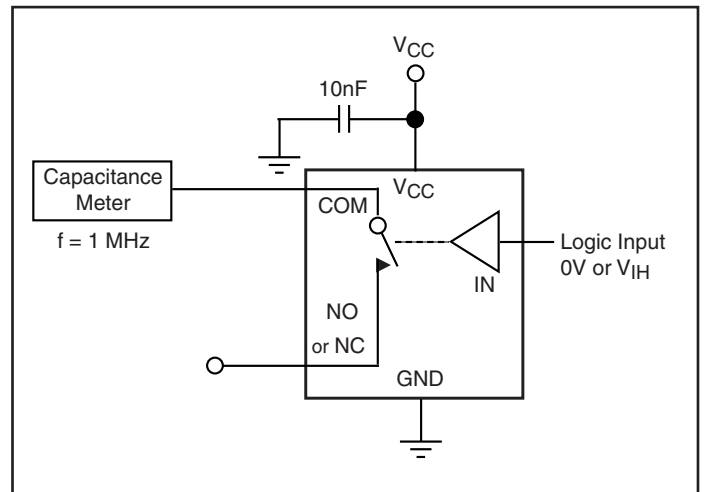

Figure 8. Channel On Capacitance

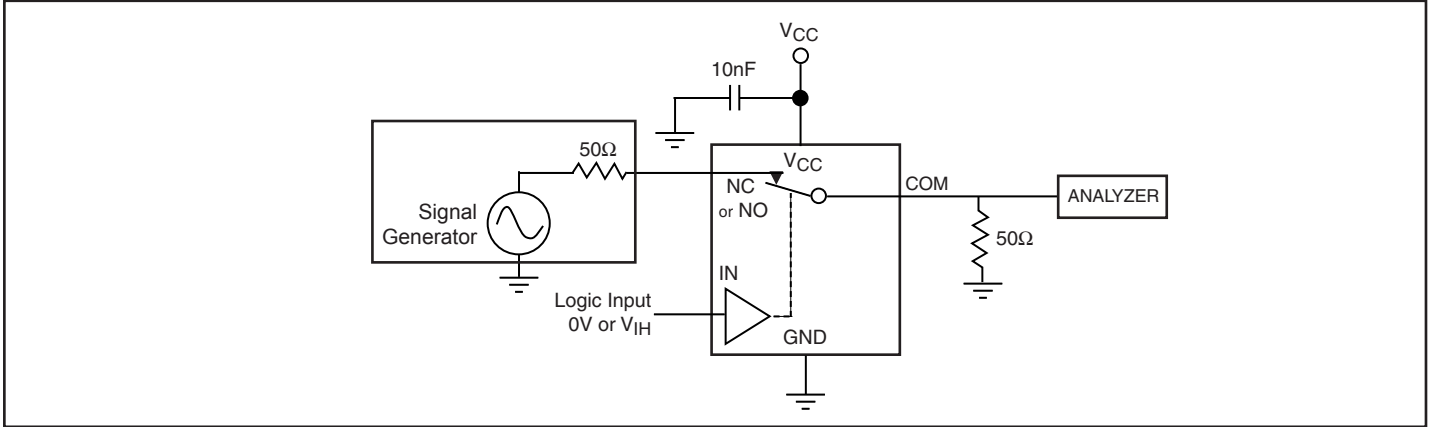
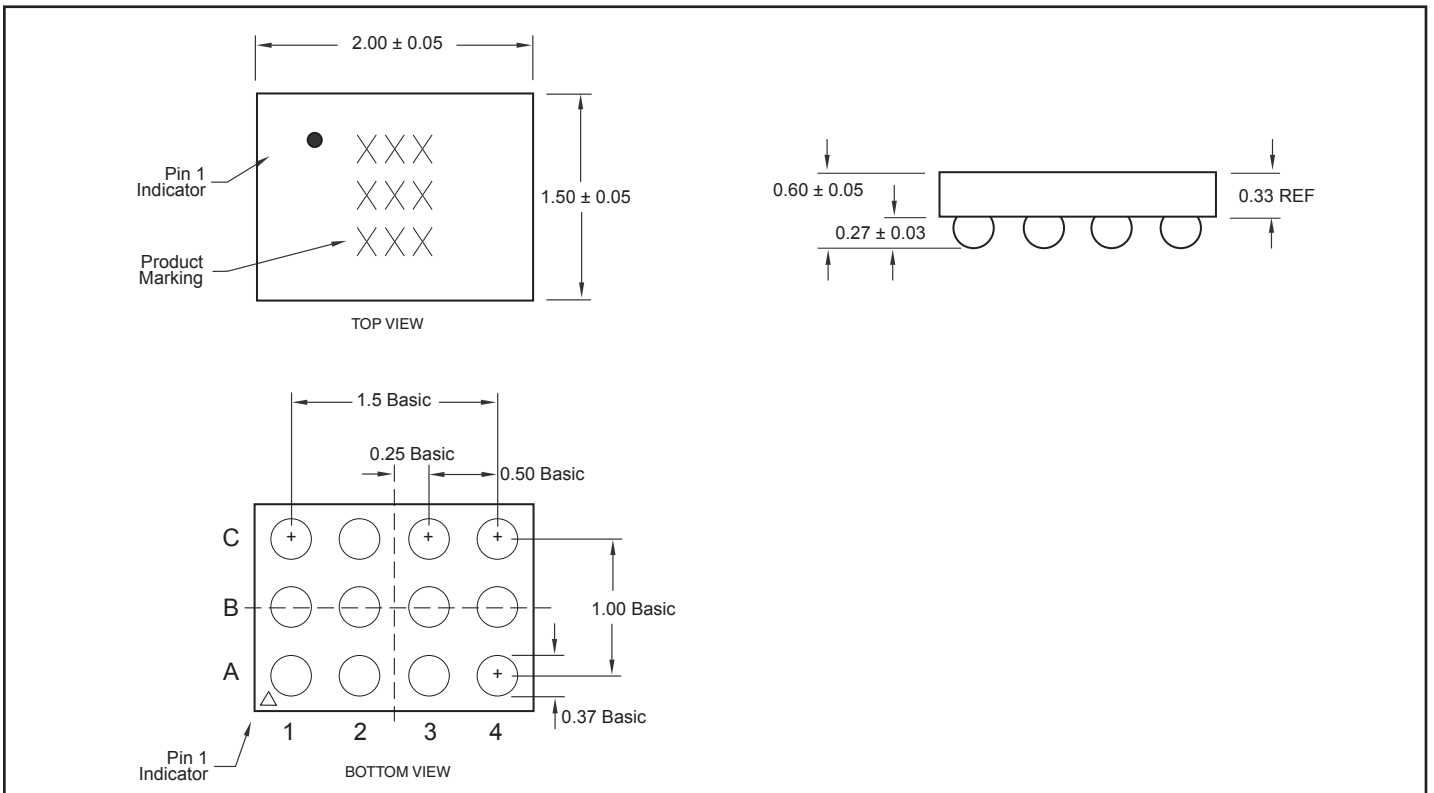

Figure 9. Bandwidth

Packaging Mechanical : 2x1.5mm CSP



Ordering Information

Ordering Code	Packaging Code	Package Type
PI5A4765GA	GA-12	12-ball CSP
PI5A4765GAE	GA-12	Pb-free & Green, 12-ball CSP
PI5A4765		Pb-free & Green, 10-contact TQFN

Notes:

- Thermal characteristics can be found on the company web site at www.pericom.com/packaging/