



MAX1169 Evaluation System/Evaluation Kit

General Description

The MAX1169 evaluation system (EV system) is a complete high-speed I²C™-compatible 16-bit data-acquisition system consisting of a MAX1169 evaluation kit (EV kit), a Maxim 68HC16 microcontroller (μC) module (68HC16MODULE-DIP), and a HS I²C-compatible module (HSI2CMOD).

The HSI2CMOD has a proven HS-mode I²C-compatible interface that supports the MAX1169's maximum 2-wire serial clock frequency of 1.7MHz. This solution is implemented on this module by using an Altera EPM3256AQC208-10-programmable logic device (PLD) and a DI2CM core from Digital Core Design.

Order the complete EV system (MAX1169EVC16) for a comprehensive evaluation of the MAX1169 using a PC. Order the EV kit (MAX1169EVKIT) separately to evaluate the MAX1169 with a user-supplied HS/fast/standard-mode I²C-compatible interface.

Purchase of I²C components of Maxim Integrated Products, Inc. or one of its sublicensed Associated Companies, conveys a license under the Philips I²C Patent Rights to use these components in an I²C system, provided that the system conforms to the I²C Standard Specifications as defined by Philips.

Windows is a registered trademark of Microsoft Corp.

Features

- ◆ HS I²C-Compatible Interface (1.7MHz)
- ◆ Fast I²C-Compatible Interface (400kHz)
- ◆ Standard I²C-Compatible Interface (100kHz)
- ◆ Proven PC Board Layout
- ◆ Windows® 95/98/2000/XP-Compatible Evaluation Software
- ◆ Fully Assembled and Tested

Ordering Information

PART	INTERFACE TYPE
MAX1169EVKIT	User-supplied HS/fast/standard I ² C-compatible
MAX1169EVC16	Windows GUI and HS I ² C compatible

Note: The MAX1169 software is included with the MAX1169 EV kit but is designed for use with the complete EV system. The EV system includes the EV kit, the 68HC16 μC module, and the HS I²C-compatible module. If the Windows software or HS I²C-compatible module is not required, order only the MAX1169 EV kit (instead of the entire EV system).

Note: To evaluate the MAX1169A_UD or MAX1169B_UD, request a free sample of the MAX1169A_UD or MAX1169B_UD when ordering the MAX1169 EV kit.

MAX1169EVKIT Component List

DESIGNATION	QTY	DESCRIPTION
C1	1	0.01μF ±10%, 50V X7R ceramic capacitor (0603) TDK C1608X7R1H103K
C2, C4, C7, C9, C11	5	10μF ±20%, 6.3V X5R ceramic capacitors (0805) TDK C2012X5R0J106M
C3, C5, C6, C8, C10	5	0.1μF ±10%, 16V X7R ceramic capacitors (0603) TDK C1608X7R1C104KT
FB1	1	Surface-mount ferrite bead (0603) TDK MMZ1608B601C
J1	1	2 x 10 right-angle female connector

DESIGNATION	QTY	DESCRIPTION
JU0–JU3	4	3-pin headers
JU4, JU5	2	2-pin headers
R1	1	4.7Ω ±5% resistor (0603)
R2	1	10Ω ±5% resistor (0603)
R3	0	Not installed
R4	0	Not installed
R5	1	4.7kΩ ±5% resistor (0603)
U1	1	16-bit ADC (14-pin TSSOP) Maxim MAX1169CCUD
U2	1	Op amp (5-pin SOT23) Maxim MAX4430EUK
None	1	MAX1169 EV kit PC board
None	1	MAX1169 EV kit software CD ROM
None	6	Shunts



MAX1169 Evaluation System/Evaluation Kit

MAX1169EVC16 System Component List

PART	QTY	DESCRIPTION
MAX1169EVKIT	1	MAX1169 EV kit
68HC16MODULE-DIP	1	68HC16 μ C module
HSI2CMOD	1	HS I ² C-compatible module

MAX1169EVKIT Files

FILE	DESCRIPTION
HELPPFILE.HTM	MAX1169 EV kit help file
INSTALL.EXE	Installs the EV kit files on your computer
KIT1169.C16	Software loaded into the 68HC16 μ C
MAX1169.EXE	Application program
UNINST.INI	Uninstalls the EV kit software

Component Suppliers

SUPPLIER	PHONE	WEBSITE
Altera Corporation	800-800-3753	www.altera.com
Digital Core Design	(48) 32-282-82-66	www.digitalcoredesign.com
Fairchild Semiconductor International	888-522-5372	www.fairchildsemi.com
TDK	847-803-6100	www.component.tdk.com

Note: Please indicate you are using the MAX1169 when contacting these component suppliers.

Quick Start

Recommended Equipment

- MAX1169EVC16 (MAX1169EVKIT, 68HC16MODULE-DIP, HSI2CMOD)
- Two DC power supplies:
 - +8V to +20V at 0.5A
 - +5V at 0.2A
- Analog signal source: 0 to +4.096V
- Windows 95/98/2000/XP computer with an available serial (COM) port
- 9-pin I/O extension cable (straight through female to male)

Procedure

Do not turn on the power until all the connections are made:

- 1) Verify that jumpers JU0–JU3 are connected to pins 1-2. This sets the I²C-compatible slave address of the MAX1169 to 0x7F.
- 2) Verify that jumper JU4 is OFF. This enables the internal 4.096V (typ) reference.
- 3) Verify that jumper JU5 is OFF. This disconnects the analog input buffer (U2) from AIN.
- 4) Carefully connect the 68HC16-module board to the HS I²C-compatible module board by aligning the 40-pin connector. Gently press them together. The two boards should be flush against one another.

- 5) Ensure that the ON/OFF switch (SW1) of the 68HC16 module is in the OFF position.
- 6) Connect the +8V to +20V power supply to the terminal block of the 68HC16 module (J2), which is located next to SW1, at the top of the μ C module. Observe the polarity marked on the board.
- 7) Carefully connect the HS I²C-compatible module to the MAX1169 EV kit board by aligning the 20-pin connector. Gently press them together. The two boards should be flush against one another.
- 8) Connect the +5V power supply between the AVDD and AGND pads on the MAX1169 EV kit board.
- 9) Connect the 9-pin serial cable from the computer's serial port to the DB9 connector of the 68HC16 module (J3).
- 10) Install the MAX1169 EV kit software on your computer by running the INSTALL.EXE program on the CD ROM. The program files are copied and icons are created in the programs section of the Windows **Start** menu.
- 11) Turn on the 68HC16 module by sliding SW1 to the ON position, and turn on all the power supplies.
- 12) Start the MAX1169 EV kit program by clicking on its icon in the programs section of the Windows **Start** menu.

MAX1169 Evaluation System/Evaluation Kit

- 13) The Windows program prompts you to click **OK** for automatic serial port selection. When you click **OK**, the KIT1169.C16 file automatically downloads to the module. Wait approximately 10s for the download to complete.
- 14) The EV kit software uses the value typed in the VREF field to translate the digital code to a voltage. The default is a +4.096V reference value. First, measure the reference voltage of the MAX1169. Then, after typing in the measured reference value into the VREF field, press the **Set VREF** button.
- 15) Apply an analog input signal (0 to VREF) between AIN and AGND. Observe the AIN voltage and code labels on the Windows program.

Detailed Description of Software

The main window of the evaluation software is shown in Figure 1. This window displays the voltage and code of the analog input signal AIN. The software supports both manual read or automatic read operations. The I²C-compatible serial-clock (SCL) frequency is selectable: HS mode (1.7MHz), fast mode (400kHz), or standard mode (100kHz). In HS-mode I²C-compatible systems, the communication and arbitration are always done in either fast mode or standard mode. Only data can be transmitted or received at HS-mode speeds. The software expects the use of a 4.096V reference on execution; however, this value can be changed in the software to accommodate a different reference value. Table 1 describes the controls in the main window of the evaluation software.

External Reference

To disable the MAX1169's internal +4.096V (typ) reference, select external reference mode with a shunt on JU4. Apply the new external reference voltage between the REF and GND pads on the MAX1169 EV kit board. After measuring the external reference voltage, enter it into the VREF field of the software (without the volt unit) and press the **Set VREF** button.

Detailed Description of Hardware

MAX1169 EV System

The MAX1169 EV system is a complete 16-bit data-acquisition system consisting of a MAX1169 EV kit, a 68HC16 μ C module, and a HS I²C-compatible module.

The complete MAX1169 EV system is used to evaluate the MAX1169 16-bit, I²C-compatible, analog-to-digital converter (ADC). See the *Quick Start* section for setup and operating instructions.

68HC16 Module

The 68HC16 μ C module utilizes Motorola's MC68HC16Z1 μ C and is fully assembled and tested. This module provides a working example of a μ C design for customers who have not yet chosen one for their system or who do not have the ability to connect the MAX1169 EV kit to their own system. The Windows software downloads an assembled program to the on-board random access memory of the 68HC16 module. For more information, refer to the 68HC16 module data sheet.

HS I²C-Compatible Module

The HS I²C-compatible module provides a 2-wire interface peripheral for the 68HC16 μ C module using an Altera EPM3256AQC208-10 PLD. This peripheral is implemented in the PLD by utilizing the D12CM core from Digital Core Design. The HS I²C-compatible module allows the 68HC16 module to be compatible with HS mode (1.7MHz), fast mode (400kHz), and standard mode (100kHz). This module is not required when evaluating the MAX1169 EV kit with a user-supplied I²C-compatible interface. For more information, refer to the HS I²C-compatible module data sheet.

MAX1169 EV kit

The MAX1169 EV kit board provides a proven layout for evaluating the MAX1169 16-bit, I²C-compatible ADC and can be obtained separately without the 68HC16 module and HS I²C-compatible module. The MAX1169 EV kit contains a 16-bit accurate analog input buffer (U2), connected in the unity-gain configuration. A REF pad has been provided on the MAX1169 EV kit board for evaluating the MAX1169 with an external reference. Refer to the MAX1169 data sheet to ensure all interface timing specifications are met when a user-supplied I²C-compatible interface is used.

MAX1169 Evaluation System/Evaluation Kit

Table 1. Software-Control Descriptions

CONTROL	DESCRIPTION
View	Allows the COM port debug form to be visible or checks for module status
Help	Allows the user to view the help file or the software's about box
Input Voltage: Code: AIN: 1.000000 V 16000	Displays the AIN voltage and code
I2C Compatible Read Address: 0x7F	Selects the I ² C-compatible slave address while reading
Set Vref 4.096	Allows the user to specify the actual reference value in the software. The EV kit software uses the value typed in the V _{REF} field to translate the digital code to a voltage. The default is a +4.096V reference value. First measure the reference voltage of the MAX1169. Then, after typing in the measured reference value into the V _{REF} field, press the Set VREF button.
Read	Performs a single-shot read operation
* <input checked="" type="checkbox"/> AutoRead	Performs a read operation specified by the control byte every 250ms. A blinking asterisk indicates AutoRead is active.
Data: <input checked="" type="radio"/> High Speed Mode: 1.7MHz <input type="radio"/> Fast Mode: 400kHz <input type="radio"/> Standard Mode: 100kHz	Selects the I ² C-compatible SCL frequency for data reception
Communication and Arbitration: <input checked="" type="radio"/> Fast Mode: 400kHz <input type="radio"/> Standard Mode: 100kHz	Selects the I ² C-compatible SCL frequency for communication and arbitration
HS I2C Compatible Module: Not Found	Displays the status of the 68HC16 module and HS I ² C-compatible module when the module status is requested in the View menu

MAX1169 Evaluation System/Evaluation Kit

Table 2. Slave Address Bit 0 (ADD0)

JUMPER	SHUNT POSITION	DESCRIPTION
JU0	1-2*	DVDD. ADD0 = 1.
	2-3	DGND. ADD0 = 0.

*Default configuration.

Table 3. Slave Address Bit 1 (ADD1)

JUMPER	SHUNT POSITION	DESCRIPTION
JU1	1-2*	DVDD. ADD1 = 1.
	2-3	DGND. ADD1 = 0.

*Default configuration.

Table 4. Slave Address Bit 2 (ADD2)

JUMPER	SHUNT POSITION	DESCRIPTION
JU2	1-2*	DVDD. ADD2 = 1.
	2-3	DGND. ADD2 = 0.

*Default configuration.

Table 5. Slave Address Bit 3 (ADD3)

JUMPER	SHUNT POSITION	DESCRIPTION
JU3	1-2*	DVDD. ADD3 = 1.
	2-3	DGND. ADD3 = 0.

*Default configuration.

Table 6. Reference Mode Select

JUMPER	SHUNT POSITION	DESCRIPTION
JU4	ON	External reference mode enabled. Connect an external reference to REF.
	OFF*	Internal +4.096V reference mode enabled.

*Default configuration.

Table 7. Analog Input Buffer

JUMPER	SHUNT POSITION	DESCRIPTION
JU5	ON	The analog input buffer is connected to AIN. Ensure +5V is applied to the BUF+5 pad and -5V is applied to the BUF-5 pad. Ensure that the noninverting (+) input to the analog input buffer is not left floating.
	OFF*	The analog input buffer is disconnected from AIN.

*Default configuration.

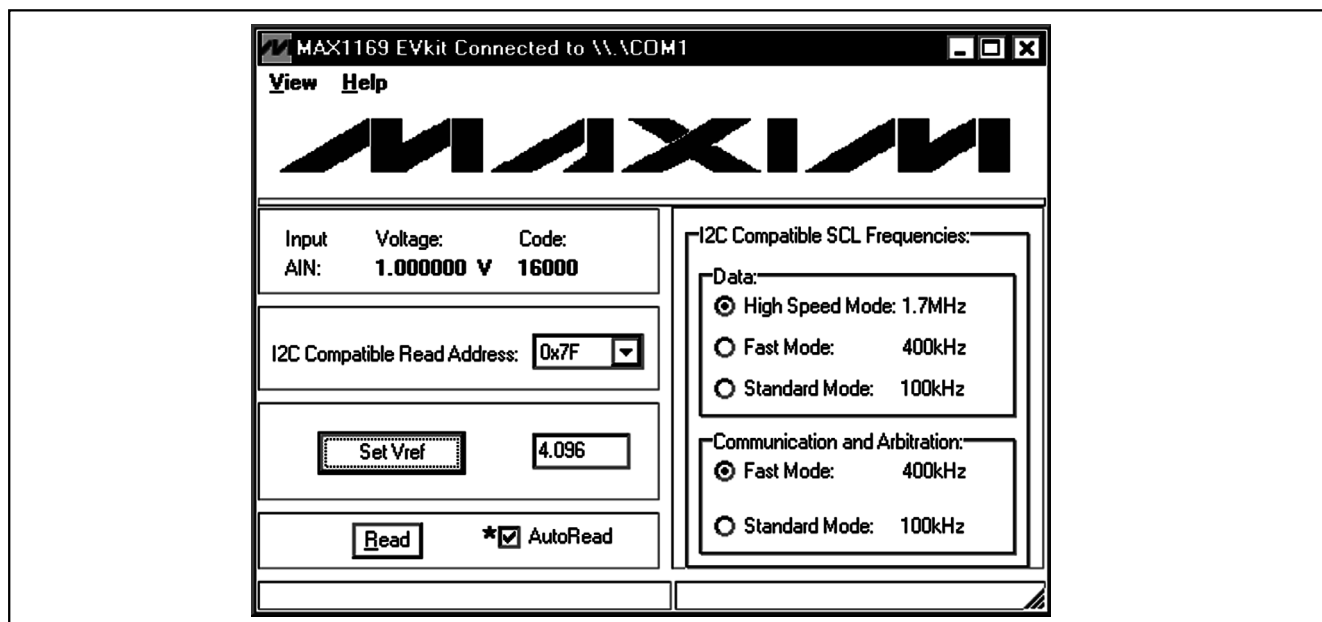

Figure 1. Main Window of the MAX1169 Evaluation Software

MAX1169 Evaluation System/Evaluation Kit

Evaluates: MAX1169

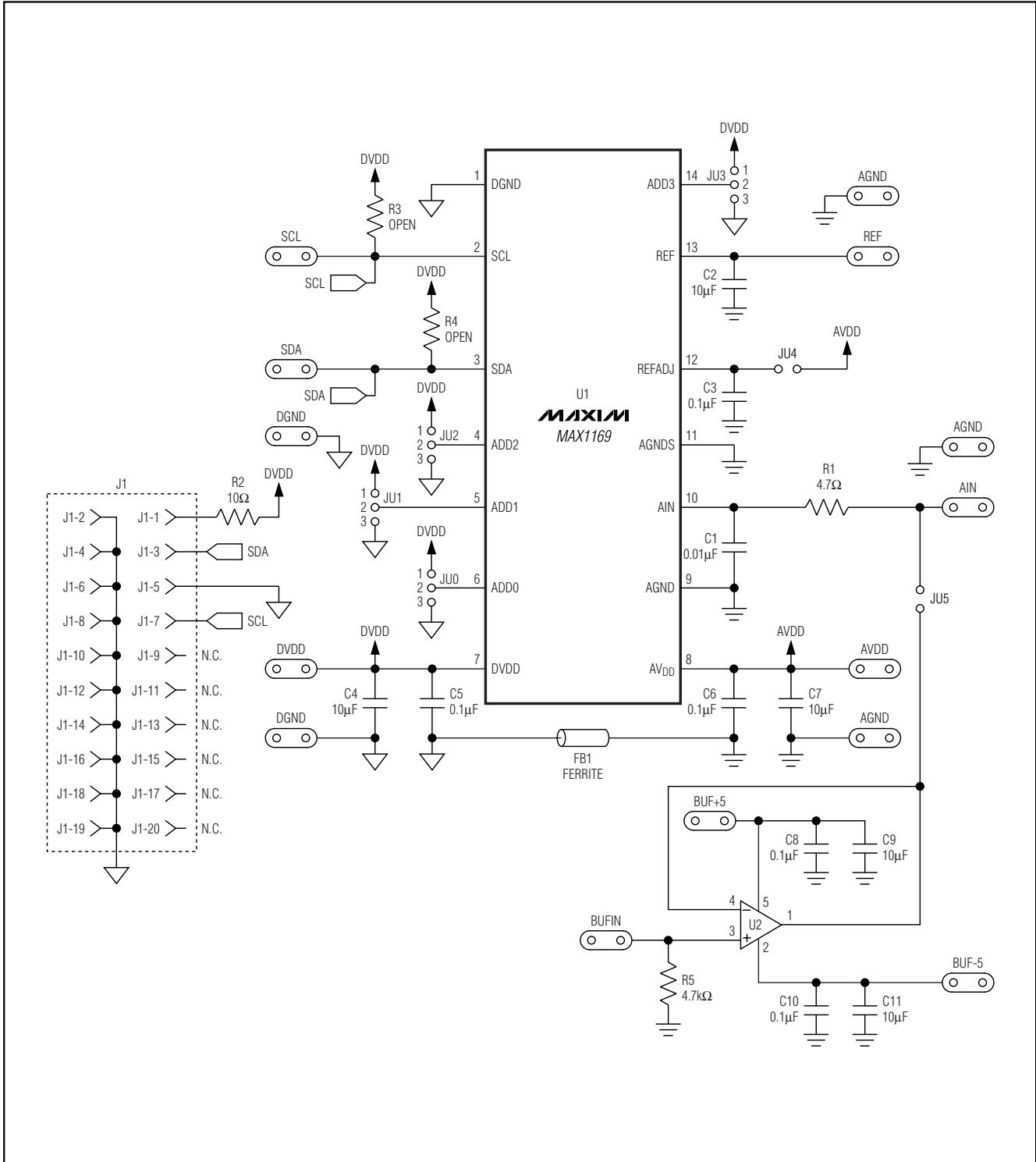

Figure 2. MAX1169EV Kit Schematic

MAX1169 Evaluation System/Evaluation Kit

Evaluates: MAX1169

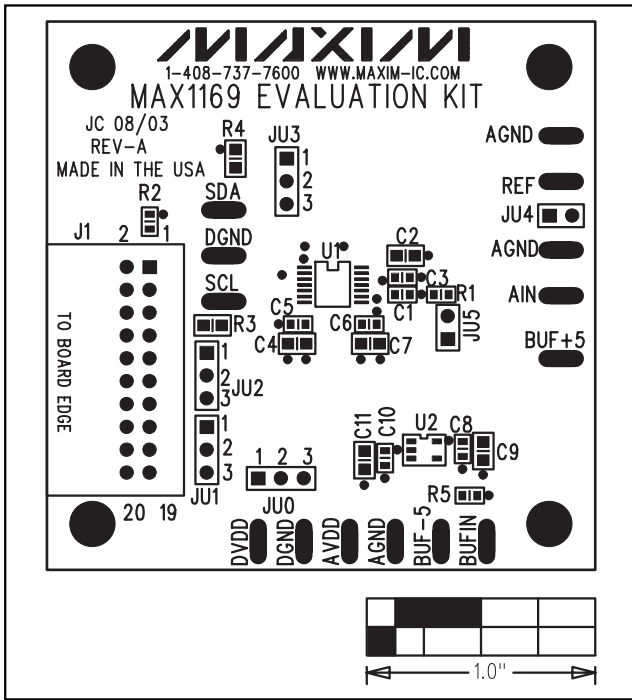

Figure 3. MAX1169 EV Kit Component Placement Guide—Component Side

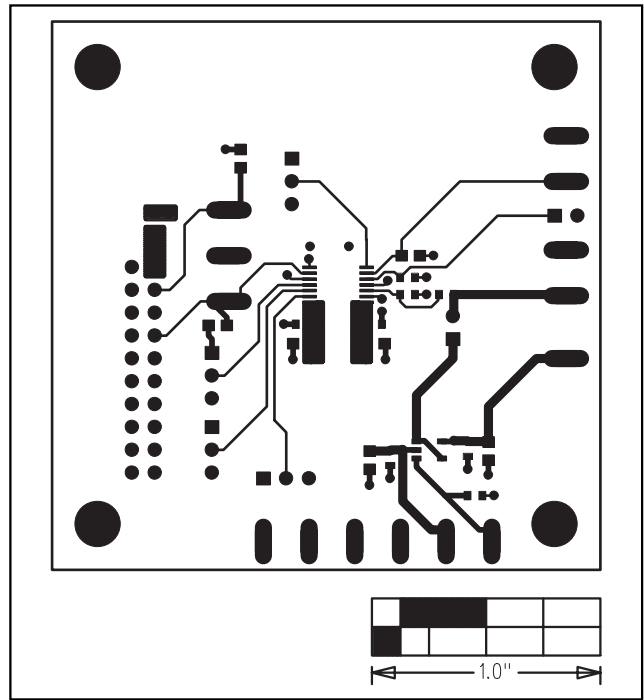

Figure 4. MAX1169 EV Kit PC Board Layout—Component Side

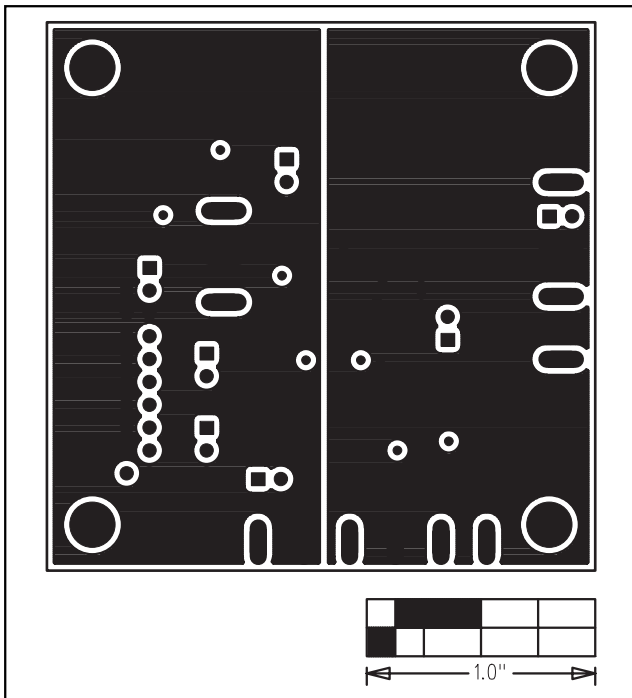

Figure 5. MAX1169 EV Kit PC Board Layout—Inner Layer 2 (GND)

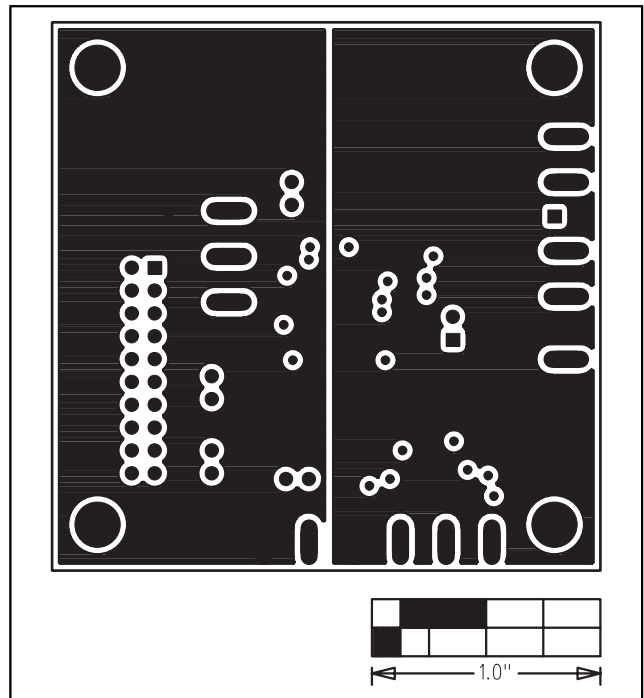

Figure 6. MAX1169 EV Kit PC Board Layout—Inner Layer 3 (VDD)

MAX1169 Evaluation System/Evaluation Kit

Evaluates: MAX1169

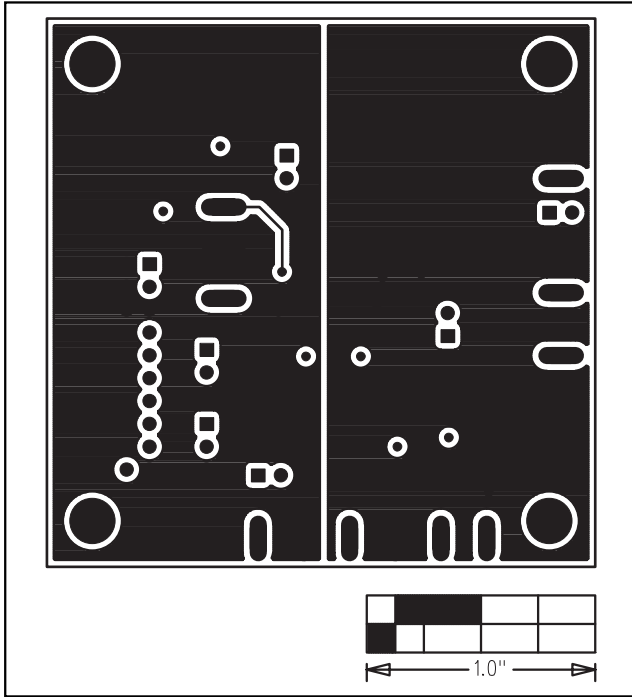

Figure 7. MAX1169 EV Kit PC Board Layout—Solder Side

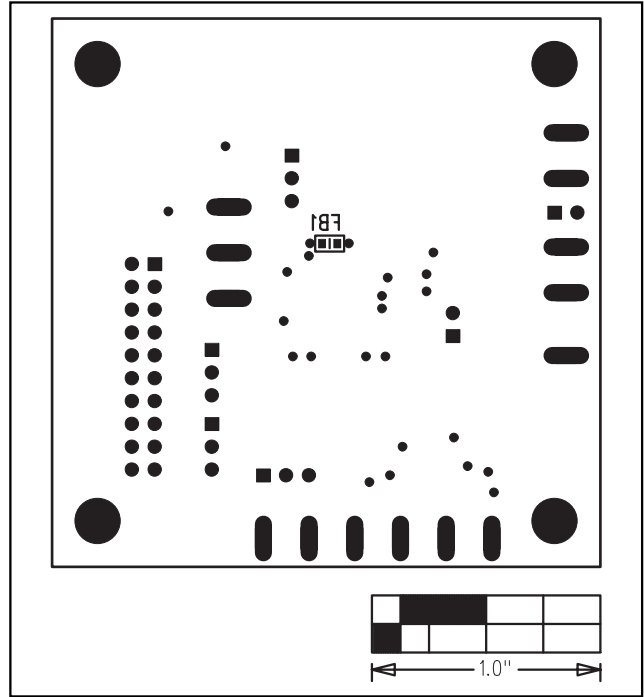

Figure 8. MAX1169 EV Kit Component Placement Guide—Solder Side

Maxim cannot assume responsibility for use of any circuitry other than circuitry entirely embodied in a Maxim product. No circuit patent licenses are implied. Maxim reserves the right to change the circuitry and specifications without notice at any time.

8 _____ **Maxim Integrated Products, 120 San Gabriel Drive, Sunnyvale, CA 94086 408-737-7600**