

To all our customers

---

## **Regarding the change of names mentioned in the document, such as Hitachi Electric and Hitachi XX, to Renesas Technology Corp.**

---

The semiconductor operations of Mitsubishi Electric and Hitachi were transferred to Renesas Technology Corporation on April 1st 2003. These operations include microcomputer, logic, analog and discrete devices, and memory chips other than DRAMs (flash memory, SRAMs etc.) Accordingly, although Hitachi, Hitachi, Ltd., Hitachi Semiconductors, and other Hitachi brand names are mentioned in the document, these names have in fact all been changed to Renesas Technology Corp. Thank you for your understanding. Except for our corporate trademark, logo and corporate statement, no changes whatsoever have been made to the contents of the document, and these changes do not constitute any alteration to the contents of the document itself.

Renesas Technology Home Page: <http://www.renesas.com>

Renesas Technology Corp.  
Customer Support Dept.  
April 1, 2003

## Cautions

Keep safety first in your circuit designs!

1. Renesas Technology Corporation puts the maximum effort into making semiconductor products better and more reliable, but there is always the possibility that trouble may occur with them. Trouble with semiconductors may lead to personal injury, fire or property damage.  
Remember to give due consideration to safety when making your circuit designs, with appropriate measures such as (i) placement of substitutive, auxiliary circuits, (ii) use of nonflammable material or (iii) prevention against any malfunction or mishap.

Notes regarding these materials

1. These materials are intended as a reference to assist our customers in the selection of the Renesas Technology Corporation product best suited to the customer's application; they do not convey any license under any intellectual property rights, or any other rights, belonging to Renesas Technology Corporation or a third party.
2. Renesas Technology Corporation assumes no responsibility for any damage, or infringement of any third-party's rights, originating in the use of any product data, diagrams, charts, programs, algorithms, or circuit application examples contained in these materials.
3. All information contained in these materials, including product data, diagrams, charts, programs and algorithms represents information on products at the time of publication of these materials, and are subject to change by Renesas Technology Corporation without notice due to product improvements or other reasons. It is therefore recommended that customers contact Renesas Technology Corporation or an authorized Renesas Technology Corporation product distributor for the latest product information before purchasing a product listed herein.  
The information described here may contain technical inaccuracies or typographical errors.  
Renesas Technology Corporation assumes no responsibility for any damage, liability, or other loss rising from these inaccuracies or errors.  
Please also pay attention to information published by Renesas Technology Corporation by various means, including the Renesas Technology Corporation Semiconductor home page (<http://www.renesas.com>).
4. When using any or all of the information contained in these materials, including product data, diagrams, charts, programs, and algorithms, please be sure to evaluate all information as a total system before making a final decision on the applicability of the information and products. Renesas Technology Corporation assumes no responsibility for any damage, liability or other loss resulting from the information contained herein.
5. Renesas Technology Corporation semiconductors are not designed or manufactured for use in a device or system that is used under circumstances in which human life is potentially at stake. Please contact Renesas Technology Corporation or an authorized Renesas Technology Corporation product distributor when considering the use of a product contained herein for any specific purposes, such as apparatus or systems for transportation, vehicular, medical, aerospace, nuclear, or undersea repeater use.
6. The prior written approval of Renesas Technology Corporation is necessary to reprint or reproduce in whole or in part these materials.
7. If these products or technologies are subject to the Japanese export control restrictions, they must be exported under a license from the Japanese government and cannot be imported into a country other than the approved destination.  
Any diversion or reexport contrary to the export control laws and regulations of Japan and/or the country of destination is prohibited.
8. Please contact Renesas Technology Corporation for further details on these materials or the products contained therein.

The revision list can be viewed directly by clicking the title page.

The revision list summarizes the locations of revisions and additions. Details should always be checked by referring to the relevant text.

# H8/3067 Series

H8/3067, H8/3066, H8/3065

H8/3067 F-ZTAT™

H8/3067F, H8/3067FR

Hardware Manual

**RENESAS**

ADE-602-135B

Rev. 3.0

22/2/99

Hitachi, Ltd.

# Cautions

1. Hitachi neither warrants nor grants licenses of any rights of Hitachi's or any third party's patent, copyright, trademark, or other intellectual property rights for information contained in this document. Hitachi bears no responsibility for problems that may arise with third party's rights, including intellectual property rights, in connection with use of the information contained in this document.
2. Products and product specifications may be subject to change without notice. Confirm that you have received the latest product standards or specifications before final design, purchase or use.
3. Hitachi makes every attempt to ensure that its products are of high quality and reliability. However, contact Hitachi's sales office before using the product in an application that demands especially high quality and reliability or where its failure or malfunction may directly threaten human life or cause risk of bodily injury, such as aerospace, aeronautics, nuclear power, combustion control, transportation, traffic, safety equipment or medical equipment for life support.
4. Design your application so that the product is used within the ranges guaranteed by Hitachi particularly for maximum rating, operating supply voltage range, heat radiation characteristics, installation conditions and other characteristics. Hitachi bears no responsibility for failure or damage when used beyond the guaranteed ranges. Even within the guaranteed ranges, consider normally foreseeable failure rates or failure modes in semiconductor devices and employ systemic measures such as fail-safes, so that the equipment incorporating Hitachi product does not cause bodily injury, fire or other consequential damage due to operation of the Hitachi product.
5. This product is not designed to be radiation resistant.
6. No one is permitted to reproduce or duplicate, in any form, the whole or part of this document without written approval from Hitachi.
7. Contact Hitachi's sales office for any questions regarding this document or Hitachi semiconductor products.

# Preface

The H8/3067 Series is a series of high-performance single-chip microcontrollers that integrate system supporting functions together with an H8/300H CPU core.

The H8/300H CPU has a 32-bit internal architecture with sixteen 16-bit general registers, and a concise, optimized instruction set designed for speed. It can address a 16-Mbyte linear address space.

The on-chip supporting functions include ROM, RAM, 16-bit timers, 8-bit timers, a programmable timing pattern controller (TPC), a watchdog timer (WDT), a serial communication interface (SCI), an A/D converter, a D/A converter, I/O ports, a DMA controller (DMAC), and other facilities. The three-channel SCI has been expanded to support the ISO/IEC7816-3 smart card interface. Functions have also been added to reduce power consumption in battery-powered applications: individual modules can be placed in standby, and the frequency of the system clock supplied to the chip can be divided down under software control.

The address space is divided into eight areas. The data bus width and access cycle length can be selected independently in each area, simplifying the connection of different types of memory. Seven MCU operating modes (modes 1 to 7) are provided, offering a choice of data bus width and address space size.

With these features, the H8/3067 Series offers easy implementation of compact, high-performance systems.

In addition to its mask ROM versions, the H8/3067 Series has an F-ZTAT™\* version with on-chip flash memory that can be programmed on-board. This version enables users to respond quickly and flexibly to changing application specifications.

This manual describes the H8/3067 Series hardware. For details of the instruction set, refer to the H8/300H Series Programming Manual.

Note: \* F-ZTAT™ (Flexible ZTAT) is a registered trademark of Hitachi, Ltd.

# List of Items Revised or Added for This Version

<b>Page</b>	<b>Item</b>	<b>Description</b>
65	3.3 System Control Register (SYSCR) Bits 6 to 4: Standby Timer Select 2 to 0	Modification of the bit 4
68	Table 3.3 Pin Functions in Each Mode	Modification of the mode 3 and mode 4 of the port A Modification of the Note 3
126	6.2.4 Bus Release Control Register (BRCR)	Modification of the bit 4
137	6.2.12 Address Control Register (ADRCR)	Modification of the bit 0
304	Table 8.21 Port A Pin Functions (Modes 1 to 7)	Addition and Modification of the Note 1
305	8.12.1 Overview	Modification
310 to 311	Table 8.23 Port B Pin Functions (Modes 1 to 5)	Modification
313	Table 8.24 Port B Pin Functions (Modes 6 to 7)	Modification
327	9.2.3 Timer Mode Register (TMDR)	Modification of the counting direction
352	9.4.2 Basic Functions External Clock Source	Modification of the detection edge
364	9.4.5 Phase Counting Mode	Modification
392	10.2.4 Timer Control Register (TCR)	Modification of the bits 2 to 0
399	Figure 10.8 Count Timing for Internal Clock Input	Modification of the timing Supplementation of Note
400 to 403	Figure 10.9 to Figure 10.16	Modification of the timing
410 to 415	Figure 10.19 to Figure 10.24	Modification of the timing
416	10.7.9 TCNT Operation at Internal Clock Source Switchover	Modification
417	Table 10.6 Internal Clock Switchover and TCNT Operation	Modification
660	20.4.6 Cautions on Clearing the Software Standby Mode of F-ZTAT Version	Addition
675	Table 21.4 Clock Timing	Changes in numerical value of Condition B
677	Table 21.6 Bus Timing	Changes in numerical value of Condition B
694	Table 21.12 Permissible Output Currents	Change in numerical value of Condition
698	Table 21.15 Bus Timing	Changes in numerical value of Condition A

# Contents

Section 1	Overview .....	1
1.1	Overview.....	1
1.2	Block Diagram.....	6
1.3	Pin Description .....	7
1.3.1	Pin Arrangement .....	7
1.3.2	Pin Functions.....	9
1.3.3	Pin Assignments in Each Mode.....	14
1.4	Notes on Flash Memory R Version Model.....	18
1.4.1	Pin Arrangement .....	18
1.4.2	Product Type Names and Markings .....	18
1.4.3	Differences in Flash Memory R Version.....	19
Section 2	CPU.....	21
2.1	Overview.....	21
2.1.1	Features .....	21
2.1.2	Differences from H8/300 CPU.....	22
2.2	CPU Operating Modes .....	23
2.3	Address Space.....	24
2.4	Register Configuration .....	25
2.4.1	Overview .....	25
2.4.2	General Registers.....	26
2.4.3	Control Registers.....	27
2.4.4	Initial CPU Register Values .....	28
2.5	Data Formats.....	29
2.5.1	General Register Data Formats .....	29
2.5.2	Memory Data Formats.....	30
2.6	Instruction Set.....	32
2.6.1	Instruction Set Overview.....	32
2.6.2	Instructions and Addressing Modes .....	33
2.6.3	Tables of Instructions Classified by Function.....	34
2.6.4	Basic Instruction Formats.....	43
2.6.5	Notes on Use of Bit Manipulation Instructions.....	45
2.7	Addressing Modes and Effective Address Calculation .....	47
2.7.1	Addressing Modes.....	47
2.7.2	Effective Address Calculation.....	49
2.8	Processing States .....	53
2.8.1	Overview .....	53
2.8.2	Program Execution State.....	54
2.8.3	Exception-Handling State .....	54

2.8.4	Exception-Handling Sequences.....	56
2.8.5	Bus-Released State .....	57
2.8.6	Reset State .....	57
2.8.7	Power-Down State.....	57
2.9	Basic Operational Timing.....	58
2.9.1	Overview .....	58
2.9.2	On-Chip Memory Access Timing .....	58
2.9.3	On-Chip Supporting Module Access Timing.....	59
2.9.4	Access to External Address Space .....	60
<b>Section 3 MCU Operating Modes .....</b>		<b>61</b>
3.1	Overview.....	61
3.1.1	Operating Mode Selection.....	61
3.1.2	Register Configuration .....	62
3.2	Mode Control Register (MDCR).....	63
3.3	System Control Register (SYSCR).....	64
3.4	Operating Mode Descriptions.....	66
3.4.1	Mode 1.....	66
3.4.2	Mode 2.....	66
3.4.3	Mode 3.....	66
3.4.4	Mode 4.....	67
3.4.5	Mode 5.....	67
3.4.6	Mode 6.....	67
3.4.7	Mode 7.....	67
3.5	Pin Functions in Each Operating Mode.....	68
3.6	Memory Map in Each Operating Mode.....	68
3.6.1	Note on Reserved Areas .....	68
<b>Section 4 Exception Handling.....</b>		<b>75</b>
4.1	Overview.....	75
4.1.1	Exception Handling Types and Priority .....	75
4.1.2	Exception Handling Operation .....	75
4.1.3	Exception Vector Table.....	76
4.2	Reset .....	78
4.2.1	Overview .....	78
4.2.2	Reset Sequence.....	78
4.2.3	Interrupts after Reset .....	81
4.3	Interrupts.....	82
4.4	Trap Instruction .....	83
4.5	Stack Status after Exception Handling .....	84
4.6	Notes on Stack Usage.....	85



Section 5	Interrupt Controller .....	87
5.1	Overview.....	87
5.1.1	Features .....	87
5.1.2	Block Diagram.....	88
5.1.3	Pin Configuration .....	89
5.1.4	Register Configuration .....	89
5.2	Register Descriptions.....	90
5.2.1	System Control Register (SYSCR) .....	90
5.2.2	Interrupt Priority Registers A and B (IPRA, IPRB) .....	91
5.2.3	IRQ Status Register (ISR).....	98
5.2.4	IRQ Enable Register (IER) .....	99
5.2.5	IRQ Sense Control Register (ISCR).....	100
5.3	Interrupt Sources.....	101
5.3.1	External Interrupts.....	101
5.3.2	Internal Interrupts .....	102
5.3.3	Interrupt Vector Table.....	102
5.4	Interrupt Operation .....	106
5.4.1	Interrupt Handling Process .....	106
5.4.2	Interrupt Sequence.....	111
5.4.3	Interrupt Response Time .....	112
5.5	Usage Notes .....	113
5.5.1	Contention between Interrupt and Interrupt-Disabling Instruction.....	113
5.5.2	Instructions that Inhibit Interrupts.....	114
5.5.3	Interrupts during EEPMOV Instruction Execution.....	114
Section 6	Bus Controller.....	115
6.1	Overview.....	115
6.1.1	Features .....	115
6.1.2	Block Diagram.....	117
6.1.3	Pin Configuration .....	118
6.1.4	Register Configuration .....	119
6.2	Register Descriptions.....	120
6.2.1	Bus Width Control Register (ABWCR).....	120
6.2.2	Access State Control Register (ASTCR).....	121
6.2.3	Wait Control Registers H and L (WCRH, WCRL).....	121
6.2.4	Bus Release Control Register (BRCR) .....	125
6.2.5	Bus Control Register (BCR) .....	126
6.2.6	Chip Select Control Register (CSCR).....	128
6.2.7	DRAM Control Register A (DRCRA) .....	129
6.2.8	DRAM Control Register B (DRCRB).....	131
6.2.9	Refresh Timer Control/Status Register (RTMCSR) .....	134
6.2.10	Refresh Timer Counter (RTCNT).....	135

6.2.11	Refresh Time Constant Register (RTCOR).....	136
6.2.12	Address Control Register (ADRCR) (Provided Only in Flash Memory R Version and Mask ROM Versions).....	137
6.3	Operation .....	138
6.3.1	Area Division.....	138
6.3.2	Bus Specifications .....	141
6.3.3	Memory Interfaces.....	142
6.3.4	Chip Select Signals.....	142
6.3.5	Address Output Method (Function Provided Only in Flash Memory R Version and Mask ROM Versions).....	144
6.4	Basic Bus Interface.....	146
6.4.1	Overview .....	146
6.4.2	Data Size and Data Alignment .....	146
6.4.3	Valid Strobes .....	147
6.4.4	Memory Areas.....	148
6.4.5	Basic Bus Control Signal Timing.....	150
6.4.6	Wait Control .....	157
6.5	DRAM Interface.....	159
6.5.1	Overview .....	159
6.5.2	DRAM Space and $\overline{\text{RAS}}$ Output Pin Settings .....	159
6.5.3	Address Multiplexing .....	160
6.5.4	Data Bus .....	160
6.5.5	Pins Used for DRAM Interface.....	160
6.5.6	Basic Timing .....	161
6.5.7	Precharge State Control.....	162
6.5.8	Wait Control .....	163
6.5.9	Byte Access Control and $\overline{\text{CAS}}$ Output Pin.....	164
6.5.10	Burst Operation .....	166
6.5.11	Refresh Control .....	171
6.5.12	Examples of Use.....	175
6.5.13	Usage Notes.....	179
6.6	Interval Timer.....	182
6.6.1	Operation.....	182
6.7	Interrupt Sources.....	187
6.8	Burst ROM Interface .....	187
6.8.1	Overview .....	187
6.8.2	Basic Timing .....	187
6.8.3	Wait Control .....	188
6.9	Idle Cycle.....	189
6.9.1	Operation.....	189
6.9.2	Pin States in Idle Cycle .....	192
6.10	Bus Arbiter .....	193
6.10.1	Operation.....	193

6.11	Register and Pin Input Timing .....	196
6.11.1	Register Write Timing.....	196
6.11.2	BREQ Pin Input Timing.....	197
<b>Section 7 DMA Controller.....</b>		<b>199</b>
7.1	Overview.....	199
7.1.1	Features .....	199
7.1.2	Block Diagram.....	200
7.1.3	Functional Overview .....	201
7.1.4	Input/Output Pins.....	202
7.1.5	Register Configuration .....	202
7.2	Register Descriptions (1) (Short Address Mode).....	204
7.2.1	Memory Address Registers (MAR).....	204
7.2.2	I/O Address Registers (IOAR) .....	205
7.2.3	Execute Transfer Count Registers (ETCR).....	205
7.2.4	Data Transfer Control Registers (DTCR) .....	207
7.3	Register Descriptions (2) (Full Address Mode) .....	210
7.3.1	Memory Address Registers (MAR).....	210
7.3.2	I/O Address Registers (IOAR) .....	210
7.3.3	Execute Transfer Count Registers (ETCR).....	211
7.3.4	Data Transfer Control Registers (DTCR) .....	213
7.4	Operation .....	219
7.4.1	Overview .....	219
7.4.2	I/O Mode .....	221
7.4.3	Idle Mode.....	223
7.4.4	Repeat Mode .....	226
7.4.5	Normal Mode.....	229
7.4.6	Block Transfer Mode.....	232
7.4.7	DMAC Activation .....	237
7.4.8	DMAC Bus Cycle .....	239
7.4.9	Multiple-Channel Operation .....	245
7.4.10	External Bus Requests, DRAM Interface, and DMAC.....	246
7.4.11	NMI Interrupts and DMAC.....	247
7.4.12	Aborting a DMAC Transfer .....	248
7.4.13	Exiting Full Address Mode .....	249
7.4.14	DMAC States in Reset State, Standby Modes, and Sleep Mode.....	250
7.5	Interrupts.....	251
7.6	Usage Notes .....	252
7.6.1	Note on Word Data Transfer .....	252
7.6.2	DMAC Self-Access.....	252
7.6.3	Longword Access to Memory Address Registers .....	252
7.6.4	Note on Full Address Mode Setup .....	252
7.6.5	Note on Activating DMAC by Internal Interrupts .....	253

7.6.6	NMI Interrupts and Block Transfer Mode.....	254
7.6.7	Memory and I/O Address Register Values .....	254
7.6.8	Bus Cycle when Transfer is Aborted.....	255
7.6.9	Transfer Requests by A/D Converter .....	255
Section 8	I/O Ports .....	257
8.1	Overview.....	257
8.2	Port 1.....	260
8.2.1	Overview .....	260
8.2.2	Register Descriptions.....	261
8.3	Port 2.....	263
8.3.1	Overview .....	263
8.3.2	Register Descriptions.....	264
8.4	Port 3.....	267
8.4.1	Overview .....	267
8.4.2	Register Descriptions .....	267
8.5	Port 4.....	269
8.5.1	Overview .....	269
8.5.2	Register Descriptions.....	270
8.6	Port 5.....	273
8.6.1	Overview .....	273
8.6.2	Register Descriptions.....	273
8.7	Port 6.....	277
8.7.1	Overview .....	277
8.7.2	Register Descriptions.....	278
8.8	Port 7.....	281
8.8.1	Overview .....	281
8.8.2	Register Description .....	282
8.9	Port 8.....	283
8.9.1	Overview .....	283
8.9.2	Register Descriptions.....	285
8.10	Port 9.....	289
8.10.1	Overview .....	289
8.10.2	Register Descriptions.....	290
8.11	Port A.....	294
8.11.1	Overview .....	294
8.11.2	Register Descriptions .....	296
8.12	Port B.....	305
8.12.1	Overview .....	305
8.12.2	Register Descriptions.....	307
Section 9	16-Bit Timer.....	315
9.1	Overview.....	315

9.1.1	Features .....	315
9.1.2	Block Diagrams .....	318
9.1.3	Input/Output Pins.....	321
9.1.4	Register Configuration .....	322
9.2	Register Descriptions.....	324
9.2.1	Timer Start Register (TSTR).....	324
9.2.2	Timer Synchro Register (TSNC).....	325
9.2.3	Timer Mode Register (TMDR) .....	326
9.2.4	Timer Interrupt Status Register A (TISRA) .....	328
9.2.5	Timer Interrupt Status Register B (TISRB).....	331
9.2.6	Timer Interrupt Status Register C (TISRC).....	334
9.2.7	Timer Counters (TCNT).....	336
9.2.8	General Registers (GRA, GRB) .....	337
9.2.9	Timer Control Registers (TCR).....	338
9.2.10	Timer I/O Control Register (TIOR) .....	340
9.2.11	Timer Output Level Setting Register C (TOLR).....	342
9.3	CPU Interface .....	345
9.3.1	16-Bit Accessible Registers.....	345
9.3.2	8-Bit Accessible Registers.....	347
9.4	Operation .....	348
9.4.1	Overview .....	348
9.4.2	Basic Functions .....	348
9.4.3	Synchronization.....	358
9.4.4	PWM Mode .....	360
9.4.5	Phase Counting Mode .....	364
9.4.6	Setting Initial Value of 16-Bit Timer Output .....	366
9.5	Interrupts.....	367
9.5.1	Setting of Status Flags.....	367
9.5.2	Timing of Clearing of Status Flags .....	369
9.5.3	Interrupt Sources and DMA Controller Activation.....	370
9.6	Usage Notes .....	371
<b>Section 10 8-Bit Timers .....</b>		<b>383</b>
10.1	Overview.....	383
10.1.1	Features .....	383
10.1.2	Block Diagram.....	385
10.1.3	Pin Configuration .....	386
10.1.4	Register Configuration .....	387
10.2	Register Descriptions.....	388
10.2.1	Timer Counters (TCNT).....	388
10.2.2	Time Constant Registers A (TCORA) .....	389
10.2.3	Time Constant Registers B (TCORB).....	390
10.2.4	Timer Control Register (TCR) .....	390

10.2.5	Timer Control/Status Registers (TCSR)	393
10.3	CPU Interface	397
10.3.1	8-Bit Registers	397
10.4	Operation	399
10.4.1	TCNT Count Timing	399
10.4.2	Compare Match Timing	400
10.4.3	Input Capture Signal Timing	401
10.4.4	Timing of Status Flag Setting	402
10.4.5	Operation with Cascaded Connection	403
10.4.6	Input Capture Setting	405
10.5	Interrupts	407
10.5.1	Interrupt Sources	407
10.5.2	A/D Converter Activation	408
10.6	8-Bit Timer Application Example	408
10.7	Usage Notes	409
10.7.1	Contention between TCNT Write and Clear	409
10.7.2	Contention between TCNT Write and Increment	410
10.7.3	Contention between TCOR Write and Compare Match	411
10.7.4	Contention between TCOR Read and Input Capture	412
10.7.5	Contention between Counter Clearing by Input Capture and Counter Increment	413
10.7.6	Contention between TCOR Write and Input Capture	414
10.7.7	Contention between TCNT Byte Write and Increment in 16-Bit Count Mode (Cascaded Connection)	415
10.7.8	Contention between Compare Matches A and B	416
10.7.9	TCNT Operation at Internal Clock Source Switchover	416
<b>Section 11 Programmable Timing Pattern Controller (TPC)</b>		<b>419</b>
11.1	Overview	419
11.1.1	Features	419
11.1.2	Block Diagram	420
11.1.3	TPC Pins	421
11.1.4	Registers	422
11.2	Register Descriptions	423
11.2.1	Port A Data Direction Register (PADDDR)	423
11.2.2	Port A Data Register (PADR)	423
11.2.3	Port B Data Direction Register (PBDDR)	424
11.2.4	Port B Data Register (PBDR)	424
11.2.5	Next Data Register A (NDRA)	425
11.2.6	Next Data Register B (NDRB)	427
11.2.7	Next Data Enable Register A (NDERA)	429
11.2.8	Next Data Enable Register B (NDERB)	430
11.2.9	TPC Output Control Register (TPCR)	431
11.2.10	TPC Output Mode Register (TPMR)	434

11.3	Operation .....	436
11.3.1	Overview .....	436
11.3.2	Output Timing .....	437
11.3.3	Normal TPC Output .....	438
11.3.4	Non-Overlapping TPC Output .....	440
11.3.5	TPC Output Triggering by Input Capture .....	442
11.4	Usage Notes .....	443
11.4.1	Operation of TPC Output Pins .....	443
11.4.2	Note on Non-Overlapping Output .....	443
<b>Section 12 Watchdog Timer .....</b>		<b>445</b>
12.1	Overview.....	445
12.1.1	Features .....	445
12.1.2	Block Diagram.....	446
12.1.3	Pin Configuration .....	446
12.1.4	Register Configuration .....	447
12.2	Register Descriptions.....	448
12.2.1	Timer Counter (TCNT) .....	448
12.2.2	Timer Control/Status Register (TCSR) .....	449
12.2.3	Reset Control/Status Register (RSTCSR) .....	451
12.2.4	Notes on Register Access .....	453
12.3	Operation .....	455
12.3.1	Watchdog Timer Operation.....	455
12.3.2	Interval Timer Operation.....	456
12.3.3	Timing of Setting of Overflow Flag (OVF) .....	457
12.3.4	Timing of Setting of Watchdog Timer Reset Bit (WRST) .....	458
12.4	Interrupts.....	459
12.5	Usage Notes .....	459
<b>Section 13 Serial Communication Interface .....</b>		<b>461</b>
13.1	Overview.....	461
13.1.1	Features .....	461
13.1.2	Block Diagram.....	463
13.1.3	Input/Output Pins.....	464
13.1.4	Register Configuration .....	465
13.2	Register Descriptions .....	466
13.2.1	Receive Shift Register (RSR).....	466
13.2.2	Receive Data Register (RDR) .....	466
13.2.3	Transmit Shift Register (TSR).....	467
13.2.4	Transmit Data Register (TDR).....	467
13.2.5	Serial Mode Register (SMR).....	468
13.2.6	Serial Control Register (SCR).....	472
13.2.7	Serial Status Register (SSR).....	476

13.2.8	Bit Rate Register (BRR).....	483
13.3	Operation .....	491
13.3.1	Overview .....	491
13.3.2	Operation in Asynchronous Mode.....	493
13.3.3	Multiprocessor Communication .....	503
13.3.4	Synchronous Operation .....	509
13.4	SCI Interrupts .....	518
13.5	Usage Notes .....	518
13.5.1	Notes on Use of SCI.....	518
<b>Section 14 Smart Card Interface.....</b>		<b>525</b>
14.1	Overview.....	525
14.1.1	Features .....	525
14.1.2	Block Diagram.....	526
14.1.3	Pin Configuration .....	526
14.1.4	Register Configuration .....	527
14.2	Register Descriptions.....	528
14.2.1	Smart Card Mode Register (SCMR).....	528
14.2.2	Serial Status Register (SSR).....	529
14.2.3	Serial Mode Register (SMR).....	531
14.2.4	Serial Control Register (SCR).....	532
14.3	Operation .....	532
14.3.1	Overview .....	532
14.3.2	Pin Connections.....	533
14.3.3	Data Format .....	534
14.3.4	Register Settings.....	535
14.3.5	Clock .....	537
14.3.6	Transmitting and Receiving Data.....	539
14.4	Usage Notes .....	547
<b>Section 15 A/D Converter .....</b>		<b>551</b>
15.1	Overview.....	551
15.1.1	Features .....	551
15.1.2	Block Diagram.....	552
15.1.3	Input Pins.....	553
15.1.4	Register Configuration .....	554
15.2	Register Descriptions.....	555
15.2.1	A/D Data Registers A to D (ADDRA to ADDRD).....	555
15.2.2	A/D Control/Status Register (ADCSR).....	556
15.2.3	A/D Control Register (ADCR).....	559
15.3	CPU Interface .....	560
15.4	Operation .....	561
15.4.1	Single Mode (SCAN = 0).....	561



15.4.2	Scan Mode (SCAN = 1) .....	563
15.4.3	Input Sampling and A/D Conversion Time.....	565
15.4.4	External Trigger Input Timing .....	566
15.5	Interrupts.....	567
15.6	Usage Notes .....	567
<b>Section 16 D/A Converter .....</b>		<b>573</b>
16.1	Overview.....	573
16.1.1	Features .....	573
16.1.2	Block Diagram.....	573
16.1.3	Input/Output Pins.....	574
16.1.4	Register Configuration .....	574
16.2	Register Descriptions.....	575
16.2.1	D/A Data Registers 0 and 1 (DADR0/1).....	575
16.2.2	D/A Control Register (DACR).....	575
16.2.3	D/A Standby Control Register (DASTCR).....	577
16.3	Operation .....	578
16.4	D/A Output Control .....	579
<b>Section 17 RAM.....</b>		<b>581</b>
17.1	Overview.....	581
17.1.1	Block Diagram.....	581
17.1.2	Register Configuration .....	582
17.2	System Control Register (SYSCR).....	583
17.3	Operation .....	584
<b>Section 18 ROM.....</b>		<b>585</b>
18.1	Overview.....	585
18.2	Overview of Flash Memory.....	586
18.2.1	Features .....	586
18.2.2	Block Diagram.....	587
18.2.3	Pin Configuration .....	588
18.2.4	Register Configuration .....	588
18.3	Register Descriptions .....	589
18.3.1	Flash Memory Control Register (FLMCR).....	589
18.3.2	Erase Block Register (EBR).....	593
18.3.3	RAM Control Register (RAMCR) .....	594
18.3.4	Flash Memory Status Register.....	596
18.4	On-Board Programming Modes .....	598
18.4.1	Boot Mode.....	601
18.4.2	User Program Mode .....	606
18.5	Programming/Erasing Flash Memory.....	608
18.5.1	Program Mode.....	609

18.5.2	Program-Verify Mode .....	610
18.5.3	Erase Mode .....	612
18.5.4	Erase-Verify Mode .....	612
18.6	Flash Memory Protection .....	614
18.6.1	Hardware Protection .....	614
18.6.2	Software Protection .....	616
18.6.3	Error Protection .....	616
18.6.4	NMI Input Disable Conditions .....	618
18.7	Flash Memory Emulation by RAM .....	619
18.8	Flash Memory PROM Mode .....	620
18.8.1	PROM Mode Setting .....	620
18.8.2	Memory Map .....	620
18.8.3	PROM Mode Operation .....	621
18.8.4	Memory Read Mode .....	623
18.8.5	Auto-Program Mode .....	626
18.8.6	Auto-Erase Mode .....	628
18.8.7	Status Read Mode .....	630
18.8.8	PROM Mode Transition Time .....	631
18.8.9	Notes On Memory Programming .....	632
18.9	Notes on Flash Memory Programming/Erasing .....	633
18.10	Mask ROM Overview .....	638
18.10.1	Block Diagram .....	638
18.11	Notes on Ordering Mask ROM Version Chip .....	639
<b>Section 19 Clock Pulse Generator .....</b>		<b>641</b>
19.1	Overview .....	641
19.1.1	Block Diagram .....	641
19.2	Oscillator Circuit .....	642
19.2.1	Connecting a Crystal Resonator .....	642
19.2.2	External Clock Input .....	644
19.3	Duty Adjustment Circuit .....	647
19.4	Prescalers .....	647
19.5	Frequency Divider .....	647
19.5.1	Register Configuration .....	647
19.5.2	Division Control Register (DIVCR) .....	647
19.5.3	Usage Notes .....	648
<b>Section 20 Power-Down State .....</b>		<b>649</b>
20.1	Overview .....	649
20.2	Register Configuration .....	651
20.2.1	System Control Register (SYSCR) .....	651
20.2.2	Module Standby Control Register H (MSTCRH) .....	653
20.2.3	Module Standby Control Register L (MSTCRL) .....	654

20.3	Sleep Mode.....	656
20.3.1	Transition to Sleep Mode .....	656
20.3.2	Exit from Sleep Mode .....	656
20.4	Software Standby Mode .....	657
20.4.1	Transition to Software Standby Mode.....	657
20.4.2	Exit from Software Standby Mode.....	657
20.4.3	Selection of Waiting Time for Exit from Software Standby Mode.....	658
20.4.4	Sample Application of Software Standby Mode.....	659
20.4.5	Note .....	659
20.4.6	Cautions on Clearing the Software Standby Mode of F-ZTAT Version.....	660
20.5	Hardware Standby Mode .....	661
20.5.1	Transition to Hardware Standby Mode .....	661
20.5.2	Exit from Hardware Standby Mode .....	661
20.5.3	Timing for Hardware Standby Mode .....	661
20.6	Module Standby Function.....	662
20.6.1	Module Standby Timing.....	662
20.6.2	Read/Write in Module Standby .....	662
20.6.3	Usage Notes.....	662
20.7	System Clock Output Disabling Function .....	663
<b>Section 21 Electrical Characteristics.....</b>		<b>665</b>
21.1	Electrical Characteristics of Mask ROM Version .....	665
21.1.1	Absolute Maximum Ratings.....	665
21.1.2	DC Characteristics.....	666
21.1.3	AC Characteristics.....	677
21.1.4	A/D Conversion Characteristics .....	686
21.1.5	D/A Conversion Characteristics .....	688
21.2	Electrical Characteristics of Flash Memory and Flash Memory R Versions .....	689
21.2.1	Absolute Maximum Ratings .....	689
21.2.2	DC Characteristics.....	690
21.2.3	AC Characteristics.....	698
21.2.4	A/D Conversion Characteristics .....	707
21.2.5	D/A Conversion Characteristics .....	709
21.2.6	Flash Memory Characteristics.....	710
21.3	Operational Timing.....	712
21.3.1	Clock Timing.....	712
21.3.2	Control Signal Timing.....	713
21.3.3	Bus Timing .....	715
21.3.4	DRAM Interface Bus Timing .....	721
21.3.5	TPC and I/O Port Timing .....	724
21.3.6	Timer Input/Output Timing.....	725
21.3.7	SCI Input/Output Timing .....	726
21.3.8	DMAC Timing .....	727

Appendix A	Instruction Set .....	729
A.1	Instruction List.....	729
A.2	Operation Code Maps.....	744
A.3	Number of States Required for Execution .....	747
Appendix B	Internal I/O Registers.....	756
B.1	Addresses.....	756
B.2	Functions.....	767
Appendix C	I/O Port Block Diagrams .....	860
C.1	Port 1 Block Diagram.....	860
C.2	Port 2 Block Diagram.....	861
C.3	Port 3 Block Diagram.....	862
C.4	Port 4 Block Diagram.....	863
C.5	Port 5 Block Diagram.....	864
C.6	Port 6 Block Diagrams .....	865
C.7	Port 7 Block Diagrams .....	872
C.8	Port 8 Block Diagrams .....	873
C.9	Port 9 Block Diagrams .....	878
C.10	Port A Block Diagrams.....	884
C.11	Port B Block Diagrams.....	887
Appendix D	Pin States .....	895
D.1	Port States in Each Mode .....	895
D.2	Pin States at Reset.....	902
Appendix E	Timing of Transition to and Recovery from Hardware Standby Mode .....	905
Appendix F	Product Code Lineup .....	906
Appendix G	Package Dimensions .....	907
Appendix H	Comparison of H8/300H Series Product Specifications .....	910
H.1	Differences between H8/3067 and H8/3062 Series, H8/3048 Series, H8/3007 and H8/3006, and H8/3002.....	910
H.2	Comparison of Pin Functions of 100-Pin Package Products (FP-100B, TFP-100B).....	913

# Section 1 Overview

## 1.1 Overview

The H8/3067 Series is a series of microcontrollers (MCUs) that integrate system supporting functions together with an H8/300H CPU core having an original Hitachi architecture.

The H8/300H CPU has a 32-bit internal architecture with sixteen 16-bit general registers, and a concise, optimized instruction set designed for speed. It can address a 16-Mbyte linear address space. Its instruction set is upward-compatible at the object-code level with the H8/300 CPU, enabling easy porting of software from the H8/300 Series.

The on-chip system supporting functions include ROM, RAM, a 16-bit timer, an 8-bit timer, a programmable timing pattern controller (TPC), a watchdog timer (WDT), a serial communication interface (SCI), an A/D converter, a D/A converter, I/O ports, a direct memory access controller (DMAC), and other facilities.

The three members of the H8/3067 Series are the H8/3067, the H8/3066, and the H8/3065. The H8/3067 has 128 kbytes of ROM and 4 kbytes of RAM. The H8/3066 has 96 kbytes of ROM and 4 kbytes of RAM. The H8/3065 has 64 kbytes of ROM and 2 kbytes of RAM.

Seven MCU operating modes offer a choice of bus width and address space size. The modes (modes 1 to 7) include two single-chip modes and five expanded modes.

In addition to the mask ROM versions, the H8/3067 Series includes an F-ZTAT™\* version with on-chip flash memory that can be programmed on-board. This version enables users to respond quickly and flexibly to changing application specifications, growing production volumes, and other conditions.

Table 1.1 summarizes the features of the H8/3067 Series.

Note: \* F-ZTAT™ (Flexible ZTAT) is a trademark of Hitachi, Ltd.

**Table 1.1 Features**

Feature	Description
CPU	<p>Upward-compatible with the H8/300 CPU at the object-code level General-register machine</p> <ul style="list-style-type: none"> <li>• Sixteen 16-bit general registers (also usable as sixteen 8-bit registers or eight 32-bit registers)</li> </ul> <p>High-speed operation</p> <ul style="list-style-type: none"> <li>• Maximum clock rate: 20 MHz</li> <li>• Add/subtract: 100 ns</li> <li>• Multiply/divide: 700 ns</li> </ul> <p>16-Mbyte address space</p> <p>Instruction features</p> <ul style="list-style-type: none"> <li>• 8/16/32-bit data transfer, arithmetic, and logic instructions</li> <li>• Signed and unsigned multiply instructions (8 bits x 8 bits, 16 bits x 16 bits)</li> <li>• Signed and unsigned divide instructions (16 bits ÷ 8 bits, 32 bits ÷ 16 bits)</li> <li>• Bit accumulator function</li> <li>• Bit manipulation instructions with register-indirect specification of bit positions</li> </ul>
Memory	<p>H8/3067</p> <ul style="list-style-type: none"> <li>• ROM: 128 kbytes</li> <li>• RAM: 4 kbytes</li> </ul> <p>H8/3066</p> <ul style="list-style-type: none"> <li>• ROM: 96 kbytes</li> <li>• RAM: 4 kbytes</li> </ul> <p>H8/3065</p> <ul style="list-style-type: none"> <li>• ROM: 64 kbytes</li> <li>• RAM: 2 kbytes</li> </ul>
Interrupt controller	<ul style="list-style-type: none"> <li>• Seven external interrupt pins: NMI, <math>\overline{IRQ}_0</math> to <math>\overline{IRQ}_6</math></li> <li>• 36 internal interrupts</li> <li>• Three selectable interrupt priority levels</li> </ul>
Bus controller	<ul style="list-style-type: none"> <li>• Address space can be partitioned into eight areas, with independent bus specifications in each area</li> <li>• Chip select output available for areas 0 to 7</li> <li>• 8-bit access or 16-bit access selectable for each area</li> <li>• Two-state or three-state access selectable for each area</li> <li>• Selection of two wait modes</li> <li>• Number of program wait states selectable for each area</li> <li>• Direct connection of burst ROM</li> <li>• Direct connection of up to 8-Mbyte DRAM (or DRAM interface can be used as interval timer)</li> <li>• Bus arbitration function</li> </ul>

**Table 1.1 Features**

<b>Feature</b>	<b>Description</b>
DMA controller (DMAC)	<p>Short address mode</p> <ul style="list-style-type: none"> <li>• Maximum four channels available</li> <li>• Selection of I/O mode, idle mode, or repeat mode</li> <li>• Can be activated by compare match/input capture A interrupts from 16-bit timer channels 0 to 2, conversion-end interrupts from the A/D converter, transmit-data-empty and receive-data-full interrupts from the SCI, or external requests</li> </ul> <p>Full address mode</p> <ul style="list-style-type: none"> <li>• Maximum two channels available</li> <li>• Selection of normal mode or block transfer mode</li> <li>• Can be activated by compare match/input capture A interrupts from 16-bit timer channels 0 to 2, conversion-end interrupts from the A/D converter, external requests, or auto-request</li> </ul>
16-bit timer, 3 channels	<ul style="list-style-type: none"> <li>• Three 16-bit timer channels, capable of processing up to six pulse outputs or six pulse inputs</li> <li>• 16-bit timer counter (channels 0 to 2)</li> <li>• Two multiplexed output compare/input capture pins (channels 0 to 2)</li> <li>• Operation can be synchronized (channels 0 to 2)</li> <li>• PWM mode available (channels 0 to 2)</li> <li>• Phase counting mode available (channel 2)</li> <li>• DMAC can be activated by compare match/input capture A interrupts (channels 0 to 2)</li> </ul>
8-bit timer, 4 channels	<ul style="list-style-type: none"> <li>• 8-bit up-counter (external event count capability)</li> <li>• Two time constant registers</li> <li>• Two channels can be connected</li> </ul>
Programmable timing pattern controller (TPC)	<ul style="list-style-type: none"> <li>• Maximum 16-bit pulse output, using 16-bit timer as time base</li> <li>• Up to four 4-bit pulse output groups (or one 16-bit group, or two 8-bit groups)</li> <li>• Non-overlap mode available</li> <li>• Output data can be transferred by DMAC</li> </ul>
Watchdog timer (WDT), 1 channel	<ul style="list-style-type: none"> <li>• Reset signal can be generated by overflow</li> <li>• Reset signal can be output externally (not in the F-ZTAT version)</li> <li>• Usable as an interval timer</li> </ul>
Serial communication interface (SCI), 3 channels	<ul style="list-style-type: none"> <li>• Selection of asynchronous or synchronous mode</li> <li>• Full duplex: can transmit and receive simultaneously</li> <li>• On-chip baud-rate generator</li> <li>• Smart card interface functions added</li> </ul>

**Table 1.1 Features (cont)**

<b>Feature</b>	<b>Description</b>																																								
A/D converter	<ul style="list-style-type: none"> <li>Resolution: 10 bits</li> <li>Eight channels, with selection of single or scan mode</li> <li>Variable analog conversion voltage range</li> <li>Sample-and-hold function</li> <li>A/D conversion can be started by an external trigger or 8-bit timer compare-match</li> <li>DMAC can be activated by an A/D conversion end interrupt</li> </ul>																																								
D/A converter	<ul style="list-style-type: none"> <li>Resolution: 8 bits</li> <li>Two channels</li> <li>D/A outputs can be sustained in software standby mode</li> </ul>																																								
I/O ports	<ul style="list-style-type: none"> <li>70 input/output pins</li> <li>9 input-only pins</li> </ul>																																								
Operating modes	<p>Seven MCU operating modes</p> <table border="1"> <thead> <tr> <th><b>Mode</b></th> <th><b>Address Space</b></th> <th><b>Address Pins</b></th> <th><b>Initial Bus Width</b></th> <th><b>Max. Bus Width</b></th> </tr> </thead> <tbody> <tr> <td>Mode 1</td> <td>1 Mbyte</td> <td>A<sub>19</sub> to A<sub>0</sub></td> <td>8 bits</td> <td>16 bits</td> </tr> <tr> <td>Mode 2</td> <td>1 Mbyte</td> <td>A<sub>19</sub> to A<sub>0</sub></td> <td>16 bits</td> <td>16 bits</td> </tr> <tr> <td>Mode 3</td> <td>16 Mbytes</td> <td>A<sub>23</sub> to A<sub>0</sub></td> <td>8 bits</td> <td>16 bits</td> </tr> <tr> <td>Mode 4</td> <td>16 Mbytes</td> <td>A<sub>23</sub> to A<sub>0</sub></td> <td>16 bits</td> <td>16 bits</td> </tr> <tr> <td>Mode 5</td> <td>16 Mbytes</td> <td>A<sub>23</sub> to A<sub>0</sub></td> <td>8 bits</td> <td>16 bits</td> </tr> <tr> <td>Mode 6</td> <td>64 kbyte</td> <td>—</td> <td>—</td> <td>—</td> </tr> <tr> <td>Mode 7</td> <td>1 Mbyte</td> <td>—</td> <td>—</td> <td>—</td> </tr> </tbody> </table> <ul style="list-style-type: none"> <li>On-chip ROM is disabled in modes 1 to 4</li> </ul>	<b>Mode</b>	<b>Address Space</b>	<b>Address Pins</b>	<b>Initial Bus Width</b>	<b>Max. Bus Width</b>	Mode 1	1 Mbyte	A <sub>19</sub> to A <sub>0</sub>	8 bits	16 bits	Mode 2	1 Mbyte	A <sub>19</sub> to A <sub>0</sub>	16 bits	16 bits	Mode 3	16 Mbytes	A <sub>23</sub> to A <sub>0</sub>	8 bits	16 bits	Mode 4	16 Mbytes	A <sub>23</sub> to A <sub>0</sub>	16 bits	16 bits	Mode 5	16 Mbytes	A <sub>23</sub> to A <sub>0</sub>	8 bits	16 bits	Mode 6	64 kbyte	—	—	—	Mode 7	1 Mbyte	—	—	—
<b>Mode</b>	<b>Address Space</b>	<b>Address Pins</b>	<b>Initial Bus Width</b>	<b>Max. Bus Width</b>																																					
Mode 1	1 Mbyte	A <sub>19</sub> to A <sub>0</sub>	8 bits	16 bits																																					
Mode 2	1 Mbyte	A <sub>19</sub> to A <sub>0</sub>	16 bits	16 bits																																					
Mode 3	16 Mbytes	A <sub>23</sub> to A <sub>0</sub>	8 bits	16 bits																																					
Mode 4	16 Mbytes	A <sub>23</sub> to A <sub>0</sub>	16 bits	16 bits																																					
Mode 5	16 Mbytes	A <sub>23</sub> to A <sub>0</sub>	8 bits	16 bits																																					
Mode 6	64 kbyte	—	—	—																																					
Mode 7	1 Mbyte	—	—	—																																					
Power-down state	<ul style="list-style-type: none"> <li>Sleep mode</li> <li>Software standby mode</li> <li>Hardware standby mode</li> <li>Module standby function</li> <li>Programmable system clock frequency division</li> </ul>																																								
Other features	<ul style="list-style-type: none"> <li>On-chip clock pulse generator</li> </ul>																																								



**Table 1.1 Features (cont)**

<b>Feature</b>	<b>Description</b>				
Product lineup	<b>Product Type</b>		<b>Product Code</b>	<b>Package</b>	
H8/3067	On-chip flash memory	5 V	HD64F3067F	100-pin QFP (FP-100B)	
			HD64F3067TE	100-pin TQFP (TFP-100B)	
			HD64F3067FP	100-pin QFP (FP-100A)	
		5 VR	HD64F3067RF	100-pin QFP (FP-100B)	
			HD64F3067RTE	100-pin TQFP (TFP-100B)	
			HD64F3067RFP	100-pin QFP (FP-100A)	
		3 VR	HD64F3067RVF	100-pin QFP (FP-100B)	
			HD64F3067RVTE	100-pin TQFP (TFP-100B)	
			HD64F3067RVFP	100-pin QFP (FP-100A)	
	On-chip mask ROM	5 V	HD6433067F	100-pin QFP (FP-100B)	
			HD6433067TE	100-pin TQFP (TFP-100B)	
			HD6433067FP	100-pin QFP (FP-100A)	
		3 V	HD6433067VF	100-pin QFP (FP-100B)	
			HD6433067VTE	100-pin TQFP (TFP-100B)	
			HD6433067VFP	100-pin QFP (FP-100A)	
	H8/3066	On-chip mask ROM	5 V	HD6433066F	100-pin QFP (FP-100B)
				HD6433066TE	100-pin TQFP (TFP-100B)
				HD6433066FP	100-pin QFP (FP-100A)
3 V			HD6433066VF	100-pin QFP (FP-100B)	
			HD6433066VTE	100-pin TQFP (TFP-100B)	
			HD6433066VFP	100-pin QFP (FP-100A)	
H8/3065	Mask ROM version	5 V	HD6433065F	100-pin QFP (FP-100B)	
			HD6433065TE	100-pin TQFP (TFP-100B)	
			HD6433065FP	100-pin QFP (FP-100A)	
		3 V	HD6433065VF	100-pin QFP (FP-100B)	
			HD6433065VTE	100-pin TQFP (TFP-100B)	
			HD6433065VFP	100-pin QFP (FP-100A)	

# 1.2 Block Diagram

Figure 1.1 shows an internal block diagram.

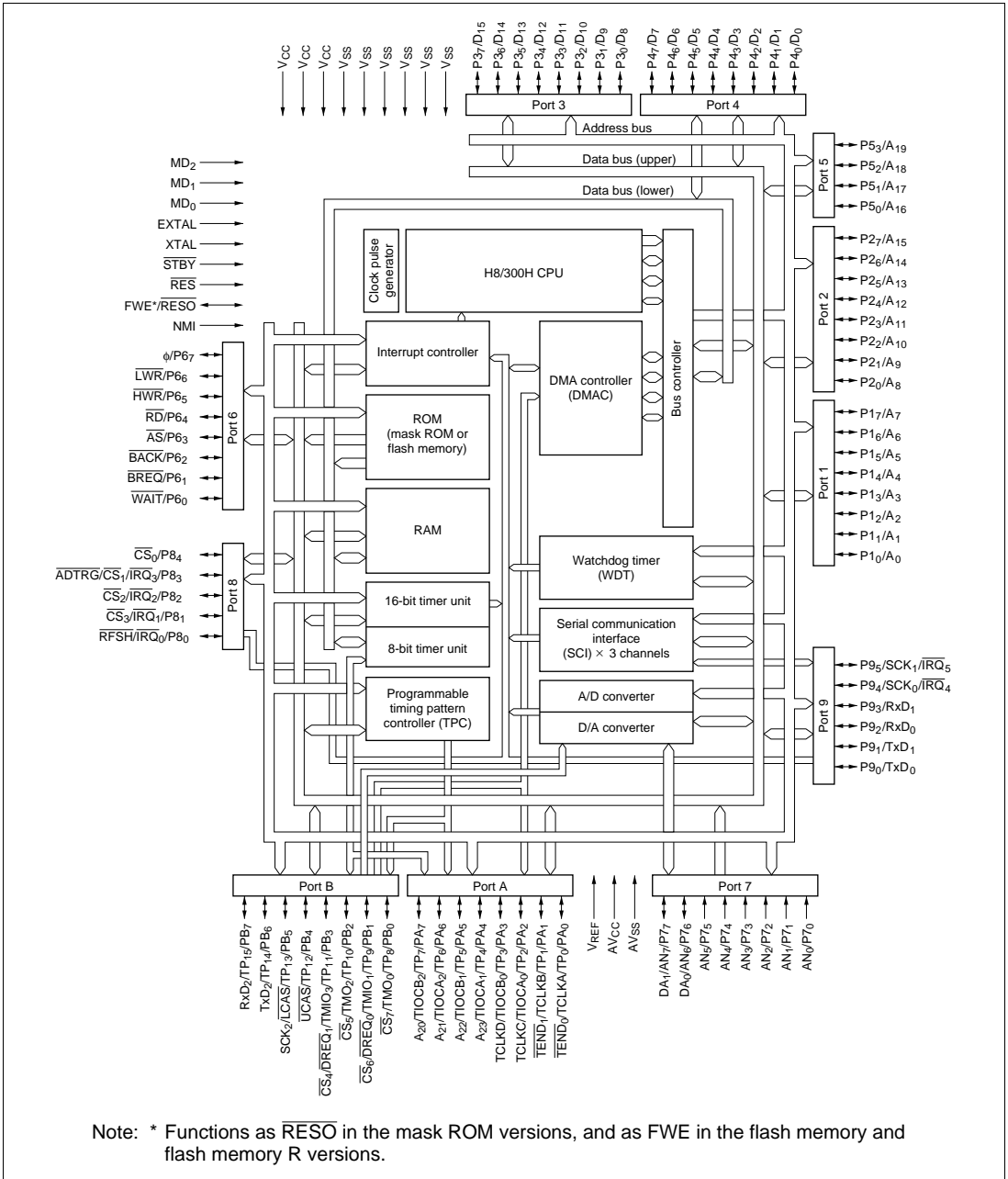


Figure 1.1 Block Diagram

# 1.3 Pin Description

## 1.3.1 Pin Arrangement

The pin arrangement of the H8/3067 Series FP-100B and TFP-100B packages is shown in figure 1.2, and that of the FP-100A package in figure 1.3.

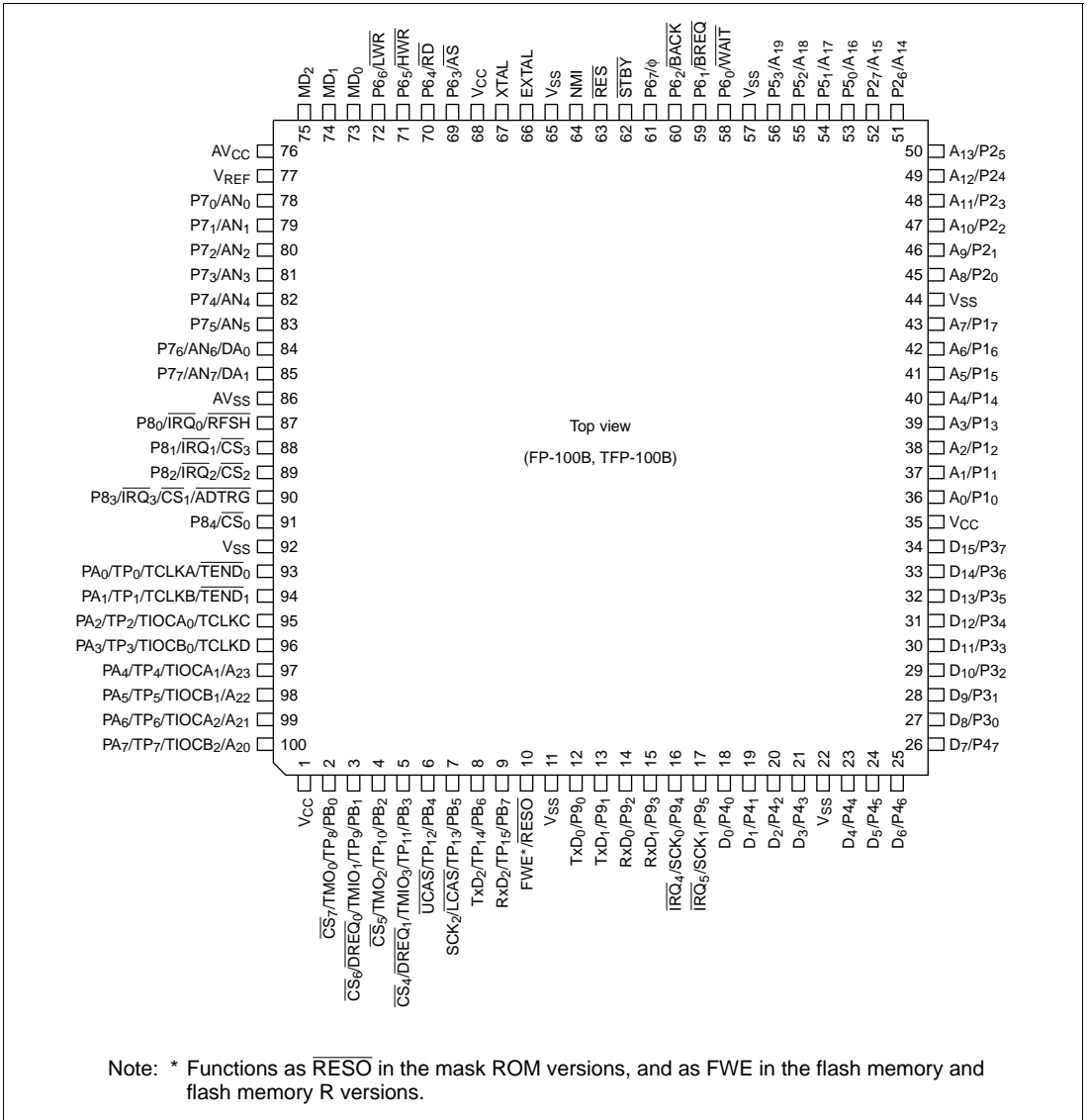
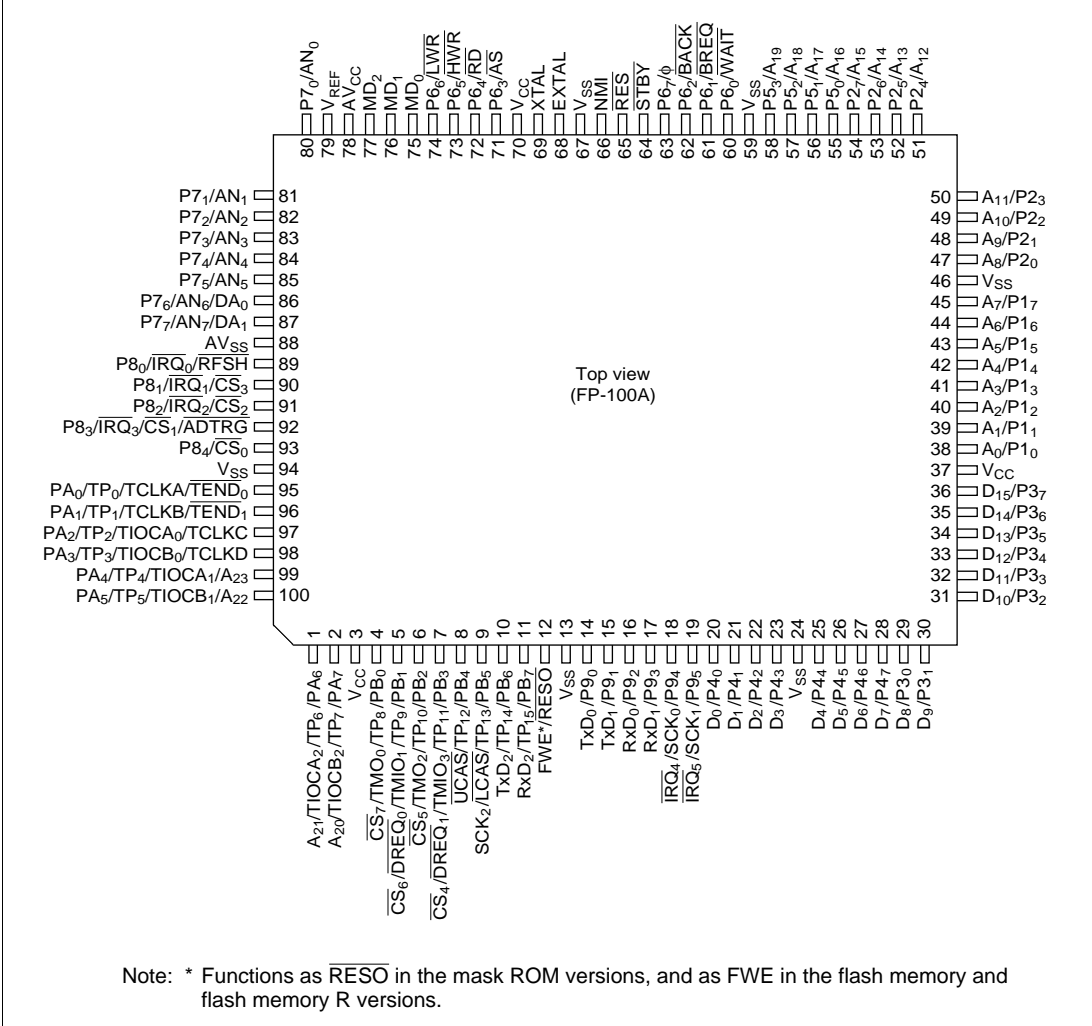


Figure 1.2 Pin Arrangement (FP-100B or TFP-100B, Top View)



**Figure 1.3 Pin Arrangement (FP-100A, Top View)**

### 1.3.2 Pin Functions

Table 1.2 summarizes the pin functions.

**Table 1.2 Pin Functions**

Type	Symbol	Pin No.		I/O	Name and Function																																				
		FP-100B TFP-100B	FP-100A																																						
Power	$V_{CC}$	1, 35, 68	3, 37, 70	Input	<b>Power:</b> For connection to the power supply. Connect all $V_{CC}$ pins to the system power supply.																																				
	$V_{SS}$	11, 22, 44, 57, 65, 92	13, 24, 46, 59, 67, 94	Input	<b>Ground:</b> For connection to ground (0 V). Connect all $V_{SS}$ pins to the 0-V system power supply.																																				
Clock	XTAL	67	69	Input	For connection to a crystal resonator. For examples of crystal resonator and external clock input, see section 19, Clock Pulse Generator.																																				
	EXTAL	66	68	Input	For connection to a crystal resonator or input of an external clock signal. For examples of crystal resonator and external clock input, see section 19, Clock Pulse Generator.																																				
	$\phi$	61	63	Output	<b>System clock:</b> Supplies the system clock to external devices.																																				
Operating mode control	$MD_2$ to $MD_0$	75 to 73	77 to 75	Input	<b>Mode 2 to mode 0:</b> For setting the operating mode, as follows. Inputs at these pins must not be changed during operation.																																				
		<table border="1"> <thead> <tr> <th><math>MD_2</math></th> <th><math>MD_1</math></th> <th><math>MD_0</math></th> <th>Operating Mode</th> </tr> </thead> <tbody> <tr> <td>0</td> <td>0</td> <td>0</td> <td>—</td> </tr> <tr> <td>0</td> <td>0</td> <td>1</td> <td>Mode 1</td> </tr> <tr> <td>0</td> <td>1</td> <td>0</td> <td>Mode 2</td> </tr> <tr> <td>0</td> <td>1</td> <td>1</td> <td>Mode 3</td> </tr> <tr> <td>1</td> <td>0</td> <td>0</td> <td>Mode 4</td> </tr> <tr> <td>1</td> <td>0</td> <td>1</td> <td>Mode 5</td> </tr> <tr> <td>1</td> <td>1</td> <td>0</td> <td>Mode 6</td> </tr> <tr> <td>1</td> <td>1</td> <td>1</td> <td>Mode 7</td> </tr> </tbody> </table>				$MD_2$	$MD_1$	$MD_0$	Operating Mode	0	0	0	—	0	0	1	Mode 1	0	1	0	Mode 2	0	1	1	Mode 3	1	0	0	Mode 4	1	0	1	Mode 5	1	1	0	Mode 6	1	1	1	Mode 7
		$MD_2$	$MD_1$	$MD_0$	Operating Mode																																				
		0	0	0	—																																				
		0	0	1	Mode 1																																				
		0	1	0	Mode 2																																				
		0	1	1	Mode 3																																				
		1	0	0	Mode 4																																				
		1	0	1	Mode 5																																				
		1	1	0	Mode 6																																				
1	1	1	Mode 7																																						

**Table 1.2 Pin Functions (cont)**

Type	Symbol	Pin No.		I/O	Name and Function
		FP-100B	TFP-100B FP-100A		
System control	$\overline{\text{RES}}$	63	65	Input	<b>Reset input:</b> When driven low, this pin resets the chip
	$\overline{\text{RESO}}$	10	12	Output	<b>Reset output (Mask ROM version):</b> Outputs the reset signal generated by the watchdog timer to external devices
	FWE	10	12	Input	<b>Write enable signal (Flash memory and flash memory R versions):</b> Flash memory write control signal
	$\overline{\text{STBY}}$	62	64	Input	<b>Standby:</b> When driven low, this pin forces a transition to hardware standby mode
	$\overline{\text{BREQ}}$	59	61	Input	<b>Bus request:</b> Used by an external bus master to request the bus right
	$\overline{\text{BACK}}$	60	62	Output	<b>Bus request acknowledge:</b> Indicates that the bus has been granted to an external bus master
Interrupts	NMI	64	66	Input	<b>Nonmaskable interrupt:</b> Requests a nonmaskable interrupt
	$\overline{\text{IRQ}}_5$ to $\overline{\text{IRQ}}_0$	17, 16, 90 to 87	19, 18, 92 to 89	Input	<b>Interrupt request 5 to 0:</b> Maskable interrupt request pins
Address bus	$A_{23}$ to $A_0$	97 to 100, 56 to 45, 43 to 36	99, 100, 1, 2, 58 to 47, 45 to 38	Output	<b>Address bus:</b> Outputs address signals
Data bus	$D_{15}$ to $D_0$	34 to 23, 21 to 18	36 to 25, 23 to 20	Input/output	<b>Data bus:</b> Bidirectional data bus
Bus control	$\overline{\text{CS}}_7$ to $\overline{\text{CS}}_0$	2 to 5, 88 to 91	4 to 7, 90 to 93	Output	<b>Chip select:</b> Select signals for areas 7 to 0
	$\overline{\text{AS}}$	69	71	Output	<b>Address strobe:</b> Goes low to indicate valid address output on the address bus
	$\overline{\text{RD}}$	70	72	Output	<b>Read:</b> Goes low to indicate reading from the external address space
	$\overline{\text{HWR}}$	71	73	Output	<b>High write:</b> Goes low to indicate writing to the external address space; indicates valid data on the upper data bus ( $D_{15}$ to $D_8$ ).

**Table 1.2 Pin Functions (cont)**

Type	Symbol	Pin No.		I/O	Name and Function
		FP-100B	TFP-100B FP-100A		
Bus control	$\overline{\text{LWR}}$	72	74	Output	<b>Low write:</b> Goes low to indicate writing to the external address space; indicates valid data on the lower data bus ( $D_7$ to $D_0$ ).
	$\overline{\text{WAIT}}$	58	60	Input	<b>Wait:</b> Requests insertion of wait states in bus cycles during access to the external address space
DRAM interface	$\overline{\text{RFSH}}$	87	89	Output	<b>Refresh:</b> Indicates a refresh cycle
	$\overline{\text{CS}}_2$ to $\overline{\text{CS}}_5$	89, 88, 5, 4	91, 90, 7, 6	Output	<b>Row address strobe <math>\overline{\text{RAS}}</math>:</b> Row address strobe signal for DRAM
	$\overline{\text{RD}}$	70	72	Output	<b>Write enable <math>\overline{\text{WE}}</math>:</b> Write enable signal for DRAM
	$\overline{\text{HWR}}$ $\overline{\text{UCAS}}$	71 6	73 8	Output	<b>Upper column address strobe <math>\overline{\text{UCAS}}</math>:</b> Column address strobe signal for DRAM
	$\overline{\text{LWR}}$ $\overline{\text{LCAS}}$	72 7	74 9	Output	<b>Lower column address strobe <math>\overline{\text{LCAS}}</math>:</b> Column address strobe signal for DRAM
DMA controller (DMAC)	$\overline{\text{DREQ}}_1$ , $\overline{\text{DREQ}}_0$	5, 3	7, 5	Input	<b>DMA request 1 and 0:</b> DMAC activation requests
	$\overline{\text{TEND}}_1$ , $\overline{\text{TEND}}_0$	94, 93	96, 95	Output	<b>Transfer end 1 and 0:</b> These signals indicate that the DMAC has ended a data transfer
16-bit timer	TCLKD to TCLKA	96 to 93	98 to 95	Input	<b>Clock input D to A:</b> External clock inputs
	TIOCA <sub>2</sub> to TIOCA <sub>0</sub>	99, 97, 95	1, 99, 97	Input/output	<b>Input capture/output compare A2 to A0:</b> GRA2 to GRA0 output compare or input capture, or PWM output
	TIOCB <sub>2</sub> to TIOCB <sub>0</sub>	100, 98, 96	2, 100, 98	Input/output	<b>Input capture/output compare B2 to B0:</b> GRB2 to GRB0 output compare or input capture, or PWM output
8-bit timer	TMO <sub>0</sub> , TMO <sub>2</sub>	2, 4	4, 6	Output	<b>Compare match output:</b> Compare match output pins
	TMIO <sub>1</sub> , TMIO <sub>3</sub>	3, 5	5, 7	Input/output	<b>Input capture input/compare match output:</b> Input capture input or compare match output pins
	TCLKD to TCLKA	96 to 93	98 to 95	Input	<b>Counter external clock input:</b> These pins input an external clock to the counters.

**Table 1.2 Pin Functions (cont)**

Type	Symbol	Pin No.		I/O	Name and Function
		FP-100B	FP-100A		
Program- mable timing pattern controller (TPC)	TP <sub>15</sub> to TP <sub>0</sub>	9 to 2, 100 to 93	11 to 4, 2, 1, 100 to 95	Output	<b>TPC output 15 to 0:</b> Pulse output
Serial communi- cation interface (SCI)	TxD <sub>2</sub> to TxD <sub>0</sub>	8, 13, 12	10, 15, 14	Output	<b>Transmit data (channels 0, 1, 2):</b> SCI data output
	RxD <sub>2</sub> to RxD <sub>0</sub>	9, 15, 14	11, 17, 16	Input	<b>Receive data (channels 0, 1, 2):</b> SCI data input
	SCK <sub>2</sub> to SCK <sub>0</sub>	7, 17, 16	9, 19, 18	Input/ output	<b>Serial clock (channels 0, 1, 2):</b> SCI clock input/output
A/D converter	AN <sub>7</sub> to AN <sub>0</sub>	85 to 78	87 to 80	Input	<b>Analog 7 to 0:</b> Analog input pins
	ADTRG	90	92	Input	<b>A/D conversion external trigger input:</b> External trigger input for starting A/D conversion
D/A converter	DA <sub>11</sub> , DA <sub>0</sub>	85, 84	87, 86	Output	<b>Analog output:</b> Analog output from the D/A converter
A/D and D/A converters	AV <sub>CC</sub>	76	78	Input	Power supply pin for the A/D and D/A converters. Connect to the system power supply when not using the A/D and D/A converters.
	AV <sub>SS</sub>	86	88	Input	Ground pin for the A/D and D/A converters. Connect to system ground (0 V).
	V <sub>REF</sub>	77	79	Input	Reference voltage input pin for the A/D and D/A converters. Connect to the system power supply when not using the A/D and D/A converters.
I/O ports	P1 <sub>7</sub> to P1 <sub>0</sub>	43 to 36	45 to 38	Input/ output	<b>Port 1:</b> Eight input/output pins. The direction of each pin can be selected in the port 1 data direction register (P1DDR).
	P2 <sub>7</sub> to P2 <sub>0</sub>	52 to 45	54 to 47	Input/ output	<b>Port 2:</b> Eight input/output pins. The direction of each pin can be selected in the port 2 data direction register (P2DDR).
	P3 <sub>7</sub> to P3 <sub>0</sub>	34 to 27	36 to 29	Input/ output	<b>Port 3:</b> Eight input/output pins. The direction of each pin can be selected in the port 3 data direction register (P3DDR).



**Table 1.2 Pin Functions (cont)**

Type	Symbol	Pin No.		I/O	Name and Function
		FP-100B	TFP-100B FP-100A		
I/O ports	P4 <sub>7</sub> to P4 <sub>0</sub>	26 to 23, 21 to 18	28 to 25, 23 to 20	Input/ output	<b>Port 4:</b> Eight input/output pins. The direction of each pin can be selected in the port 4 data direction register (P4DDR).
	P5 <sub>3</sub> to P5 <sub>0</sub>	56 to 53	58 to 55	Input/ output	<b>Port 5:</b> Four input/output pins. The direction of each pin can be selected in the port 5 data direction register (P5DDR).
	P6 <sub>7</sub> to P6 <sub>0</sub>	61, 72 to 69, 60 to 58	63, 74 to 71, 62 to 60	Input/ output	<b>Port 6:</b> Eight input/output pins. The direction of each pin can be selected in the port 6 data direction register (P6DDR).
	P7 <sub>7</sub> to P7 <sub>0</sub>	85 to 78	87 to 80	Input	<b>Port 7:</b> Eight input pins
	P8 <sub>4</sub> to P8 <sub>0</sub>	91 to 87	93 to 89	Input/ output	<b>Port 8:</b> Five input/output pins. The direction of each pin can be selected in the port 8 data direction register (P8DDR).
	P9 <sub>5</sub> to P9 <sub>0</sub>	17 to 12	19 to 14	Input/ output	<b>Port 9:</b> Six input/output pins. The direction of each pin can be selected in the port 9 data direction register (P9DDR).
	PA <sub>7</sub> to PA <sub>0</sub>	100 to 93	2, 1, 100 to 95	Input/ output	<b>Port A:</b> Eight input/output pins. The direction of each pin can be selected in the port A data direction register (PADDDR).
	PB <sub>7</sub> to PB <sub>0</sub>	9 to 2	11 to 4	Input/ output	<b>Port B:</b> Eight input/output pins. The direction of each pin can be selected in the port B data direction register (PBDDR).

### 1.3.3 Pin Assignments in Each Mode

Table 1.3 lists the pin assignments in each mode.

**Table 1.3 Pin Assignments in Each Mode (FP-100B or TFP-100B, FP-100A)**

Pin No.		Pin name							
FP-100B	TFP-100B	FP-100A	Mode 1	Mode 2	Mode 3	Mode 4	Mode 5	Mode 6	Mode 7
1	3		V <sub>CC</sub>	V <sub>CC</sub>	V <sub>CC</sub>	V <sub>CC</sub>	V <sub>CC</sub>	V <sub>CC</sub>	V <sub>CC</sub>
2	4		PB <sub>7</sub> /TP <sub>7</sub> / TMO <sub>7</sub> /CS <sub>7</sub>	PB <sub>7</sub> /TP <sub>7</sub> / TMO <sub>7</sub> /CS <sub>7</sub>	PB <sub>7</sub> /TP <sub>7</sub> / TMO <sub>7</sub> /CS <sub>7</sub>	PB <sub>7</sub> /TP <sub>7</sub> / TMO <sub>7</sub> /CS <sub>7</sub>	PB <sub>7</sub> /TP <sub>7</sub> / TMO <sub>7</sub> /CS <sub>7</sub>	PB <sub>7</sub> /TP <sub>7</sub> / TMO <sub>0</sub>	PB <sub>7</sub> /TP <sub>7</sub> / TMO <sub>0</sub>
3	5		PB <sub>7</sub> /TP <sub>9</sub> / TMIO <sub>1</sub> / /DREQ <sub>1</sub> /CS <sub>6</sub>	PB <sub>7</sub> /TP <sub>9</sub> / TMIO <sub>1</sub> / /DREQ <sub>1</sub> /CS <sub>6</sub>	PB <sub>7</sub> /TP <sub>9</sub> / TMIO <sub>1</sub> / /DREQ <sub>1</sub> /CS <sub>6</sub>	PB <sub>7</sub> /TP <sub>9</sub> / TMIO <sub>1</sub> / /DREQ <sub>1</sub> /CS <sub>6</sub>	PB <sub>7</sub> /TP <sub>9</sub> / TMIO <sub>1</sub> / DREQ <sub>1</sub> /CS <sub>6</sub>	PB <sub>7</sub> /TP <sub>9</sub> / TMIO <sub>1</sub> / /DREQ <sub>0</sub>	PB <sub>7</sub> /TP <sub>9</sub> / TMIO <sub>1</sub> / /DREQ <sub>0</sub>
4	6		PB <sub>7</sub> /TP <sub>10</sub> / /TMO <sub>2</sub> /CS <sub>5</sub>	PB <sub>7</sub> /TP <sub>10</sub> / /TMO <sub>2</sub> /CS <sub>5</sub>	PB <sub>7</sub> /TP <sub>10</sub> / /TMO <sub>2</sub> /CS <sub>5</sub>	PB <sub>7</sub> /TP <sub>10</sub> / /TMO <sub>2</sub> /CS <sub>5</sub>	PB <sub>7</sub> /TP <sub>10</sub> / /TMO <sub>2</sub> /CS <sub>5</sub>	PB <sub>7</sub> /TP <sub>10</sub> / /TMO <sub>3</sub>	PB <sub>7</sub> /TP <sub>10</sub> / /TMO <sub>3</sub>
5	7		PB <sub>7</sub> /TP <sub>11</sub> / TMIO <sub>3</sub> / /DREQ <sub>1</sub> /CS <sub>4</sub>	PB <sub>7</sub> /TP <sub>11</sub> / TMIO <sub>3</sub> / /DREQ <sub>1</sub> /CS <sub>4</sub>	PB <sub>7</sub> /TP <sub>11</sub> / TMIO <sub>3</sub> / /DREQ <sub>1</sub> /CS <sub>4</sub>	PB <sub>7</sub> /TP <sub>11</sub> / TMIO <sub>3</sub> / /DREQ <sub>1</sub> /CS <sub>4</sub>	PB <sub>7</sub> /TP <sub>11</sub> / TMIO <sub>3</sub> / /DREQ <sub>1</sub> /CS <sub>2</sub>	PB <sub>7</sub> /TP <sub>11</sub> / TMIO <sub>3</sub> / /DREQ <sub>1</sub>	PB <sub>7</sub> /TP <sub>11</sub> / TMIO <sub>3</sub> / /DREQ <sub>1</sub>
6	8		PB <sub>7</sub> /TP <sub>12</sub> / /UCAS	PB <sub>7</sub> /TP <sub>12</sub> / /UCAS	PB <sub>7</sub> /TP <sub>12</sub> / /UCAS	PB <sub>7</sub> /TP <sub>12</sub> / /UCAS	PB <sub>7</sub> /TP <sub>12</sub> / /UCAS	PB <sub>7</sub> /TP <sub>12</sub>	PB <sub>7</sub> /TP <sub>12</sub>
7	9		PB <sub>7</sub> /TP <sub>13</sub> / /LCAS/SCK <sub>2</sub>	PB <sub>7</sub> /TP <sub>13</sub> / /LCAS/SCK <sub>2</sub>	PB <sub>7</sub> /TP <sub>13</sub> / /LCAS/SCK <sub>2</sub>	PB <sub>7</sub> /TP <sub>13</sub> / /LCAS/SCK <sub>2</sub>	PB <sub>7</sub> /TP <sub>13</sub> / /LCAS/SCK <sub>2</sub>	PB <sub>7</sub> /TP <sub>13</sub> / /SCK <sub>2</sub>	PB <sub>7</sub> /TP <sub>13</sub> / /SCK <sub>2</sub>
8	10		PB <sub>7</sub> /TP <sub>14</sub> / /TxD <sub>2</sub>	PB <sub>7</sub> /TP <sub>14</sub> / /TxD <sub>2</sub>	PB <sub>7</sub> /TP <sub>14</sub> / /TxD <sub>2</sub>	PB <sub>7</sub> /TP <sub>14</sub> / /TxD <sub>2</sub>	PB <sub>7</sub> /TP <sub>14</sub> / /TxD <sub>2</sub>	PB <sub>7</sub> /TP <sub>14</sub> / /TxD <sub>2</sub>	PB <sub>7</sub> /TP <sub>14</sub> / /TxD <sub>2</sub>
9	11		PB <sub>7</sub> /TP <sub>15</sub> / /RxD <sub>2</sub>	PB <sub>7</sub> /TP <sub>15</sub> / /RxD <sub>2</sub>	PB <sub>7</sub> /TP <sub>15</sub> / /RxD <sub>2</sub>	PB <sub>7</sub> /TP <sub>15</sub> / /RxD <sub>2</sub>	PB <sub>7</sub> /TP <sub>15</sub> / /RxD <sub>2</sub>	PB <sub>7</sub> /TP <sub>15</sub> / /RxD <sub>2</sub>	PB <sub>7</sub> /TP <sub>15</sub> / /RxD <sub>2</sub>
10	12		RES <sub>0</sub> /FWE <sup>*3</sup>	RES <sub>0</sub> /FWE <sup>*3</sup>	RES <sub>0</sub> /FWE <sup>*3</sup>	RES <sub>0</sub> /FWE <sup>*3</sup>	RES <sub>0</sub> /FWE <sup>*3</sup>	RES <sub>0</sub> /FWE <sup>*3</sup>	RES <sub>0</sub> /FWE <sup>*3</sup>
11	13		V <sub>SS</sub>	V <sub>SS</sub>	V <sub>SS</sub>	V <sub>SS</sub>	V <sub>SS</sub>	V <sub>SS</sub>	V <sub>SS</sub>
12	14		P9 <sub>7</sub> /TxD <sub>0</sub>	P9 <sub>7</sub> /TxD <sub>0</sub>	P9 <sub>7</sub> /TxD <sub>0</sub>	P9 <sub>7</sub> /TxD <sub>0</sub>	P9 <sub>7</sub> /TxD <sub>0</sub>	P9 <sub>7</sub> /TxD <sub>0</sub>	P9 <sub>7</sub> /TxD <sub>0</sub>
13	15		P9 <sub>7</sub> /TxD <sub>1</sub>	P9 <sub>7</sub> /TxD <sub>1</sub>	P9 <sub>7</sub> /TxD <sub>1</sub>	P9 <sub>7</sub> /TxD <sub>1</sub>	P9 <sub>7</sub> /TxD <sub>1</sub>	P9 <sub>7</sub> /TxD <sub>1</sub>	P9 <sub>7</sub> /TxD <sub>1</sub>
14	16		P9 <sub>7</sub> /RxD <sub>0</sub>	P9 <sub>7</sub> /RxD <sub>0</sub>	P9 <sub>7</sub> /RxD <sub>0</sub>	P9 <sub>7</sub> /RxD <sub>0</sub>	P9 <sub>7</sub> /RxD <sub>0</sub>	P9 <sub>7</sub> /RxD <sub>0</sub>	P9 <sub>7</sub> /RxD <sub>0</sub>
15	17		P9 <sub>7</sub> /RxD <sub>1</sub>	P9 <sub>7</sub> /RxD <sub>1</sub>	P9 <sub>7</sub> /RxD <sub>1</sub>	P9 <sub>7</sub> /RxD <sub>1</sub>	P9 <sub>7</sub> /RxD <sub>1</sub>	P9 <sub>7</sub> /RxD <sub>1</sub>	P9 <sub>7</sub> /RxD <sub>1</sub>
16	18		P9 <sub>7</sub> /IRQ <sub>4</sub> /SCK <sub>0</sub>	P9 <sub>7</sub> /IRQ <sub>4</sub> /SCK <sub>0</sub>	P9 <sub>7</sub> /IRQ <sub>4</sub> /SCK <sub>0</sub>	P9 <sub>7</sub> /IRQ <sub>4</sub> /SCK <sub>0</sub>	P9 <sub>7</sub> /IRQ <sub>4</sub> /SCK <sub>0</sub>	P9 <sub>7</sub> /IRQ <sub>4</sub> /SCK <sub>0</sub>	P9 <sub>7</sub> /IRQ <sub>4</sub> /SCK <sub>0</sub>
17	19		P9 <sub>7</sub> /IRQ <sub>5</sub> /SCK <sub>1</sub>	P9 <sub>7</sub> /IRQ <sub>5</sub> /SCK <sub>1</sub>	P9 <sub>7</sub> /IRQ <sub>5</sub> /SCK <sub>1</sub>	P9 <sub>7</sub> /IRQ <sub>5</sub> /SCK <sub>1</sub>	P9 <sub>7</sub> /IRQ <sub>5</sub> /SCK <sub>1</sub>	P9 <sub>7</sub> /IRQ <sub>5</sub> /SCK <sub>1</sub>	P9 <sub>7</sub> /IRQ <sub>5</sub> /SCK <sub>1</sub>
18	20		P4 <sub>0</sub> /D <sub>0</sub> <sup>*1</sup>	P4 <sub>0</sub> /D <sub>0</sub> <sup>*2</sup>	P4 <sub>0</sub> /D <sub>0</sub> <sup>*1</sup>	P4 <sub>0</sub> /D <sub>0</sub> <sup>*2</sup>	P4 <sub>0</sub> /D <sub>0</sub> <sup>*1</sup>	P4 <sub>0</sub>	P4 <sub>0</sub>
19	21		P4 <sub>0</sub> /D <sub>1</sub> <sup>*1</sup>	P4 <sub>0</sub> /D <sub>1</sub> <sup>*2</sup>	P4 <sub>0</sub> /D <sub>1</sub> <sup>*1</sup>	P4 <sub>0</sub> /D <sub>1</sub> <sup>*2</sup>	P4 <sub>0</sub> /D <sub>1</sub> <sup>*1</sup>	P4 <sub>1</sub>	P4 <sub>1</sub>
20	22		P4 <sub>0</sub> /D <sub>2</sub> <sup>*1</sup>	P4 <sub>0</sub> /D <sub>2</sub> <sup>*2</sup>	P4 <sub>0</sub> /D <sub>2</sub> <sup>*1</sup>	P4 <sub>0</sub> /D <sub>2</sub> <sup>*2</sup>	P4 <sub>0</sub> /D <sub>2</sub> <sup>*1</sup>	P4 <sub>2</sub>	P4 <sub>2</sub>
21	23		P4 <sub>0</sub> /D <sub>3</sub> <sup>*1</sup>	P4 <sub>0</sub> /D <sub>3</sub> <sup>*2</sup>	P4 <sub>0</sub> /D <sub>3</sub> <sup>*1</sup>	P4 <sub>0</sub> /D <sub>3</sub> <sup>*2</sup>	P4 <sub>0</sub> /D <sub>3</sub> <sup>*1</sup>	P4 <sub>3</sub>	P4 <sub>3</sub>
22	24		V <sub>SS</sub>	V <sub>SS</sub>	V <sub>SS</sub>	V <sub>SS</sub>	V <sub>SS</sub>	V <sub>SS</sub>	V <sub>SS</sub>

- Notes: 1. In modes 1, 3, 5 the P4<sub>0</sub> to P4<sub>7</sub> functions of pins P4<sub>0</sub>/D<sub>0</sub> to P4<sub>7</sub>/D<sub>7</sub> are selected after a reset, but they can be changed by software.
2. In modes 2 and 4 the D<sub>0</sub> to D<sub>7</sub> functions of pins P4<sub>0</sub>/D<sub>0</sub> to P4<sub>7</sub>/D<sub>7</sub> are selected after a reset, but they can be changed by software.
3. Functions as  $\overline{\text{RES}}_0$  in the mask ROM versions, and as FWE in the flash memory and flash memory R versions.

**Table 1.3 Pin Assignments in Each Mode (FP-100B or TFP-100B, FP-100A) (cont)**

Pin No.		Pin name						
FP-100B	FP-100A	Mode 1	Mode 2	Mode 3	Mode 4	Mode 5	Mode 6	Mode 7
23	25	P <sub>4</sub> /D <sub>4</sub> <sup>*1</sup>	P <sub>4</sub> /D <sub>4</sub> <sup>*2</sup>	P <sub>4</sub> /D <sub>4</sub> <sup>*1</sup>	P <sub>4</sub> /D <sub>4</sub> <sup>*2</sup>	P <sub>4</sub> /D <sub>4</sub> <sup>*1</sup>	P <sub>4</sub>	P <sub>4</sub>
24	26	P <sub>4</sub> /D <sub>5</sub> <sup>*1</sup>	P <sub>4</sub> /D <sub>5</sub> <sup>*2</sup>	P <sub>4</sub> /D <sub>5</sub> <sup>*1</sup>	P <sub>4</sub> /D <sub>5</sub> <sup>*2</sup>	P <sub>4</sub> /D <sub>5</sub> <sup>*1</sup>	P <sub>4</sub>	P <sub>4</sub>
25	27	P <sub>4</sub> /D <sub>6</sub> <sup>*1</sup>	P <sub>4</sub> /D <sub>6</sub> <sup>*2</sup>	P <sub>4</sub> /D <sub>6</sub> <sup>*1</sup>	P <sub>4</sub> /D <sub>6</sub> <sup>*2</sup>	P <sub>4</sub> /D <sub>6</sub> <sup>*1</sup>	P <sub>4</sub>	P <sub>4</sub>
26	28	P <sub>4</sub> /D <sub>7</sub> <sup>*1</sup>	P <sub>4</sub> /D <sub>7</sub> <sup>*2</sup>	P <sub>4</sub> /D <sub>7</sub> <sup>*1</sup>	P <sub>4</sub> /D <sub>7</sub> <sup>*2</sup>	P <sub>4</sub> /D <sub>7</sub> <sup>*1</sup>	P <sub>4</sub>	P <sub>4</sub>
27	29	D <sub>8</sub>	D <sub>8</sub>	D <sub>8</sub>	D <sub>8</sub>	D <sub>8</sub>	P <sub>3</sub> <sub>0</sub>	P <sub>3</sub> <sub>0</sub>
28	30	D <sub>9</sub>	D <sub>9</sub>	D <sub>9</sub>	D <sub>9</sub>	D <sub>9</sub>	P <sub>3</sub> <sub>1</sub>	P <sub>3</sub> <sub>1</sub>
29	31	D <sub>10</sub>	D <sub>10</sub>	D <sub>10</sub>	D <sub>10</sub>	D <sub>10</sub>	P <sub>3</sub> <sub>2</sub>	P <sub>3</sub> <sub>2</sub>
30	32	D <sub>11</sub>	D <sub>11</sub>	D <sub>11</sub>	D <sub>11</sub>	D <sub>11</sub>	P <sub>3</sub> <sub>3</sub>	P <sub>3</sub> <sub>3</sub>
31	33	D <sub>12</sub>	D <sub>12</sub>	D <sub>12</sub>	D <sub>12</sub>	D <sub>12</sub>	P <sub>3</sub> <sub>4</sub>	P <sub>3</sub> <sub>4</sub>
32	34	D <sub>13</sub>	D <sub>13</sub>	D <sub>13</sub>	D <sub>13</sub>	D <sub>13</sub>	P <sub>3</sub> <sub>5</sub>	P <sub>3</sub> <sub>5</sub>
33	35	D <sub>14</sub>	D <sub>14</sub>	D <sub>14</sub>	D <sub>14</sub>	D <sub>14</sub>	P <sub>3</sub> <sub>6</sub>	P <sub>3</sub> <sub>6</sub>
34	36	D <sub>15</sub>	D <sub>15</sub>	D <sub>15</sub>	D <sub>15</sub>	D <sub>15</sub>	P <sub>3</sub> <sub>7</sub>	P <sub>3</sub> <sub>7</sub>
35	37	V <sub>CC</sub>	V <sub>CC</sub>	V <sub>CC</sub>	V <sub>CC</sub>	V <sub>CC</sub>	V <sub>CC</sub>	V <sub>CC</sub>
36	38	A <sub>0</sub>	A <sub>0</sub>	A <sub>0</sub>	A <sub>0</sub>	P1 <sub>1</sub> /A <sub>0</sub>	P1 <sub>0</sub>	P1 <sub>0</sub>
37	39	A <sub>1</sub>	A <sub>1</sub>	A <sub>1</sub>	A <sub>1</sub>	P1 <sub>1</sub> /A <sub>1</sub>	P1 <sub>1</sub>	P1 <sub>1</sub>
38	40	A <sub>2</sub>	A <sub>2</sub>	A <sub>2</sub>	A <sub>2</sub>	P1 <sub>1</sub> /A <sub>2</sub>	P1 <sub>2</sub>	P1 <sub>2</sub>
39	41	A <sub>3</sub>	A <sub>3</sub>	A <sub>3</sub>	A <sub>3</sub>	P1 <sub>1</sub> /A <sub>3</sub>	P1 <sub>3</sub>	P1 <sub>3</sub>
40	42	A <sub>4</sub>	A <sub>4</sub>	A <sub>4</sub>	A <sub>4</sub>	P1 <sub>1</sub> /A <sub>4</sub>	P1 <sub>4</sub>	P1 <sub>4</sub>
41	43	A <sub>5</sub>	A <sub>5</sub>	A <sub>5</sub>	A <sub>5</sub>	P1 <sub>1</sub> /A <sub>5</sub>	P1 <sub>5</sub>	P1 <sub>5</sub>
42	44	A <sub>6</sub>	A <sub>6</sub>	A <sub>6</sub>	A <sub>6</sub>	P1 <sub>1</sub> /A <sub>6</sub>	P1 <sub>6</sub>	P1 <sub>6</sub>
43	45	A <sub>7</sub>	A <sub>7</sub>	A <sub>7</sub>	A <sub>7</sub>	P1 <sub>1</sub> /A <sub>7</sub>	P1 <sub>7</sub>	P1 <sub>7</sub>
44	46	V <sub>SS</sub>	V <sub>SS</sub>	V <sub>SS</sub>	V <sub>SS</sub>	V <sub>SS</sub>	V <sub>SS</sub>	V <sub>SS</sub>
45	47	A <sub>8</sub>	A <sub>8</sub>	A <sub>8</sub>	A <sub>8</sub>	P2 <sub>2</sub> /A <sub>8</sub>	P2 <sub>0</sub>	P2 <sub>0</sub>
46	48	A <sub>9</sub>	A <sub>9</sub>	A <sub>9</sub>	A <sub>9</sub>	P2 <sub>2</sub> /A <sub>9</sub>	P2 <sub>1</sub>	P2 <sub>1</sub>
47	49	A <sub>10</sub>	A <sub>10</sub>	A <sub>10</sub>	A <sub>10</sub>	P2 <sub>2</sub> /A <sub>10</sub>	P2 <sub>2</sub>	P2 <sub>2</sub>
48	50	A <sub>11</sub>	A <sub>11</sub>	A <sub>11</sub>	A <sub>11</sub>	P2 <sub>2</sub> /A <sub>11</sub>	P2 <sub>3</sub>	P2 <sub>3</sub>
49	51	A <sub>12</sub>	A <sub>12</sub>	A <sub>12</sub>	A <sub>12</sub>	P2 <sub>2</sub> /A <sub>12</sub>	P2 <sub>4</sub>	P2 <sub>4</sub>
50	52	A <sub>13</sub>	A <sub>13</sub>	A <sub>13</sub>	A <sub>13</sub>	P2 <sub>2</sub> /A <sub>13</sub>	P2 <sub>5</sub>	P2 <sub>5</sub>
51	53	A <sub>14</sub>	A <sub>14</sub>	A <sub>14</sub>	A <sub>14</sub>	P2 <sub>2</sub> /A <sub>14</sub>	P2 <sub>6</sub>	P2 <sub>6</sub>
52	54	A <sub>15</sub>	A <sub>15</sub>	A <sub>15</sub>	A <sub>15</sub>	P2 <sub>2</sub> /A <sub>15</sub>	P2 <sub>7</sub>	P2 <sub>7</sub>
53	55	A <sub>16</sub>	A <sub>16</sub>	A <sub>16</sub>	A <sub>16</sub>	P5 <sub>2</sub> /A <sub>16</sub>	P5 <sub>0</sub>	P5 <sub>0</sub>
54	56	A <sub>17</sub>	A <sub>17</sub>	A <sub>17</sub>	A <sub>17</sub>	P5 <sub>2</sub> /A <sub>17</sub>	P5 <sub>1</sub>	P5 <sub>1</sub>
55	57	A <sub>18</sub>	A <sub>18</sub>	A <sub>18</sub>	A <sub>18</sub>	P5 <sub>2</sub> /A <sub>18</sub>	P5 <sub>2</sub>	P5 <sub>2</sub>
56	58	A <sub>19</sub>	A <sub>19</sub>	A <sub>19</sub>	A <sub>19</sub>	P5 <sub>2</sub> /A <sub>19</sub>	P5 <sub>3</sub>	P5 <sub>3</sub>

- Notes: 1. In modes 1, 3, 5 the P<sub>4</sub><sub>0</sub> to P<sub>4</sub><sub>7</sub> functions of pins P<sub>4</sub><sub>0</sub>/D<sub>0</sub> to P<sub>4</sub><sub>7</sub>/D<sub>7</sub> are selected after a reset, but they can be changed by software.
2. In modes 2 and 4 the D<sub>0</sub> to D<sub>7</sub> functions of pins P<sub>4</sub><sub>0</sub>/D<sub>0</sub> to P<sub>4</sub><sub>7</sub>/D<sub>7</sub> are selected after a reset, but they can be changed by software.

**Table 1.3 Pin Assignments in Each Mode (FP-100B or TFP-100B, FP-100A) (cont)**

Pin No.		Pin name							
FP-100B	TFP-100B	FP-100A	Mode 1	Mode 2	Mode 3	Mode 4	Mode 5	Mode 6	Mode 7
57	59		V <sub>SS</sub>	V <sub>SS</sub>	V <sub>SS</sub>	V <sub>SS</sub>	V <sub>SS</sub>	V <sub>SS</sub>	V <sub>SS</sub>
58	60		P6 <sub>0</sub> /WAIT	P6 <sub>0</sub> /WAIT	P6 <sub>0</sub> /WAIT	P6 <sub>0</sub> /WAIT	P6 <sub>0</sub> /WAIT	P6 <sub>0</sub>	P6 <sub>0</sub>
59	61		P6 <sub>0</sub> /BREQ	P6 <sub>0</sub> /BREQ	P6 <sub>0</sub> /BREQ	P6 <sub>0</sub> /BREQ	P6 <sub>0</sub> /BREQ	P6 <sub>1</sub>	P6 <sub>1</sub>
60	62		P6 <sub>0</sub> /BACK	P6 <sub>0</sub> /BACK	P6 <sub>0</sub> /BACK	P6 <sub>0</sub> /BACK	P6 <sub>0</sub> /BACK	P6 <sub>2</sub>	P6 <sub>2</sub>
61	63		φ	φ	φ	φ	P6 <sub>0</sub> /φ	P6 <sub>0</sub> /φ	P6 <sub>0</sub> /φ
62	64		STBY	STBY	STBY	STBY	STBY	STBY	STBY
63	65		RES	RES	RES	RES	RES	RES	RES
64	66		NMI	NMI	NMI	NMI	NMI	NMI	NMI
65	67		V <sub>SS</sub>	V <sub>SS</sub>	V <sub>SS</sub>	V <sub>SS</sub>	V <sub>SS</sub>	V <sub>SS</sub>	V <sub>SS</sub>
66	68		EXTAL	EXTAL	EXTAL	EXTAL	EXTAL	EXTAL	EXTAL
67	69		XTAL	XTAL	XTAL	XTAL	XTAL	XTAL	XTAL
68	70		V <sub>CC</sub>	V <sub>CC</sub>	V <sub>CC</sub>	V <sub>CC</sub>	V <sub>CC</sub>	V <sub>CC</sub>	V <sub>CC</sub>
69	71		$\overline{AS}$	$\overline{AS}$	$\overline{AS}$	$\overline{AS}$	$\overline{AS}$	P6 <sub>3</sub>	P6 <sub>3</sub>
70	72		$\overline{RD}$	$\overline{RD}$	$\overline{RD}$	$\overline{RD}$	$\overline{RD}$	P6 <sub>4</sub>	P6 <sub>4</sub>
71	73		$\overline{HWR}$	$\overline{HWR}$	$\overline{HWR}$	$\overline{HWR}$	$\overline{HWR}$	P6 <sub>5</sub>	P6 <sub>5</sub>
72	74		$\overline{LWR}$	$\overline{LWR}$	$\overline{LWR}$	$\overline{LWR}$	$\overline{LWR}$	P6 <sub>6</sub>	P6 <sub>6</sub>
73	75		MD <sub>0</sub>	MD <sub>0</sub>	MD <sub>0</sub>	MD <sub>0</sub>	MD <sub>0</sub>	MD <sub>0</sub>	MD <sub>0</sub>
74	76		MD <sub>1</sub>	MD <sub>1</sub>	MD <sub>1</sub>	MD <sub>1</sub>	MD <sub>1</sub>	MD <sub>1</sub>	MD <sub>1</sub>
75	77		MD <sub>2</sub>	MD <sub>2</sub>	MD <sub>2</sub>	MD <sub>2</sub>	MD <sub>2</sub>	MD <sub>2</sub>	MD <sub>2</sub>
76	78		AV <sub>CC</sub>	AV <sub>CC</sub>	AV <sub>CC</sub>	AV <sub>CC</sub>	AV <sub>CC</sub>	AV <sub>CC</sub>	AV <sub>CC</sub>
77	79		V <sub>REF</sub>	V <sub>REF</sub>	V <sub>REF</sub>	V <sub>REF</sub>	V <sub>REF</sub>	V <sub>REF</sub>	V <sub>REF</sub>
78	80		P7 <sub>0</sub> /AN <sub>0</sub>	P7 <sub>0</sub> /AN <sub>0</sub>	P7 <sub>0</sub> /AN <sub>0</sub>	P7 <sub>0</sub> /AN <sub>0</sub>	P7 <sub>0</sub> /AN <sub>0</sub>	P7 <sub>0</sub> /AN <sub>0</sub>	P7 <sub>0</sub> /AN <sub>0</sub>
79	81		P7 <sub>0</sub> /AN <sub>1</sub>	P7 <sub>0</sub> /AN <sub>1</sub>	P7 <sub>0</sub> /AN <sub>1</sub>	P7 <sub>0</sub> /AN <sub>1</sub>	P7 <sub>0</sub> /AN <sub>1</sub>	P7 <sub>0</sub> /AN <sub>1</sub>	P7 <sub>0</sub> /AN <sub>1</sub>
80	82		P7 <sub>0</sub> /AN <sub>2</sub>	P7 <sub>0</sub> /AN <sub>2</sub>	P7 <sub>0</sub> /AN <sub>2</sub>	P7 <sub>0</sub> /AN <sub>2</sub>	P7 <sub>0</sub> /AN <sub>2</sub>	P7 <sub>0</sub> /AN <sub>2</sub>	P7 <sub>0</sub> /AN <sub>2</sub>
81	83		P7 <sub>0</sub> /AN <sub>3</sub>	P7 <sub>0</sub> /AN <sub>3</sub>	P7 <sub>0</sub> /AN <sub>3</sub>	P7 <sub>0</sub> /AN <sub>3</sub>	P7 <sub>0</sub> /AN <sub>3</sub>	P7 <sub>0</sub> /AN <sub>3</sub>	P7 <sub>0</sub> /AN <sub>3</sub>
82	84		P7 <sub>0</sub> /AN <sub>4</sub>	P7 <sub>0</sub> /AN <sub>4</sub>	P7 <sub>0</sub> /AN <sub>4</sub>	P7 <sub>0</sub> /AN <sub>4</sub>	P7 <sub>0</sub> /AN <sub>4</sub>	P7 <sub>0</sub> /AN <sub>4</sub>	P7 <sub>0</sub> /AN <sub>4</sub>
83	85		P7 <sub>0</sub> /AN <sub>5</sub>	P7 <sub>0</sub> /AN <sub>5</sub>	P7 <sub>0</sub> /AN <sub>5</sub>	P7 <sub>0</sub> /AN <sub>5</sub>	P7 <sub>0</sub> /AN <sub>5</sub>	P7 <sub>0</sub> /AN <sub>5</sub>	P7 <sub>0</sub> /AN <sub>5</sub>
84	86		P7 <sub>0</sub> /AN <sub>6</sub> /DA <sub>0</sub>	P7 <sub>0</sub> /AN <sub>6</sub> /DA <sub>0</sub>	P7 <sub>0</sub> /AN <sub>6</sub> /DA <sub>0</sub>	P7 <sub>0</sub> /AN <sub>6</sub> /DA <sub>0</sub>	P7 <sub>0</sub> /AN <sub>6</sub> /DA <sub>0</sub>	P7 <sub>0</sub> /AN <sub>6</sub> /DA <sub>0</sub>	P7 <sub>0</sub> /AN <sub>6</sub> /DA <sub>0</sub>
85	87		P7 <sub>0</sub> /AN <sub>7</sub> /DA <sub>1</sub>	P7 <sub>0</sub> /AN <sub>7</sub> /DA <sub>1</sub>	P7 <sub>0</sub> /AN <sub>7</sub> /DA <sub>1</sub>	P7 <sub>0</sub> /AN <sub>7</sub> /DA <sub>1</sub>	P7 <sub>0</sub> /AN <sub>7</sub> /DA <sub>1</sub>	P7 <sub>0</sub> /AN <sub>7</sub> /DA <sub>1</sub>	P7 <sub>0</sub> /AN <sub>7</sub> /DA <sub>1</sub>
86	88		AV <sub>SS</sub>	AV <sub>SS</sub>	AV <sub>SS</sub>	AV <sub>SS</sub>	AV <sub>SS</sub>	AV <sub>SS</sub>	AV <sub>SS</sub>
87	89		P8 <sub>0</sub> /IRQ <sub>0</sub> / RFSH	P8 <sub>0</sub> /IRQ <sub>0</sub> / RFSH	P8 <sub>0</sub> /IRQ <sub>0</sub> / RFSH	P8 <sub>0</sub> /IRQ <sub>0</sub> / RFSH	P8 <sub>0</sub> /IRQ <sub>0</sub> / RFSH	P8 <sub>0</sub> /IRQ <sub>0</sub>	P8 <sub>0</sub> /IRQ <sub>0</sub>

**Table 1.3 Pin Assignments in Each Mode (FP-100B or TFP-100B, FP-100A) (cont)**

Pin No.		Pin name							
FP-100B	TFP-100B	FP-100A	Mode 1	Mode 2	Mode 3	Mode 4	Mode 5	Mode 6	Mode 7
88	90		P8 <sub>1</sub> /IRQ <sub>1</sub> /CS <sub>3</sub>	P8 <sub>2</sub> /IRQ <sub>2</sub> /CS <sub>3</sub>	P8 <sub>3</sub> /IRQ <sub>3</sub> /CS <sub>3</sub>	P8 <sub>4</sub> /IRQ <sub>4</sub> /CS <sub>3</sub>	P8 <sub>5</sub> /IRQ <sub>5</sub> /CS <sub>3</sub>	P8 <sub>6</sub> /IRQ <sub>6</sub>	P8 <sub>7</sub> /IRQ <sub>7</sub>
89	91		P8 <sub>1</sub> /IRQ <sub>1</sub> /CS <sub>2</sub>	P8 <sub>2</sub> /IRQ <sub>2</sub> /CS <sub>2</sub>	P8 <sub>3</sub> /IRQ <sub>3</sub> /CS <sub>2</sub>	P8 <sub>4</sub> /IRQ <sub>4</sub> /CS <sub>2</sub>	P8 <sub>5</sub> /IRQ <sub>5</sub> /CS <sub>2</sub>	P8 <sub>6</sub> /IRQ <sub>6</sub>	P8 <sub>7</sub> /IRQ <sub>7</sub>
90	92		P8 <sub>1</sub> /IRQ <sub>1</sub> /CS <sub>1</sub> ADTRG	P8 <sub>2</sub> /IRQ <sub>2</sub> /CS <sub>1</sub> ADTRG	P8 <sub>3</sub> /IRQ <sub>3</sub> /CS <sub>1</sub> ADTRG	P8 <sub>4</sub> /IRQ <sub>4</sub> /CS <sub>1</sub> ADTRG	P8 <sub>5</sub> /IRQ <sub>5</sub> /CS <sub>1</sub> ADTRG	P8 <sub>6</sub> /IRQ <sub>6</sub> ADTRG	P8 <sub>7</sub> /IRQ <sub>7</sub> ADTRG
91	93		P8 <sub>1</sub> /CS <sub>0</sub>	P8 <sub>2</sub> /CS <sub>0</sub>	P8 <sub>3</sub> /CS <sub>0</sub>	P8 <sub>4</sub> /CS <sub>0</sub>	P8 <sub>5</sub> /CS <sub>0</sub>	P8 <sub>6</sub>	P8 <sub>7</sub>
92	94		V <sub>SS</sub>	V <sub>SS</sub>	V <sub>SS</sub>	V <sub>SS</sub>	V <sub>SS</sub>	V <sub>SS</sub>	V <sub>SS</sub>
93	95		PA <sub>1</sub> /TP <sub>1</sub> / TCLKA/ TEND <sub>0</sub>	PA <sub>2</sub> /TP <sub>2</sub> / TCLKA/ TEND <sub>0</sub>	PA <sub>3</sub> /TP <sub>3</sub> / TCLKA/ TEND <sub>0</sub>	PA <sub>4</sub> /TP <sub>4</sub> / TCLKA/ TEND <sub>0</sub>	PA <sub>5</sub> /TP <sub>5</sub> / TCLKA/ TEND <sub>0</sub>	PA <sub>6</sub> /TP <sub>6</sub> / TCLKA/ TEND <sub>0</sub>	PA <sub>7</sub> /TP <sub>7</sub> / TCLKA/ TEND <sub>0</sub>
94	96		PA <sub>1</sub> /TP <sub>1</sub> / TCLKB/ TEND <sub>1</sub>	PA <sub>2</sub> /TP <sub>2</sub> / TCLKB/ TEND <sub>1</sub>	PA <sub>3</sub> /TP <sub>3</sub> / TCLKB/ TEND <sub>1</sub>	PA <sub>4</sub> /TP <sub>4</sub> / TCLKB/ TEND <sub>1</sub>	PA <sub>5</sub> /TP <sub>5</sub> / TCLKB/ TEND <sub>1</sub>	PA <sub>6</sub> /TP <sub>6</sub> / TCLKB/ TEND <sub>1</sub>	PA <sub>7</sub> /TP <sub>7</sub> / TCLKB/ TEND <sub>1</sub>
95	97		PA <sub>2</sub> /TP <sub>2</sub> / TIOCA <sub>1</sub> / TCLKC	PA <sub>3</sub> /TP <sub>3</sub> / TIOCA <sub>1</sub> / TCLKC	PA <sub>4</sub> /TP <sub>4</sub> / TIOCA <sub>1</sub> / TCLKC	PA <sub>5</sub> /TP <sub>5</sub> / TIOCA <sub>1</sub> / TCLKC	PA <sub>6</sub> /TP <sub>6</sub> / TIOCA <sub>1</sub> / TCLKC	PA <sub>7</sub> /TP <sub>7</sub> / TIOCA <sub>1</sub> / TCLKC	PA <sub>8</sub> /TP <sub>8</sub> / TIOCA <sub>1</sub> / TCLKC
96	98		PA <sub>2</sub> /TP <sub>2</sub> / TIOCB <sub>1</sub> / TCLKD	PA <sub>3</sub> /TP <sub>3</sub> / TIOCB <sub>1</sub> / TCLKD	PA <sub>4</sub> /TP <sub>4</sub> / TIOCB <sub>1</sub> / TCLKD	PA <sub>5</sub> /TP <sub>5</sub> / TIOCB <sub>1</sub> / TCLKD	PA <sub>6</sub> /TP <sub>6</sub> / TIOCB <sub>1</sub> / TCLKD	PA <sub>7</sub> /TP <sub>7</sub> / TIOCB <sub>1</sub> / TCLKD	PA <sub>8</sub> /TP <sub>8</sub> / TIOCB <sub>1</sub> / TCLKD
97	99		PA <sub>4</sub> /TP <sub>4</sub> / TIOCA <sub>1</sub>	PA <sub>5</sub> /TP <sub>5</sub> / TIOCA <sub>1</sub>	PA <sub>6</sub> /TP <sub>6</sub> / TIOCA <sub>1</sub> /A <sub>23</sub>	PA <sub>7</sub> /TP <sub>7</sub> / TIOCA <sub>1</sub> /A <sub>23</sub>	PA <sub>8</sub> /TP <sub>8</sub> / TIOCA <sub>1</sub> /A <sub>23</sub>	PA <sub>9</sub> /TP <sub>9</sub> / TIOCA <sub>1</sub>	PA <sub>10</sub> /TP <sub>10</sub> / TIOCA <sub>1</sub>
98	100		PA <sub>4</sub> /TP <sub>4</sub> / TIOCB <sub>1</sub>	PA <sub>5</sub> /TP <sub>5</sub> / TIOCB <sub>1</sub>	PA <sub>6</sub> /TP <sub>6</sub> / TIOCB <sub>1</sub> /A <sub>22</sub>	PA <sub>7</sub> /TP <sub>7</sub> / TIOCB <sub>1</sub> /A <sub>22</sub>	PA <sub>8</sub> /TP <sub>8</sub> / TIOCB <sub>1</sub> /A <sub>22</sub>	PA <sub>9</sub> /TP <sub>9</sub> / TIOCB <sub>1</sub>	PA <sub>10</sub> /TP <sub>10</sub> / TIOCB <sub>1</sub>
99	1		PA <sub>6</sub> /TP <sub>6</sub> / TIOCA <sub>2</sub>	PA <sub>7</sub> /TP <sub>7</sub> / TIOCA <sub>2</sub>	PA <sub>8</sub> /TP <sub>8</sub> / TIOCA <sub>2</sub> /A <sub>21</sub>	PA <sub>9</sub> /TP <sub>9</sub> / TIOCA <sub>2</sub> /A <sub>21</sub>	PA <sub>10</sub> /TP <sub>10</sub> / TIOCA <sub>2</sub> /A <sub>21</sub>	PA <sub>11</sub> /TP <sub>11</sub> / TIOCA <sub>2</sub>	PA <sub>12</sub> /TP <sub>12</sub> / TIOCA <sub>2</sub>
100	2		PA <sub>7</sub> /TP <sub>7</sub> /TIOCB <sub>2</sub>	PA <sub>8</sub> /TP <sub>8</sub> /TIOCB <sub>2</sub>	A <sub>20</sub>	A <sub>20</sub>	PA <sub>9</sub> /TP <sub>9</sub> /TIOCB <sub>2</sub> /A <sub>20</sub>	PA <sub>10</sub> /TP <sub>10</sub> /TIOCB <sub>2</sub>	PA <sub>11</sub> /TP <sub>11</sub> /TIOCB <sub>2</sub>

## 1.4 Notes on Flash Memory R Version Model

There are two models with on-chip flash memory in the H8/3067 Series: the flash memory version (HD64F3067) and the flash memory R version (HD64F3067R). Points to be noted when using the flash memory R version are given below.

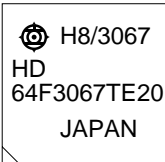
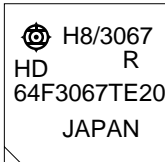
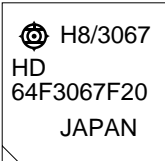
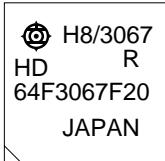

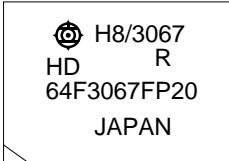
### 1.4.1 Pin Arrangement

The flash memory R version has the same pin arrangement as the flash memory version and mask ROM versions.

### 1.4.2 Product Type Names and Markings

Table 1.4 shows the product type names and differences in sample markings for the flash memory version and flash memory R version.

**Table 1.4 Differences in Flash Memory Version and Flash Memory R Version Markings**

		Flash Memory Version	Flash Memory R Version
TFP-100	Product type name	HD64F3067TE	HD64F3067RTE
	Sample markings		 <p>"R" is printed above the type name</p>
FP-100B	Product type name	HD64F3067F	HD64F3067RF
	Sample markings		 <p>"R" is printed above the type name</p>
FP-100A	Product type name	HD64F3067FP	HD64F3067RFP
	Sample markings		 <p>"R" is printed above the type name</p>

### 1.4.3 Differences in Flash Memory R Version

Table 1.5 shows the differences between the flash memory version, flash memory R version, and mask ROM versions.

**Table 1.5 Differences between Flash Memory Version, Flash Memory R Version, and Mask ROM Versions**

Item	Flash Memory Version HD64F3067	Flash Memory R Version HD64F3067R	Mask ROM Versions																		
			HD6433067	HD6433066	HD6433065																
ROM	128 kB flash memory		128 kB mask ROM	96 kB mask ROM	64 kB mask ROM																
Address output functions	Compatible with previous H8/300H Series	Choice of address update mode 1 (compatible with previous H8/300H Series) or address update mode 2 See the section on the bus controller for details.																			
ADRCR register (H'FEE01E)	—	<table border="1" style="margin-left: auto; margin-right: auto;"> <tr> <td style="text-align: center;">7</td> <td style="text-align: center;">6</td> <td style="text-align: center;">5</td> <td style="text-align: center;">4</td> <td style="text-align: center;">3</td> <td style="text-align: center;">2</td> <td style="text-align: center;">1</td> <td style="text-align: center;">0</td> </tr> <tr> <td style="text-align: center;">—</td> <td style="text-align: center;">—</td> <td style="text-align: center;">—</td> <td style="text-align: center;">—</td> <td style="text-align: center;">—</td> <td style="text-align: center;">—</td> <td style="text-align: center;">—</td> <td style="text-align: center;">ADRCTL</td> </tr> </table>				7	6	5	4	3	2	1	0	—	—	—	—	—	—	—	ADRCTL
7	6	5	4	3	2	1	0														
—	—	—	—	—	—	—	ADRCTL														
	Corresponding address consists of reserved bits	See the section on the bus controller for the bit function.																			





# Section 2 CPU

## 2.1 Overview

The H8/300H CPU is a high-speed central processing unit with an internal 32-bit architecture that is upward-compatible with the H8/300 CPU. The H8/300H CPU has sixteen 16-bit general registers, can address a 16-Mbyte linear address space, and is ideal for realtime control.

### 2.1.1 Features

The H8/300H CPU has the following features.

- Upward compatibility with H8/300 CPU  
Can execute H8/300 Series object programs
- General-register architecture  
Sixteen 16-bit general registers (also usable as sixteen 8-bit registers or eight 32-bit registers)
- Sixty-two basic instructions
  - 8/16/32-bit arithmetic and logic instructions
  - Multiply and divide instructions
  - Powerful bit-manipulation instructions
- Eight addressing modes
  - Register direct [Rn]
  - Register indirect [@ERn]
  - Register indirect with displacement [@(d:16, ERn) or @(d:24, ERn)]
  - Register indirect with post-increment or pre-decrement [@ERn+ or @-ERn]
  - Absolute address [@aa:8, @aa:16, or @aa:24]
  - Immediate [#xx:8, #xx:16, or #xx:32]
  - Program-counter relative [@(d:8, PC) or @(d:16, PC)]
  - Memory indirect [@@aa:8]
- 16-Mbyte linear address space

- High-speed operation
  - All frequently-used instructions execute in two to four states
  - Maximum clock frequency: 20 MHz
  - 8/16/32-bit register-register add/subtract: 100 ns
  - $8 \times 8$ -bit register-register multiply: 700 ns
  - $16 \div 8$ -bit register-register divide: 700 ns
  - $16 \times 16$ -bit register-register multiply: 1.1  $\mu$ s
  - $32 \div 16$ -bit register-register divide: 1.1  $\mu$ s
- Two CPU operating modes
  - Normal mode
  - Advanced mode
- Low-power mode
  - Transition to power-down state by SLEEP instruction

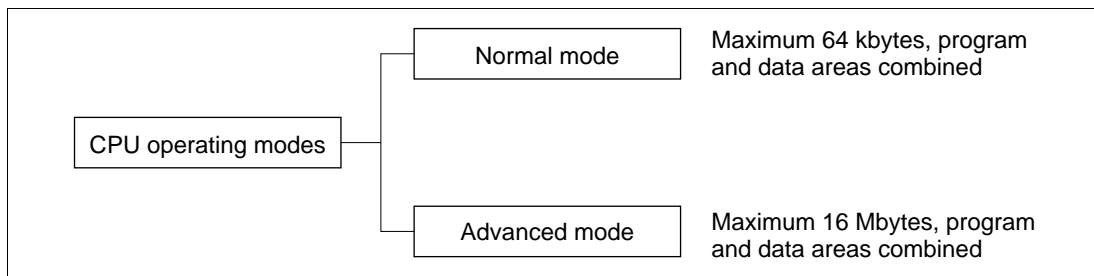
### 2.1.2 Differences from H8/300 CPU

In comparison to the H8/300 CPU, the H8/300H has the following enhancements.

- More general registers
  - Eight 16-bit registers have been added.
- Expanded address space
  - Advanced mode supports a maximum 16-Mbyte address space.
  - Normal mode supports the same 64-kbyte address space as the H8/300 CPU.
- Enhanced addressing
  - The addressing modes have been enhanced to make effective use of the 16-Mbyte address space.
- Enhanced instructions
  - Data transfer, arithmetic, and logic instructions can operate on 32-bit data.
  - Signed multiply/divide instructions and other instructions have been added.

## 2.2 CPU Operating Modes

The H8/300H CPU has two operating modes: normal and advanced. Normal mode supports a maximum 64-kbyte address space. Advanced mode supports up to 16 Mbytes.

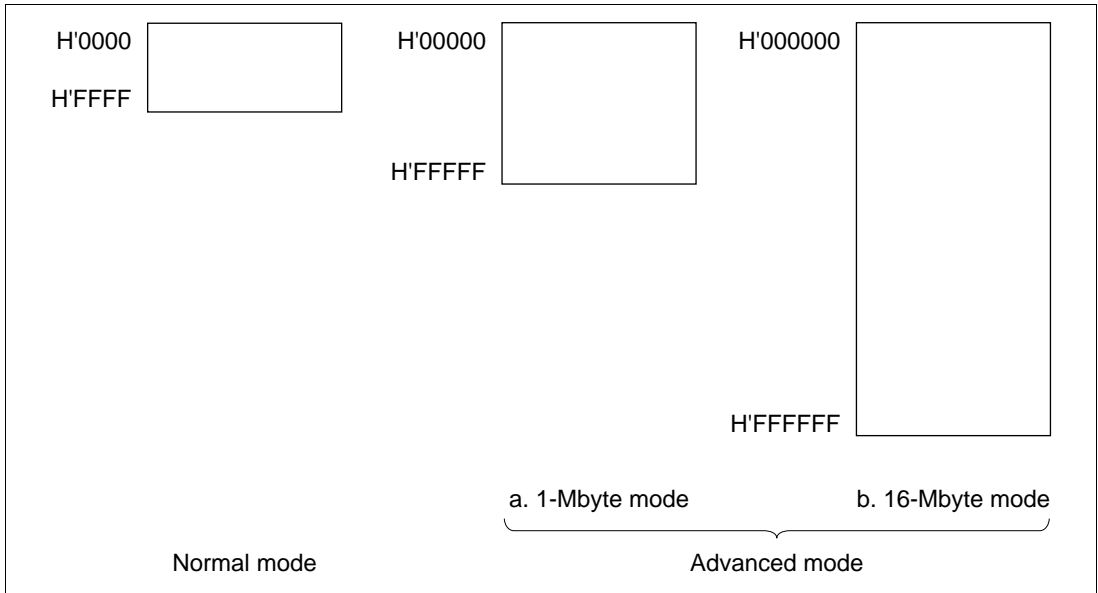


**Figure 2.1 CPU Operating Modes**

## 2.3 Address Space

Figure 2.2 shows a simple memory map for the H8/3067 Series. The H8/300H CPU can address a linear address space with a maximum size of 64 kbytes in normal mode, and 16 Mbytes in advanced mode. For further details see section 3.6, Memory Map in Each Operating Mode.

The 1-Mbyte operating modes use 20-bit addressing. The upper 4 bits of effective addresses are ignored.

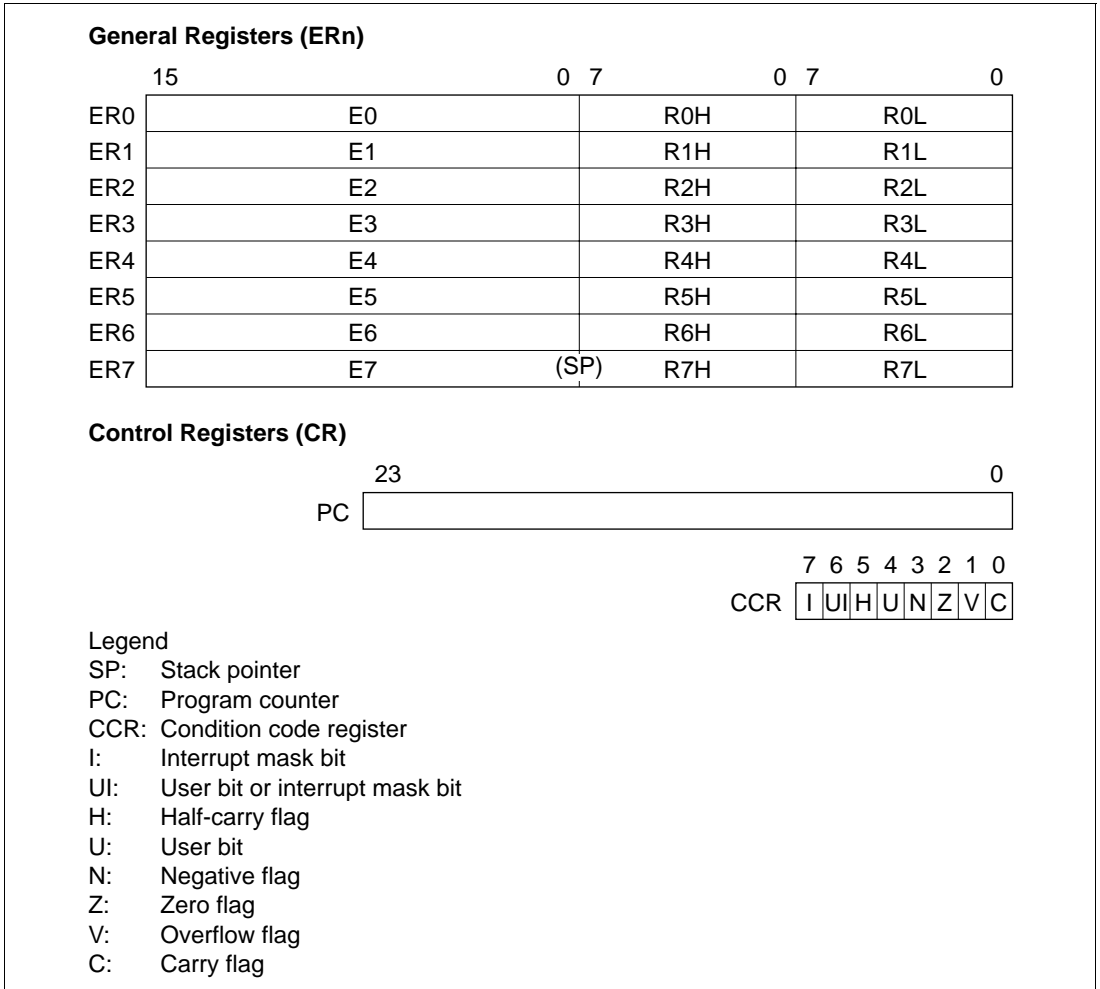


**Figure 2.2 Memory Map**

## 2.4 Register Configuration

### 2.4.1 Overview

The H8/300H CPU has the internal registers shown in figure 2.3. There are two types of registers: general registers and control registers.



**Figure 2.3 CPU Registers**

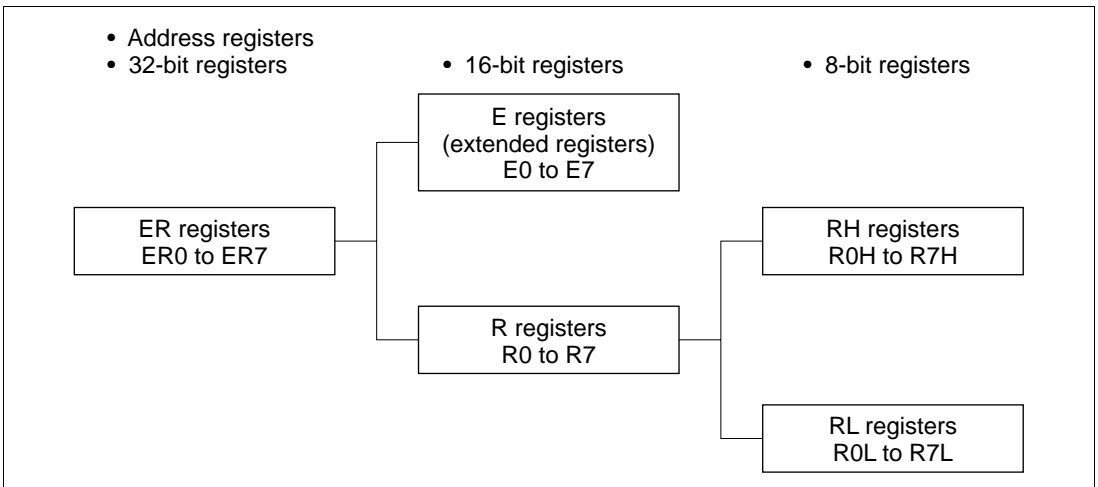
## 2.4.2 General Registers

The H8/300H CPU has eight 32-bit general registers. These general registers are all functionally alike and can be used without distinction between data registers and address registers. When a general register is used as a data register, it can be accessed as a 32-bit, 16-bit, or 8-bit register. When the general registers are used as 32-bit registers or as address registers, they are designated by the letters ER (ER0 to ER7).

The ER registers divide into 16-bit general registers designated by the letters E (E0 to E7) and R (R0 to R7). These registers are functionally equivalent, providing a maximum sixteen 16-bit registers. The E registers (E0 to E7) are also referred to as extended registers.

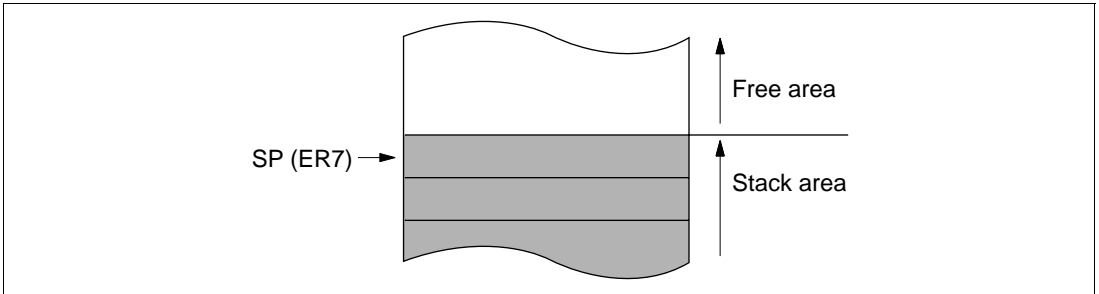
The R registers divide into 8-bit general registers designated by the letters RH (R0H to R7H) and RL (R0L to R7L). These registers are functionally equivalent, providing a maximum sixteen 8-bit registers.

Figure 2.4 illustrates the usage of the general registers. The usage of each register can be selected independently.



**Figure 2.4 Usage of General Registers**

General register ER7 has the function of stack pointer (SP) in addition to its general-register function, and is used implicitly in exception handling and subroutine calls. Figure 2.5 shows the stack.



**Figure 2.5 Stack**

### 2.4.3 Control Registers

The control registers are the 24-bit program counter (PC) and the 8-bit condition code register (CCR).

**Program Counter (PC):** This 24-bit counter indicates the address of the next instruction the CPU will execute. The length of all CPU instructions is 2 bytes (one word), so the least significant PC bit is ignored. When an instruction is fetched, the least significant PC bit is regarded as 0.

**Condition Code Register (CCR):** This 8-bit register contains internal CPU status information, including the interrupt mask bit (I) and half-carry (H), negative (N), zero (Z), overflow (V), and carry (C) flags.

**Bit 7—Interrupt Mask Bit (I):** Masks interrupts other than NMI when set to 1. NMI is accepted regardless of the I bit setting. The I bit is set to 1 at the start of an exception-handling sequence.

**Bit 6—User Bit or Interrupt Mask Bit (UI):** Can be written and read by software using the LDC, STC, ANDC, ORC, and XORC instructions. This bit can also be used as an interrupt mask bit. For details see section 5, Interrupt Controller.

**Bit 5—Half-Carry Flag (H):** When the ADD.B, ADDX.B, SUB.B, SUBX.B, CMP.B, or NEG.B instruction is executed, this flag is set to 1 if there is a carry or borrow at bit 3, and cleared to 0 otherwise. When the ADD.W, SUB.W, CMP.W, or NEG.W instruction is executed, the H flag is set to 1 if there is a carry or borrow at bit 11, and cleared to 0 otherwise. When the ADD.L, SUB.L, CMP.L, or NEG.L instruction is executed, the H flag is set to 1 if there is a carry or borrow at bit 27, and cleared to 0 otherwise.

**Bit 4—User Bit (U):** Can be written and read by software using the LDC, STC, ANDC, ORC, and XORC instructions.

**Bit 3—Negative Flag (N):** Stores the value of the most significant bit of data, regarded as the sign bit.

**Bit 2—Zero Flag (Z):** Set to 1 to indicate zero data, and cleared to 0 to indicate non-zero data.

**Bit 1—Overflow Flag (V):** Set to 1 when an arithmetic overflow occurs, and cleared to 0 at other times.

**Bit 0—Carry Flag (C):** Set to 1 when a carry is generated by execution of an operation, and cleared to 0 otherwise. Used by:

- Add instructions, to indicate a carry
- Subtract instructions, to indicate a borrow
- Shift and rotate instructions

The carry flag is also used as a bit accumulator by bit manipulation instructions.

Some instructions leave flag bits unchanged. Operations can be performed on CCR by the LDC, STC, ANDC, ORC, and XORC instructions. The N, Z, V, and C flags are used by conditional branch (Bcc) instructions.

For the action of each instruction on the flag bits, see appendix A.1, Instruction List. For the I and UI bits, see section 5, Interrupt Controller.

#### 2.4.4 Initial CPU Register Values

In reset exception handling, PC is initialized to a value loaded from the vector table, and the I bit in CCR is set to 1. The other CCR bits and the general registers are not initialized. In particular, the initial value of the stack pointer (ER7) is also undefined. The stack pointer (ER7) must therefore be initialized by an MOV.L instruction executed immediately after a reset.



## 2.5 Data Formats

The H8/300H CPU can process 1-bit, 4-bit (BCD), 8-bit (byte), 16-bit (word), and 32-bit (longword) data. Bit-manipulation instructions operate on 1-bit data by accessing bit  $n$  ( $n = 0, 1, 2, \dots, 7$ ) of byte operand data. The DAA and DAS decimal-adjust instructions treat byte data as two digits of 4-bit BCD data.

### 2.5.1 General Register Data Formats

Figures 2.6 and 2.7 show the data formats in general registers.

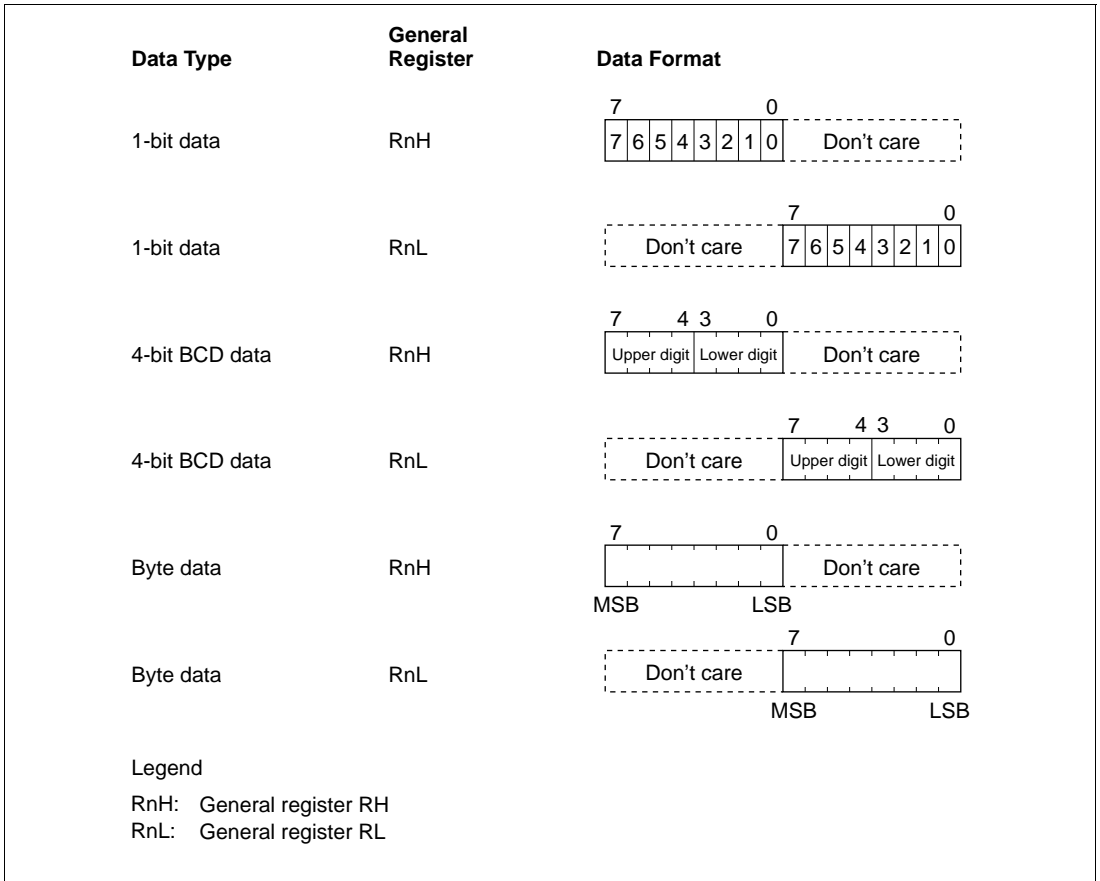
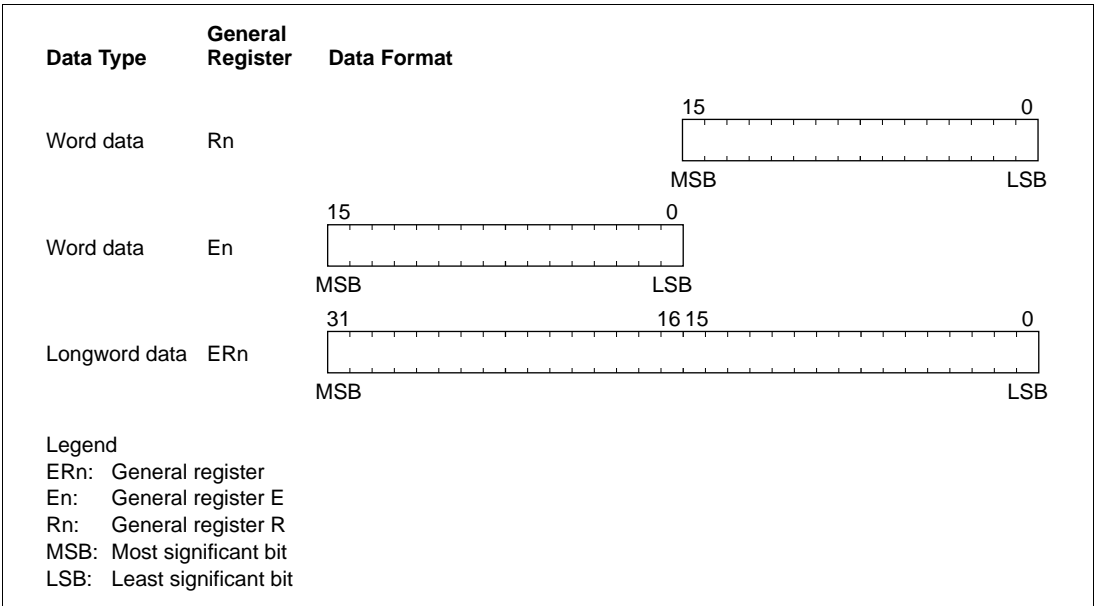


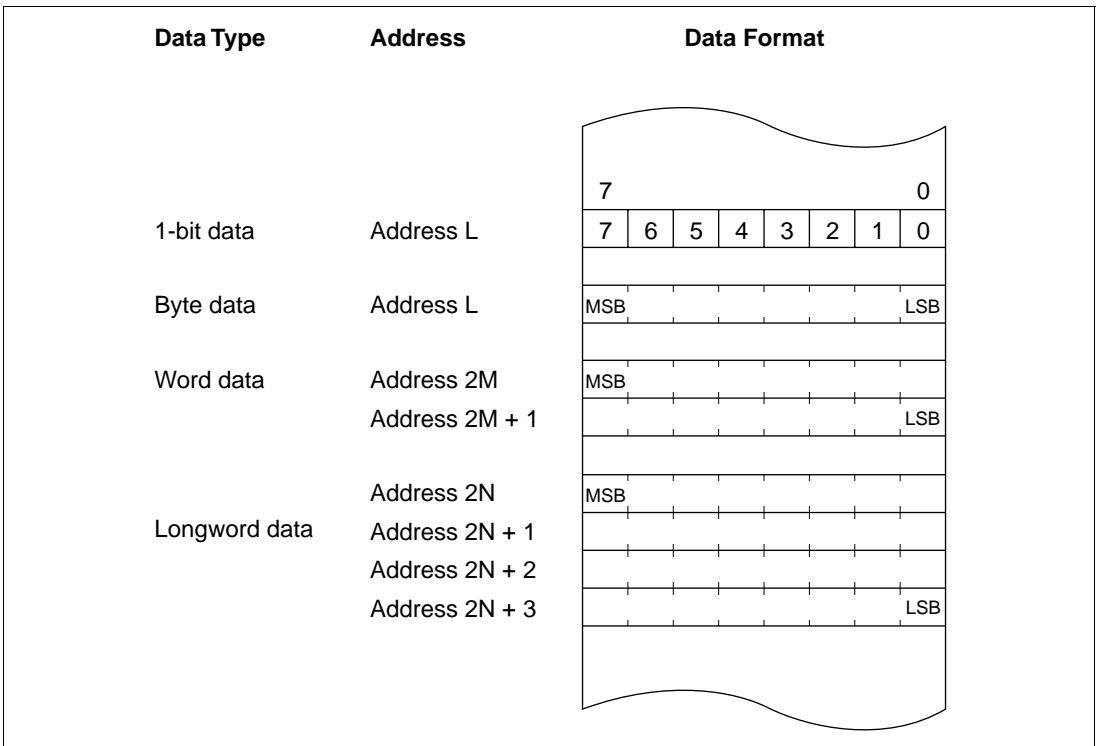
Figure 2.6 General Register Data Formats



**Figure 2.7 General Register Data Formats**

### 2.5.2 Memory Data Formats

Figure 2.8 shows the data formats on memory. The H8/300H CPU can access word data and longword data on memory, but word or longword data must begin at an even address. If an attempt is made to access word or longword data at an odd address, no address error occurs but the least significant bit of the address is regarded as 0, so the access starts at the preceding address. This also applies to instruction fetches.



**Figure 2.8 Memory Data Formats**

When ER7 (SP) is used as an address register to access the stack, the operand size should be word size or longword size.

## 2.6 Instruction Set

### 2.6.1 Instruction Set Overview

The H8/300H CPU has 62 types of instructions, which are classified in table 2.1.

**Table 2.1 Instruction Classification**

Function	Instruction	Types
Data transfer	MOV, PUSH* <sup>1</sup> , POP* <sup>1</sup> , MOVTPE* <sup>2</sup> , MOVFPE* <sup>2</sup>	3
Arithmetic operations	ADD, SUB, ADDX, SUBX, INC, DEC, ADDS, SUBS, DAA, DAS, MULXU, MULXS, DIVXU, DIVXS, CMP, NEG, EXTS, EXTU	18
Logic operations	AND, OR, XOR, NOT	4
Shift operations	SHAL, SHAR, SHLL, SHLR, ROTL, ROTR, ROTXL, ROTXR	8
Bit manipulation	BSET, BCLR, BNOT, BTST, BAND, BAND, BOR, BIOR, BXOR, BIXOR, BLD, BILD, BST, BIST	14
Branch	Bcc* <sup>3</sup> , JMP, BSR, JSR, RTS	5
System control	TRAPA, RTE, SLEEP, LDC, STC, ANDC, ORC, XORC, NOP	9
Block data transfer	EPMOV	1

Total 62 types

- Notes: 1. POP.W Rn is identical to MOV.W @SP+, Rn.  
PUSH.W Rn is identical to MOV.W Rn, @-SP.  
POP.L ERn is identical to MOV.L @SP+, Rn.  
PUSH.L ERn is identical to MOV.L Rn, @-SP.
2. Not available in the H8/3067 Series.
3. Bcc is a generic branching instruction.

## 2.6.2 Instructions and Addressing Modes

Table 2.2 indicates the instructions available in the H8/300H CPU.

**Table 2.2 Instructions and Addressing Modes**

Function	Instruction	#xx	Rn	Addressing Modes										
				@ERn	@(d:16, ERn)	@(d:24, ERn)	@ERn+/@-ERn	@aa:8	@aa:16	@aa:24	@(d:8, PC)	@(d:16, PC)	@@aa:8	—
Data transfer	MOV	BWL	BWL	BWL	BWL	BWL	BWL	B	BWL	BWL	—	—	—	—
	POP, PUSH	—	—	—	—	—	—	—	—	—	—	—	—	WL
	MOVFP, MOVTPE	—	—	—	—	—	—	—	—	—	—	—	—	—
Arithmetic operations	ADD, CMP	BWL	BWL	—	—	—	—	—	—	—	—	—	—	—
	SUB	WL	BWL	—	—	—	—	—	—	—	—	—	—	—
	ADDX, SUBX	B	B	—	—	—	—	—	—	—	—	—	—	—
	ADDS, SUBS	—	L	—	—	—	—	—	—	—	—	—	—	—
	INC, DEC	—	BWL	—	—	—	—	—	—	—	—	—	—	—
	DAA, DAS	—	B	—	—	—	—	—	—	—	—	—	—	—
	MULXU, MULXS, DIVXU, DIVXS	—	BW	—	—	—	—	—	—	—	—	—	—	—
	NEG	—	BWL	—	—	—	—	—	—	—	—	—	—	—
	EXTU, EXTS	—	WL	—	—	—	—	—	—	—	—	—	—	—
Logic operations	AND, OR, XOR	—	BWL	—	—	—	—	—	—	—	—	—	—	—
	NOT	—	BWL	—	—	—	—	—	—	—	—	—	—	—
Shift instructions	—	BWL	—	—	—	—	—	—	—	—	—	—	—	
Bit manipulation	—	B	B	—	—	—	B	—	—	—	—	—	—	
Branch	Bcc, BSR	—	—	—	—	—	—	—	—	—	—	—	—	—
	JMP, JSR	—	—	○	—	—	—	—	—	—	○	○	—	—
	RTS	—	—	—	—	—	—	—	—	○	—	—	○	—
System control	TRAPA	—	—	—	—	—	—	—	—	—	—	—	—	○
	RTE	—	—	—	—	—	—	—	—	—	—	—	—	○
	SLEEP	—	—	—	—	—	—	—	—	—	—	—	—	○
	LDC	B	B	W	W	W	W	—	W	W	—	—	—	○
	STC	—	B	W	W	W	W	—	W	W	—	—	—	—
	ANDC, ORC, XORC	B	—	—	—	—	—	—	—	—	—	—	—	—
NOP	—	—	—	—	—	—	—	—	—	—	—	—	○	
Block data transfer	—	—	—	—	—	—	—	—	—	—	—	—	—	BW

## 2.6.3 Tables of Instructions Classified by Function

Tables 2.3 to 2.10 summarize the instructions in each functional category. The operation notation used in these tables is defined next.

### Operation Notation

Rd	General register (destination)*
Rs	General register (source)*
Rn	General register*
ERn	General register (32-bit register or address register)
(EAd)	Destination operand
(EAs)	Source operand
CCR	Condition code register
N	N (negative) flag of CCR
Z	Z (zero) flag of CCR
V	V (overflow) flag of CCR
C	C (carry) flag of CCR
PC	Program counter
SP	Stack pointer
#IMM	Immediate data
disp	Displacement
+	Addition
–	Subtraction
×	Multiplication
÷	Division
^	AND logical
∨	OR logical
⊕	Exclusive OR logical
→	Move
¬	NOT (logical complement)
:3/:8/:16/:24	3-, 8-, 16-, or 24-bit length

Note: \* General registers include 8-bit registers (R0H to R7H, R0L to R7L), 16-bit registers (R0 to R7, E0 to E7), and 32-bit data or address registers (ER0 to ER7).

**Table 2.3 Data Transfer Instructions**

<b>Instruction</b>	<b>Size*</b>	<b>Function</b>
MOV	B/W/L	(EAs) → Rd, Rs → (EAd) Moves data between two general registers or between a general register and memory, or moves immediate data to a general register.
MOVFPE	B	(EAs) → Rd Cannot be used in this LSI.
MOVTPE	B	Rs → (EAs) Cannot be used in this LSI.
POP	W/L	@SP+ → Rn Pops a general register from the stack. POP.W Rn is identical to MOV.W @SP+, Rn. Similarly, POP.L ERn is identical to MOV.L @SP+, ERn.
PUSH	W/L	Rn → @-SP Pushes a general register onto the stack. PUSH.W Rn is identical to MOV.W Rn, @-SP. Similarly, PUSH.L ERn is identical to MOV.L ERn, @-SP.

Note: \* Size refers to the operand size.

B: Byte

W: Word

L: Longword

**Table 2.4 Arithmetic Operation Instructions**

<b>Instruction</b>	<b>Size*</b>	<b>Function</b>
ADD,SUB	B/W/L	$Rd \pm Rs \rightarrow Rd, Rd \pm \#IMM \rightarrow Rd$ Performs addition or subtraction on data in two general registers, or on immediate data and data in a general register. (Immediate byte data cannot be subtracted from data in a general register. Use the SUBX or ADD instruction.)
ADDX, SUBX	B	$Rd \pm Rs \pm C \rightarrow Rd, Rd \pm \#IMM \pm C \rightarrow Rd$ Performs addition or subtraction with carry or borrow on data in two general registers, or on immediate data and data in a general register.
INC, DEC	B/W/L	$Rd \pm 1 \rightarrow Rd, Rd \pm 2 \rightarrow Rd$ Increments or decrements a general register by 1 or 2. (Byte operands can be incremented or decremented by 1 only.)
ADDS, SUBS	L	$Rd \pm 1 \rightarrow Rd, Rd \pm 2 \rightarrow Rd, Rd \pm 4 \rightarrow Rd$ Adds or subtracts the value 1, 2, or 4 to or from data in a 32-bit register.
DAA, DAS	B	$Rd \text{ decimal adjust} \rightarrow Rd$ Decimal-adjusts an addition or subtraction result in a general register by referring to CCR to produce 4-bit BCD data.
MULXU	B/W	$Rd \times Rs \rightarrow Rd$ Performs unsigned multiplication on data in two general registers: either 8 bits $\times$ 8 bits $\rightarrow$ 16 bits or 16 bits $\times$ 16 bits $\rightarrow$ 32 bits.
MULXS	B/W	$Rd \times Rs \rightarrow Rd$ Performs signed multiplication on data in two general registers: either 8 bits $\times$ 8 bits $\rightarrow$ 16 bits or 16 bits $\times$ 16 bits $\rightarrow$ 32 bits.

Note: \* Size refers to the operand size.

B: Byte

W: Word

L: Longword



**Table 2.4 Arithmetic Operation Instructions (cont)**

<b>Instruction</b>	<b>Size*</b>	<b>Function</b>
DIVXU	B/W	$Rd \div Rs \rightarrow Rd$ Performs unsigned division on data in two general registers: either 16 bits $\div$ 8 bits $\rightarrow$ 8-bit quotient and 8-bit remainder or 32 bits $\div$ 16 bits $\rightarrow$ 16-bit quotient and 16-bit remainder
DIVXS	B/W	$Rd \div Rs \rightarrow Rd$ Performs signed division on data in two general registers: either 16 bits $\div$ 8 bits $\rightarrow$ 8-bit quotient and 8-bit remainder, or 32 bits $\div$ 16 bits $\rightarrow$ 16-bit quotient and 16-bit remainder
CMP	B/W/L	$Rd - Rs, Rd - \#IMM$ Compares data in a general register with data in another general register or with immediate data, and sets CCR according to the result.
NEG	B/W/L	$0 - Rd \rightarrow Rd$ Takes the two's complement (arithmetic complement) of data in a general register.
EXTS	W/L	$Rd$ (sign extension) $\rightarrow Rd$ Extends byte data in the lower 8 bits of a 16-bit register to word data, or extends word data in the lower 16 bits of a 32-bit register to longword data, by extending the sign bit.
EXTU	W/L	$Rd$ (zero extension) $\rightarrow Rd$ Extends byte data in the lower 8 bits of a 16-bit register to word data, or extends word data in the lower 16 bits of a 32-bit register to longword data, by padding with zeros.

Note: \* Size refers to the operand size.

B: Byte

W: Word

L: Longword

**Table 2.5 Logic Operation Instructions**

Instruction	Size*	Function
AND	B/W/L	$Rd \wedge Rs \rightarrow Rd$ , $Rd \wedge \#IMM \rightarrow Rd$ Performs a logical AND operation on a general register and another general register or immediate data.
OR	B/W/L	$Rd \vee Rs \rightarrow Rd$ , $Rd \vee \#IMM \rightarrow Rd$ Performs a logical OR operation on a general register and another general register or immediate data.
XOR	B/W/L	$Rd \oplus Rs \rightarrow Rd$ , $Rd \oplus \#IMM \rightarrow Rd$ Performs a logical exclusive OR operation on a general register and another general register or immediate data.
NOT	B/W/L	$\neg Rd \rightarrow Rd$ Takes the one's complement (logical complement) of general register contents.

Note: \* Size refers to the operand size.

B: Byte

W: Word

L: Longword

**Table 2.6 Shift Instructions**

Instruction	Size*	Function
SHAL, SHAR	B/W/L	$Rd \text{ (shift)} \rightarrow Rd$ Performs an arithmetic shift on general register contents.
SHLL, SHLR	B/W/L	$Rd \text{ (shift)} \rightarrow Rd$ Performs a logical shift on general register contents.
ROTL, ROTR	B/W/L	$Rd \text{ (rotate)} \rightarrow Rd$ Rotates general register contents.
ROTXL, ROTXR	B/W/L	$Rd \text{ (rotate)} \rightarrow Rd$ Rotates general register contents, including the carry bit.

Note: \* Size refers to the operand size.

B: Byte

W: Word

L: Longword

**Table 2.7 Bit Manipulation Instructions**

<b>Instruction</b>	<b>Size*</b>	<b>Function</b>
BSET	B	$1 \rightarrow (\text{<bit-No.> of <EAd>})$ Sets a specified bit in a general register or memory operand to 1. The bit number is specified by 3-bit immediate data or the lower 3 bits of a general register.
BCLR	B	$0 \rightarrow (\text{<bit-No.> of <EAd>})$ Clears a specified bit in a general register or memory operand to 0. The bit number is specified by 3-bit immediate data or the lower 3 bits of a general register.
BNOT	B	$\neg (\text{<bit-No.> of <EAd>}) \rightarrow (\text{<bit-No.> of <EAd>})$ Inverts a specified bit in a general register or memory operand. The bit number is specified by 3-bit immediate data or the lower 3 bits of a general register.
BTST	B	$\neg (\text{<bit-No.> of <EAd>}) \rightarrow Z$ Tests a specified bit in a general register or memory operand and sets or clears the Z flag accordingly. The bit number is specified by 3-bit immediate data or the lower 3 bits of a general register.
BAND	B	$C \wedge (\text{<bit-No.> of <EAd>}) \rightarrow C$ ANDs the carry flag with a specified bit in a general register or memory operand and stores the result in the carry flag.
BIAND	B	$C \wedge [\neg (\text{<bit-No.> of <EAd>})] \rightarrow C$ ANDs the carry flag with the inverse of a specified bit in a general register or memory operand and stores the result in the carry flag. The bit number is specified by 3-bit immediate data.

Note: \* Size refers to the operand size.

B: Byte

**Table 2.7 Bit Manipulation Instructions (cont)**

<b>Instruction</b>	<b>Size*</b>	<b>Function</b>
BOR	B	$C \vee (\text{<bit-No.> of <EAd>}) \rightarrow C$ ORs the carry flag with a specified bit in a general register or memory operand and stores the result in the carry flag.
BIOR	B	$C \vee [\neg (\text{<bit-No.> of <EAd>})] \rightarrow C$ ORs the carry flag with the inverse of a specified bit in a general register or memory operand and stores the result in the carry flag. The bit number is specified by 3-bit immediate data.
BXOR	B	$C \oplus (\text{<bit-No.> of <EAd>}) \rightarrow C$ Exclusive-ORs the carry flag with a specified bit in a general register or memory operand and stores the result in the carry flag.
BIXOR	B	$C \oplus [\neg (\text{<bit-No.> of <EAd>})] \rightarrow C$ Exclusive-ORs the carry flag with the inverse of a specified bit in a general register or memory operand and stores the result in the carry flag. The bit number is specified by 3-bit immediate data.
BLD	B	$(\text{<bit-No.> of <EAd>}) \rightarrow C$ Transfers a specified bit in a general register or memory operand to the carry flag.
BILD	B	$\neg (\text{<bit-No.> of <EAd>}) \rightarrow C$ Transfers the inverse of a specified bit in a general register or memory operand to the carry flag. The bit number is specified by 3-bit immediate data.
BST	B	$C \rightarrow (\text{<bit-No.> of <EAd>})$ Transfers the carry flag value to a specified bit in a general register or memory operand.
BIST	B	$C \rightarrow \neg (\text{<bit-No.> of <EAd>})$ Transfers the inverse of the carry flag value to a specified bit in a general register or memory operand. The bit number is specified by 3-bit immediate data.

Note: \* Size refers to the operand size.

B: Byte

**Table 2.8 Branching Instructions**

<b>Instruction</b>	<b>Size</b>	<b>Function</b>																																																			
Bcc	—	Branches to a specified address if address specified condition is met. The branching conditions are listed below.																																																			
		<table border="1"> <thead> <tr> <th><b>Mnemonic</b></th> <th><b>Description</b></th> <th><b>Condition</b></th> </tr> </thead> <tbody> <tr> <td>BRA (BT)</td> <td>Always (true)</td> <td>Always</td> </tr> <tr> <td>BRN (BF)</td> <td>Never (false)</td> <td>Never</td> </tr> <tr> <td>BHI</td> <td>High</td> <td><math>C \vee Z = 0</math></td> </tr> <tr> <td>BLS</td> <td>Low or same</td> <td><math>C \vee Z = 1</math></td> </tr> <tr> <td>Bcc (BHS)</td> <td>Carry clear (high or same)</td> <td><math>C = 0</math></td> </tr> <tr> <td>BCS (BLO)</td> <td>Carry set (low)</td> <td><math>C = 1</math></td> </tr> <tr> <td>BNE</td> <td>Not equal</td> <td><math>Z = 0</math></td> </tr> <tr> <td>BEQ</td> <td>Equal</td> <td><math>Z = 1</math></td> </tr> <tr> <td>BVC</td> <td>Overflow clear</td> <td><math>V = 0</math></td> </tr> <tr> <td>BVS</td> <td>Overflow set</td> <td><math>V = 1</math></td> </tr> <tr> <td>BPL</td> <td>Plus</td> <td><math>N = 0</math></td> </tr> <tr> <td>BMI</td> <td>Minus</td> <td><math>N = 1</math></td> </tr> <tr> <td>BGE</td> <td>Greater or equal</td> <td><math>N \oplus V = 0</math></td> </tr> <tr> <td>BLT</td> <td>Less than</td> <td><math>N \oplus V = 1</math></td> </tr> <tr> <td>BGT</td> <td>Greater than</td> <td><math>Z \vee (N \oplus V) = 0</math></td> </tr> <tr> <td>BLE</td> <td>Less or equal</td> <td><math>Z \vee (N \oplus V) = 1</math></td> </tr> </tbody> </table>	<b>Mnemonic</b>	<b>Description</b>	<b>Condition</b>	BRA (BT)	Always (true)	Always	BRN (BF)	Never (false)	Never	BHI	High	$C \vee Z = 0$	BLS	Low or same	$C \vee Z = 1$	Bcc (BHS)	Carry clear (high or same)	$C = 0$	BCS (BLO)	Carry set (low)	$C = 1$	BNE	Not equal	$Z = 0$	BEQ	Equal	$Z = 1$	BVC	Overflow clear	$V = 0$	BVS	Overflow set	$V = 1$	BPL	Plus	$N = 0$	BMI	Minus	$N = 1$	BGE	Greater or equal	$N \oplus V = 0$	BLT	Less than	$N \oplus V = 1$	BGT	Greater than	$Z \vee (N \oplus V) = 0$	BLE	Less or equal	$Z \vee (N \oplus V) = 1$
<b>Mnemonic</b>	<b>Description</b>	<b>Condition</b>																																																			
BRA (BT)	Always (true)	Always																																																			
BRN (BF)	Never (false)	Never																																																			
BHI	High	$C \vee Z = 0$																																																			
BLS	Low or same	$C \vee Z = 1$																																																			
Bcc (BHS)	Carry clear (high or same)	$C = 0$																																																			
BCS (BLO)	Carry set (low)	$C = 1$																																																			
BNE	Not equal	$Z = 0$																																																			
BEQ	Equal	$Z = 1$																																																			
BVC	Overflow clear	$V = 0$																																																			
BVS	Overflow set	$V = 1$																																																			
BPL	Plus	$N = 0$																																																			
BMI	Minus	$N = 1$																																																			
BGE	Greater or equal	$N \oplus V = 0$																																																			
BLT	Less than	$N \oplus V = 1$																																																			
BGT	Greater than	$Z \vee (N \oplus V) = 0$																																																			
BLE	Less or equal	$Z \vee (N \oplus V) = 1$																																																			
JMP	—	Branches unconditionally to a specified address																																																			
BSR	—	Branches to a subroutine at a specified address																																																			
JSR	—	Branches to a subroutine at a specified address																																																			
RTS	—	Returns from a subroutine																																																			

**Table 2.9 System Control Instructions**

<b>Instruction</b>	<b>Size*</b>	<b>Function</b>
TRAPA	—	Starts trap-instruction exception handling
RTE	—	Returns from an exception-handling routine
SLEEP	—	Causes a transition to the power-down state
LDC	B/W	(EAs) → CCR Moves the source operand contents to the condition code register. The condition code register size is one byte, but in transfer from memory, data is read by word access.
STC	B/W	CCR → (EAd) Transfers the CCR contents to a destination location. The condition code register size is one byte, but in transfer to memory, data is written by word access.
ANDC	B	CCR ∧ #IMM → CCR Logically ANDs the condition code register with immediate data.
ORC	B	CCR ∨ #IMM → CCR Logically ORs the condition code register with immediate data.
XORC	B	CCR ⊕ #IMM → CCR Logically exclusive-ORs the condition code register with immediate data.
NOP	—	PC + 2 → PC Only increments the program counter.

Note: \* Size refers to the operand size.

B: Byte

W: Word

**Table 2.10 Block Transfer Instruction**

Instruction	Size	Function
EEPMOV.B	—	if R4L 0 then repeat @ER5+ → @ER6+, R4L – 1 → R4L until R4L = 0 else next;
EEPMOV.W	—	if R4 0 then repeat @ER5+ → @ER6+, R4 – 1 → R4 until R4 = 0 else next;  Block transfer instruction. This instruction transfers the number of data bytes specified by R4L or R4, starting from the address indicated by ER5, to the location starting at the address indicated by ER6. At the end of the transfer, the next instruction is executed.

### 2.6.4 Basic Instruction Formats

The H8/300H instructions consist of 2-byte (1-word) units. An instruction consists of an operation field (OP field), a register field (r field), an effective address extension (EA field), and a condition field (cc).

**Operation Field:** Indicates the function of the instruction, the addressing mode, and the operation to be carried out on the operand. The operation field always includes the first 4 bits of the instruction. Some instructions have two operation fields.

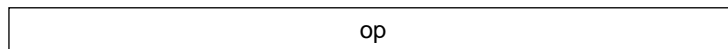
**Register Field:** Specifies a general register. Address registers are specified by 3 bits, data registers by 3 bits or 4 bits. Some instructions have two register fields. Some have no register field.

**Effective Address Extension:** Eight, 16, or 32 bits specifying immediate data, an absolute address, or a displacement. A 24-bit address or displacement is treated as 32-bit data in which the first 8 bits are 0 (H'00).

**Condition Field:** Specifies the branching condition of Bcc instructions.

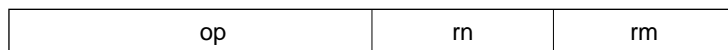
Figure 2.9 shows examples of instruction formats.

Operation field only



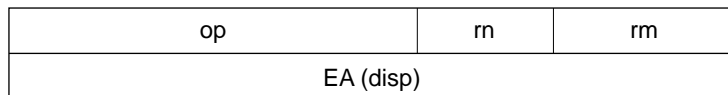
NOP, RTS, etc.

Operation field and register fields



ADD.B Rn, Rm, etc.

Operation field, register fields, and effective address extension



MOV.B @(d:16, Rn), Rm

Operation field, effective address extension, and condition field



BRA d:8

**Figure 2.9 Instruction Formats**



## 2.6.5 Notes on Use of Bit Manipulation Instructions

The BSET, BCLR, BNOT, BST, and BIST instructions read a byte of data, modify a bit in the byte, then write the byte back. Care is required when these instructions are used to access registers with write-only bits, or to access ports.

Step		Description
1	Read	Read one data byte at the specified address
2	Modify	Modify one bit in the data byte
3	Write	Write the modified data byte back to the specified address

**Example 1:** BCLR is executed to clear bit 0 in the port 4 data direction register (P4DDR) under the following conditions.

P4<sub>7</sub>, P4<sub>6</sub>: Input pins

P4<sub>5</sub> – P4<sub>0</sub>: Output pins

The intended purpose of this BCLR instruction is to switch P4<sub>0</sub> from output to input.

### Before Execution of BCLR Instruction

	P4 <sub>7</sub>	P4 <sub>6</sub>	P4 <sub>5</sub>	P4 <sub>4</sub>	P4 <sub>3</sub>	P4 <sub>2</sub>	P4 <sub>1</sub>	P4 <sub>0</sub>
Input/output	Input	Input	Output	Output	Output	Output	Output	Output
DDR	0	0	1	1	1	1	1	1

### Execution of BCLR Instruction

BCLR #0, @P4DDR ;Clear bit 0 in data direction register

## After Execution of BCLR Instruction

	P4 <sub>7</sub>	P4 <sub>6</sub>	P4 <sub>5</sub>	P4 <sub>4</sub>	P4 <sub>3</sub>	P4 <sub>2</sub>	P4 <sub>1</sub>	P4 <sub>0</sub>
Input/output	Output	Output	Output	Output	Output	Output	Output	Input
DDR	1	1	1	1	1	1	1	0

**Explanation:** To execute the BCLR instruction, the CPU begins by reading P4DDR. Since P4DDR is a write-only register, it is read as H'FF, even though its true value is H'3F.

Next the CPU clears bit 0 of the read data, changing the value to H'FE.

Finally, the CPU writes this value (H'FE) back to P4DDR to complete the BCLR instruction.

As a result, P4<sub>0</sub>DDR is cleared to 0, making P4<sub>0</sub> an input pin. In addition, P4<sub>7</sub>DDR and P4<sub>6</sub>DDR are set to 1, making P4<sub>7</sub> and P4<sub>6</sub> output pins.

The BCLR instruction can be used to clear flags in the on-chip registers to 0. In an interrupt-handling routine, for example, if it is known that the flag is set to 1, it is not necessary to read the flag ahead of time.

## 2.7 Addressing Modes and Effective Address Calculation

### 2.7.1 Addressing Modes

The H8/300H CPU supports the eight addressing modes listed in table 2.11. Each instruction uses a subset of these addressing modes. Arithmetic and logic instructions can use the register direct and immediate modes. Data transfer instructions can use all addressing modes except program-counter relative and memory indirect. Bit manipulation instructions use register direct, register indirect, or absolute (@aa:8) addressing mode to specify an operand, and register direct (BSET, BCLR, BNOT, and BTST instructions) or immediate (3-bit) addressing mode to specify a bit number in the operand.

**Table 2.11 Addressing Modes**

No.	Addressing Mode	Symbol
1	Register direct	Rn
2	Register indirect	@ERn
3	Register indirect with displacement	@(d:16, ERn)/@(d:24, ERn)
4	Register indirect with post-increment Register indirect with pre-decrement	@ERn+ @-ERn
5	Absolute address	@aa:8/@aa:16/@aa:24
6	Immediate	#xx:8/#xx:16/#xx:32
7	Program-counter relative	@(d:8, PC)/@(d:16, PC)
8	Memory indirect	@@aa:8

**1 Register Direct—Rn:** The register field of the instruction code specifies an 8-, 16-, or 32-bit register containing the operand. R0H to R7H and R0L to R7L can be specified as 8-bit registers. R0 to R7 and E0 to E7 can be specified as 16-bit registers. ER0 to ER7 can be specified as 32-bit registers.

**2 Register Indirect—@ERn:** The register field of the instruction code specifies an address register (ERn), the lower 24 bits of which contain the address of the operand.

**3 Register Indirect with Displacement—@(d:16, ERn) or @(d:24, ERn):** A 16-bit or 24-bit displacement contained in the instruction code is added to the contents of an address register (ERn) specified by the register field of the instruction, and the lower 24 bits of the sum specify the address of a memory operand. A 16-bit displacement is sign-extended when added.

#### 4 Register Indirect with Post-Increment or Pre-Decrement—@ERn+ or @-ERn:

- Register indirect with post-increment—@ERn+

The register field of the instruction code specifies an address register (ERn) the lower 24 bits of which contain the address of a memory operand. After the operand is accessed, 1, 2, or 4 is added to the address register contents (32 bits) and the sum is stored in the address register. The value added is 1 for byte access, 2 for word access, or 4 for longword access. For word or longword access, the register value should be even.

- Register indirect with pre-decrement—@-ERn

The value 1, 2, or 4 is subtracted from an address register (ERn) specified by the register field in the instruction code, and the lower 24 bits of the result become the address of a memory operand. The result is also stored in the address register. The value subtracted is 1 for byte access, 2 for word access, or 4 for longword access. For word or longword access, the resulting register value should be even.

**5 Absolute Address—@aa:8, @aa:16, or @aa:24:** The instruction code contains the absolute address of a memory operand. The absolute address may be 8 bits long (@aa:8), 16 bits long (@aa:16), or 24 bits long (@aa:24). For an 8-bit absolute address, the upper 16 bits are all assumed to be 1 (H'FFFF). For a 16-bit absolute address the upper 8 bits are a sign extension. A 24-bit absolute address can access the entire address space. Table 2.12 indicates the accessible address ranges.

**Table 2.12 Absolute Address Access Ranges**

<b>Absolute Address</b>	<b>1-Mbyte Modes</b>	<b>16-Mbyte Modes</b>
8 bits (@aa:8)	H'FFF00 to H'FFFFFF (1048320 to 1048575)	H'FFFF00 to H'FFFFFFF (16776960 to 16777215)
16 bits (@aa:16)	H'00000 to H'07FFF, H'F8000 to H'FFFFFF (0 to 32767, 1015808 to 1048575)	H'000000 to H'007FFF, H'FF8000 to H'FFFFFFF (0 to 32767, 16744448 to 16777215)
24 bits (@aa:24)	H'00000 to H'FFFFFF (0 to 1048575)	H'000000 to H'FFFFFFF (0 to 16777215)

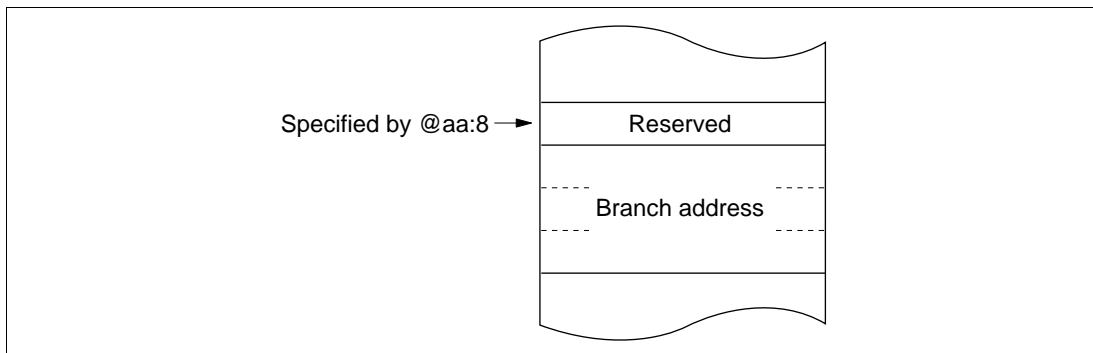
**6 Immediate—#xx:8, #xx:16, or #xx:32:** The instruction code contains 8-bit (#xx:8), 16-bit (#xx:16), or 32-bit (#xx:32) immediate data as an operand.

The instruction codes of the ADDS, SUBS, INC, and DEC instructions contain immediate data implicitly. The instruction codes of some bit manipulation instructions contain 3-bit immediate data specifying a bit number. The TRAPA instruction code contains 2-bit immediate data specifying a vector address.

**7 Program-Counter Relative—@(d:8, PC) or @(d:16, PC):** This mode is used in the Bcc and BSR instructions. An 8-bit or 16-bit displacement contained in the instruction code is sign-48

extended to 24 bits and added to the 24-bit PC contents to generate a 24-bit branch address. The PC value to which the displacement is added is the address of the first byte of the next instruction, so the possible branching range is  $-126$  to  $+128$  bytes ( $-63$  to  $+64$  words) or  $-32766$  to  $+32768$  bytes ( $-16383$  to  $+16384$  words) from the branch instruction. The resulting value should be an even number.

**8 Memory Indirect—@@aa:8:** This mode can be used by the JMP and JSR instructions. The instruction code contains an 8-bit absolute address specifying a memory operand. This memory operand contains a branch address. The memory operand is accessed by longword access. The first byte of the memory operand is ignored, generating a 24-bit branch address. See figure 2.10. The upper bits of the 8-bit absolute address are assumed to be 0 (H'0000), so the address range is 0 to 255 (H'000000 to H'0000FF). Note that the first part of this range is also the exception vector area. For further details see section 5, Interrupt Controller.



**Figure 2.10 Memory-Indirect Branch Address Specification**

When a word-size or longword-size memory operand is specified, or when a branch address is specified, if the specified memory address is odd, the least significant bit is regarded as 0. The accessed data or instruction code therefore begins at the preceding address. See section 2.5.2, Memory Data Formats.

## 2.7.2 Effective Address Calculation

Table 2.13 explains how an effective address is calculated in each addressing mode. In the 1-Mbyte operating modes the upper 4 bits of the calculated address are ignored in order to generate a 20-bit effective address.

Table 2.13 Effective Address Calculation

No.	Addressing Mode and Instruction Format	Effective Address Calculation	Effective Address
1	Register indirect (Rn) <div style="display: flex; align-items: center; gap: 5px;"> <div style="border: 1px solid black; padding: 2px 5px;">op</div> <div style="border: 1px solid black; padding: 2px 5px;">rm</div> <div style="border: 1px solid black; padding: 2px 5px;">rn</div> </div>		Operand is general register contents
2	Register indirect with displacement (@ERn) <div style="display: flex; align-items: center; gap: 5px;"> <div style="border: 1px solid black; padding: 2px 5px;">op</div> <div style="border: 1px solid black; padding: 2px 5px;">r</div> <div style="border: 1px solid black; padding: 2px 5px;"> </div> </div>		<div style="display: flex; align-items: center; gap: 5px;"> <div style="border: 1px solid black; padding: 2px 5px;">0</div> <div style="border: 1px solid black; padding: 2px 5px;">23</div> </div>
3	Register indirect with displacement @({d:16, ERn})/({d:24, ERn}) <div style="display: flex; align-items: center; gap: 5px;"> <div style="border: 1px solid black; padding: 2px 5px;">op</div> <div style="border: 1px solid black; padding: 2px 5px;">r</div> <div style="border: 1px solid black; padding: 2px 5px;"> </div> </div>		<div style="display: flex; align-items: center; gap: 5px;"> <div style="border: 1px solid black; padding: 2px 5px;">0</div> <div style="border: 1px solid black; padding: 2px 5px;">23</div> </div>
4	Register indirect with post-increment or pre-decrement Register indirect with post-increment @ERn+ <div style="display: flex; align-items: center; gap: 5px;"> <div style="border: 1px solid black; padding: 2px 5px;">op</div> <div style="border: 1px solid black; padding: 2px 5px;">r</div> <div style="border: 1px solid black; padding: 2px 5px;"> </div> </div> Register indirect with pre-decrement @-ERn <div style="display: flex; align-items: center; gap: 5px;"> <div style="border: 1px solid black; padding: 2px 5px;">op</div> <div style="border: 1px solid black; padding: 2px 5px;">r</div> <div style="border: 1px solid black; padding: 2px 5px;"> </div> </div>		<div style="display: flex; align-items: center; gap: 5px;"> <div style="border: 1px solid black; padding: 2px 5px;">0</div> <div style="border: 1px solid black; padding: 2px 5px;">23</div> </div>

1 for a byte operand,  
 2 for a word operand,  
 4 for a longword operand

**Table 2.13 Effective Address Calculation (cont)**

No.	Addressing Mode and Instruction Format	Effective Address Calculation	Effective Address
5	Absolute address @aa:8		
	@aa:16		
	@aa:24		
6	Immediate #xx:8, #xx:16, or #xx:32		<p>Operand is immediate data</p>
7	Program-counter relative @(d:8, PC) or @(d:16, PC)		

**Table 2.13 Effective Address Calculation (cont)**

No.	Addressing Mode and Instruction Format	Effective Address Calculation	Effective Address
8	Memory indirect @@aa:8	<p>Normal mode</p>	
	Advanced mode		

**Legend**

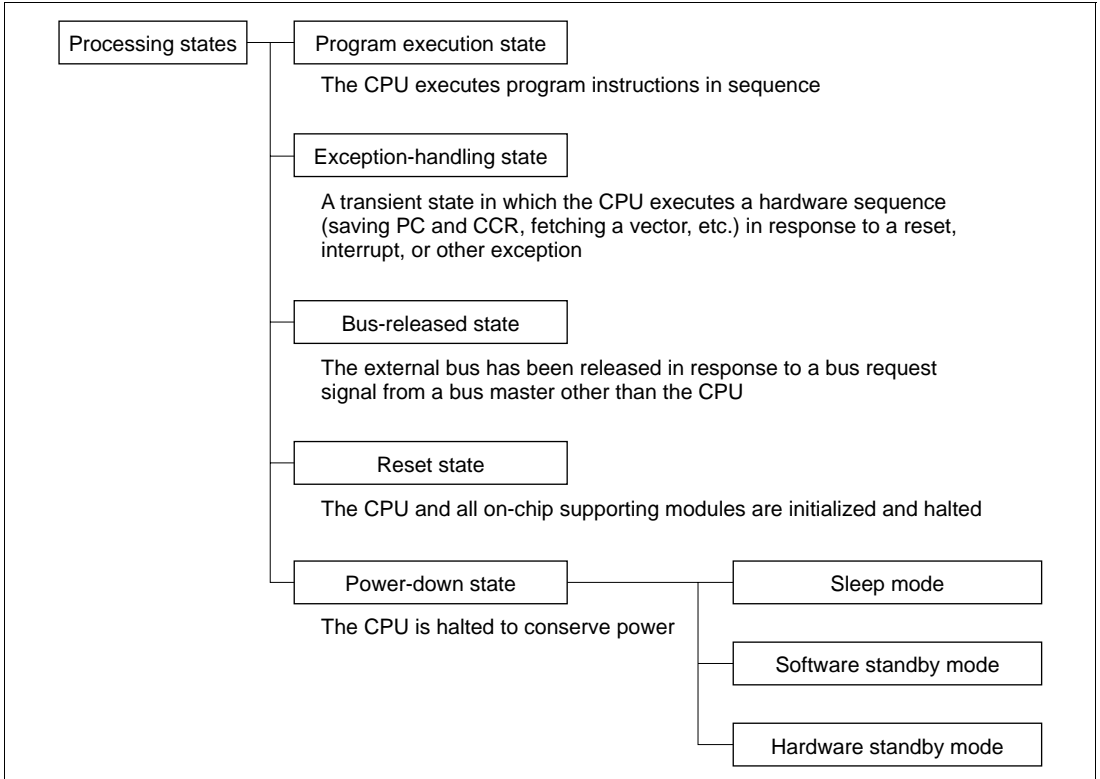
- r, rm, rn: Register field
- op: Operation field
- disp: Displacement
- IMM: Immediate data
- abs: Absolute address



## 2.8 Processing States

### 2.8.1 Overview

The H8/300H CPU has five processing states: the program execution state, exception-handling state, power-down state, reset state, and bus-released state. The power-down state includes sleep mode, software standby mode, and hardware standby mode. Figure 2.11 classifies the processing states. Figure 2.13 indicates the state transitions.



**Figure 2.11 Processing States**

## 2.8.2 Program Execution State

In this state the CPU executes program instructions in normal sequence.

## 2.8.3 Exception-Handling State

The exception-handling state is a transient state that occurs when the CPU alters the normal program flow due to a reset, interrupt, or trap instruction. The CPU fetches a starting address from the exception vector table and branches to that address. In interrupt and trap exception handling the CPU references the stack pointer (ER7) and saves the program counter and condition code register.

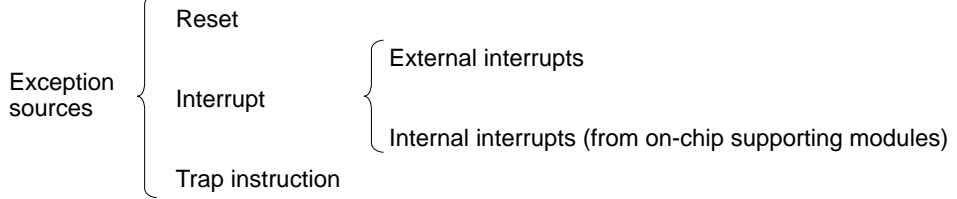
**Types of Exception Handling and Their Priority:** Exception handling is performed for resets, interrupts, and trap instructions. Table 2.14 indicates the types of exception handling and their priority. Trap instruction exceptions are accepted at all times in the program execution state.

**Table 2.14 Exception Handling Types and Priority**

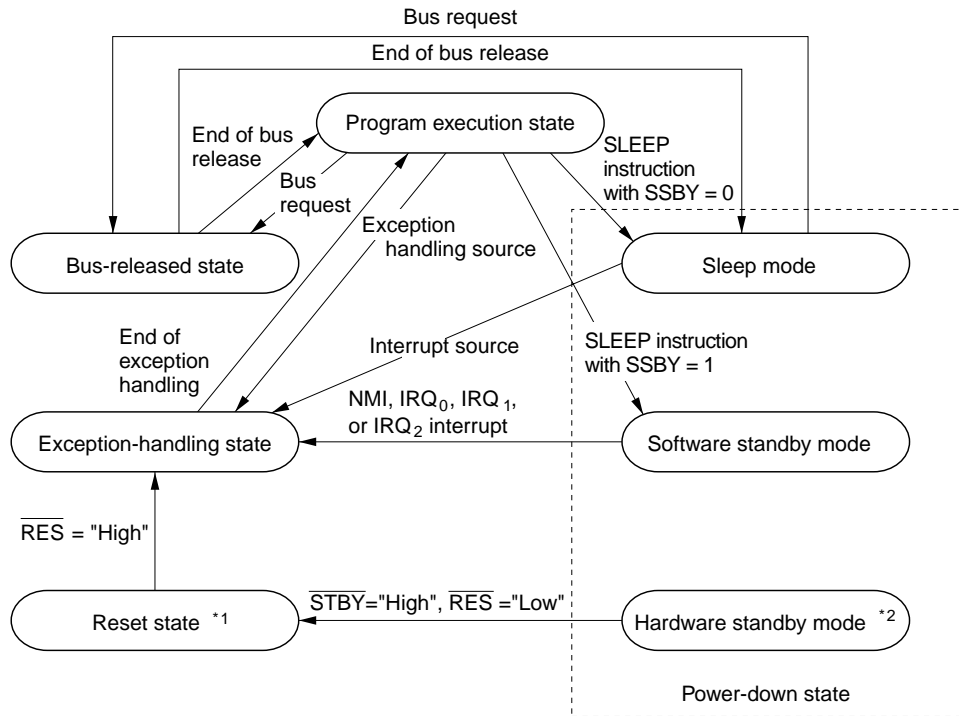
Priority	Type of Exception	Detection Timing	Start of Exception Handling
High ↑	Reset	Synchronized with clock	Exception handling starts immediately when $\overline{RES}$ changes from low to high
	Interrupt	End of instruction execution or end of exception handling*	When an interrupt is requested, exception handling starts at the end of the current instruction or current exception-handling sequence
	Trap instruction	When TRAPA instruction is executed	Exception handling starts when a trap (TRAPA) instruction is executed
Low			

Note: \* Interrupts are not detected at the end of the ANDC, ORC, XORC, and LDC instructions, or immediately after reset exception handling.

Figure 2.12 classifies the exception sources. For further details about exception sources, vector numbers, and vector addresses, see section 4, Exception Handling, and section 5, Interrupt Controller.



**Figure 2.12 Classification of Exception Sources**



- Notes:
1. From any state except hardware standby mode, a transition to the reset state occurs whenever  $\overline{RES}$  goes low.
  2. From any state, a transition to hardware standby mode occurs when  $\overline{STBY}$  goes low.

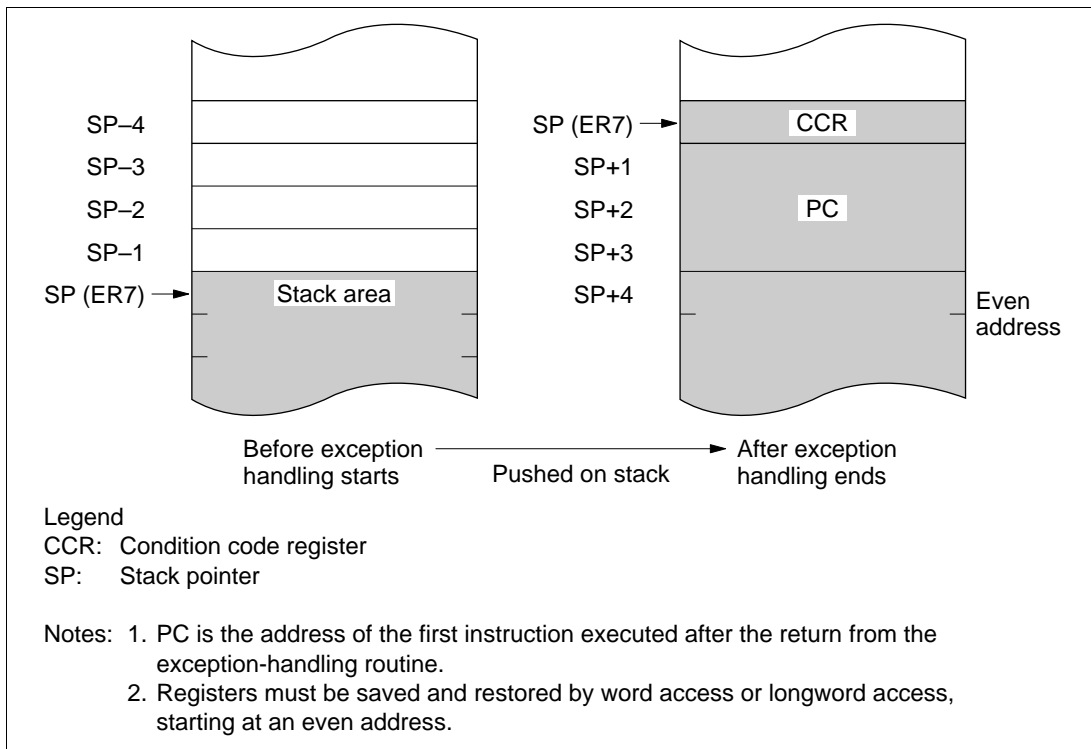
**Figure 2.13 State Transitions**

## 2.8.4 Exception-Handling Sequences

**Reset Exception Handling:** Reset exception handling has the highest priority. The reset state is entered when the  $\overline{\text{RES}}$  signal goes low. Reset exception handling starts after that, when  $\overline{\text{RES}}$  changes from low to high. When reset exception handling starts the CPU fetches a start address from the exception vector table and starts program execution from that address. All interrupts, including NMI, are disabled during the reset exception-handling sequence and immediately after it ends.

**Interrupt Exception Handling and Trap Instruction Exception Handling:** When these exception-handling sequences begin, the CPU references the stack pointer (ER7) and pushes the program counter and condition code register on the stack. Next, if the UE bit in the system control register (SYSCR) is set to 1, the CPU sets the I bit in the condition code register to 1. If the UE bit is cleared to 0, the CPU sets both the I bit and the UI bit in the condition code register to 1. Then the CPU fetches a start address from the exception vector table and execution branches to that address.

Figure 2.14 shows the stack after the exception-handling sequence.



**Figure 2.14 Stack Structure after Exception Handling**

## 2.8.5 Bus-Released State

In this state the bus is released to a bus master other than the CPU, in response to a bus request. The bus masters other than the CPU are the DMA controller, the DRAM interface, and an external bus master. While the bus is released, the CPU halts except for internal operations. Interrupt requests are not accepted. For details see section 6.11, Bus Arbiter.

## 2.8.6 Reset State

When the  $\overline{\text{RES}}$  input goes low all current processing stops and the CPU enters the reset state. The I bit in the condition code register is set to 1 by a reset. All interrupts are masked in the reset state. Reset exception handling starts when the  $\overline{\text{RES}}$  signal changes from low to high.

The reset state can also be entered by a watchdog timer overflow. For details see section 12, Watchdog Timer.

## 2.8.7 Power-Down State

In the power-down state the CPU stops operating to conserve power. There are three modes: sleep mode, software standby mode, and hardware standby mode.

**Sleep Mode:** A transition to sleep mode is made if the SLEEP instruction is executed while the SSBY bit is cleared to 0 in the system control register (SYSCR). CPU operations stop immediately after execution of the SLEEP instruction, but the contents of CPU registers are retained.

**Software Standby Mode:** A transition to software standby mode is made if the SLEEP instruction is executed while the SSBY bit is set to 1 in SYSCR. The CPU and clock halt and all on-chip supporting modules stop operating. The on-chip supporting modules are reset, but as long as a specified voltage is supplied the contents of CPU registers and on-chip RAM are retained. The I/O ports also remain in their existing states.

**Hardware Standby Mode:** A transition to hardware standby mode is made when the  $\overline{\text{STBY}}$  input goes low. As in software standby mode, the CPU and all clocks halt and the on-chip supporting modules are reset, but as long as a specified voltage is supplied, on-chip RAM contents are retained.

For further information see section 20, Power-Down State.

## 2.9 Basic Operational Timing

### 2.9.1 Overview

The H8/300H CPU operates according to the system clock ( $\phi$ ). The interval from one rise of the system clock to the next rise is referred to as a “state.” A memory cycle or bus cycle consists of two or three states. The CPU uses different methods to access on-chip memory, the on-chip supporting modules, and the external address space. Access to the external address space can be controlled by the bus controller.

### 2.9.2 On-Chip Memory Access Timing

On-chip memory is accessed in two states. The data bus is 16 bits wide, permitting both byte and word access. Figure 2.15 shows the on-chip memory access cycle. Figure 2.16 indicates the pin states.

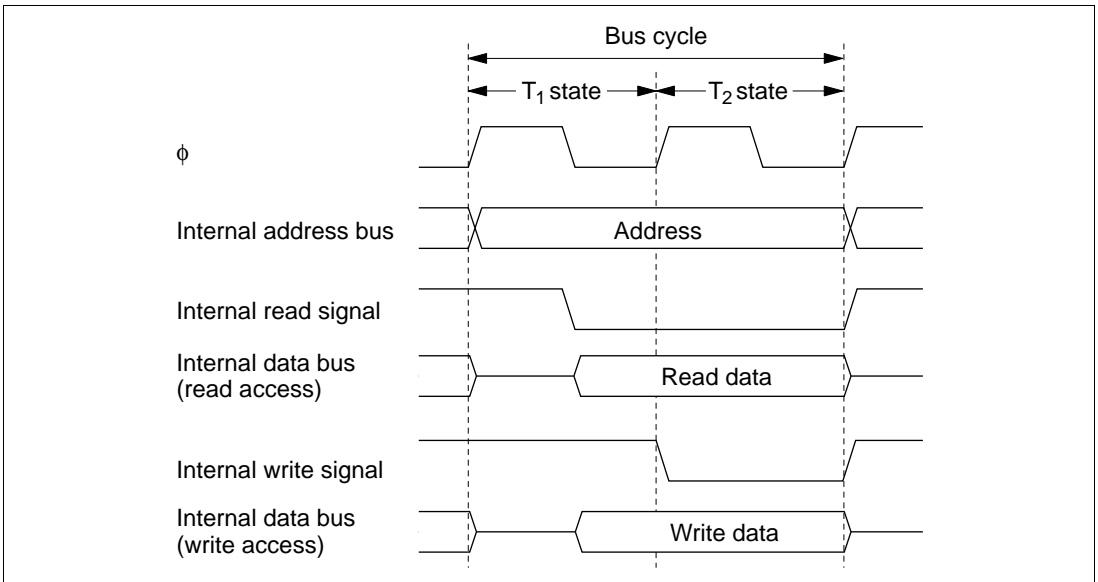
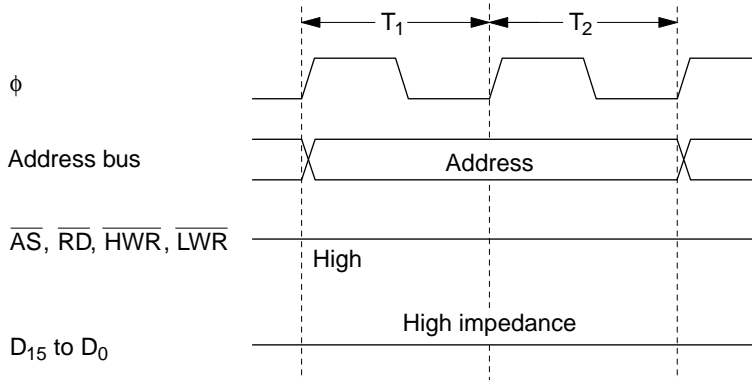


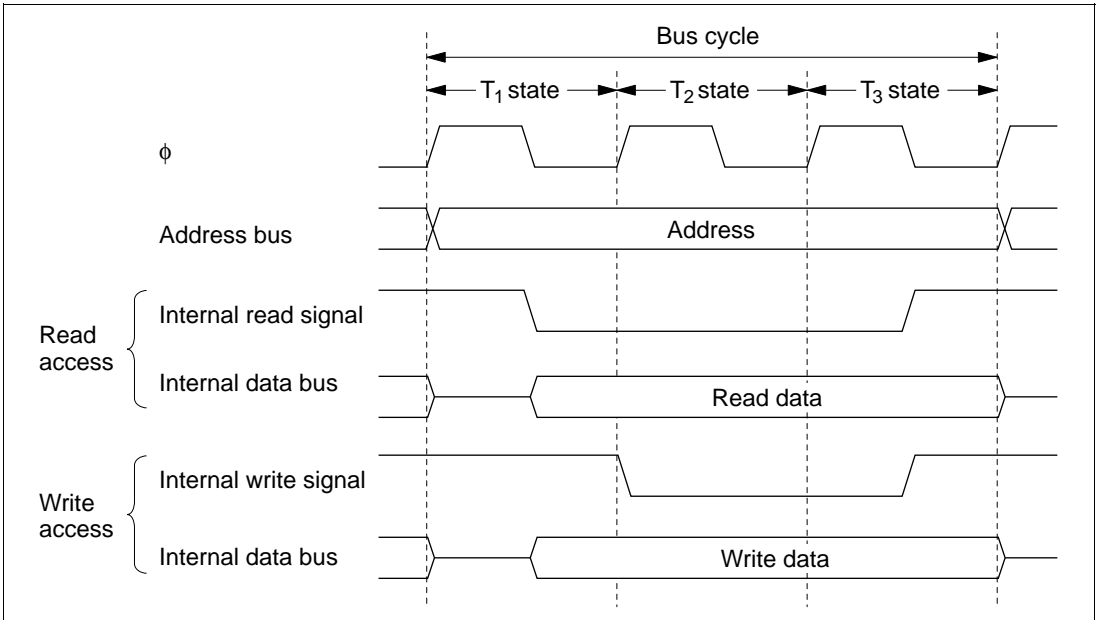
Figure 2.15 On-Chip Memory Access Cycle



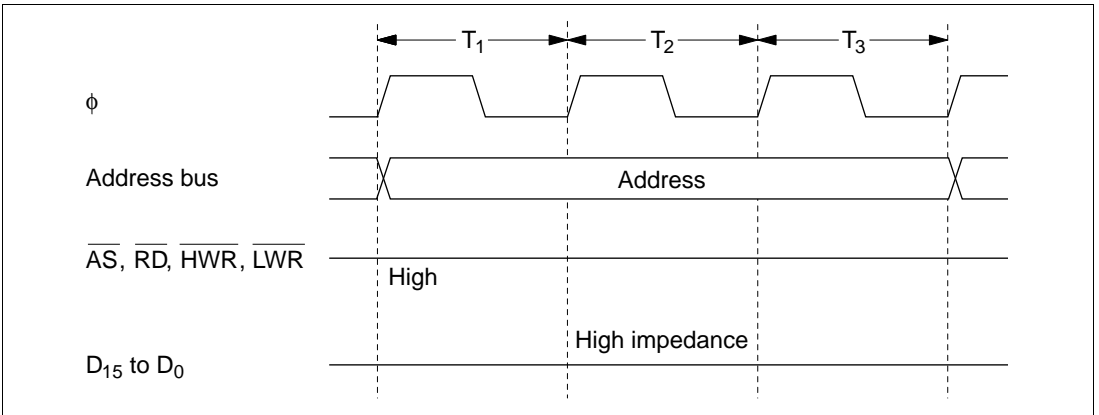
**Figure 2.16 Pin States during On-Chip Memory Access**

### 2.9.3 On-Chip Supporting Module Access Timing

The on-chip supporting modules are accessed in three states. The data bus is 8 or 16 bits wide, depending on the internal I/O register being accessed. Figure 2.17 shows the on-chip supporting module access timing. Figure 2.18 indicates the pin states.



**Figure 2.17 Access Cycle for On-Chip Supporting Modules**



**Figure 2.18 Pin States during Access to On-Chip Supporting Modules**

### 2.9.4 Access to External Address Space

The external address space is divided into eight areas (areas 0 to 7). Bus-controller settings determine whether each area is accessed via an 8-bit or 16-bit bus, and whether it is accessed in two or three states. For details see section 6, Bus Controller.



# Section 3 MCU Operating Modes

## 3.1 Overview

### 3.1.1 Operating Mode Selection

The H8/3067 Series has seven operating modes (modes 1 to 7) that are selected by the mode pins (MD<sub>2</sub> to MD<sub>0</sub>) as indicated in table 3.1. The input at these pins determines the size of the address space and the initial bus mode.

**Table 3.1 Operating Mode Selection**

Operating Mode	Mode Pins			Description			
	MD <sub>2</sub>	MD <sub>1</sub>	MD <sub>0</sub>	Address Space	Initial Bus Mode* <sup>1</sup>	On-Chip ROM	On-Chip RAM
—	0	0	0	—	—	—	—
Mode 1	0	0	1	Expanded mode	8 bits	Disabled	Enabled* <sup>2</sup>
Mode 2	0	1	0	Expanded mode	16 bits	Disabled	Enabled* <sup>2</sup>
Mode 3	0	1	1	Expanded mode	8 bits	Disabled	Enabled* <sup>2</sup>
Mode 4	1	0	0	Expanded mode	16 bits	Disabled	Enabled* <sup>2</sup>
Mode 5	1	0	1	Expanded mode	8 bits	Enabled	Enabled* <sup>2</sup>
Mode 6	1	1	0	Single-chip normal mode	—	Enabled	Enabled
Mode 7	1	1	1	Single-chip advanced mode	—	Enabled	Enabled

- Notes: 1. In modes 1 to 5, an 8-bit or 16-bit data bus can be selected on a per-area basis by settings made in the area bus width control register (ABWCR). For details see section 6, Bus Controller.
2. If the RAME bit in SYSCR is cleared to 0, these addresses become external addresses.

For the address space size there are three choices: 64 kbytes, 1 Mbyte, or 16 Mbyte. The external data bus is either 8 or 16 bits wide depending on ABWCR settings. If 8-bit access is selected for all areas, 8-bit bus mode is used. For details see section 6, Bus Controller.

Modes 1 to 4 are externally expanded modes that enable access to external memory and peripheral devices and disable access to the on-chip ROM. Modes 1 and 2 support a maximum address space of 1 Mbyte. Modes 3 and 4 support a maximum address space of 16 Mbytes.

Mode 5 is an externally expanded mode that enables access to external memory and peripheral devices and also enables access to the on-chip ROM. Mode 5 supports a maximum address space of 16 Mbytes.

Modes 6 and 7 are single-chip modes that operate using the on-chip ROM, RAM, and registers, and makes all I/O ports available. Mode 6 supports a maximum address space of 64 kbytes. Mode 7 supports a maximum address space of 1 Mbyte.

The H8/3067 Series can be used only in modes 1 to 7. The inputs at the mode pins must select one of these seven modes. The inputs at the mode pins must not be changed during operation.

### 3.1.2 Register Configuration

The H8/3067 Series has a mode control register (MDCR) that indicates the inputs at the mode pins (MD<sub>2</sub> to MD<sub>0</sub>), and a system control register (SYSCR). Table 3.2 summarizes these registers.

**Table 3.2 Registers**

Address*	Name	Abbreviation	R/W	Initial Value
H'EE011	Mode control register	MDCR	R	Undetermined
H'EE012	System control register	SYSCR	R/W	H'09

Note: \* Lower 20 bits of the address in advanced mode.

## 3.2 Mode Control Register (MDCR)

MDCR is an 8-bit read-only register that indicates the current operating mode of the H8/3067 Series.

Bit	7	6	5	4	3	2	1	0
	—	—	—	—	—	MDS2	MDS1	MDS0
Initial value	1	1	0	0	0	—*	—*	—*
Read/Write	—	—	—	—	—	R	R	R

**Reserved bits**
**Reserved bits**
**Mode select 2 to 0**  
Bits indicating the current operating mode

Note: \* Determined by pins MD<sub>2</sub> to MD<sub>0</sub>.

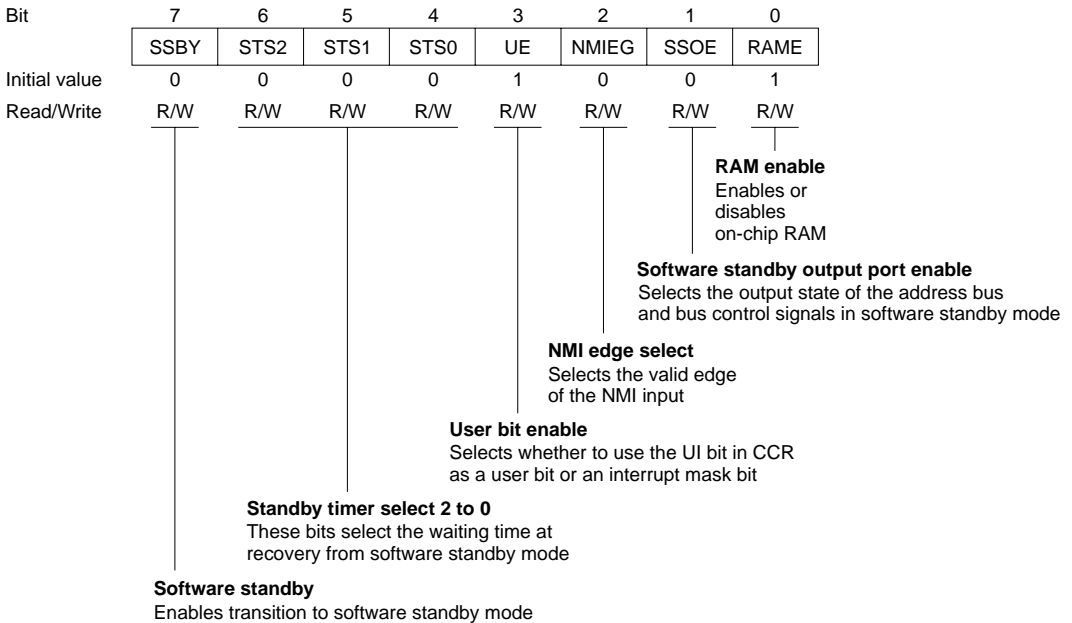
**Bits 7 and 6—Reserved:** These bits can not be modified and are always read as 1.

**Bits 5 to 3—Reserved:** These bits can not be modified and are always read as 0.

**Bits 2 to 0—Mode Select 2 to 0 (MDS2 to MDS0):** These bits indicate the logic levels at pins MD<sub>2</sub> to MD<sub>0</sub> (the current operating mode). MDS2 to MDS0 correspond to MD<sub>2</sub> to MD<sub>0</sub>. MDS2 to MDS0 are read-only bits. The mode pin (MD<sub>2</sub> to MD<sub>0</sub>) levels are latched into these bits when MDCR is read.

### 3.3 System Control Register (SYSCR)

SYSCR is an 8-bit register that controls the operation of the H8/3067 Series.



**Bit 7—Software Standby (SSBY):** Enables transition to software standby mode. (For further information about software standby mode see section 20, Power-Down State.)

When software standby mode is exited by an external interrupt, this bit remains set to 1. To clear this bit, write 0.

#### Bit 7

SSBY	Description	
0	SLEEP instruction causes transition to sleep mode	(Initial value)
1	SLEEP instruction causes transition to software standby mode	

**Bits 6 to 4—Standby Timer Select 2 to 0 (STS2 to STS0):** These bits select the length of time the CPU and on-chip supporting modules wait for the internal clock oscillator to settle when software standby mode is exited by an external interrupt.

When using a crystal oscillator, set these bits so that the waiting time will be at least 7 ms at the system clock rate.

For further information about waiting time selection, see section 20.4.3, Selection of Waiting Time for Exit from Software Standby Mode.

Bit 6 STS2	Bit 5 STS1	Bit 4 STS0	Description
0	0	0	Waiting time = 8,192 states (Initial value)
0	0	1	Waiting time = 16,384 states
0	1	0	Waiting time = 32,768 states
0	1	1	Waiting time = 65,536 states
1	0	0	Waiting time = 131,072 states
1	0	1	Waiting time = 262,144 states
1	1	0	Waiting time = 1,024 states
1	1	1	Illegal setting

**Bit 3—User Bit Enable (UE):** Selects whether to use the UI bit in the condition code register as a user bit or an interrupt mask bit.

Bit 3 UE	Description
0	UI bit in CCR is used as an interrupt mask bit
1	UI bit in CCR is used as a user bit (Initial value)

**Bit 2—NMI Edge Select (NMIEG):** Selects the valid edge of the NMI input.

Bit 2 NMIEG	Description
0	An interrupt is requested at the falling edge of NMI (Initial value)
1	An interrupt is requested at the rising edge of NMI

**Bit 1—Software Standby Output Port Enable (SSOE):** Specifies whether the address bus and bus control signals ( $\overline{CS}_0$  to  $\overline{CS}_7$ ,  $\overline{AS}$ ,  $\overline{RD}$ ,  $\overline{HWR}$ ,  $\overline{LWR}$ ,  $\overline{UCAS}$ ,  $\overline{LCAS}$ , and  $\overline{RFSH}$ ) are kept as outputs or fixed high, or placed in the high-impedance state in software standby mode.

**Bit 1**

SSOE	Description
0	In software standby mode, the address bus and bus control signals are all high-impedance (Initial value)
1	In software standby mode, the address bus retains its output state and bus control signals are fixed high

**Bit 0—RAM Enable (RAME):** Enables or disables the on-chip RAM. The RAME bit is initialized by the rising edge of the  $\overline{RES}$  signal. It is not initialized in software standby mode.

**Bit 0**

RAME	Description
0	On-chip RAM is disabled
1	On-chip RAM is enabled (Initial value)

## 3.4 Operating Mode Descriptions

### 3.4.1 Mode 1

Ports 1, 2, and 5 function as address pins  $A_{19}$  to  $A_0$ , permitting access to a maximum 1-Mbyte address space. The initial bus mode after a reset is 8 bits, with 8-bit access to all areas. If at least one area is designated for 16-bit access in ABWCR, the bus mode switches to 16 bits.

### 3.4.2 Mode 2

Ports 1, 2, and 5 function as address pins  $A_{19}$  to  $A_0$ , permitting access to a maximum 1-Mbyte address space. The initial bus mode after a reset is 16 bits, with 16-bit access to all areas. If all areas are designated for 8-bit access in ABWCR, the bus mode switches to 8 bits.

### 3.4.3 Mode 3

Ports 1, 2, and 5 and part of port A function as address pins  $A_{23}$  to  $A_0$ , permitting access to a maximum 16-Mbyte address space. The initial bus mode after a reset is 8 bits, with 8-bit access to all areas. If at least one area is designated for 16-bit access in ABWCR, the bus mode switches to 16 bits.  $A_{23}$  to  $A_{21}$  are valid when 0 is written in bits 7 to 5 of the bus release control register (BRCR). (In this mode  $A_{20}$  is always used for address output.)

### 3.4.4 Mode 4

Ports 1, 2, and 5 and part of port A function as address pins  $A_{23}$  to  $A_0$ , permitting access to a maximum 16-Mbyte address space. The initial bus mode after a reset is 16 bits, with 16-bit access to all areas. If all areas are designated for 8-bit access in ABWCR, the bus mode switches to 8 bits.  $A_{23}$  to  $A_{21}$  are valid when 0 is written in bits 7 to 5 of BRCCR. (In this mode  $A_{20}$  is always used for address output.)

### 3.4.5 Mode 5

Ports 1, 2, and 5 and part of port A can function as address pins  $A_{23}$  to  $A_0$ , permitting access to a maximum 16-Mbyte address space, but following a reset they are input ports. To use ports 1, 2, and 5 as an address bus, the corresponding bits in their data direction registers (P1DDR, P2DDR, and P5DDR) must be set to 1. For  $A_{23}$  to  $A_{20}$  output, write 0 in bits 7 to 4 of BRCCR. The initial bus mode after a reset is 8 bits, with 8-bit access to all areas. If at least one area is designated for 16-bit access in ABWCR, the bus mode switches to 16 bits.

### 3.4.6 Mode 6

This mode operates using the on-chip ROM, RAM, and registers. All I/O ports are available. Mode 6 supports a maximum address space of 64 kbytes.

### 3.4.7 Mode 7

This mode operates using the on-chip ROM, RAM, and registers. All I/O ports are available. Mode 7 supports a 1-Mbyte address space.

## 3.5 Pin Functions in Each Operating Mode

The pin functions of ports 1 to 5 and port A vary depending on the operating mode. Table 3.3 indicates their functions in each operating mode.

**Table 3.3 Pin Functions in Each Mode**

Port	Mode 1	Mode 2	Mode 3	Mode 4	Mode 5	Mode 6	Mode 7
Port 1	A <sub>7</sub> to A <sub>0</sub>	A <sub>7</sub> to A <sub>0</sub>	A <sub>7</sub> to A <sub>0</sub>	A <sub>7</sub> to A <sub>0</sub>	P1 <sub>7</sub> to P1 <sub>0</sub> <sup>*2</sup>	P1 <sub>7</sub> to P1 <sub>0</sub>	P1 <sub>7</sub> to P1 <sub>0</sub>
Port 2	A <sub>15</sub> to A <sub>8</sub>	A <sub>15</sub> to A <sub>8</sub>	A <sub>15</sub> to A <sub>8</sub>	A <sub>15</sub> to A <sub>8</sub>	P2 <sub>7</sub> to P2 <sub>0</sub> <sup>*2</sup>	P2 <sub>7</sub> to P2 <sub>0</sub>	P2 <sub>7</sub> to P2 <sub>0</sub>
Port 3	D <sub>15</sub> to D <sub>8</sub>	D <sub>15</sub> to D <sub>8</sub>	D <sub>15</sub> to D <sub>8</sub>	D <sub>15</sub> to D <sub>8</sub>	D <sub>15</sub> to D <sub>8</sub>	P3 <sub>7</sub> to P3 <sub>0</sub>	P3 <sub>7</sub> to P3 <sub>0</sub>
Port 4	P4 <sub>7</sub> to P4 <sub>0</sub> <sup>*1</sup>	D <sub>7</sub> to D <sub>0</sub> <sup>*1</sup>	P4 <sub>7</sub> to P4 <sub>0</sub> <sup>*1</sup>	D <sub>7</sub> to D <sub>0</sub> <sup>*1</sup>	P4 <sub>7</sub> to P4 <sub>0</sub> <sup>*1</sup>	P4 <sub>7</sub> to P4 <sub>0</sub>	P4 <sub>7</sub> to P4 <sub>0</sub>
Port 5	A <sub>19</sub> to A <sub>16</sub>	A <sub>19</sub> to A <sub>16</sub>	A <sub>19</sub> to A <sub>16</sub>	A <sub>19</sub> to A <sub>16</sub>	P5 <sub>3</sub> to P5 <sub>0</sub> <sup>*2</sup>	P5 <sub>3</sub> to P5 <sub>0</sub>	P5 <sub>3</sub> to P5 <sub>0</sub>
Port A	PA <sub>7</sub> to PA <sub>4</sub>	PA <sub>7</sub> to PA <sub>4</sub>	PA <sub>6</sub> to PA <sub>4</sub> , A <sub>20</sub> <sup>*3</sup>	PA <sub>6</sub> to PA <sub>4</sub> , A <sub>20</sub> <sup>*3</sup>	PA <sub>7</sub> to PA <sub>4</sub> <sup>*4</sup>	PA <sub>7</sub> to PA <sub>4</sub>	PA <sub>7</sub> to PA <sub>4</sub>

- Notes: 1. Initial state. The bus mode can be switched by settings in ABWCR. These pins function as P4<sub>7</sub> to P4<sub>0</sub> in 8-bit bus mode, and as D<sub>7</sub> to D<sub>0</sub> in 16-bit bus mode.
2. Initial state. These pins become address output pins when the corresponding bits in the data direction registers (P1DDR, P2DDR, P5DDR) are set to 1.
3. Initial state. A<sub>20</sub> is always an address output pin. PA<sub>6</sub> to PA<sub>4</sub> are switched over to A<sub>23</sub> to A<sub>21</sub> output by writing 0 in bits 7 to 5 of BRCCR.
4. Initial state. PA<sub>7</sub> to PA<sub>4</sub> are switched over to A<sub>23</sub> to A<sub>20</sub> output by writing 0 in bits 7 to 4 of BRCCR.

## 3.6 Memory Map in Each Operating Mode

Figure 3.1 to 3.3 show a memory maps of the H8/3067, H8/3066, and H8/3065. The address space is divided into eight areas.

The initial bus mode differs between modes 1 and 2, and also between modes 3 and 4.

The address locations of the on-chip RAM and on-chip registers differ between the 64-kbyte mode (mode 6), the 1-Mbyte modes (modes 1, 2, and 7), and the 16-Mbyte modes (modes 3, 4, and 5). The address range specifiable by the CPU in the 8- and 16-bit absolute addressing modes (@aa:8 and @aa:16) also differs.

### 3.6.1 Note on Reserved Areas

The H8/3067 Series memory map includes reserved areas to which read/write access is prohibited. Note that normal operation is not guaranteed if the following reserved areas are accessed.

(1) The reserved area in the internal I/O register space

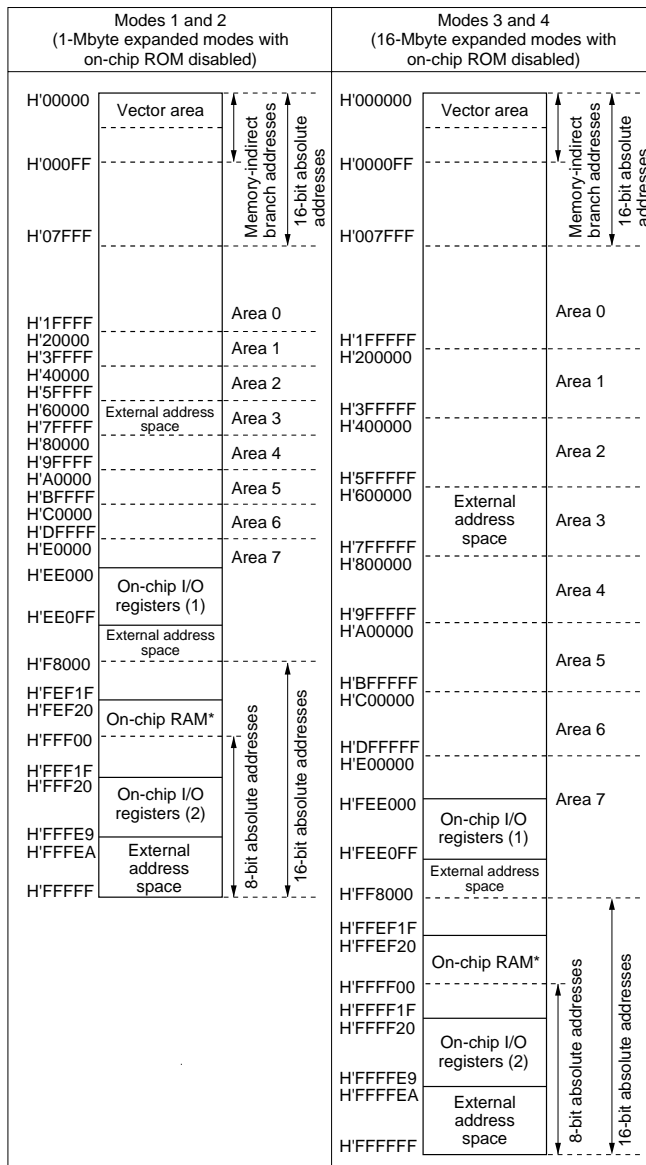
The H8/3067 Series internal I/O register space includes a reserved area to which access is prohibited. For details see Appendix B, Internal I/O Registers.



(2) Other reserved areas

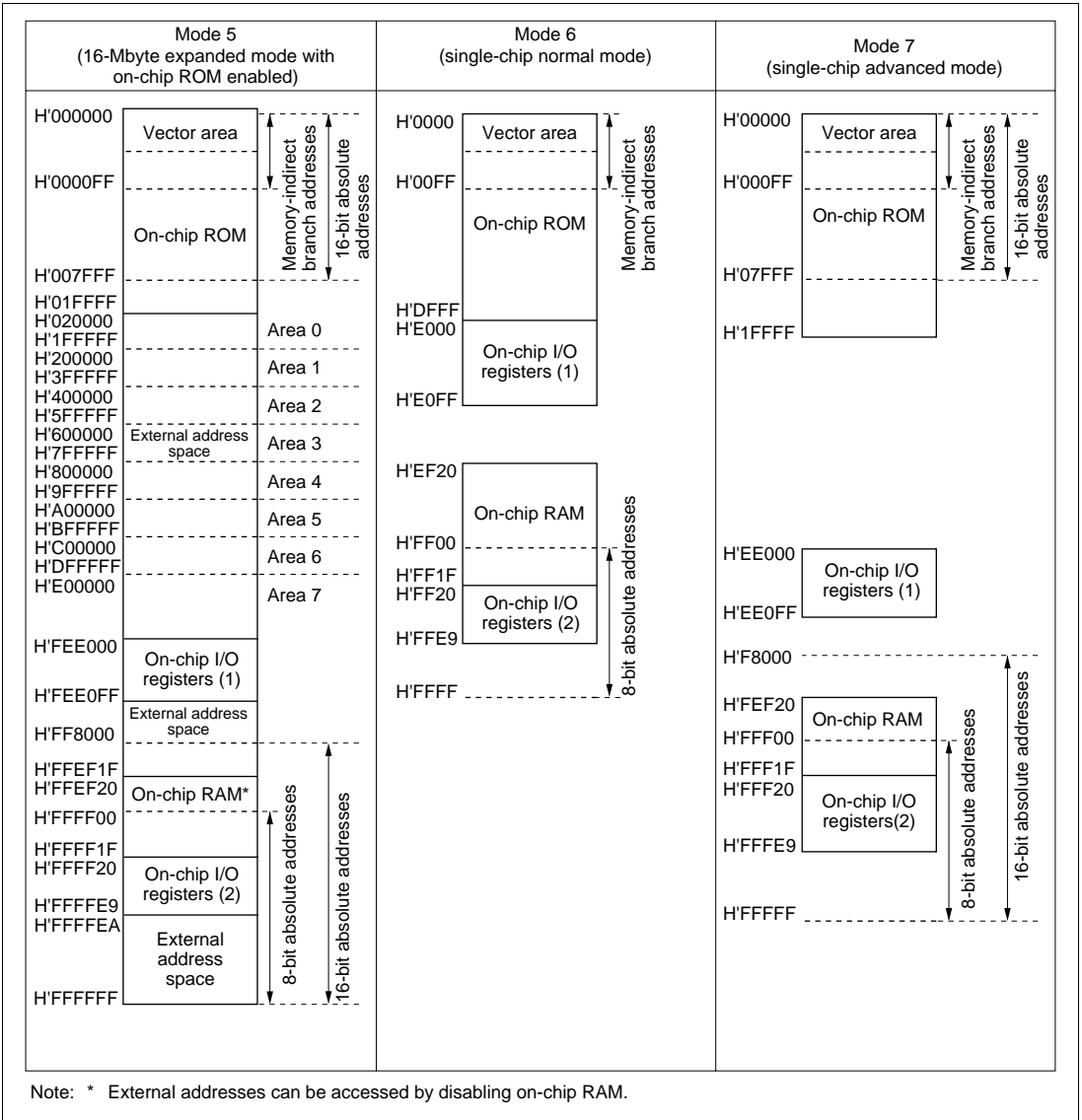
In mode 5 in the H8/3066 and H8/3065, there is a reserved area in area 0 as shown in figures 3.2 and 3.3.

In modes 1 to 5 in the H8/3065, there is a reserved area in area 7 as shown in figure 3.3.

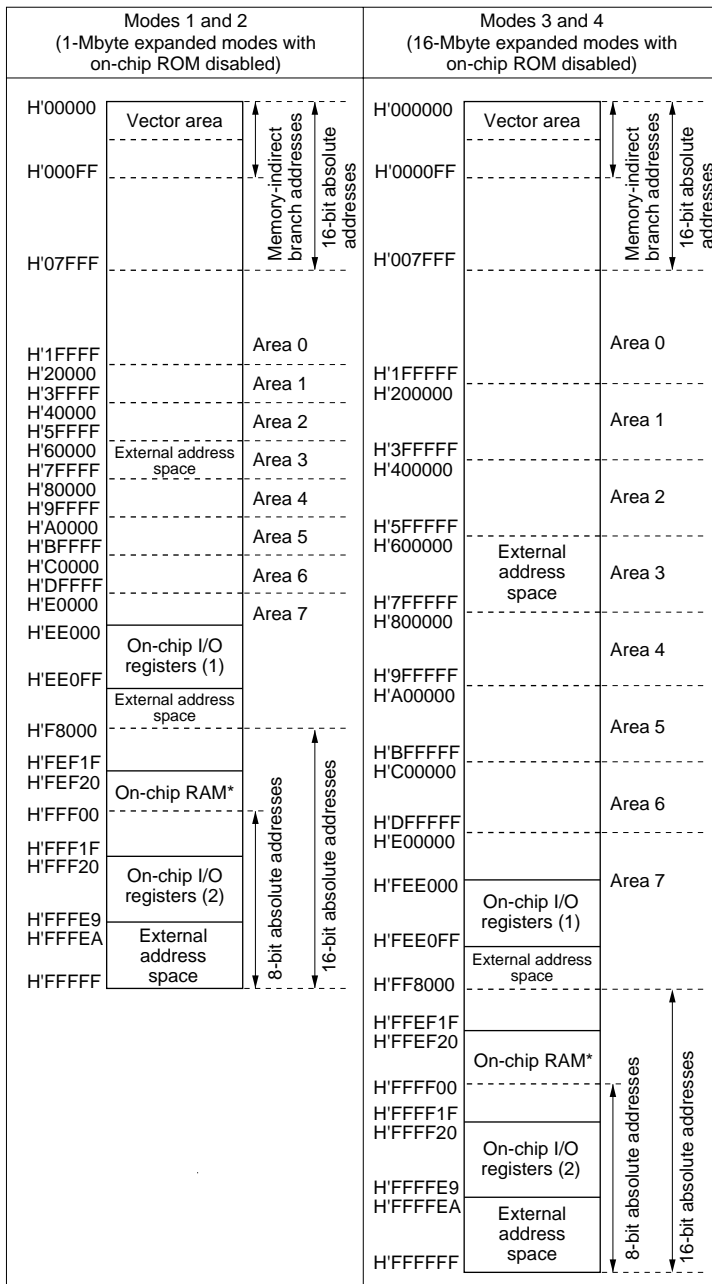


Note: \* External addresses can be accessed by disabling on-chip RAM.

Figure 3.1 H8/3067 Memory Map in Each Operating Mode (1)

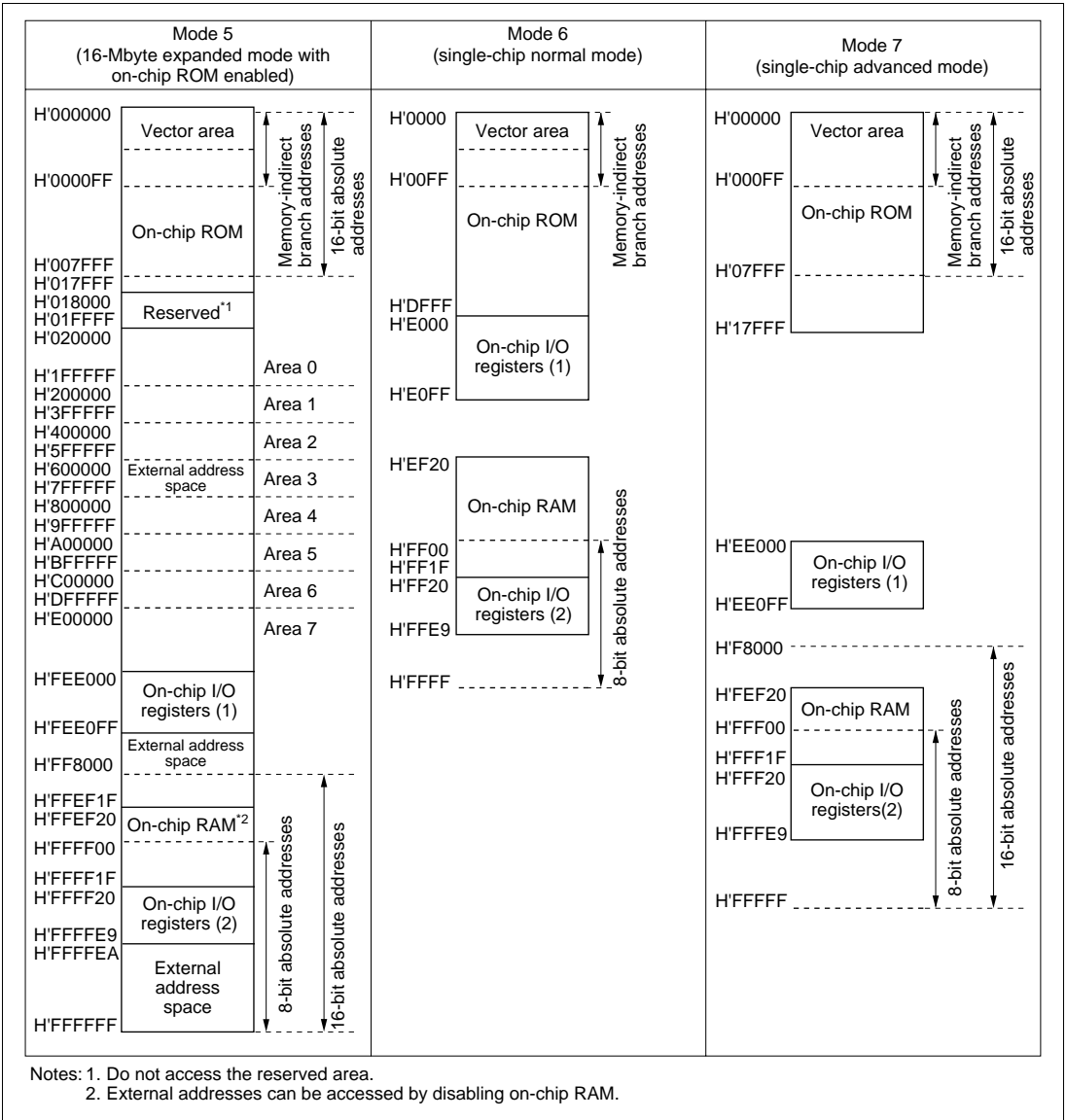


**Figure 3.1 H8/3067 Memory Map in Each Operating Mode (2)**

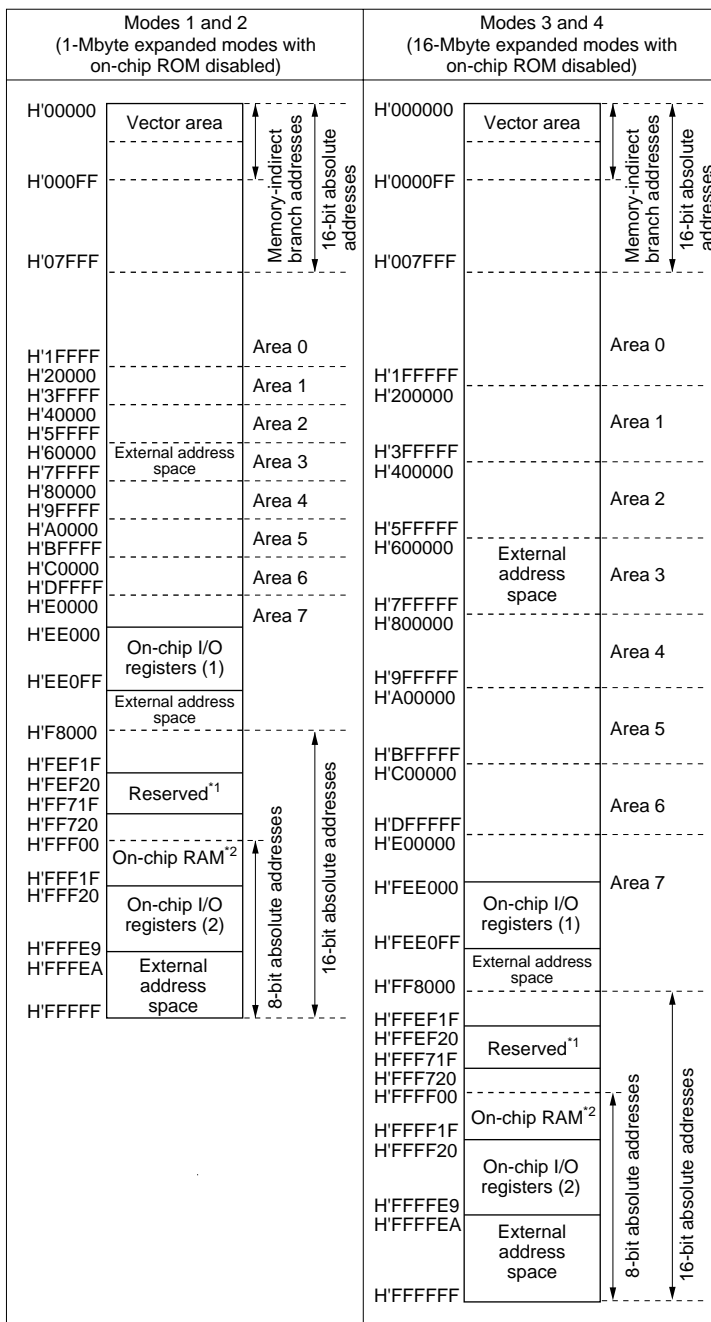


Note: \* External addresses can be accessed by disabling on-chip RAM.

Figure 3.2 H8/3066 Memory Map in Each Operating Mode (1)



**Figure 3.2 H8/3066 Memory Map in Each Operating Mode (2)**



Notes: 1. Do not access the reserved area.

2. External addresses can be accessed by disabling on-chip RAM.

Figure 3.3 H8/3065 Memory Map in Each Operating Mode (1)

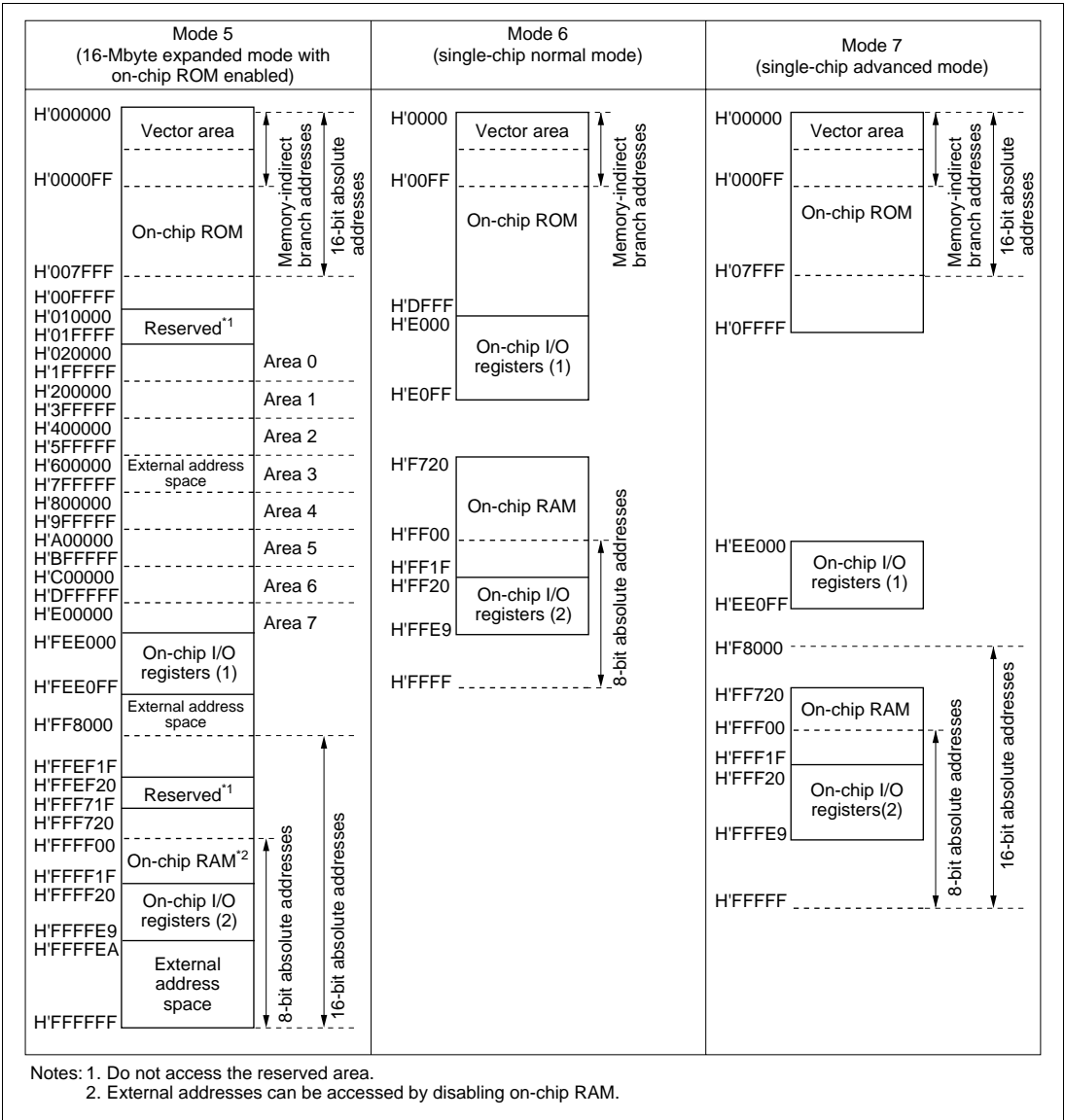


Figure 3.3 H8/3065 Memory Map in Each Operating Mode (2)

# Section 4 Exception Handling

## 4.1 Overview

### 4.1.1 Exception Handling Types and Priority

As table 4.1 indicates, exception handling may be caused by a reset, trap instruction, or interrupt. Exception handling is prioritized as shown in table 4.1. If two or more exceptions occur simultaneously, they are accepted and processed in priority order. Trap instruction exceptions are accepted at all times in the program execution state.

**Table 4.1 Exception Types and Priority**

Priority	Exception Type	Start of Exception Handling
High	Reset	Starts immediately after a low-to-high transition at the $\overline{\text{RES}}$ pin
↑	Interrupt	Interrupt requests are handled when execution of the current instruction or handling of the current exception is completed
	Trap instruction (TRAPA)	Started by execution of a trap instruction (TRAPA)
Low		

### 4.1.2 Exception Handling Operation

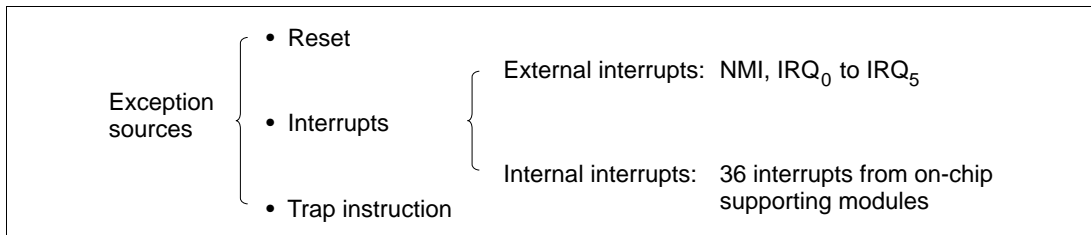
Exceptions originate from various sources. Trap instructions and interrupts are handled as follows.

1. The program counter (PC) and condition code register (CCR) are pushed onto the stack.
2. The CCR interrupt mask bit is set to 1.
3. A vector address corresponding to the exception source is generated, and program execution starts from that address.

For a reset exception, steps 2 and 3 above are carried out.

### 4.1.3 Exception Vector Table

The exception sources are classified as shown in figure 4.1. Different vectors are assigned to different exception sources. Table 4.2 lists the exception sources and their vector addresses.



**Figure 4.1 Exception Sources**



**Table 4.2 Exception Vector Table**

Exception Source	Vector Number	Vector Address*1	
		Advanced Mode	Normal Mode
Reset	0	H'0000 to H'0003	H'0000 to H'0001
Reserved for system use	1	H'0004 to H'0007	H'0002 to H'0003
	2	H'0008 to H'000B	H'0004 to H'0005
	3	H'000C to H'000F	H'0006 to H'0007
	4	H'0010 to H'0013	H'0008 to H'0009
	5	H'0014 to H'0017	H'000A to H'000B
	6	H'0018 to H'001B	H'000C to H'000D
	External interrupt (NMI)	7	H'001C to H'001F
Trap instruction (4 sources)	8	H'0020 to H'0023	H'0010 to H'0011
	9	H'0024 to H'0027	H'0012 to H'0013
	10	H'0028 to H'002B	H'0014 to H'0015
	11	H'002C to H'002F	H'0016 to H'0017
External interrupt IRQ <sub>0</sub>	12	H'0030 to H'0033	H'0018 to H'0019
External interrupt IRQ <sub>1</sub>	13	H'0034 to H'0037	H'001A to H'001B
External interrupt IRQ <sub>2</sub>	14	H'0038 to H'003B	H'001C to H'001D
External interrupt IRQ <sub>3</sub>	15	H'003C to H'003F	H'001E to H'001F
External interrupt IRQ <sub>4</sub>	16	H'0040 to H'0043	H'0020 to H'0021
External interrupt IRQ <sub>5</sub>	17	H'0044 to H'0047	H'0022 to H'0023
Reserved for system use	18	H'0048 to H'004B	H'0024 to H'0025
	19	H'004C to H'004F	H'0026 to H'0027
Internal interrupts*2	20	H'0050 to H'0053	H'0028 to H'0029
	to	to	to
	63	H'00FC to H'00FF	H'007E to H'007F

Notes: 1. Lower 16 bits of the address.

2. For the internal interrupt vectors, see section 5.3.3, Interrupt Vector Table.

## 4.2 Reset

### 4.2.1 Overview

A reset is the highest-priority exception. When the  $\overline{\text{RES}}$  pin goes low, all processing halts and the chip enters the reset state. A reset initializes the internal state of the CPU and the registers of the on-chip supporting modules. Reset exception handling begins when the  $\overline{\text{RES}}$  pin changes from low to high.

The chip can also be reset by overflow of the watchdog timer. For details see section 12, Watchdog Timer.

### 4.2.2 Reset Sequence

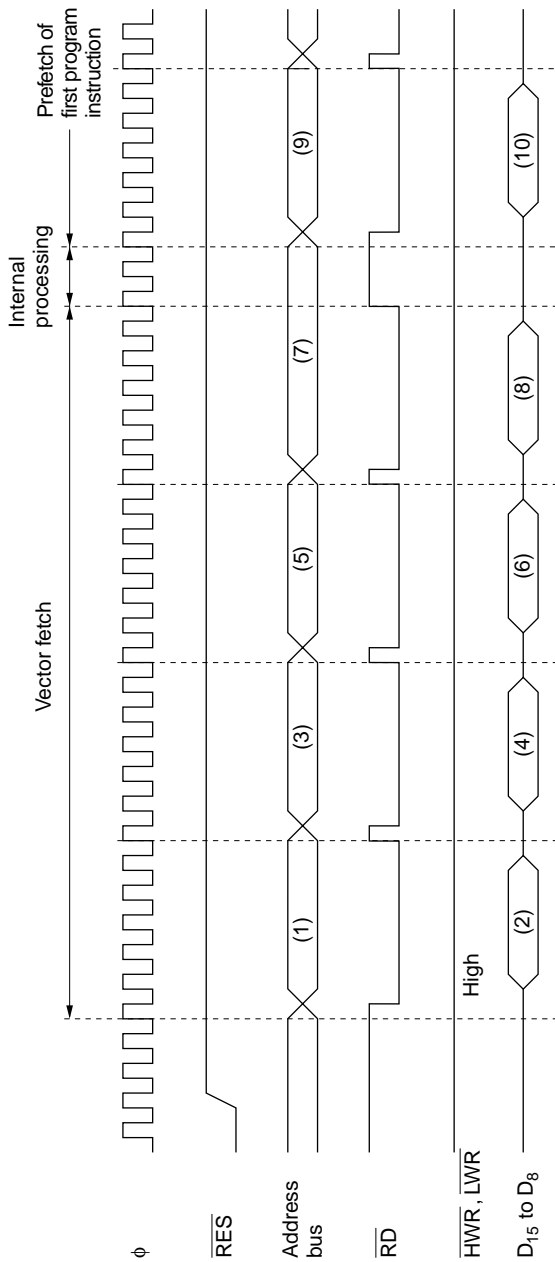
The chip enters the reset state when the  $\overline{\text{RES}}$  pin goes low.

To ensure that the chip is reset, hold the  $\overline{\text{RES}}$  pin low for at least 20 ms at power-up. To reset the chip during operation, hold the  $\overline{\text{RES}}$  pin low for at least 10 system clock ( $\phi$ ) cycles. When the flash memory and flash memory R versions are used, the  $\overline{\text{RES}}$  pin must be held low for at least 20 system clock cycles. See appendix D.2, Pin States at Reset, for the states of the pins in the reset state.

When the  $\overline{\text{RES}}$  pin goes high after being held low for the necessary time, the chip starts reset exception handling as follows.

- The internal state of the CPU and the registers of the on-chip supporting modules are initialized, and the I bit is set to 1 in CCR.
- The contents of the reset vector address (H'0000 to H'0003 in advanced mode, H'0000 to H'0001 in normal mode) are read, and program execution starts from the address indicated in the vector address.

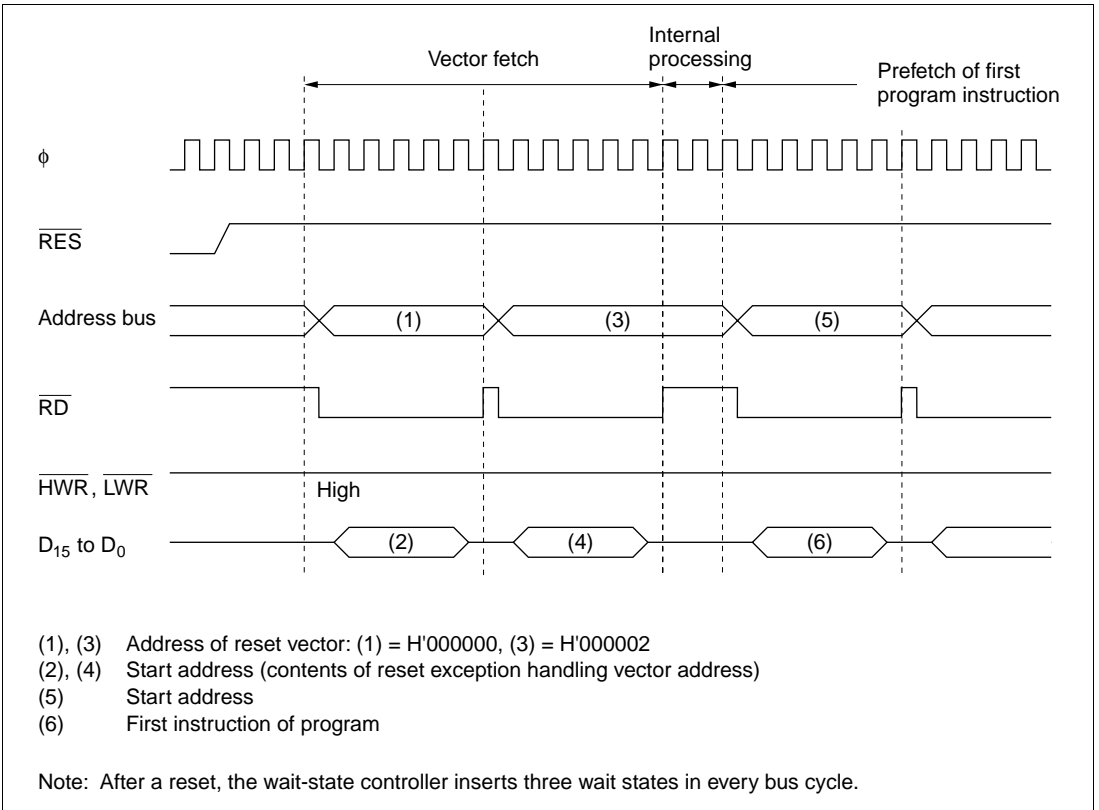
Figure 4.2 shows the reset sequence in modes 1 and 3. Figure 4.3 shows the reset sequence in modes 2 and 4. Figure 4.4 shows the reset sequence in mode 6.



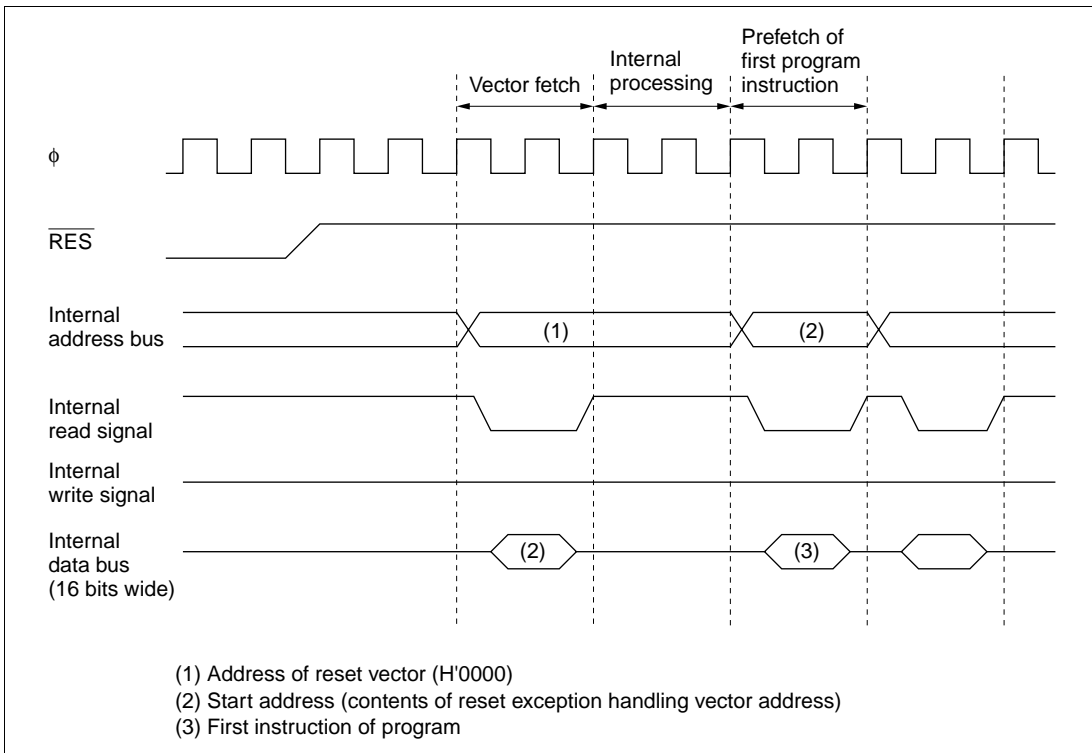
- (1), (3), (5), (7) Address of reset vector: (1) = H'000000, (3) = H'000001, (5) = H'000002, (7) = H'000003  
 (2), (4), (6), (8) Start address (contents of reset exception handling vector address)  
 (9) Start address  
 (10) First instruction of program

Note: After a reset, the wait-state controller inserts three wait states in every bus cycle.

Figure 4.2 Reset Sequence (Modes 1 and 3)



**Figure 4.3 Reset Sequence (Modes 2 and 4)**



**Figure 4.4 Reset Sequence (Mode 6)**

### 4.2.3 Interrupts after Reset

If an interrupt is accepted after a reset but before the stack pointer (SP) is initialized, PC and CCR will not be saved correctly, leading to a program crash. To prevent this, all interrupt requests, including NMI, are disabled immediately after a reset. The first instruction of the program is always executed immediately after the reset state ends. This instruction should initialize the stack pointer (example: `MOV.L #xx:32, SP`).

## 4.3 Interrupts

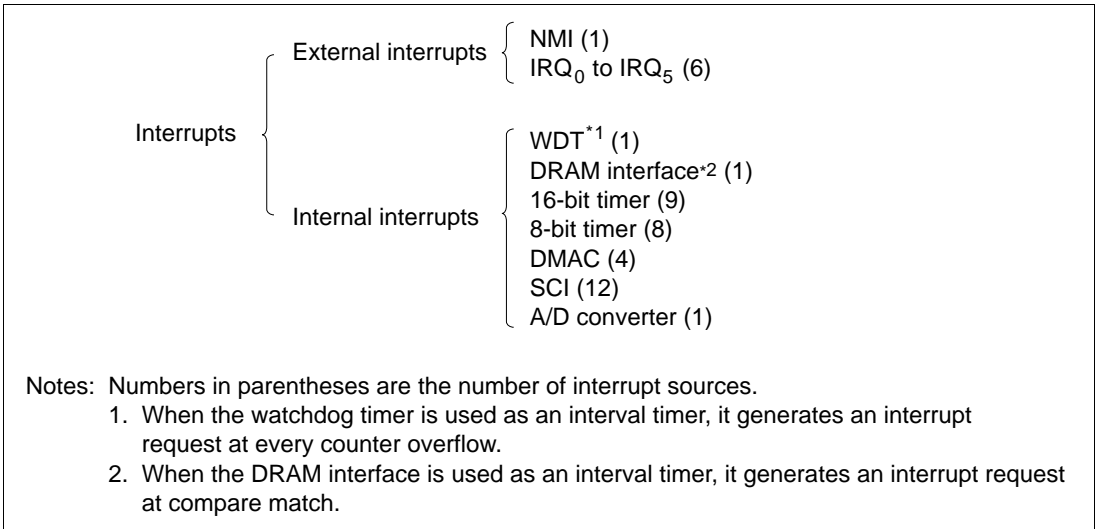
Interrupt exception handling can be requested by seven external sources (NMI, IRQ<sub>0</sub> to IRQ<sub>5</sub>), and 36 internal sources in the on-chip supporting modules. Figure 4.5 classifies the interrupt sources and indicates the number of interrupts of each type.

The on-chip supporting modules that can request interrupts are the watchdog timer (WDT), DRAM interface, 16-bit timer, 8-bit timer, DMA controller (DMAC), serial communication interface (SCI), and A/D converter. Each interrupt source has a separate vector address.

NMI is the highest-priority interrupt and is always accepted\*. Interrupts are controlled by the interrupt controller. The interrupt controller can assign interrupts other than NMI to two priority levels, and arbitrate between simultaneous interrupts. Interrupt priorities are assigned in interrupt priority registers A and B (IPRA and IPRB) in the interrupt controller.

Note: In the flash memory and flash memory R versions, NMI input is sometimes disabled. For details see 18.6.4, NMI Input Disable Conditions.

For details on interrupts see section 5, Interrupt Controller.



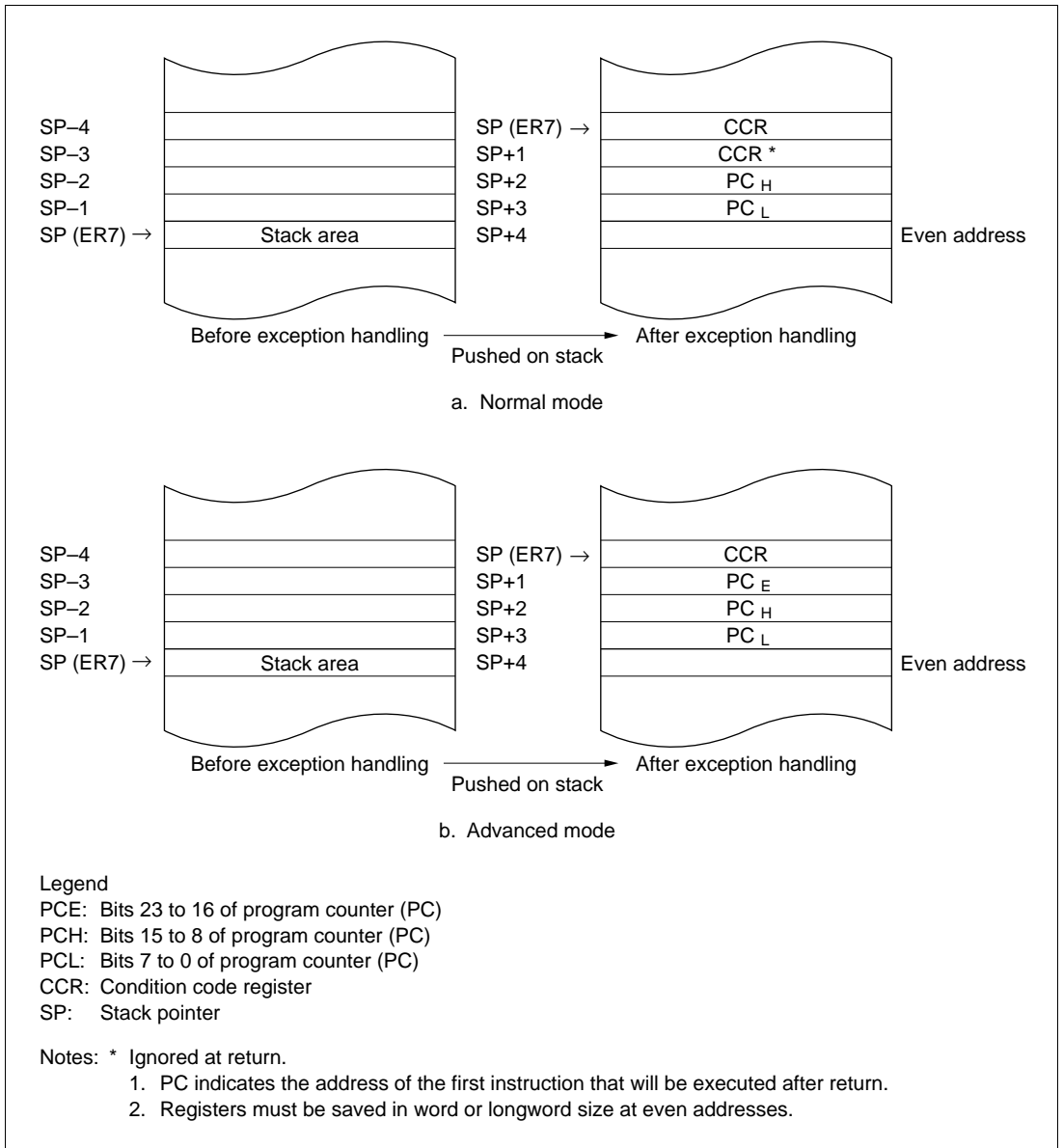
**Figure 4.5 Interrupt Sources and Number of Interrupts**

## 4.4 Trap Instruction

Trap instruction exception handling starts when a TRAPA instruction is executed. If the UE bit is set to 1 in the system control register (SYSCR), the exception handling sequence sets the I bit to 1 in CCR. If the UE bit is 0, the I and UI bits are both set to 1. The TRAPA instruction fetches a start address from a vector table entry corresponding to a vector number from 0 to 3, which is specified in the instruction code.

## 4.5 Stack Status after Exception Handling

Figure 4.6 shows the stack after completion of trap instruction exception handling and interrupt exception handling.



**Figure 4.6 Stack after Completion of Exception Handling**



## 4.6 Notes on Stack Usage

When accessing word data or longword data, the H8/3067 Series regards the lowest address bit as 0. The stack should always be accessed by word access or longword access, and the value of the stack pointer (SP, ER7) should always be kept even.

Use the following instructions to save registers:

PUSH.W Rn (or MOV.W Rn, @-SP)

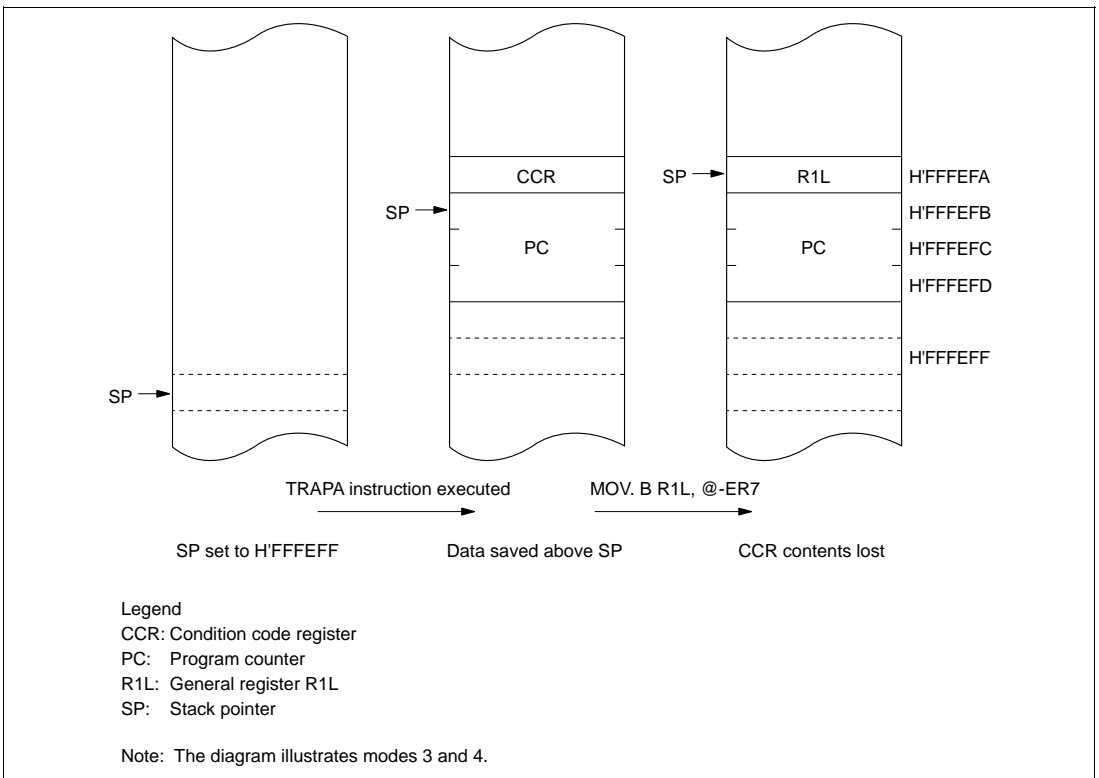
PUSH.L ERn (or MOV.L ERn, @-SP)

Use the following instructions to restore registers:

POP.W Rn (or MOV.W @SP+, Rn)

POP.L ERn (or MOV.L @SP+, ERn)

Setting SP to an odd value may lead to a malfunction. Figure 4.7 shows an example of what happens when the SP value is odd.



**Figure 4.7 Operation when SP Value is Odd**



# Section 5 Interrupt Controller

## 5.1 Overview

### 5.1.1 Features

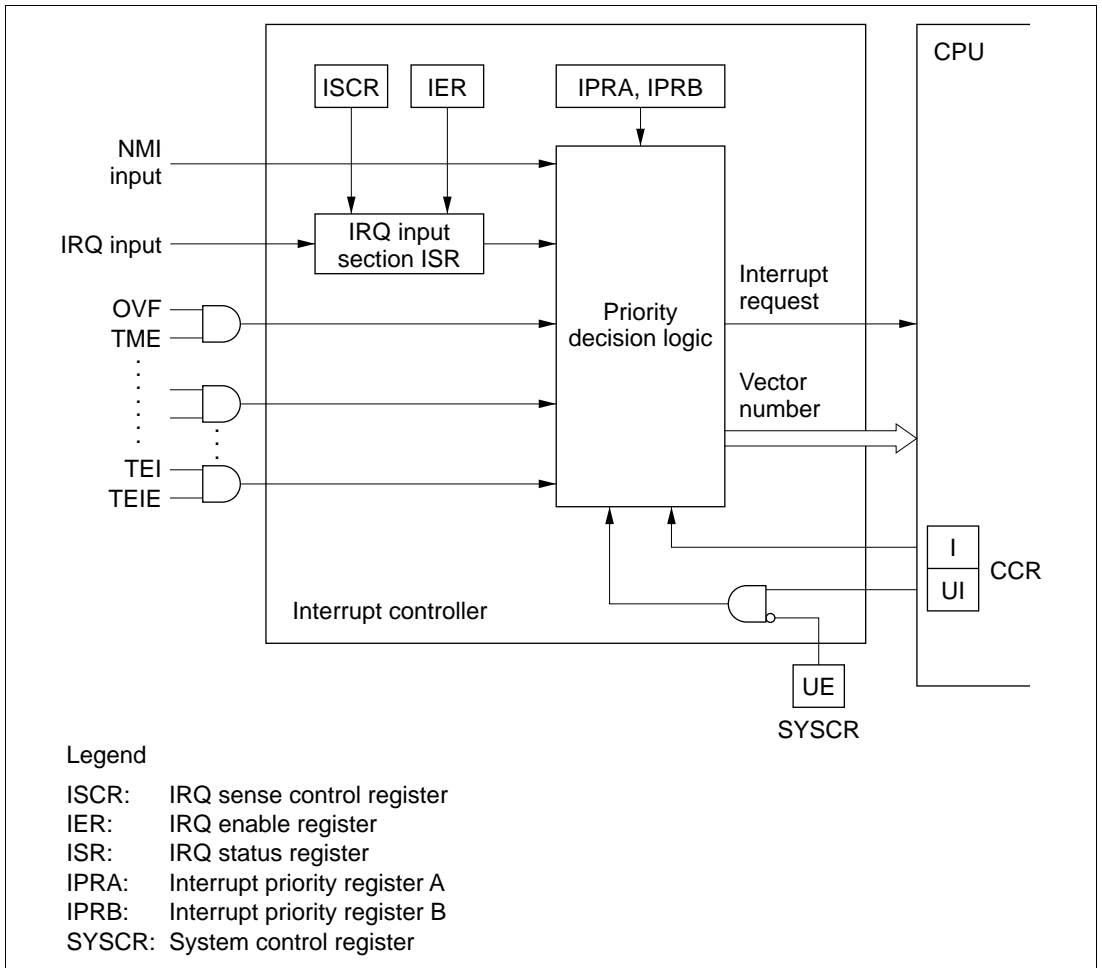
The interrupt controller has the following features:

- Interrupt priority registers (IPRs) for setting interrupt priorities  
Interrupts other than NMI can be assigned to two priority levels on a module-by-module basis in interrupt priority registers A and B (IPRA and IPRB).
- Three-level masking by the I and UI bits in the CPU condition code register (CCR)
- Seven external interrupt pins  
NMI has the highest priority and is always accepted\*; either the rising or falling edge can be selected. For each of IRQ<sub>0</sub> to IRQ<sub>5</sub>, sensing of the falling edge or level sensing can be selected independently.

Note: In the flash memory and flash memory R versions, NMI input is sometimes disabled. For details see 18.6.4, NMI Input Disable Conditions.

## 5.1.2 Block Diagram

Figure 5.1 shows a block diagram of the interrupt controller.



**Figure 5.1 Interrupt Controller Block Diagram**

### 5.1.3 Pin Configuration

Table 5.1 lists the interrupt pins.

**Table 5.1 Interrupt Pins**

Name	Abbreviation	I/O	Function
Nonmaskable interrupt	NMI	Input	Nonmaskable interrupt*, rising edge or falling edge selectable
External interrupt request 5 to 0	$\overline{\text{IRQ}}_5$ to $\overline{\text{IRQ}}_0$	Input	Maskable interrupts, falling edge or level sensing selectable

Note: In the flash memory and flash memory R versions, NMI input is sometimes disabled. For details see 18.6.4, NMI Input Disable Conditions.

### 5.1.4 Register Configuration

Table 5.2 lists the registers of the interrupt controller.

**Table 5.2 Interrupt Controller Registers**

Address* <sup>1</sup>	Name	Abbreviation	R/W	Initial Value
H'EE012	System control register	SYSCR	R/W	H'09
H'EE014	IRQ sense control register	ISCR	R/W	H'00
H'EE015	IRQ enable register	IER	R/W	H'00
H'EE016	IRQ status register	ISR	R/(W)* <sup>2</sup>	H'00
H'EE018	Interrupt priority register A	IPRA	R/W	H'00
H'EE019	Interrupt priority register B	IPRB	R/W	H'00

Notes: 1. Lower 20 bits of the address in advanced mode.  
2. Only 0 can be written, to clear flags.

## 5.2 Register Descriptions

### 5.2.1 System Control Register (SYSCR)

SYSCR is an 8-bit readable/writable register that controls software standby mode, selects the action of the UI bit in CCR, selects the NMI edge, and enables or disables the on-chip RAM.

Only bits 3 and 2 are described here. For the other bits, see section 3.3, System Control Register (SYSCR).

SYSCR is initialized to H'09 by a reset and in hardware standby mode. It is not initialized in software standby mode.

Bit	7	6	5	4	3	2	1	0
	SSBY	STS2	STS1	STS0	UE	NMIEG	SSOE	RAME
Initial value	0	0	0	0	1	0	0	1
Read/Write	R/W	R/W	R/W	R/W	R/W	R/W	R/W	R/W

**Software standby**

**Standby timer  
select 2 to 0**

**User bit enable**  
Selects whether to use the UI bit in  
CCR as a user bit or interrupt mask bit

**NMI edge select**  
Selects the NMI input edge

**Software standby  
output port enable**

**RAM enable**

**Bit 3—User Bit Enable (UE):** Selects whether to use the UI bit in CCR as a user bit or an interrupt mask bit.

**Bit 3**

<b>UE</b>	<b>Description</b>	
0	UI bit in CCR is used as interrupt mask bit	
1	UI bit in CCR is used as user bit	(Initial value)

**Bit 2—NMI Edge Select (NMIEG):** Selects the NMI input edge.

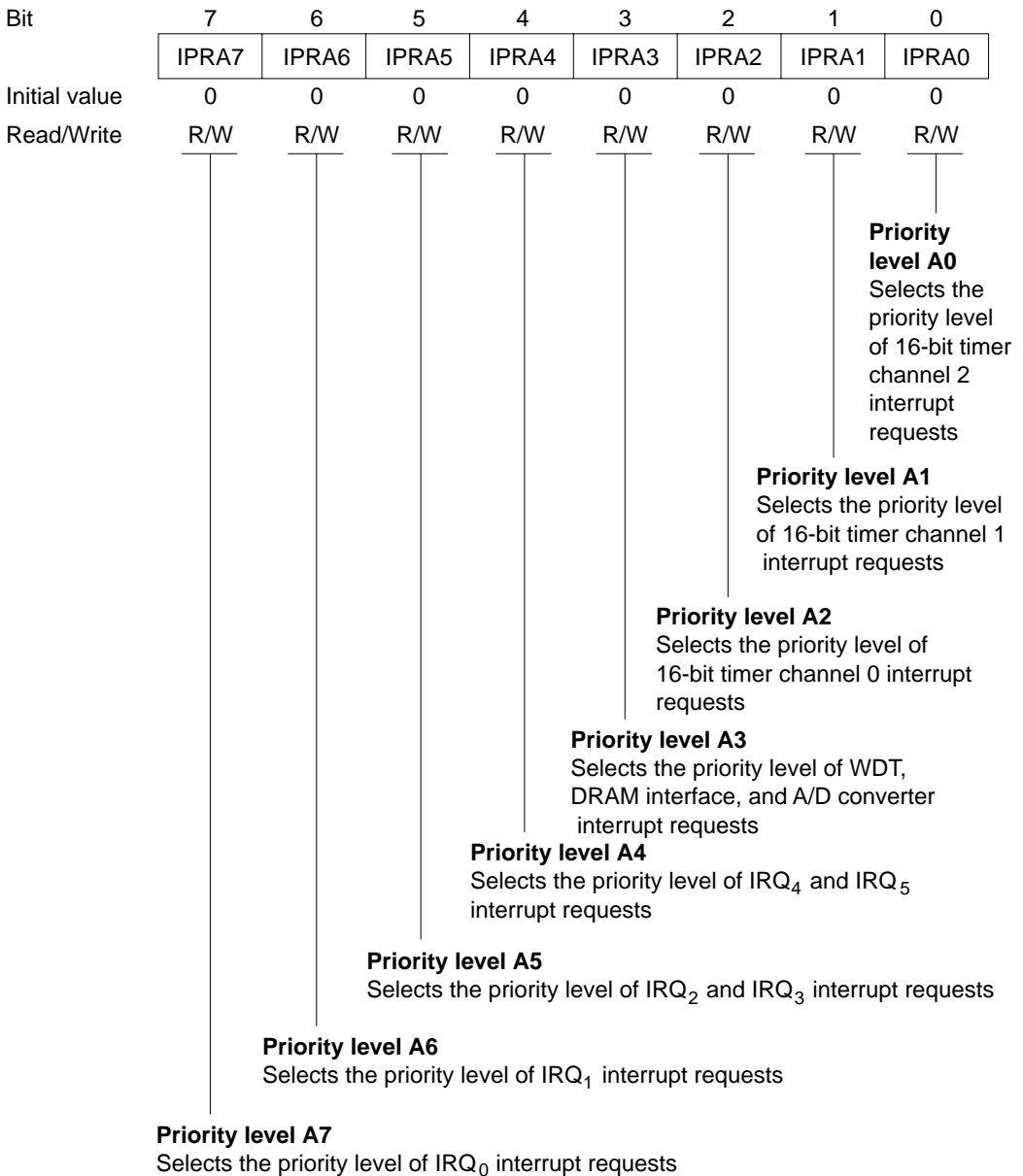
**Bit 2**

<b>NMIEG</b>	<b>Description</b>	
0	Interrupt is requested at falling edge of NMI input	(Initial value)
1	Interrupt is requested at rising edge of NMI input	

### 5.2.2 Interrupt Priority Registers A and B (IPRA, IPRB)

IPRA and IPRB are 8-bit readable/writable registers that control interrupt priority.

**Interrupt Priority Register A (IPRA):** IPRA is an 8-bit readable/writable register in which interrupt priority levels can be set.



IPRA is initialized to H'00 by a reset and in hardware standby mode.



**Bit 7—Priority Level A7 (IPRA7):** Selects the priority level of IRQ<sub>0</sub> interrupt requests.

**Bit 7**

<b>IPRA7</b>	<b>Description</b>	
0	IRQ <sub>0</sub> interrupt requests have priority level 0 (low priority)	(Initial value)
1	IRQ <sub>0</sub> interrupt requests have priority level 1 (high priority)	

**Bit 6—Priority Level A6 (IPRA6):** Selects the priority level of IRQ<sub>1</sub> interrupt requests.

**Bit 6**

<b>IPRA6</b>	<b>Description</b>	
0	IRQ <sub>1</sub> interrupt requests have priority level 0 (low priority)	(Initial value)
1	IRQ <sub>1</sub> interrupt requests have priority level 1 (high priority)	

**Bit 5—Priority Level A5 (IPRA5):** Selects the priority level of IRQ<sub>2</sub> and IRQ<sub>3</sub> interrupt requests.

**Bit 5**

<b>IPRA5</b>	<b>Description</b>	
0	IRQ <sub>2</sub> and IRQ <sub>3</sub> interrupt requests have priority level 0 (low priority)	(Initial value)
1	IRQ <sub>2</sub> and IRQ <sub>3</sub> interrupt requests have priority level 1 (high priority)	

**Bit 4—Priority Level A4 (IPRA4):** Selects the priority level of IRQ<sub>4</sub> and IRQ<sub>5</sub> interrupt requests.

**Bit 4**

<b>IPRA4</b>	<b>Description</b>	
0	IRQ <sub>4</sub> and IRQ <sub>5</sub> interrupt requests have priority level 0 (low priority)	(Initial value)
1	IRQ <sub>4</sub> and IRQ <sub>5</sub> interrupt requests have priority level 1 (high priority)	

**Bit 3—Priority Level A3 (IPRA3):** Selects the priority level of WDT, DRAM interface, and A/D converter interrupt requests.

**Bit 3**

**IPRA3 Description**

0	WDT, DRAM interface, and A/D converter interrupt requests have priority level 0 (low priority) (Initial value)
1	WDT, DRAM interface, and A/D converter interrupt requests have priority level 1 (high priority)

**Bit 2—Priority Level A2 (IPRA2):** Selects the priority level of 16-bit timer channel 0 interrupt requests.

**Bit 2**

**IPRA2 Description**

0	16-bit timer channel 0 interrupt requests have priority level 0 (low priority) (Initial value)
1	16-bit timer channel 0 interrupt requests have priority level 1 (high priority)

**Bit 1—Priority Level A1 (IPRA1):** Selects the priority level of 16-bit timer channel 1 interrupt requests.

**Bit 1**

**IPRA1 Description**

0	16-bit timer channel 1 interrupt requests have priority level 0 (low priority) (Initial value)
1	16-bit timer channel 1 interrupt requests have priority level 1 (high priority)

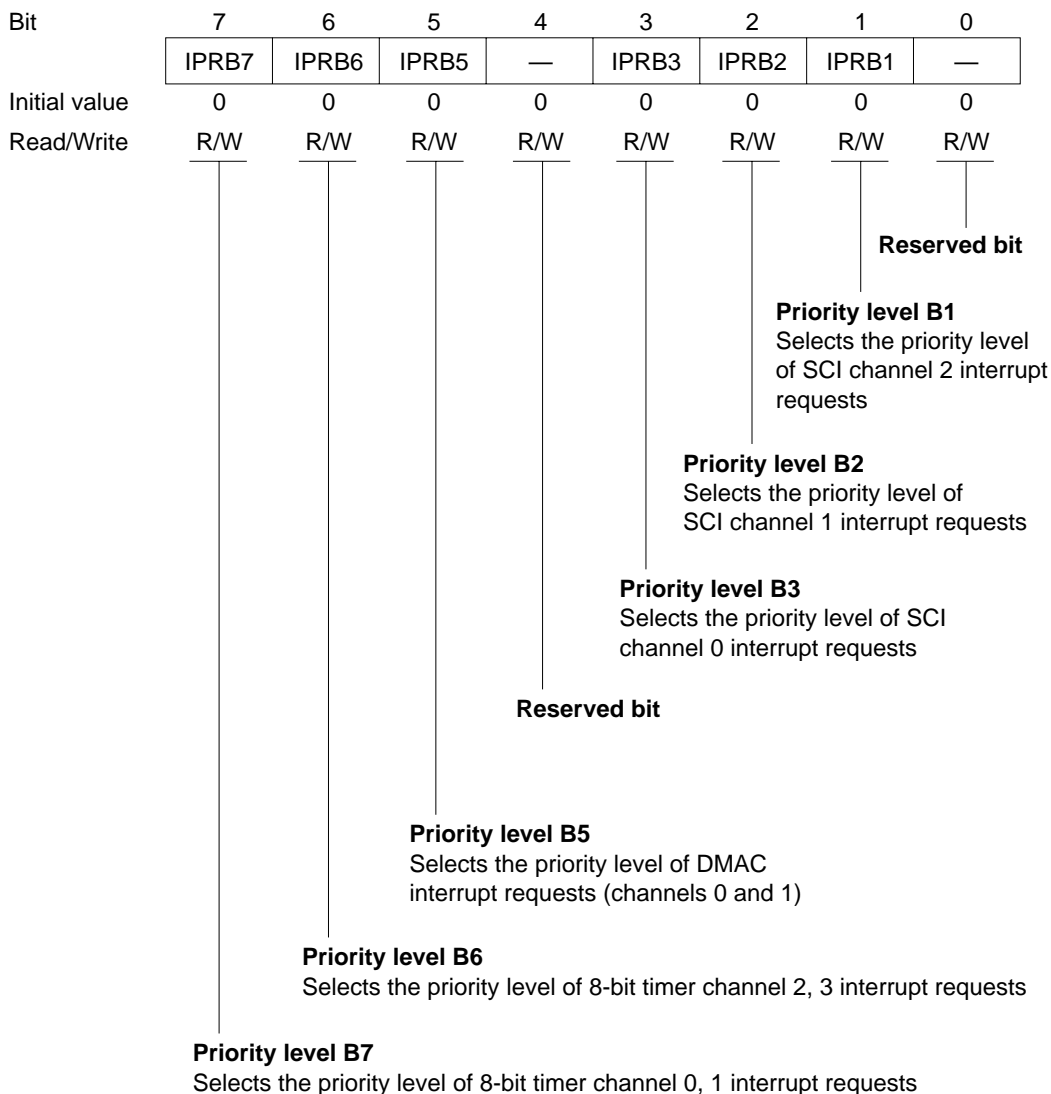
**Bit 0—Priority Level A0 (IPRA0):** Selects the priority level of 16-bit timer channel 2 interrupt requests.

**Bit 0**

**IPRA0 Description**

0	16-bit timer channel 2 interrupt requests have priority level 0 (low priority) (Initial value)
1	16-bit timer channel 2 interrupt requests have priority level 1 (high priority)

**Interrupt Priority Register B (IPRB):** IPRB is an 8-bit readable/writable register in which interrupt priority levels can be set.



IPRB is initialized to H'00 by a reset and in hardware standby mode.

**Bit 7—Priority Level B7 (IPRB7):** Selects the priority level of 8-bit timer channel 0, 1 interrupt requests.

**Bit 7**

**IPRB7**

**Description**

	Description
0	8-bit timer channel 0, 1 interrupt requests have priority level 0 (low priority)(Initial value)
1	8-bit timer channel 0, 1 interrupt requests have priority level 1 (high priority)

**Bit 6—Priority Level B6 (IPRB6):** Selects the priority level of 8-bit timer channel 2, 3 interrupt requests.

**Bit 6**

**IPRB6**

**Description**

	Description
0	8-bit timer channel 2, 3 interrupt requests have priority level 0 (low priority)(Initial value)
1	8-bit timer channel 2, 3 interrupt requests have priority level 1 (high priority)

**Bit 5—Priority Level B5 (IPRB5):** Selects the priority level of DMAC interrupt requests (channels 0 and 1).

**Bit 5**

**IPRB5**

**Description**

	Description
0	DMAC interrupt requests (channels 0 and 1) have priority level 0 (Initial value) (low priority)
1	DMAC interrupt requests (channels 0 and 1) have priority level 1 (high priority)

**Bit 4—Reserved:** This bit can be written and read, but it does not affect interrupt priority.

**Bit 3—Priority Level B3 (IPRB3):** Selects the priority level of SCI channel 0 interrupt requests.

**Bit 3**

<b>IPRB3</b>	<b>Description</b>	
0	SCI0 interrupt requests have priority level 0 (low priority)	(Initial value)
1	SCI0 interrupt requests have priority level 1 (high priority)	

**Bit 2—Priority Level B2 (IPRB2):** Selects the priority level of SCI channel 1 interrupt requests.

**Bit 2**

<b>IPRB2</b>	<b>Description</b>	
0	SCI1 interrupt requests have priority level 0 (low priority)	(Initial value)
1	SCI1 interrupt requests have priority level 1 (high priority)	

**Bit 1—Priority Level B1 (IPRB1):** Selects the priority level of SCI channel 2 interrupt requests.

**Bit 1**

<b>IPRB1</b>	<b>Description</b>	
0	SCI channel 2 interrupt requests have priority level 0 (low priority)	(Initial value)
1	SCI channel 2 interrupt requests have priority level 1 (high priority)	

**Bit 0—Reserved:** This bit can be written and read, but it does not affect interrupt priority.

### 5.2.3 IRQ Status Register (ISR)

ISR is an 8-bit readable/writable register that indicates the status of IRQ<sub>0</sub> to IRQ<sub>5</sub> interrupt requests.

Bit	7	6	5	4	3	2	1	0
	—	—	IRQ5F	IRQ4F	IRQ3F	IRQ2F	IRQ1F	IRQ0F
Initial value	0	0	0	0	0	0	0	0
Read/Write	—	—	R/(W)*	R/(W)*	R/(W)*	R/(W)*	R/(W)*	R/(W)*

**Reserved bits**
**IRQ<sub>5</sub> to IRQ<sub>0</sub> flags**  
These bits indicate IRQ<sub>5</sub> to IRQ<sub>0</sub> interrupt request status

Note: \* Only 0 can be written, to clear flags.

ISR is initialized to H'00 by a reset and in hardware standby mode.

**Bits 7 and 6—Reserved:** These bits can not be modified and are always read as 0.

**Bits 5 to 0—IRQ<sub>5</sub> to IRQ<sub>0</sub> Flags (IRQ5F to IRQ0F):** These bits indicate the status of IRQ<sub>5</sub> to IRQ<sub>0</sub> interrupt requests.

#### Bits 5 to 0

#### IRQ5F to IRQ0F Description

0	[Clearing conditions] 0 is written in $\overline{\text{IRQnF}}$ after reading the $\overline{\text{IRQnF}}$ flag when $\overline{\text{IRQnF}} = 1$ . $\overline{\text{IRQnSC}} = 0$ , $\overline{\text{IRQn}}$ input is high, and interrupt exception handling is carried out. $\overline{\text{IRQnSC}} = 1$ and $\overline{\text{IRQn}}$ interrupt exception handling is carried out.	(Initial value)
1	[Setting conditions] $\overline{\text{IRQnSC}} = 0$ and $\overline{\text{IRQn}}$ input is low. $\overline{\text{IRQnSC}} = 1$ and $\overline{\text{IRQn}}$ input changes from high to low.	

Note: n = 5 to 0

## 5.2.4 IRQ Enable Register (IER)

IER is an 8-bit readable/writable register that enables or disables IRQ<sub>5</sub> to IRQ<sub>0</sub> interrupt requests.

Bit	7	6	5	4	3	2	1	0
	—	—	IRQ5E	IRQ4E	IRQ3E	IRQ2E	IRQ1E	IRQ0E
Initial value	0	0	0	0	0	0	0	0
Read/Write	R/W	R/W	R/W	R/W	R/W	R/W	R/W	R/W

**Reserved bits**
**IRQ<sub>5</sub> to IRQ<sub>0</sub> enable**  
 These bits enable or disable IRQ<sub>5</sub> to IRQ<sub>0</sub> interrupts

IER is initialized to H'00 by a reset and in hardware standby mode.

**Bits 7 and 6—Reserved:** These bits can be written and read, but they do not enable or disable interrupts.

**Bits 5 to 0—IRQ<sub>5</sub> to IRQ<sub>0</sub> Enable (IRQ5E to IRQ0E):** These bits enable or disable IRQ<sub>5</sub> to IRQ<sub>0</sub> interrupts.

### Bits 5 to 0

#### IRQ5E to IRQ0E Description

0	IRQ <sub>5</sub> to IRQ <sub>0</sub> interrupts are disabled	(Initial value)
1	IRQ <sub>5</sub> to IRQ <sub>0</sub> interrupts are enabled	

### 5.2.5 IRQ Sense Control Register (ISCR)

ISCR is an 8-bit readable/writable register that selects level sensing or falling-edge sensing of the inputs at pins  $\overline{\text{IRQ}}_5$  to  $\overline{\text{IRQ}}_0$ .

Bit	7	6	5	4	3	2	1	0
	—	—	IRQ5SC	IRQ4SC	IRQ3SC	IRQ2SC	IRQ1SC	IRQ0SC
Initial value	0	0	0	0	0	0	0	0
Read/Write	R/W	R/W	R/W	R/W	R/W	R/W	R/W	R/W

**Reserved bits**

**IRQ<sub>5</sub> to IRQ<sub>0</sub> sense control**

These bits select level sensing or falling-edge sensing for IRQ<sub>5</sub> to IRQ<sub>0</sub> interrupts

ISCR is initialized to H'00 by a reset and in hardware standby mode.

**Bits 7 and 6—Reserved:** These bits can be written and read, but they do not select level or falling-edge sensing.

**Bits 5 to 0—IRQ<sub>5</sub> to IRQ<sub>0</sub> Sense Control (IRQ5SC to IRQ0SC):** These bits select whether interrupts IRQ<sub>5</sub> to IRQ<sub>0</sub> are requested by level sensing of pins  $\overline{\text{IRQ}}_5$  to  $\overline{\text{IRQ}}_0$ , or by falling-edge sensing.

**Bits 5 to 0**

**IRQ5SC to IRQ0SC Description**

0	Interrupts are requested when $\overline{\text{IRQ}}_5$ to $\overline{\text{IRQ}}_0$ inputs are low (Initial value)
1	Interrupts are requested by falling-edge input at $\overline{\text{IRQ}}_5$ to $\overline{\text{IRQ}}_0$



## 5.3 Interrupt Sources

The interrupt sources include external interrupts (NMI, IRQ<sub>0</sub> to IRQ<sub>5</sub>) and 36 internal interrupts.

### 5.3.1 External Interrupts

There are seven external interrupts: NMI, and IRQ<sub>0</sub> to IRQ<sub>5</sub>. Of these, NMI, IRQ<sub>0</sub>, IRQ<sub>1</sub>, and IRQ<sub>2</sub> can be used to exit software standby mode.

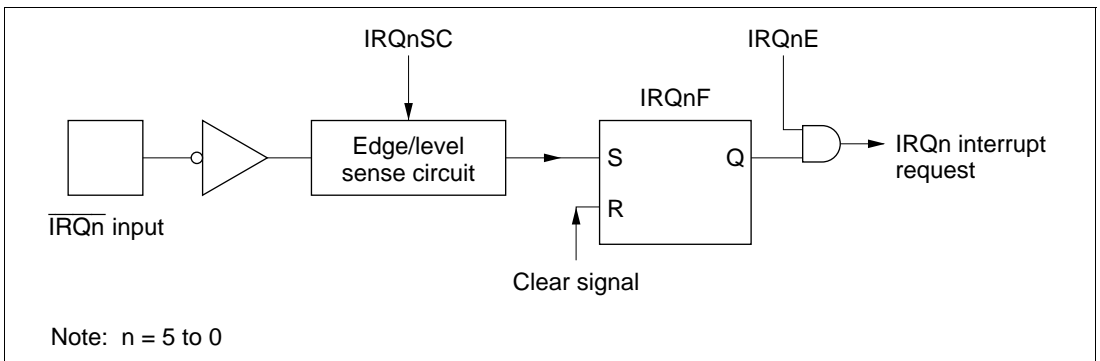
**NMI:** NMI is the highest-priority interrupt and is always accepted, regardless of the states of the I and UI bits in CCR\*. The NMIEG bit in SYSCR selects whether an interrupt is requested by the rising or falling edge of the input at the NMI pin. NMI interrupt exception handling has vector number 7.

Note: In the flash memory and flash memory R versions, NMI input is sometimes disabled. For details see 18.6.4, NMI Input Disable Conditions.

**IRQ<sub>0</sub> to IRQ<sub>5</sub> Interrupts:** These interrupts are requested by input signals at pins  $\overline{\text{IRQ}}_0$  to  $\overline{\text{IRQ}}_5$ . The IRQ<sub>0</sub> to IRQ<sub>5</sub> interrupts have the following features.

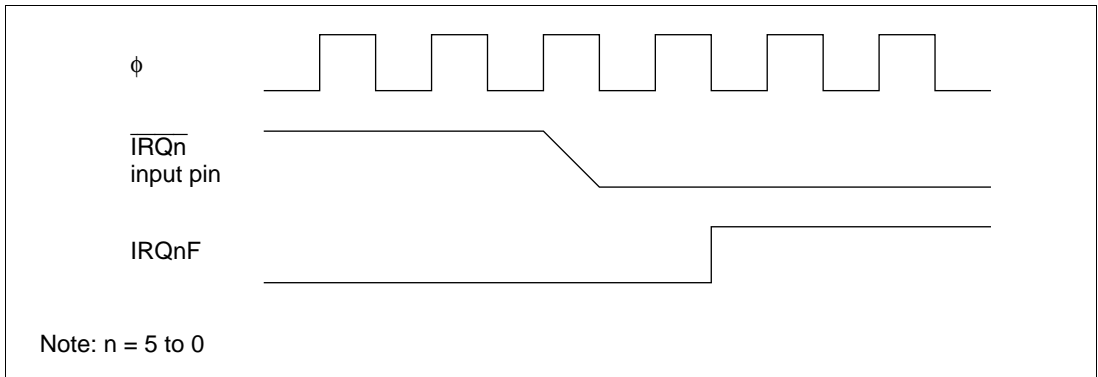
- ISCR settings can select whether an interrupt is requested by the low level of the input at pins  $\overline{\text{IRQ}}_0$  to  $\overline{\text{IRQ}}_5$ , or by the falling edge.
- IER settings can enable or disable the IRQ<sub>0</sub> to IRQ<sub>5</sub> interrupts. Interrupt priority levels can be assigned by four bits in IPRA (IPRA7 to IPRA4).
- The status of IRQ<sub>0</sub> to IRQ<sub>5</sub> interrupt requests is indicated in ISR. The ISR flags can be cleared to 0 by software.

Figure 5.2 shows a block diagram of interrupts IRQ<sub>0</sub> to IRQ<sub>5</sub>.



**Figure 5.2 Block Diagram of Interrupts IRQ<sub>0</sub> to IRQ<sub>5</sub>**

Figure 5.3 shows the timing of the setting of the interrupt flags (IRQnF).



**Figure 5.3 Timing of Setting of IRQnF**

Interrupts  $IRQ_0$  to  $IRQ_5$  have vector numbers 12 to 17. These interrupts are detected regardless of whether the corresponding pin is set for input or output. When using a pin for external interrupt input, clear its DDR bit to 0 and do not use the pin for chip select output, refresh output, SCI input/output, or A/D external trigger input.

### 5.3.2 Internal Interrupts

Thirty-Six internal interrupts are requested from the on-chip supporting modules.

- Each on-chip supporting module has status flags for indicating interrupt status, and enable bits for enabling or disabling interrupts.
- Interrupt priority levels can be assigned in IPRA and IPRB.
- 16-bit timer, SCI, and A/D converter interrupt requests can activate the DMAC, in which case no interrupt request is sent to the interrupt controller, and the I and UI bits are disregarded.

### 5.3.3 Interrupt Vector Table

Table 5.3 lists the interrupt sources, their vector addresses, and their default priority order. In the default priority order, smaller vector numbers have higher priority. The priority of interrupts other than NMI can be changed in IPRA and IPRB. The priority order after a reset is the default order shown in table 5.3.

**Table 5.3 Interrupt Sources, Vector Addresses, and Priority**

Interrupt Source	Origin	Vector Number	Vector Address*		IPR	Priority
			Advanced Mode	Normal Mode		
NMI	External pins	7	H'001C to H'001F	H'000E to H'000F	—	High
IRQ <sub>0</sub>		12	H'0030 to H'0033	H'0018 to H'0019	IPRA7	↑
IRQ <sub>1</sub>		13	H'0034 to H'0037	H'001A to H'001B	IPRA6	
IRQ <sub>2</sub>		14	H'0038 to H'003B	H'001C to H'001D	IPRA5	
IRQ <sub>3</sub>		15	H'003C to H'003F	H'001E to H'001F		
IRQ <sub>4</sub>		16	H'0040 to H'0043	H'0020 to H'0021	IPRA4	
IRQ <sub>5</sub>		17	H'0044 to H'0047	H'0022 to H'0023		
Reserved	—	18	H'0048 to H'004B	H'0024 to H'0025		
		19	H'004C to H'004F	H'0026 to H'0027		
WOVI (interval timer)	Watchdog timer	20	H'0050 to H'0053	H'0028 to H'0029	IPRA3	
CMI (compare match)	DRAM interface	21	H'0054 to H'0057	H'002A to H'002B		
Reserved	—	22	H'0058 to H'005B	H'002C to H'002D		
ADI (A/D end)	A/D	23	H'005C to H'005F	H'002E to H'002F		
IMIA0 (compare match/ input capture A0)	16-bit timer channel 0	24	H'0060 to H'0063	H'0030 to H'0031	IPRA2	
IMIB0 (compare match/ input capture B0)		25	H'0064 to H'0067	H'0032 to H'0033		
OVI0 (overflow 0)		26	H'0068 to H'006B	H'0034 to H'0035		
Reserved	—	27	H'006C to H'006F	H'0036 to H'0037		
IMIA1 (compare match/ inputcapture A1)	16-bit timer channel 1	28	H'0070 to H'0073	H'0038 to H'0039	IPRA1	
IMIB1 (compare match/ input capture B1)		29	H'0074 to H'0077	H'003A to H'003B		
OVI1 (overflow 1)		30	H'0078 to H'007B	H'003C to H'003D		
Reserved	—	31	H'007C to H'007F	H'003E to H'003F		Low

Note: \* Lower 16 bits of the address.

**Table 5.3 Interrupt Sources, Vector Addresses, and Priority (cont)**

Interrupt Source	Origin	Vector Number	Vector Address*		IPR	Priority
			Advanced Mode	Normal Mode		
IMIA2 (compare match/ input capture A2)	16-bit timer channel 2	32	H'0080 to H'0083	H'0040 to H'0041	IPRA0	High ↑
IMIB2 (compare match/ input capture B2)		33	H'0084 to H'0087	H'0042 to H'0043		
OVI2 (overflow 2)		34	H'0088 to H'008B	H'0044 to H'0045		
Reserved	—	35	H'008C to H'008F	H'0046 to H'0047		
CMIA0 (compare match A0)	8-bit timer channel 0/1	36	H'0090 to H'0093	H'0048 to H'0049	IPRB7	
CMIB0 (compare match B0)		37	H'0094 to H'0097	H'004A to H'004B		
CMIA1/CMIB1 (compare match A1/B1)		38	H'0098 to H'009B	H'004C to H'004D		
TOVI0/TOVI1 (overflow 0/1)		39	H'009C to H'009F	H'004E to H'004F		
CMIA2 (compare match A2)	8-bit timer channel 2/3	40	H'00A0 to H'00A3	H'0050 to H'0051	IPRB6	
CMIB2 (compare match B2)		41	H'00A4 to H'00A7	H'0052 to H'0053		
CMIA3/CMIB3 (compare match A3/B3)		42	H'00A8 to H'00AB	H'0054 to H'0055		
TOVI2/TOVI3 (overflow 2/3)		43	H'00AC to H'00AF	H'0056 to H'0057		
DEND0A	DMAC	44	H'00B0 to H'00B3	H'0058 to H'0059	IPRB5	
DEND0B		45	H'00B4 to H'00B7	H'005A to H'005B		
DEND1A		46	H'00B8 to H'00BB	H'005C to H'005D		
DEND1B		47	H'00BC to H'00BF	H'005E to H'005F		
Reserved	—	48	H'00C0 to H'00C3	H'0060 to H'0061	—	
		49	H'00C4 to H'00C7	H'0062 to H'0063		
		50	H'00C8 to H'00CB	H'0064 to H'0065		
		51	H'00CC to H'00CF	H'0066 to H'0067		

Note: \* Lower 16 bits of the address.

**Table 5.3 Interrupt Sources, Vector Addresses, and Priority (cont)**

Interrupt Source	Origin	Vector Number	Vector Address*		IPR	Priority
			Advanced Mode	Normal Mode		
ERI0 (receive error 0)	SCI channel 0	52	H'00D0 to H'00D3	H'0068 to H'0069	IPRB3	High ↑
RXI0 (receive data full 0)		53	H'00D4 to H'00D7	H'006A to H'006B		
TXI0 (transmit data empty 0)		54	H'00D8 to H'00DB	H'006C to H'006D		
TEI0 (transmit end 0)		55	H'00DC to H'00DF	H'006E to H'006F		
ERI1 (receive error 1)	SCI channel 1	56	H'00E0 to H'00E3	H'0070 to H'0071	IPRB2	
RXI1 (receive data full 1)		57	H'00E4 to H'00E7	H'0072 to H'0073		
TXI1 (transmit data empty 1)		58	H'00E8 to H'00EB	H'0074 to H'0075		
TEI1 (transmit end 1)		59	H'00EC to H'00EF	H'0076 to H'0077		
ERI2 (receive error 2)	SCI channel 2	60	H'00F0 to H'00F3	H'0078 to H'0079	IPRB1	
RXI2 (receive data full 2)		61	H'00F4 to H'00F7	H'007A to H'007B		
TXI2 (transmit data empty 2)		62	H'00F8 to H'00FB	H'007C to H'007D		
TEI2 (transmit end 2)		63	H'00FC to H'00FF	H'007E to H'007F		

Low

Note: \* Lower 16 bits of the address.

## 5.4 Interrupt Operation

### 5.4.1 Interrupt Handling Process

The H8/3067 Series handles interrupts differently depending on the setting of the UE bit. When UE = 1, interrupts are controlled by the I bit. When UE = 0, interrupts are controlled by the I and UI bits. Table 5.4 indicates how interrupts are handled for all setting combinations of the UE, I, and UI bits.

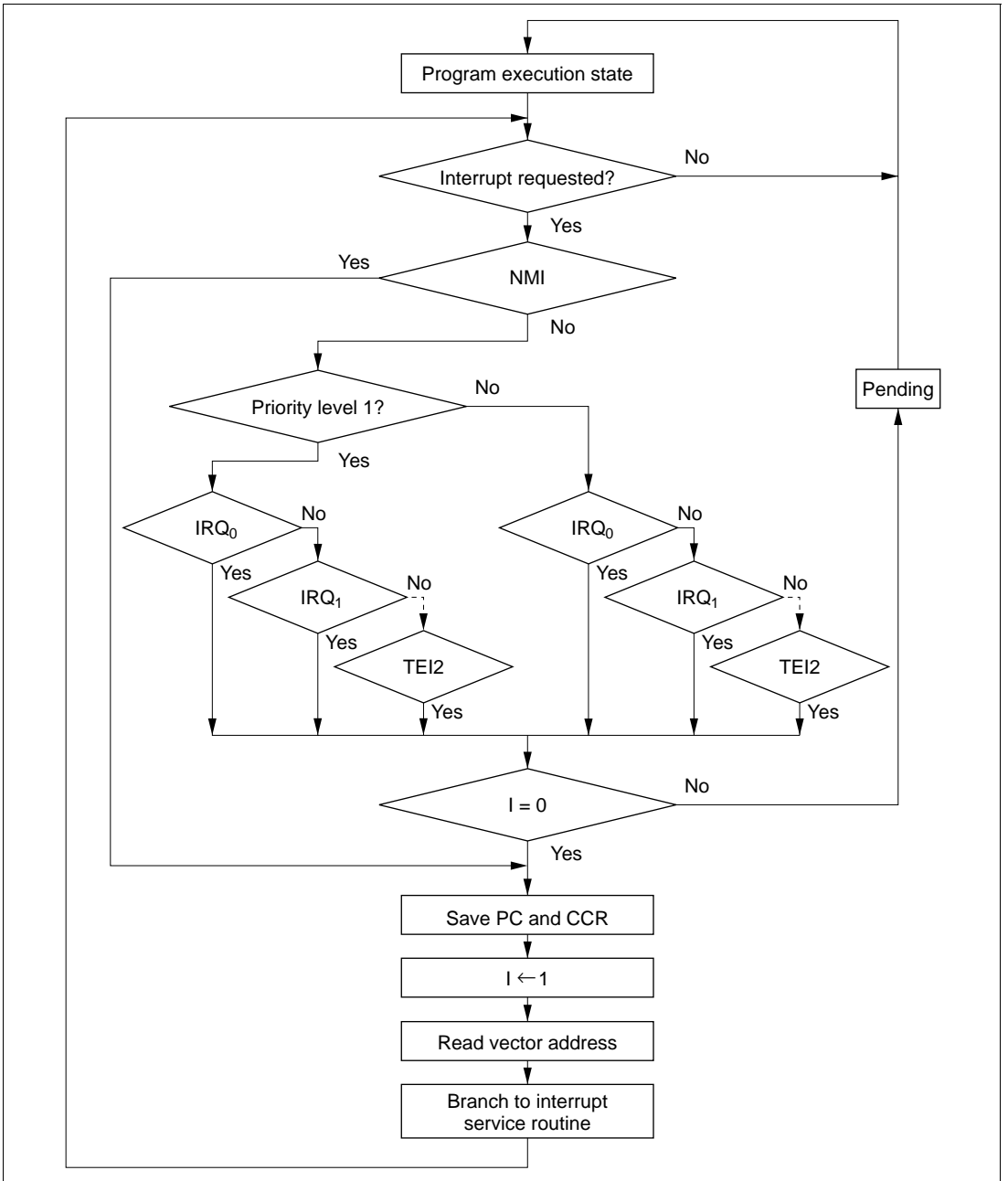
NMI interrupts are always accepted except in the reset and hardware standby states\*. IRQ interrupts and interrupts from the on-chip supporting modules have their own enable bits. Interrupt requests are ignored when the enable bits are cleared to 0.

Note: In the flash memory and flash memory R versions, NMI input is sometimes disabled. For details see 18.6.4, NMI Input Disable Conditions.

**Table 5.4 UE, I, and UI Bit Settings and Interrupt Handling**

SYSCR	CCR		Description
	I	UI	
1	0	—	All interrupts are accepted. Interrupts with priority level 1 have higher priority.
	1	—	No interrupts are accepted except NMI.
0	0	—	All interrupts are accepted. Interrupts with priority level 1 have higher priority.
		0	NMI and interrupts with priority level 1 are accepted.
	1	1	No interrupts are accepted except NMI.

**UE = 1:** Interrupts IRQ<sub>0</sub> to IRQ<sub>5</sub> and interrupts from the on-chip supporting modules can all be masked by the I bit in the CPU's CCR. Interrupts are masked when the I bit is set to 1, and unmasked when the I bit is cleared to 0. Interrupts with priority level 1 have higher priority. Figure 5.4 is a flowchart showing how interrupts are accepted when UE = 1.



**Figure 5.4 Process Up to Interrupt Acceptance when UE = 1**

- If an interrupt condition occurs and the corresponding interrupt enable bit is set to 1, an interrupt request is sent to the interrupt controller.
- When the interrupt controller receives one or more interrupt requests, it selects the highest-priority request, following the IPR interrupt priority settings, and holds other requests pending. If two or more interrupts with the same IPR setting are requested simultaneously, the interrupt controller follows the priority order shown in table 5.3.
- The interrupt controller checks the I bit. If the I bit is cleared to 0, the selected interrupt request is accepted. If the I bit is set to 1, only NMI is accepted; other interrupt requests are held pending.
- When an interrupt request is accepted, interrupt exception handling starts after execution of the current instruction has been completed.
- In interrupt exception handling, PC and CCR are saved to the stack area. The PC value that is saved indicates the address of the first instruction that will be executed after the return from the interrupt service routine.
- Next the I bit is set to 1 in CCR, masking all interrupts except NMI.
- The vector address of the accepted interrupt is generated, and the interrupt service routine starts executing from the address indicated by the contents of the vector address.

**UE = 0:** The I and UI bits in the CPU's CCR and the IPR bits enable three-level masking of  $IRQ_0$  to  $IRQ_5$  interrupts and interrupts from the on-chip supporting modules.

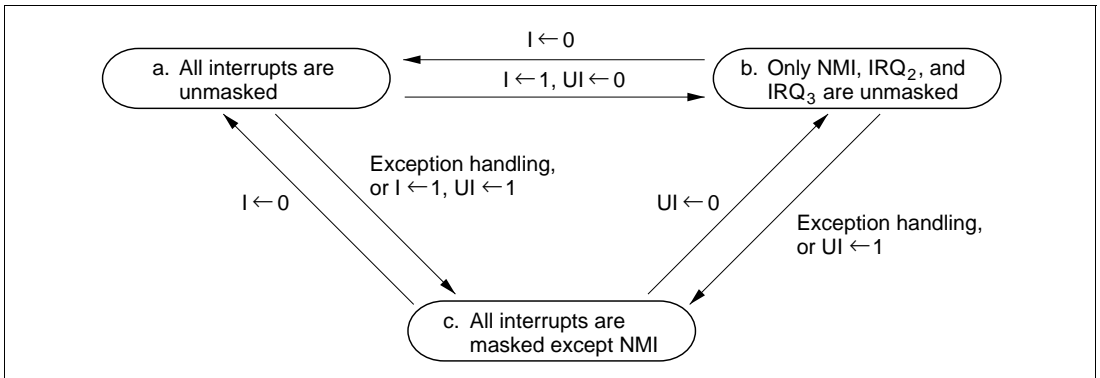
- Interrupt requests with priority level 0 are masked when the I bit is set to 1, and are unmasked when the I bit is cleared to 0.
- Interrupt requests with priority level 1 are masked when the I and UI bits are both set to 1, and are unmasked when either the I bit or the UI bit is cleared to 0.

For example, if the interrupt enable bits of all interrupt requests are set to 1, IPRA is set to H'20, and IPRB is set to H'00 (giving  $IRQ_2$  and  $IRQ_3$  interrupt requests priority over other interrupts), interrupts are masked as follows:

- a. If  $I = 0$ , all interrupts are unmasked (priority order:  $NMI > IRQ_2 > IRQ_3 > IRQ_0 \dots$ ).
- b. If  $I = 1$  and  $UI = 0$ , only NMI,  $IRQ_2$ , and  $IRQ_3$  are unmasked.
- c. If  $I = 1$  and  $UI = 1$ , all interrupts are masked except NMI.



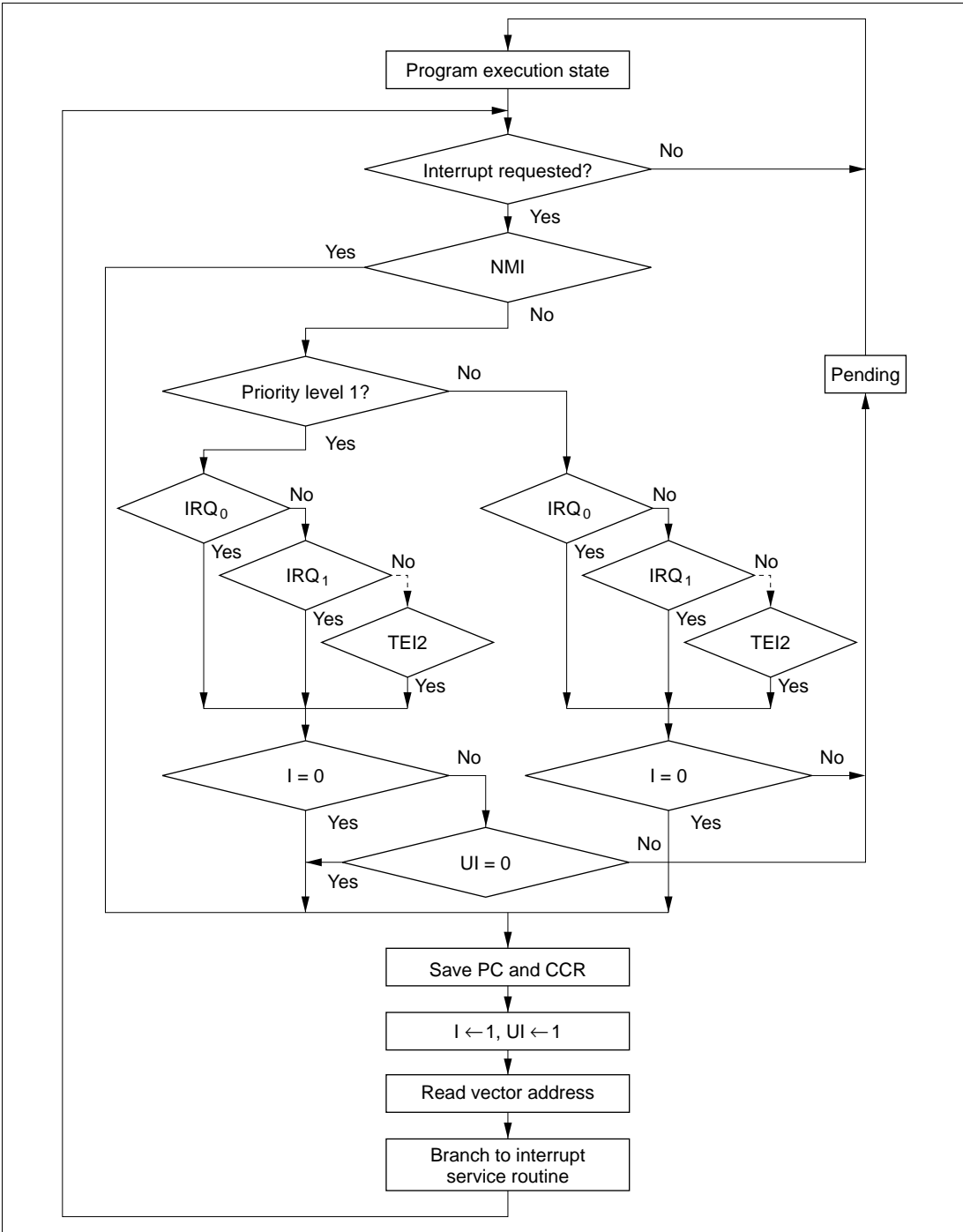
Figure 5.5 shows the transitions among the above states.



**Figure 5.5 Interrupt Masking State Transitions (Example)**

Figure 5.6 is a flowchart showing how interrupts are accepted when UE = 0.

- If an interrupt condition occurs and the corresponding interrupt enable bit is set to 1, an interrupt request is sent to the interrupt controller.
- When the interrupt controller receives one or more interrupt requests, it selects the highest-priority request, following the IPR interrupt priority settings, and holds other requests pending. If two or more interrupts with the same IPR setting are requested simultaneously, the interrupt controller follows the priority order shown in table 5.3.
- The interrupt controller checks the I bit. If the I bit is cleared to 0, the selected interrupt request is accepted regardless of its IPR setting, and regardless of the UI bit. If the I bit is set to 1 and the UI bit is cleared to 0, only NMI and interrupts with priority level 1 are accepted; interrupt requests with priority level 0 are held pending. If the I bit and UI bit are both set to 1, only NMI is accepted; all other interrupt requests are held pending.
- When an interrupt request is accepted, interrupt exception handling starts after execution of the current instruction has been completed.
- In interrupt exception handling, PC and CCR are saved to the stack area. The PC value that is saved indicates the address of the first instruction that will be executed after the return from the interrupt service routine.
- The I and UI bits are set to 1 in CCR, masking all interrupts except NMI.
- The vector address of the accepted interrupt is generated, and the interrupt service routine starts executing from the address indicated by the contents of the vector address.



**Figure 5.6 Process Up to Interrupt Acceptance when UE = 0**

## 5.4.2 Interrupt Sequence

Figure 5.7 shows the interrupt sequence in mode 2 when the program code and stack are in an external memory area accessed in two states via a 16-bit bus.

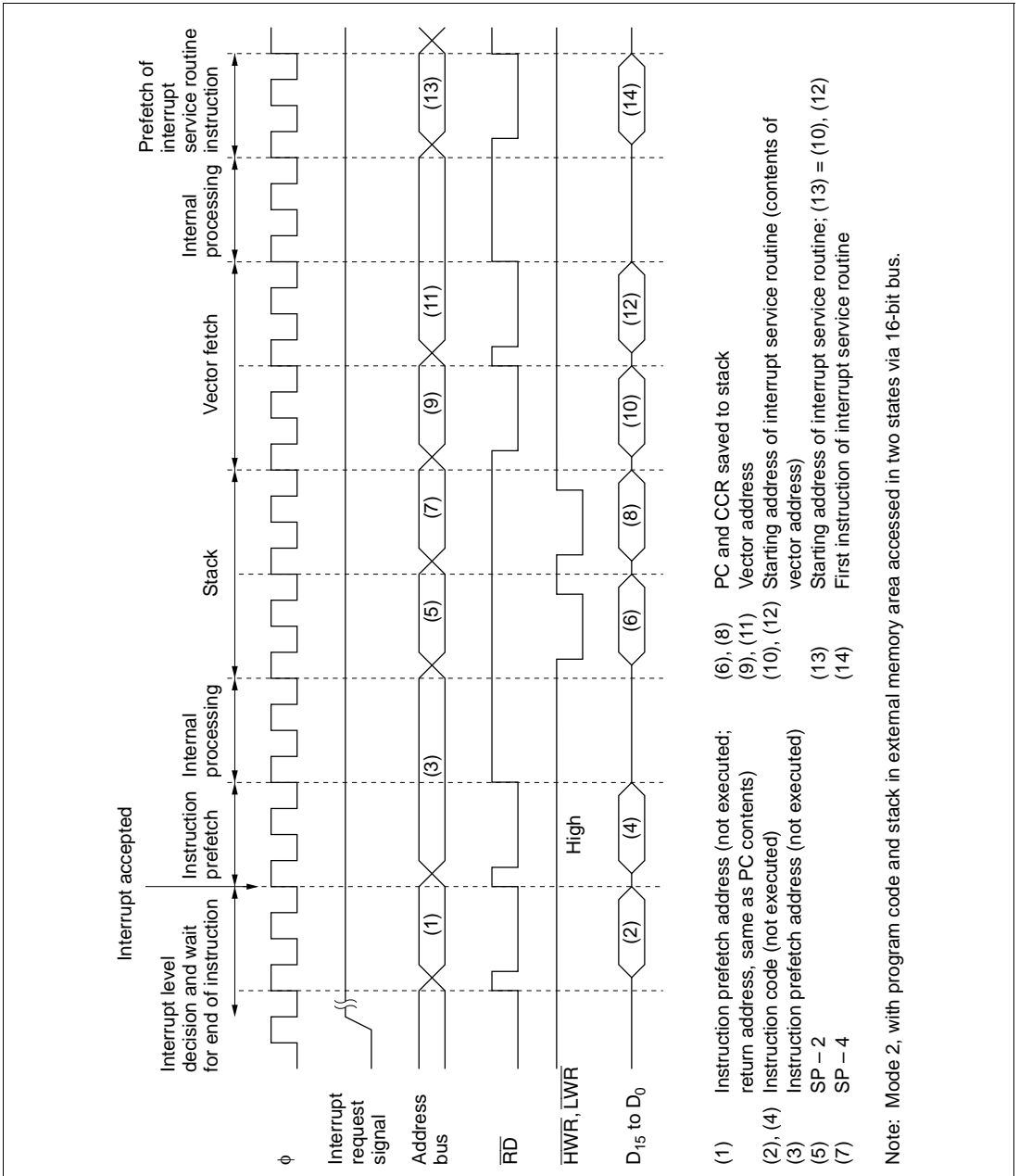


Figure 5.7 Interrupt Sequence

### 5.4.3 Interrupt Response Time

Table 5.5 indicates the interrupt response time from the occurrence of an interrupt request until the first instruction of the interrupt service routine is executed.

**Table 5.5 Interrupt Response Time**

No.	Item	On-Chip Memory	External Memory			
			8-Bit Bus		16-Bit Bus	
			2 States	3 States	2 States	3 States
1	Interrupt priority decision	2* <sup>1</sup>	2* <sup>1</sup>	2* <sup>1</sup>	2* <sup>1</sup>	2* <sup>1</sup>
2	Maximum number of states until end of current instruction	1 to 23	1 to 27	1 to 31* <sup>4</sup>	1 to 23	1 to 25* <sup>4</sup>
3	Saving PC and CCR to stack	4	8	12* <sup>4</sup>	4	6* <sup>4</sup>
4	Vector fetch	4	8	12* <sup>4</sup>	4	6* <sup>4</sup>
5	Instruction prefetch* <sup>2</sup>	4	8	12* <sup>4</sup>	4	6* <sup>4</sup>
6	Internal processing* <sup>3</sup>	4	4	4	4	4
Total		19 to 41	31 to 57	43 to 73	19 to 41	25 to 49

Notes: 1. 1 state for internal interrupts.

2. Prefetch after the interrupt is accepted and prefetch of the first instruction in the interrupt service routine.

3. Internal processing after the interrupt is accepted and internal processing after vector fetch.

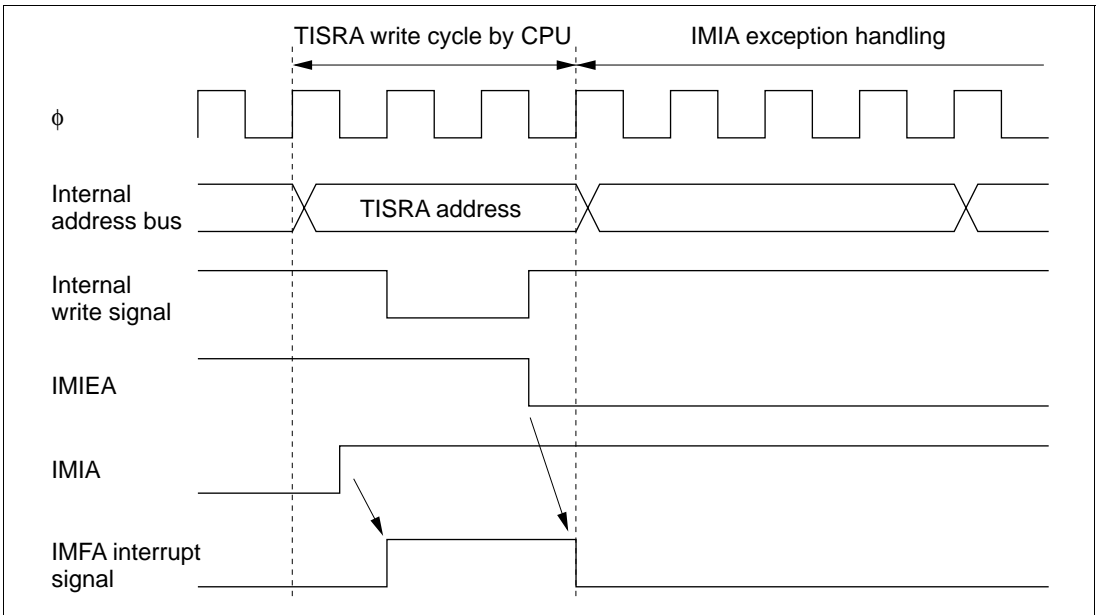
4. The number of states increases if wait states are inserted in external memory access.

## 5.5 Usage Notes

### 5.5.1 Contention between Interrupt and Interrupt-Disabling Instruction

When an instruction clears an interrupt enable bit to 0 to disable the interrupt, the interrupt is not disabled until after execution of the instruction is completed. If an interrupt occurs while a BCLR, MOV, or other instruction is being executed to clear its interrupt enable bit to 0, at the instant when execution of the instruction ends the interrupt is still enabled, so its interrupt exception handling is carried out. If a higher-priority interrupt is also requested, however, interrupt exception handling for the higher-priority interrupt is carried out, and the lower-priority interrupt is ignored. This also applies to the clearing of an interrupt flag to 0.

Figure 5.8 shows an example in which an IMIEA bit is cleared to 0 in the 16-bit timer's TISRA register.



**Figure 5.8 Contention between Interrupt and Interrupt-Disabling Instruction**

This type of contention will not occur if the interrupt is masked when the interrupt enable bit or flag is cleared to 0.

## 5.5.2 Instructions that Inhibit Interrupts

The LDC, ANDC, ORC, and XORC instructions inhibit interrupts. When an interrupt occurs, after determining the interrupt priority, the interrupt controller requests a CPU interrupt. If the CPU is currently executing one of these interrupt-inhibiting instructions, however, when the instruction is completed the CPU always continues by executing the next instruction.

## 5.5.3 Interrupts during EEPMOV Instruction Execution

The EEPMOV.B and EEPMOV.W instructions differ in their reaction to interrupt requests.

When the EEPMOV.B instruction is executing a transfer, no interrupts are accepted until the transfer is completed, not even NMI.

When the EEPMOV.W instruction is executing a transfer, interrupt requests other than NMI are not accepted until the transfer is completed. If NMI is requested, NMI exception handling starts at a transfer cycle boundary. The PC value saved on the stack is the address of the next instruction. Programs should be coded as follows to allow for NMI interrupts during EEPMOV.W execution:

```
L1: EEPMOV.W  
    MOV.W R4,R4  
    BNE L1
```

# Section 6 Bus Controller

## 6.1 Overview

The H8/3067 Series has an on-chip bus controller (BSC) that manages the external address space divided into eight areas. The bus specifications, such as bus width and number of access states, can be set independently for each area, enabling multiple memories to be connected easily.

The bus controller also has a bus arbitration function that controls the operation of the internal bus masters—the CPU, DMA controller (DMAC), and DRAM interface and can release the bus to an external device.

### 6.1.1 Features

The features of the bus controller are listed below.

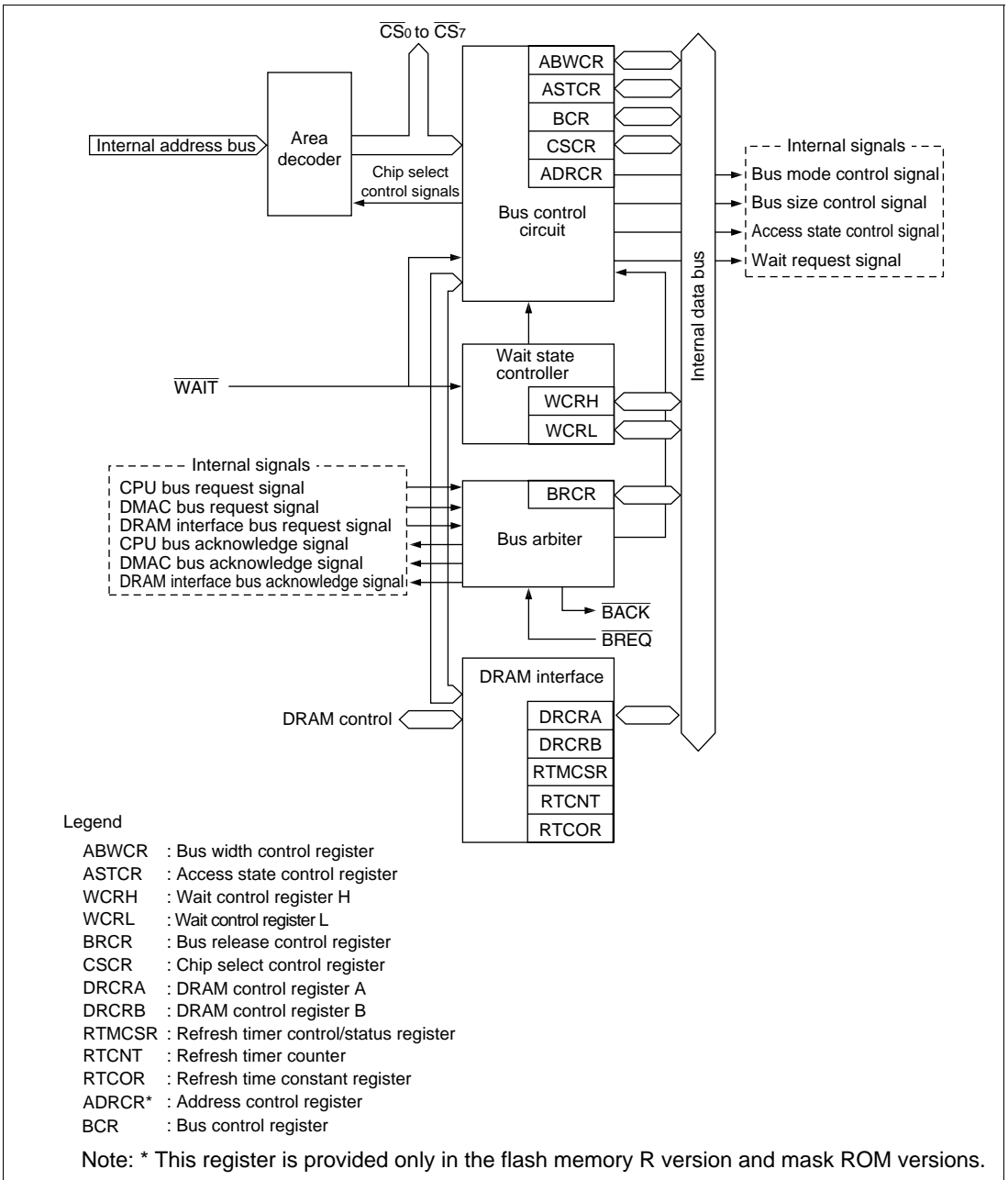
- Manages external address space in area units
  - Manages the external space as eight areas (0 to 7) of 128 kbytes in 1M-byte modes, or 2 Mbytes in 16-Mbyte modes
  - Bus specifications can be set independently for each area
  - DRAM/burst ROM interfaces can be set
- Basic bus interface
  - Chip select ( $\overline{CS}_0$  to  $\overline{CS}_7$ ) can be output for areas 0 to 7
  - 8-bit access or 16-bit access can be selected for each area
  - Two-state access or three-state access can be selected for each area
  - Program wait states can be inserted for each area
  - Pin wait insertion capability is provided
- DRAM interface
  - DRAM interface can be set for areas 2 to 5
  - Row address/column address multiplexed output (8/9/10 bits)
  - 2-CAS byte access mode
  - Burst operation (fast page mode)
  - $T_p$  cycle insertion to secure RAS precharging time
  - Choice of CAS-before-RAS refreshing or self-refreshing
- Burst ROM interface
  - Burst ROM interface can be set for area 0
  - Selection of two- or three-state burst access

- Idle cycle insertion
  - An idle cycle can be inserted in case of an external read cycle between different areas
  - An idle cycle can be inserted when an external read cycle is immediately followed by an external write cycle
- Bus arbitration function
  - A built-in bus arbiter grants the bus right to the CPU, DMAC, DRAM interface, or an external bus master
- Other features
  - Refresh counter (refresh timer) can be used as interval timer
  - Choice of two address update modes (in flash memory R version and mask ROM versions)



## 6.1.2 Block Diagram

Figure 6.1 shows a block diagram of the bus controller.



**Figure 6.1 Block Diagram of Bus Controller**

### 6.1.3 Pin Configuration

Table 6.1 summarizes the input/output pins of the bus controller.

**Table 6.1 Bus Controller Pins**

<b>Name</b>	<b>Abbreviation</b>	<b>I/O</b>	<b>Function</b>
Chip select 0 to 7	$\overline{CS}_0$ to $\overline{CS}_7$	Output	Strobe signals selecting areas 0 to 7
Address strobe	$\overline{AS}$	Output	Strobe signal indicating valid address output on the address bus
Read	$\overline{RD}$	Output	Strobe signal indicating reading from the external address space
High write	$\overline{HWR}$	Output	Strobe signal indicating writing to the external address space, with valid data on the upper data bus ( $D_{15}$ to $D_8$ )
Low write	$\overline{LWR}$	Output	Strobe signal indicating writing to the external address space, with valid data on the lower data bus ( $D_7$ to $D_0$ )
Wait	$\overline{WAIT}$	Input	Wait request signal for access to external three-state access areas
Bus request	$\overline{BREQ}$	Input	Request signal for releasing the bus to an external device
Bus acknowledge	$\overline{BACK}$	Output	Acknowledge signal indicating release of the bus to an external device

## 6.1.4 Register Configuration

Table 6.2 summarizes the bus controller's registers.

**Table 6.2 Bus Controller Registers**

Address* <sup>1</sup>	Name	Abbreviation	R/W	Initial Value
H'EE020	Bus width control register	ABWCR	R/W	H'FF* <sup>2</sup>
H'EE021	Access state control register	ASTCR	R/W	H'FF
H'EE022	Wait control register H	WCRH	R/W	H'FF
H'EE023	Wait control register L	WCRL	R/W	H'FF
H'EE013	Bus release control register	BRCR	R/W	H'FE* <sup>3</sup>
H'EE01F	Chip select control register	CSCR	R/W	H'0F
H'EE01E	Address control register* <sup>4</sup>	ADRCR	R/W	H'FF
H'EE024	Bus control register	BCR	R/W	H'C6
H'EE026	DRAM control register A	DRCRA	R/W	H'10
H'EE027	DRAM control register B	DRCRB	R/W	H'08
H'EE028	Refresh timer control/status register	RTMCSR	R(W)* <sup>5</sup>	H'07
H'EE029	Refresh timer counter	RTCNT	R/W	H'00
H'EE02A	Refresh time constant register	RTCOR	R/W	H'FF

- Notes:
1. Lower 20 bits of the address in advanced mode.
  2. In modes 2 and 4, the initial value is H'00.
  3. In modes 3 and 4, the initial value is H'EE.
  4. This register is provided only in the flash memory R version and mask ROM versions.
  5. For Bit 7, only 0 can be written to clear the flag.

## 6.2 Register Descriptions

### 6.2.1 Bus Width Control Register (ABWCR)

ABWCR is an 8-bit readable/writable register that selects 8-bit or 16-bit access for each area.

Bit		7	6	5	4	3	2	1	0
		ABW7	ABW6	ABW5	ABW4	ABW3	ABW2	ABW1	ABW0
Modes 1, 3, 5, 6, and 7	Initial value	1	1	1	1	1	1	1	1
	Read/Write	R/W	R/W	R/W	R/W	R/W	R/W	R/W	R/W
Modes 2 and 4	Initial value	0	0	0	0	0	0	0	0
	Read/Write	R/W	R/W	R/W	R/W	R/W	R/W	R/W	R/W

When ABWCR contains H'FF (selecting 8-bit access for all areas), the chip operates in 8-bit bus mode: the upper data bus ( $D_{15}$  to  $D_8$ ) is valid, and port 4 is an input/output port. When at least one bit is cleared to 0 in ABWCR, the chip operates in 16-bit bus mode with a 16-bit data bus ( $D_{15}$  to  $D_0$ ). In modes 1, 3, 5, 6, and 7, ABWCR is initialized to H'FF by a reset and in hardware standby mode. In modes 2 and 4, ABWCR is initialized to H'00 by a reset and in hardware standby mode. It is not initialized in software standby mode.

**Bits 7 to 0—Area 7 to 0 Bus Width Control (ABW7 to ABW0):** These bits select 8-bit access or 16-bit access for the corresponding areas.

#### Bits 7 to 0

#### ABW7 to ABW0 Description

ABW7 to ABW0	Description
0	Areas 7 to 0 are 16-bit access areas
1	Areas 7 to 0 are 8-bit access areas

ABWCR specifies the data bus width of external memory areas. The data bus width of on-chip memory and registers is fixed, and does not depend on ABWCR settings. These settings are therefore meaningless in the single-chip modes (modes 6 and 7).

## 6.2.2 Access State Control Register (ASTCR)

ASTCR is an 8-bit readable/writable register that selects whether each area is accessed in two states or three states.

Bit	7	6	5	4	3	2	1	0
	AST7	AST6	AST5	AST4	AST3	AST2	AST1	AST0
Initial value	1	1	1	1	1	1	1	1
Read/Write	R/W	R/W	R/W	R/W	R/W	R/W	R/W	R/W

Bits selecting number of states for access to each area

ASTCR is initialized to H'FF by a reset and in hardware standby mode. It is not initialized in software standby mode.

**Bits 7 to 0—Area 7 to 0 Access State Control (AST7 to AST0):** These bits select whether the corresponding area is accessed in two or three states.

### Bits 7 to 0

#### AST7 to AST0 Description

0	Areas 7 to 0 are accessed in two states	
1	Areas 7 to 0 are accessed in three states	(Initial value)

ASTCR specifies the number of states in which external areas are accessed. On-chip memory and registers are accessed in a fixed number of states that does not depend on ASTCR settings. These settings are therefore meaningless in the single-chip modes (modes 6 and 7).

When the corresponding area is designated as DRAM space by bits DRAS2 to DRAS0 in DRAM control register A (DRCRA), the number of access states does not depend on the AST bit setting. When an AST bit is cleared to 0, programmable wait insertion is not performed.

## 6.2.3 Wait Control Registers H and L (WCRH, WCRL)

WCRH and WCRL are 8-bit readable/writable registers that select the number of program wait states for each area.

On-chip memory and registers are accessed in a fixed number of states that does not depend on WCRH/WCRL settings.

WCRH and WCRL are initialized to H'FF by a reset and in hardware standby mode. They are not initialized in software standby mode.

## WCRH

Bit	7	6	5	4	3	2	1	0
	W71	W70	W61	W60	W51	W50	W41	W40
Initial value	1	1	1	1	1	1	1	1
Read/Write	R/W	R/W	R/W	R/W	R/W	R/W	R/W	R/W

**Bits 7 and 6—Area 7 Wait Control 1 and 0 (W71, W70):** These bits select the number of program wait states when area 7 in external space is accessed while the AST7 bit in ASTCR is set to 1.

Bit 7 W71	Bit 6 W70	Description
0	0	Program wait not inserted when external space area 7 is accessed
	1	1 program wait state inserted when external space area 7 is accessed
1	0	2 program wait states inserted when external space area 7 is accessed
	1	3 program wait states inserted when external space area 7 is accessed (Initial value)

**Bits 5 and 4—Area 6 Wait Control 1 and 0 (W61, W60):** These bits select the number of program wait states when area 6 in external space is accessed while the AST6 bit in ASTCR is set to 1.

Bit 5 W61	Bit 4 W60	Description
0	0	Program wait not inserted when external space area 6 is accessed
	1	1 program wait state inserted when external space area 6 is accessed
1	0	2 program wait states inserted when external space area 6 is accessed
	1	3 program wait states inserted when external space area 6 is accessed (Initial value)

**Bits 3 and 2—Area 5 Wait Control 1 and 0 (W51, W50):** These bits select the number of program wait states when area 5 in external space is accessed while the AST5 bit in ASTCR is set to 1.

Bit 3 W51	Bit 2 W50	Description
0	0	Program wait not inserted when external space area 5 is accessed
	1	1 program wait state inserted when external space area 5 is accessed
1	0	2 program wait states inserted when external space area 5 is accessed
	1	3 program wait states inserted when external space area 5 is accessed (Initial value)

**Bits 1 and 0—Area 4 Wait Control 1 and 0 (W41, W40):** These bits select the number of program wait states when area 4 in external space is accessed while the AST4 bit in ASTCR is set to 1.

Bit 1 W41	Bit 0 W40	Description
0	0	Program wait not inserted when external space area 4 is accessed
	1	1 program wait state inserted when external space area 4 is accessed
1	0	2 program wait states inserted when external space area 4 is accessed
	1	3 program wait states inserted when external space area 4 is accessed (Initial value)

## WCRL

Bit	7	6	5	4	3	2	1	0
	W31	W30	W21	W20	W11	W10	W01	W00
Initial value	1	1	1	1	1	1	1	1
Read/Write	R/W	R/W	R/W	R/W	R/W	R/W	R/W	R/W

**Bits 7 and 6—Area 3 Wait Control 1 and 0 (W31, W30):** These bits select the number of program wait states when area 3 in external space is accessed while the AST3 bit in ASTCR is set to 1.

Bit 7 W31	Bit 6 W30	Description
0	0	Program wait not inserted when external space area 3 is accessed
	1	1 program wait state inserted when external space area 3 is accessed
1	0	2 program wait states inserted when external space area 3 is accessed
	1	3 program wait states inserted when external space area 3 is accessed (Initial value)

**Bits 5 and 4—Area 2 Wait Control 1 and 0 (W21, W20):** These bits select the number of program wait states when area 2 in external space is accessed while the AST2 bit in ASTCR is set to 1.

Bit 5 W21	Bit 4 W20	Description
0	0	Program wait not inserted when external space area 2 is accessed
	1	1 program wait state inserted when external space area 2 is accessed
1	0	2 program wait states inserted when external space area 2 is accessed
	1	3 program wait states inserted when external space area 2 is accessed (Initial value)

**Bits 3 and 2—Area 1 Wait Control 1 and 0 (W11, W10):** These bits select the number of program wait states when area 1 in external space is accessed while the AST1 bit in ASTCR is set to 1.

Bit 3 W11	Bit 2 W10	Description
0	0	Program wait not inserted when external space area 1 is accessed
	1	1 program wait state inserted when external space area 1 is accessed
1	0	2 program wait states inserted when external space area 1 is accessed
	1	3 program wait states inserted when external space area 1 is accessed (Initial value)

**Bits 1 and 0—Area 0 Wait Control 1 and 0 (W01, W00):** These bits select the number of program wait states when area 0 in external space is accessed while the AST0 bit in ASTCR is set to 1.

Bit 1 W01	Bit 0 W00	Description
0	0	Program wait not inserted when external space area 0 is accessed
	1	1 program wait state inserted when external space area 0 is accessed
1	0	2 program wait states inserted when external space area 0 is accessed
	1	3 program wait states inserted when external space area 0 is accessed (Initial value)



## 6.2.4 Bus Release Control Register (BRCR)

BRCR is an 8-bit readable/writable register that enables address output on bus lines  $A_{23}$  to  $A_{20}$  and enables or disables release of the bus to an external device.

Bit	7	6	5	4	3	2	1	0
	A23E	A22E	A21E	A20E	—	—	—	BRLE
Modes 1, 2, 6, and 7	Initial value	1	1	1	1	1	1	0
	Read/Write	—	—	—	—	—	—	R/W
Modes 3 and 4	Initial value	1	1	0	1	1	1	0
	Read/Write	R/W	R/W	R/W	—	—	—	R/W
Mode 5	Initial value	1	1	1	1	1	1	0
	Read/Write	R/W	R/W	R/W	R/W	—	—	R/W

<p><b>Address 23 to 20 enable</b> These bits enable <math>PA_7</math> to <math>PA_4</math> to be used for <math>A_{23}</math> to <math>A_{20}</math> address output</p>	<p>Reserved bits</p>	<p><b>Bus release enable</b> Enables or disables release of the bus to an external device</p>
---	----------------------	---

BRCR is initialized to H'FE in modes 1, 2, 5, 6, and 7, and to H'EE in modes 3 and 4, by a reset and in hardware standby mode. It is not initialized in software standby mode.

**Bit 7—Address 23 Enable (A23E):** Enables  $PA_4$  to be used as the  $A_{23}$  address output pin. Writing 0 in this bit enables  $A_{23}$  output from  $PA_4$ . In modes other than 3, 4, and 5, this bit cannot be modified and  $PA_4$  has its ordinary port functions.

### Bit 7

A23E	Description
0	$PA_4$ is the $A_{23}$ address output pin
1	$PA_4$ is an input/output pin <span style="float: right;">(Initial value)</span>

**Bit 6—Address 22 Enable (A22E):** Enables  $PA_5$  to be used as the  $A_{22}$  address output pin. Writing 0 in this bit enables  $A_{22}$  output from  $PA_5$ . In modes other than 3, 4, and 5, this bit cannot be modified and  $PA_5$  has its ordinary port functions.

### Bit 6

A22E	Description
0	$PA_5$ is the $A_{22}$ address output pin
1	$PA_5$ is an input/output pin <span style="float: right;">(Initial value)</span>

**Bit 5—Address 21 Enable (A21E):** Enables PA<sub>6</sub> to be used as the A<sub>21</sub> address output pin. Writing 0 in this bit enables A<sub>21</sub> output from PA<sub>6</sub>. In modes other than 3, 4, and 5, this bit cannot be modified and PA<sub>6</sub> has its ordinary port functions.

**Bit 5**

A21E	Description
0	PA <sub>6</sub> is the A <sub>21</sub> address output pin
1	PA <sub>6</sub> is an input/output pin (Initial value)

**Bit 4—Address 20 Enable (A20E):** Enables PA<sub>7</sub> to be used as the A<sub>20</sub> address output pin. Writing 0 in this bit enables A<sub>20</sub> output from PA<sub>7</sub>. This bit can only be modified in mode 5.

**Bit 4**

A20E	Description
0	PA <sub>7</sub> is the A <sub>20</sub> address output pin (Initial value when in mode 3 or 4)
1	PA <sub>7</sub> is an input/output pin (Initial value when in mode 1, 2, 5, 6 or 7)

**Bits 3 to 1—Reserved:** These bits cannot be modified and are always read as 1.

**Bit 0—Bus Release Enable (BRLE):** Enables or disables release of the bus to an external device.

**Bit 0**

BRLE	Description
0	The bus cannot be released to an external device BREQ and BACK can be used as input/output pins (Initial value)
1	The bus can be released to an external device

### 6.2.5 Bus Control Register (BCR)

Bit	7	6	5	4	3	2	1	0
	ICIS1	ICIS0	BROME	BRSTS1	BRSTS0	—	RDEA	WAITE
Initial value	1	1	0	0	0	1	1	0
Read/Write	R/W	R/W	R/W	R/W	R/W	—	R/W	R/W

BCR is an 8-bit readable/writable register that enables or disables idle cycle insertion, selects the area division unit, and enables or disables  $\overline{\text{WAIT}}$  pin input.

BCR is initialized to H'C6 by a reset and in hardware standby mode. It is not initialized in software standby mode.

**Bit 7—Idle Cycle Insertion 1 (ICIS1):** Selects whether one idle cycle state is to be inserted between bus cycles in case of consecutive external read cycles for different areas.

**Bit 7**

<b>ICIS1</b>	<b>Description</b>
0	No idle cycle inserted in case of consecutive external read cycles for different areas
1	Idle cycle inserted in case of consecutive external read cycles for different areas (Initial value)

**Bit 6—Idle Cycle Insertion 0 (ICIS0):** Selects whether one idle cycle state is to be inserted between bus cycles in case of consecutive external read and write cycles.

**Bit 6**

<b>ICIS0</b>	<b>Description</b>
0	No idle cycle inserted in case of consecutive external read and write cycles
1	Idle cycle inserted in case of consecutive external read and write cycles (Initial value)

**Bit 5—Burst ROM Enable (BROME):** Selects whether area 0 is a burst ROM interface area.

**Bit 5**

<b>BROME</b>	<b>Description</b>
0	Area 0 is a basic bus interface area (Initial value)
1	Area 0 is a burst ROM interface area

**Bit 4—Burst Cycle Select 1 (BRSTS1):** Selects the number of burst cycle states for the burst ROM interface.

**Bit 4**

<b>BRSTS1</b>	<b>Description</b>
0	Burst access cycle comprises 2 states (Initial value)
1	Burst access cycle comprises 3 states

**Bit 3—Burst Cycle Select 0 (BRSTS0):** Selects the number of words that can be accessed in a burst ROM interface burst access.

Bit 3 BRSTS0	Description
0	Max. 4 words in burst access (burst access on match of address bits above A3) (Initial value)
1	Max. 8 words in burst access (burst access on match of address bits above A4)

**Bit 2—Reserved:** Read-only bit, always read as 1.

**Bit 1—Area Division Unit Select (RDEA):** Selects the memory map area division units. This bit is valid in modes 3, 4, and 5, and is invalid in modes 1, 2, 6, and 7.

Bit 1 RDEA	Description								
0	Area divisions are as follows: <table style="margin-left: 40px; border: none;"> <tr> <td>Area 0: 2 MB</td> <td>Area 4: 1.93 MB</td> </tr> <tr> <td>Area 1: 2 MB</td> <td>Area 5: 4 kB</td> </tr> <tr> <td>Area 2: 8 MB</td> <td>Area 6: 23.75 kB</td> </tr> <tr> <td>Area 3: 2 MB</td> <td>Area 7: 22 B</td> </tr> </table>	Area 0: 2 MB	Area 4: 1.93 MB	Area 1: 2 MB	Area 5: 4 kB	Area 2: 8 MB	Area 6: 23.75 kB	Area 3: 2 MB	Area 7: 22 B
Area 0: 2 MB	Area 4: 1.93 MB								
Area 1: 2 MB	Area 5: 4 kB								
Area 2: 8 MB	Area 6: 23.75 kB								
Area 3: 2 MB	Area 7: 22 B								
1	Areas 0 to 7 are the same size (2 MB) (Initial value)								

**Bit 0—WAIT Pin Enable (WAITE):** Enables or disables wait insertion by means of the  $\overline{\text{WAIT}}$  pin.

Bit 0 WAITE	Description
0	$\overline{\text{WAIT}}$ pin wait input is disabled, and the $\overline{\text{WAIT}}$ pin can be used as an input/output port (Initial value)
1	$\overline{\text{WAIT}}$ pin wait input is enabled

### 6.2.6 Chip Select Control Register (CSCR)

CSCR is an 8-bit readable/writable register that enables or disables output of chip select signals ( $\overline{\text{CS}}_7$  to  $\overline{\text{CS}}_4$ ).

If output of a chip select signal is enabled by a setting in this register, the corresponding pin functions as a chip select signal ( $\overline{\text{CS}}_7$  to  $\overline{\text{CS}}_4$ ) output regardless of any other settings. CSCR cannot be modified in single-chip mode.

Bit	7	6	5	4	3	2	1	0
	CS7E	CS6E	CS5E	CS4E	—	—	—	—
Initial value	0	0	0	0	1	1	1	1
Read/Write :	R/W	R/W	R/W	R/W	—	—	—	—

**Chip select 7 to 4 enable**  
These bits enable or disable chip select signal output
Reserved bits

CSCR is initialized to H'0F by a reset and in hardware standby mode. It is not initialized in software standby mode.

**Bits 7 to 4—Chip Select 7 to 4 Enable (CS7E to CS4E):** These bits enable or disable output of the corresponding chip select signal.

**Bit n**

CSnE	Description
0	Output of chip select signal $\overline{CSn}$ is disabled (Initial value)
1	Output of chip select signal $\overline{CSn}$ is enabled

Note: n = 7 to 4

**Bits 3 to 0—Reserved:** These bits cannot be modified and are always read as 1.

## 6.2.7 DRAM Control Register A (DRCRA)

Bit	7	6	5	4	3	2	1	0
	DRAS2	DRAS1	DRAS0	—	BE	RDM	SRFMD	RFSHE
Initial value	0	0	0	1	0	0	0	0
Read/Write	R/W	R/W	R/W	—	R/W	R/W	R/W	R/W

DRCRA is an 8-bit readable/writable register that selects the areas that have a DRAM interface function, and the access mode, and enables or disables self-refreshing and refresh pin output.

DRCRA is initialized to H'10 by a reset and in hardware standby mode. It is not initialized in software standby mode.

**Bits 7 to 5—DRAM Area Select (DRAS2 to DRAS0):** These bits select which of areas 2 to 5 are to function as DRAM interface areas (DRAM space) in expanded mode, and at the same time select the  $\overline{RAS}$  output pin corresponding to each DRAM space.

**Description**

Bit 7 DRAS2	Bit 6 DRAS1	Bit 5 DRAS0	Area 5	Area 4	Area 3	Area 2
0	0	0	Normal	Normal	Normal	Normal
		1	Normal	Normal	Normal	DRAM space ( $\overline{CS}_2$ )
	1	0	Normal	Normal	DRAM space ( $\overline{CS}_3$ )	DRAM space ( $\overline{CS}_2$ )
1	0	0	Normal	DRAM space ( $\overline{CS}_4$ )	DRAM space ( $\overline{CS}_3$ )	DRAM space ( $\overline{CS}_2$ )
		1	DRAM space ( $\overline{CS}_5$ )	DRAM space ( $\overline{CS}_4$ )	DRAM space ( $\overline{CS}_3$ )	DRAM space ( $\overline{CS}_2$ )
	1	0	DRAM space ( $\overline{CS}_4$ )*		DRAM space ( $\overline{CS}_2$ )*	
		1	DRAM space ( $\overline{CS}_2$ )*			

Note: A single  $\overline{CS}_n$  pin serves as a common  $\overline{RAS}$  output pin for a number of areas. Unused  $\overline{CS}_n$  pins can be used as input/output ports.

When any of bits DRAS2 to DRAS0 is set to 1 in expanded mode, it is not possible to write to DRCRB, RTMCSR, RTCNT, or RTCOR. However, 0 can be written to the CMF flag in RTMCSR to clear the flag.

When an arbitrary value has been set in DRAS2 to DRAS0, a write of a different value other than 000 must not be performed.

**Bit 4—Reserved:** This bit cannot be modified and is always read as 1.

**Bit 3—Burst Access Enable (BE):** Enables or disables burst access to DRAM space. DRAM space burst access is performed in fast page mode.

**Bit 3**

BE	Description
0	Burst disabled (always full access) <span style="float: right;">(Initial value)</span>
1	DRAM space access performed in fast page mode

**Bit 2—RAS Down Mode (RDM):** Selects whether to wait for the next DRAM access with the  $\overline{RAS}$  signal held low (RAS down mode), or to drive the RAS signal high again (RAS up mode), when burst access is enabled for DRAM space (BE = 1), and access to DRAM is interrupted.

Caution is required when the  $\overline{HWR}$  and  $\overline{LWR}$  are used as the  $\overline{UCAS}$  and  $\overline{LCAS}$  output pins. For details, see RAS Down Mode and RAS Up Mode in section 6.5.10, Burst Operation.

Bit 2 RDM	Description	
0	DRAM interface: RAS up mode selected	(Initial value)
1	DRAM interface: RAS down mode selected	

**Bit 1—Self-Refresh Mode (SRFMD):** Specifies DRAM self-refreshing in software standby mode.

When any of areas 2 to 5 is designated as DRAM space, DRAM self-refreshing is possible when a transition is made to software standby mode after the SRFMD bit has been set to 1.

The normal access state is restored when software standby mode is exited, regardless of the SRFMD setting.

Bit 1 SRFMD	Description	
0	DRAM self-refreshing disabled in software standby mode	(Initial value)
1	DRAM self-refreshing enabled in software standby mode	

**Bit 0—Refresh Pin Enable (RFSHE):** Enables or disables  $\overline{\text{RFSH}}$  pin refresh signal output. If areas 2 to 5 are not designated as DRAM space, this bit should not be set to 1.

Bit 0 RFSHE	Description	
0	$\overline{\text{RFSH}}$ pin refresh signal output disabled ( $\overline{\text{RFSH}}$ pin can be used as input/output port)	(Initial value)
1	$\overline{\text{RFSH}}$ pin refresh signal output enabled	

## 6.2.8 DRAM Control Register B (DRCRB)

Bit	7	6	5	4	3	2	1	0
	MXC1	MXC0	CSEL	RCYCE	—	TPC	RCW	RLW
Initial value	0	0	0	0	1	0	0	0
Read/Write	R/W	R/W	R/W	R/W	—	R/W	R/W	R/W

DRCRB is an 8-bit readable/writable register that selects the number of address multiplex column address bits for the DRAM interface, the column address strobe output pin, enabling or disabling of refresh cycle insertion, the number of precharge cycles, enabling or disabling of wait state insertion between  $\overline{\text{RAS}}$  and  $\overline{\text{CAS}}$ , and enabling or disabling of wait state insertion in refresh cycles.

DRCRB is initialized to H'08 by a reset and in hardware standby mode. It is not initialized in software standby mode.

The settings in this register are invalid when bits DRAS2 to DRAS0 in DRCRA are all 0.

**Bits 7 and 6—Multiplex Control 1 and 0 (MXC1, MXC0):** These bits select the row address/column address multiplexing method used on the DRAM interface. In burst operation, the row address used for comparison is determined by the setting of these bits and the bus width of the relevant area set in ABWCR.

Bit 7 MXC1	Bit 6 MXC0	Description	
0	0	Column address: 8 bits	
		Compared address:	
		Modes 1, 2	8-bit access space      A <sub>19</sub> to A <sub>8</sub>
			16-bit access space      A <sub>19</sub> to A <sub>9</sub>
	Modes 3, 4, 5	8-bit access space      A <sub>23</sub> to A <sub>8</sub>	
		16-bit access space      A <sub>23</sub> to A <sub>9</sub>	
		1	Column address: 9 bits
			Compared address:
Modes 1, 2	8-bit access space      A <sub>19</sub> to A <sub>9</sub>		
	16-bit access space      A <sub>19</sub> to A <sub>10</sub>		
Modes 3, 4, 5	8-bit access space      A <sub>23</sub> to A <sub>9</sub>		
	16-bit access space      A <sub>23</sub> to A <sub>10</sub>		
	1	0	Column address: 10 bits
			Compared address:
Modes 1, 2			8-bit access space      A <sub>19</sub> to A <sub>10</sub>
			16-bit access space      A <sub>19</sub> to A <sub>11</sub>
Modes 3, 4, 5		8-bit access space      A <sub>23</sub> to A <sub>10</sub>	
		16-bit access space      A <sub>23</sub> to A <sub>11</sub>	
		1	Illegal setting

**Bit 5—CAS Output Pin Select (CSEL):** Selects the  $\overline{UCAS}$  and  $\overline{LCAS}$  output pins when areas 2 to 5 are designated as DRAM space.

Bit 5 CSEL	Description
0	PB4 and PB5 selected as $\overline{UCAS}$ and $\overline{LCAS}$ output pins (Initial value)
1	HWR and LWR selected as $\overline{UCAS}$ and $\overline{LCAS}$ output pins



**Bit 4—Refresh Cycle Enable (RCYCE):** Enables or disables CAS-before-RAS refresh cycle insertion. When none of areas 2 to 5 has been designated as DRAM space, refresh cycles are not inserted regardless of the setting of this bit.

**Bit 4**

RCYCE	Description	
0	Refresh cycles disabled	(Initial value)
1	DRAM refresh cycles enabled	

**Bit 3—Reserved:** This bit cannot be modified and is always read as 1.

**Bit 2—TP Cycle Control (TPC):** Selects whether a 1-state or two-state precharge cycle (TP) is to be used for DRAM read/write cycles and CAS-before-RAS refresh cycles.

The setting of this bit does not affect the self-refresh function.

**Bit 2**

TPC	Description	
0	1-state precharge cycle inserted	(Initial value)
1	2-state precharge cycle inserted	

**Bit 1— $\overline{\text{RAS}}\text{-}\overline{\text{CAS}}$  Wait (RCW):** Controls wait state ( $T_{rw}$ ) insertion between  $T_r$  and  $T_{c1}$  in DRAM read/write cycles. The setting of this bit does not affect refresh cycles.

**Bit 1**

RCW	Description	
0	Wait state ( $T_{rw}$ ) insertion disabled	(Initial value)
1	One wait state ( $T_{rw}$ ) inserted	

**Bit 0—Refresh Cycle Wait Control (RLW):** Controls wait state ( $T_{RW}$ ) insertion for CAS-before-RAS refresh cycles. The setting of this bit does not affect DRAM read/write cycles.

**Bit 0**

RLW	Description	
0	Wait state ( $T_{RW}$ ) insertion disabled	(Initial value)
1	One wait state ( $T_{RW}$ ) inserted	

## 6.2.9 Refresh Timer Control/Status Register (RTMCSR)

Bit	7	6	5	4	3	2	1	0
	CMF	CMIE	CKS2	CKS1	CKS0	—	—	—
Initial value	0	0	0	0	0	1	1	1
Read/Write	R(W)*	R/W	R/W	R/W	R/W	—	—	—

RTMCSR is an 8-bit readable/writable register that selects the refresh timer counter clock. When the refresh timer is used as an interval timer, RTMCSR also enables or disables interrupt requests. Bits 7 and 6 of RTMCSR are initialized to 0 by a reset and in the standby modes. Bits 5 to 3 are initialized to 0 by a reset and in hardware standby mode; they are not initialized in software standby mode.

Note: Only 0 can be written to clear the flag.

**Bit 7—Compare Match Flag (CMF):** Status flag that indicates a match between the values of RTCNT and RTCOR.

### Bit 7 CMF

#### Description

0	Clearing conditions When the chip is reset and in standby mode Read CMF when CMF = 1, then write 0 in CMF	(Initial value)
1	Setting condition When RTCNT = RTCOR	

**Bit 6—Compare Match Interrupt Enable (CMIE):** Enables or disables the CMI interrupt requested when the CMF flag is set to 1 in RTMCSR. The CMIE bit is always cleared to 0 when any of areas 2 to 5 is designated as DRAM space.

### Bit 6 CMIE

#### Description

0	The CMI interrupt requested by CMF is disabled	(Initial value)
1	The CMI interrupt requested by CMF is enabled	

**Bits 5 to 3—Refresh Counter Clock Select (CKS2 to CKS0):** These bits select the clock to be input to RTCNT from among 7 clocks obtained by dividing the system clock ( $\phi$ ). When the input clock is selected with bits CKS2 to CKS0, RTCNT begins counting up.

Bit 5 CKS2	Bit 4 CKS1	Bit 3 CKS0	Description
0	0	0	Count operation halted (Initial value)
		1	$\phi/2$ used as counter clock
1	0	0	$\phi/8$ used as counter clock
		1	$\phi/32$ used as counter clock
1	0	0	$\phi/128$ used as counter clock
		1	$\phi/512$ used as counter clock
1	1	0	$\phi/2048$ used as counter clock
		1	$\phi/4096$ used as counter clock

**Bits 2 to 0—Reserved:** These bits cannot be modified and are always read as 1.

### 6.2.10 Refresh Timer Counter (RTCNT)

Bit	7	6	5	4	3	2	1	0
Initial value	0	0	0	0	0	0	0	0
Read/Write	R/W	R/W	R/W	R/W	R/W	R/W	R/W	R/W

RTCNT is an 8-bit readable/writable up-counter.

RTCNT is incremented by an internal clock selected by bits CKS2 to CKS0 in RTMCSR. When RTCNT matches RTCOR (compare match), the CMF flag in RTMCSR is set to 1 and RTCNT is cleared to H'00. If the RCYCE bit in DRCRB is set to 1 at this time, a refresh cycle is started. Also, if the CMIE bit in RTMCSR is set to 1, a compare match interrupt (CMI) is generated.

RTCNT is initialized to H'00 by a reset and in standby mode.

### 6.2.11 Refresh Time Constant Register (RTCOR)

Bit	7	6	5	4	3	2	1	0
Initial value	1	1	1	1	1	1	1	1
Read/Write	R/W	R/W	R/W	R/W	R/W	R/W	R/W	R/W

RTCOR is an 8-bit readable/writable register that determines the interval at which RTCNT is cleared.

RTCOR and RTCNT are constantly compared. When their values match, the CMF flag is set to 1 in RTMCSR, and RTCNT is simultaneously cleared to H'00.

RTCOR is initialized to H'FF by a reset and in hardware standby mode. It is not initialized in software standby mode.

Note: Only byte access can be used on this register.

## 6.2.12 Address Control Register (ADRCR) (Provided Only in Flash Memory R Version and Mask ROM Versions)

ADRCR is an 8-bit readable/writable register that selects either address update mode 1 or address update mode 2 as the address output method.

Bit	:	7	6	5	4	3	2	1	0
		—	—	—	—	—	—	—	ADRCTL
Initial value	:	1	1	1	1	1	1	1	1
R/W	:	—	—	—	—	—	—	—	R/W
		Reserved bits						Address control	
								Selects address update mode 1 or address update mode 2	

ADRCR is initialized to H'FF by a reset and in hardware standby mode. It is not initialized in software standby mode.

**Bits 7 to 1—Reserved:** Read-only bits, always read as 1.

**Bit 0—Address Control (ADRCTL):** Selects the address output method.

### Bit 0

#### ADRCTL

#### Description

ADRCTL	Description
0	Address update mode 2 is selected
1	Address update mode 1 is selected (Initial value)

This register is provided only in the flash memory R version and mask ROM versions; it is not present in the flash memory version (HD64F3067). If this space is accessed in the flash memory version (HD64F3067), a write access will be invalid and a read access will return H'FF.

## 6.3 Operation

### 6.3.1 Area Division

The external address space is divided into areas 0 to 7. Each area has a size of 128 kbytes in the 1-Mbyte modes, or 2-Mbytes in the 16-Mbyte modes. Figure 6.2 shows a general view of the memory map.

H' 00000	Area 0 (128 kbytes)	H' 000000	Area 0 (2 Mbytes)
H' 1FFFF		H' 1FFFFFF	
H' 20000	Area 1 (128 kbytes)	H' 200000	Area 1 (2 Mbytes)
H' 3FFFF		H' 3FFFFFF	
H' 40000	Area 2 (128 kbytes)	H' 400000	Area 2 (2 Mbytes)
H' 5FFFF		H' 5FFFFFF	
H' 60000	Area 3 (128 kbytes)	H' 600000	Area 3 (2 Mbytes)
H' 7FFFF		H' 7FFFFFF	
H' 80000	Area 4 (128 kbytes)	H' 800000	Area 4 (2 Mbytes)
H' 9FFFF		H' 9FFFFFF	
H' A0000	Area 5 (128 kbytes)	H' A00000	Area 5 (2 Mbytes)
H' BFFFF		H' BFFFFFF	
H' C0000	Area 6 (128 kbytes)	H' C00000	Area 6 (2 Mbytes)
H' DFFFF		H' DFFFFFF	
H' E0000	Area 7 (128 Mbytes)	H' E00000	Area 7 (2 Mbytes)
H' FFFFF		H' FFFFFFF	

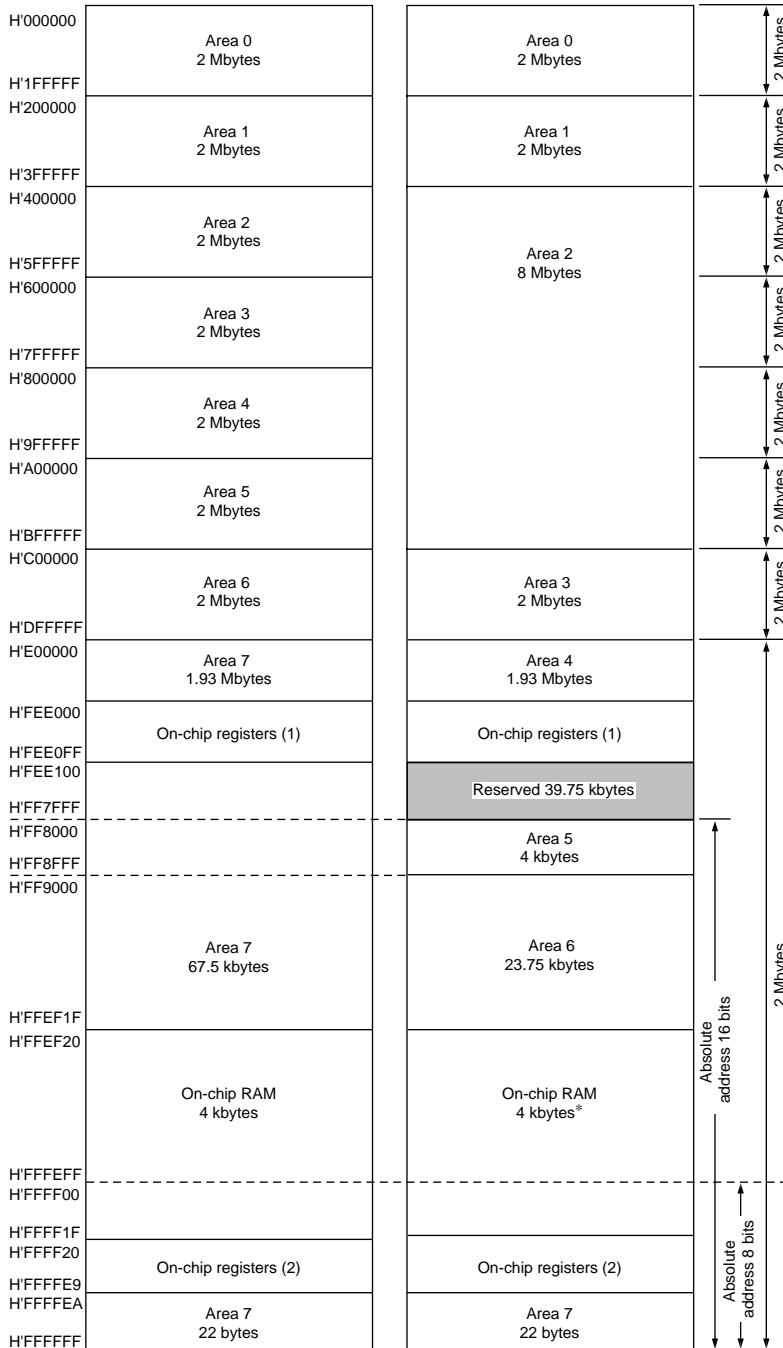
(a) 1-Mbyte modes (modes 1, and 2)

(b) 16-Mbyte modes (modes 3, 4, and 5)

**Figure 6.2 Access Area Map for Each Operating Mode**

Chip select signals ( $\overline{\text{CS}}_0$  to  $\overline{\text{CS}}_7$ ) can be output for areas 0 to 7. The bus specifications for each area are selected in ABWCR, ASTCR, WCRH, and WCRL.

In 16-Mbyte mode, the area division units can be selected with the RDEA bit in BCR.



(A) Memory map when RDEA = 1

(b) Memory map when RDEA = 0

Note: \* Area 6 when the RAME bit is cleared.

**Figure 6.3 Memory Map in 16-Mbyte Mode (H8/3067, H8/3066)**



### 6.3.2 Bus Specifications

The external space bus specifications consist of three elements: (1) bus width, (2) number of access states, and (3) number of program wait states.

The bus width and number of access states for on-chip memory and registers are fixed, and are not affected by the bus controller.

**Bus Width:** A bus width of 8 or 16 bits can be selected with ABWCR. An area for which an 8-bit bus is selected functions as an 8-bit access space, and an area for which a 16-bit bus is selected functions as a 16-bit access space.

If all areas are designated for 8-bit access, 8-bit bus mode is set; if any area is designated for 16-bit access, 16-bit bus mode is set.

**Number of Access States:** Two or three access states can be selected with ASTCR. An area for which two-state access is selected functions as a two-state access space, and an area for which three-state access is selected functions as a three-state access space.

DRAM space is accessed in four states regardless of the ASTCR settings.

When two-state access space is designated, wait insertion is disabled.

**Number of Program Wait States:** When three-state access space is designated in ASTCR, the number of program wait states to be inserted automatically is selected with WCRH and WCRL. From 0 to 3 program wait states can be selected.

When ASTCR is cleared to 0 for DRAM space, a program wait ( $T_{c1}$ - $T_{c2}$  wait) is not inserted. Also, no program wait is inserted in burst ROM space burst cycles.

Table 6.3 shows the bus specifications for each basic bus interface area.

**Table 6.3 Bus Specifications for Each Area (Basic Bus Interface)**

ABWCR	ASTCR	WCRH/WCRL		Bus Specifications (Basic Bus Interface)		
ABWn	ASTn	Wn1	Wn0	Bus Width	Access States	Program Wait States
0	0	—	—	16	2	0
	1	0	0		3	0
			1		1	
			0		2	
			1		3	
1	0	—	—	8	2	0
	1	0	0		3	0
			1		1	
			0		2	
			1		3	

Note: n = 7 to 0

### 6.3.3 Memory Interfaces

The H8/3067 Series memory interfaces comprise a basic bus interface that allows direct connection of ROM, SRAM, and so on; a DRAM interface that allows direct connection of DRAM; and a burst ROM interface that allows direct connection of burst ROM. The interface can be selected independently for each area.

An area for which the basic bus interface is designated functions as normal space, an area for which the DRAM interface is designated functions as DRAM space, and area 0 for which the burst ROM interface is designated functions as burst ROM space.

### 6.3.4 Chip Select Signals

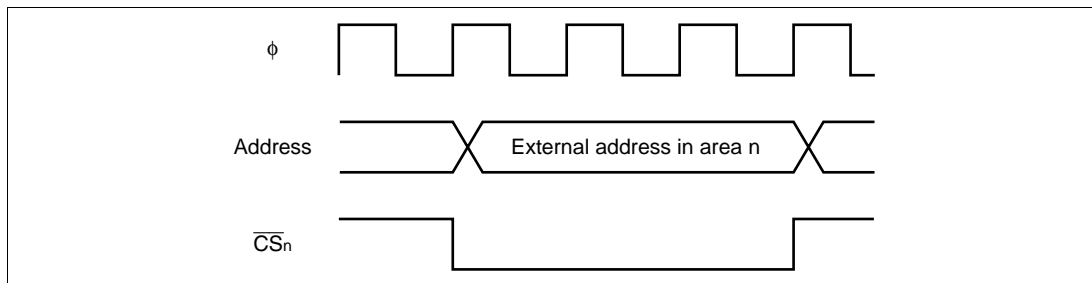
For each of areas 0 to 7, the H8/3067 Series can output a chip select signal ( $\overline{CS}_0$  to  $\overline{CS}_7$ ) that goes low when the corresponding area is selected in expanded mode. Figure 6.4 shows the output timing of a  $\overline{CS}_n$  signal.

**Output of  $\overline{CS}_0$  to  $\overline{CS}_3$ :** Output of  $\overline{CS}_0$  to  $\overline{CS}_3$  is enabled or disabled in the data direction register (DDR) of the corresponding port.

In the expanded modes with on-chip ROM disabled, a reset leaves pin  $\overline{CS}_0$  in the output state and pins  $\overline{CS}_1$  to  $\overline{CS}_3$  in the input state. To output chip select signals  $\overline{CS}_1$  to  $\overline{CS}_3$ , the corresponding DDR bits must be set to 1. In the expanded modes with on-chip ROM enabled, a reset leaves pins

$\overline{CS}_0$  to  $\overline{CS}_3$  in the input state. To output chip select signals  $\overline{CS}_0$  to  $\overline{CS}_3$ , the corresponding DDR bits must be set to 1. For details, see section 8, I/O Ports.

**Output of  $\overline{CS}_4$  to  $\overline{CS}_7$ :** Output of  $\overline{CS}_4$  to  $\overline{CS}_7$  is enabled or disabled in the chip select control register (CSCR). A reset leaves pins  $\overline{CS}_4$  to  $\overline{CS}_7$  in the input state. To output chip select signals  $\overline{CS}_4$  to  $\overline{CS}_7$ , the corresponding CSCR bits must be set to 1. For details, see section 8, I/O Ports.



**Figure 6.4  $\overline{CS}_n$  Signal Output Timing (n = 0 to 7)**

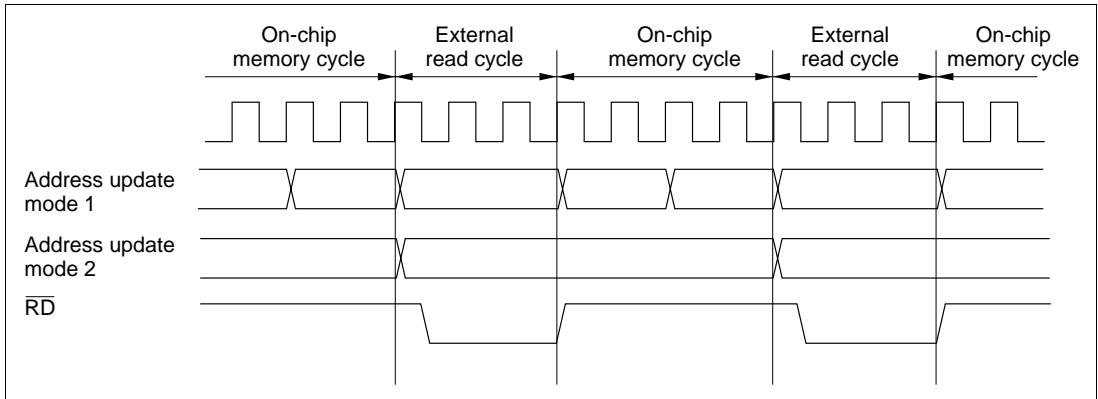
When the on-chip ROM, on-chip RAM, and on-chip registers are accessed,  $\overline{CS}_0$  to  $\overline{CS}_7$  remain high. The  $\overline{CS}_n$  signals are decoded from the address signals. They can be used as chip select signals for SRAM and other devices.

### 6.3.5 Address Output Method

#### (Function Provided Only in Flash Memory R Version and Mask ROM Versions)

The H8/3067 Series provides a choice of two address update methods: either the same method as in the previous H8/300H Series (address update mode 1), or a method in which address update is restricted to external space accesses or self-refresh cycles (address update mode 2).

Figure 6.5 shows examples of address output in these two update modes.



**Figure 6.5 Sample Address Output in Each Address Update Mode  
(Basic Bus Interface, 3-State Space)**

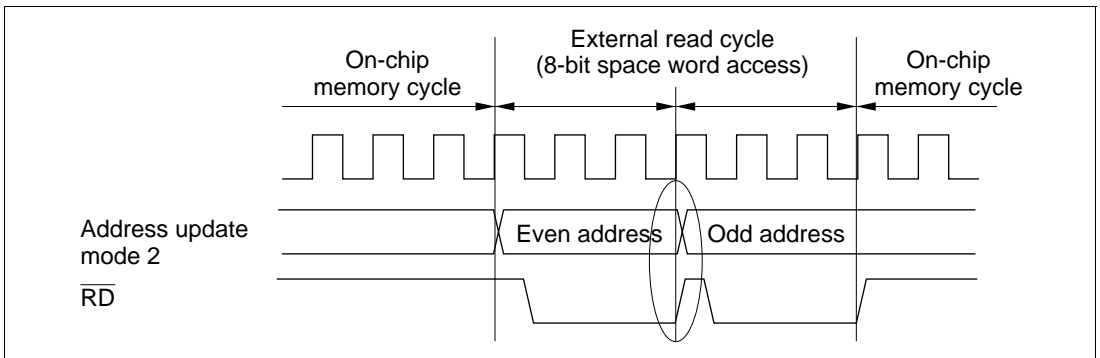
**Address Update Mode 1:** Address update mode 1 is compatible with the previous H8/300H Series. Addresses are always updated between bus cycles.

**Address Update Mode 2:** In address update mode 2, address updating is performed only in external space accesses or self-refresh cycles. In this mode, the address can be retained between an external space read cycle and an instruction fetch cycle (on-chip memory) by placing the program in on-chip memory. Address update mode 2 is therefore useful when connecting a device that requires address hold time with respect to the rise of the  $\overline{RD}$  strobe.

Switching between address update modes 1 and 2 is performed by means of the  $ADRCTL$  bit in  $ADRCR$ . The initial value of  $ADRCR$  is the address update mode 1 setting, providing compatibility with the previous H8/300H Series.

**Cautions:** The address output methods are designed so that the initial state with the bit selection method is compatible with the flash memory version (HD64F3067) (i.e. address update mode 1), and so there is basically no problem if this version is replaced with the flash memory R version or a mask ROM version. However, the following points should be noted.

- ADRCR is allocated to address H'FEE01E. In the flash memory version, the corresponding address is empty space, but it is necessary to confirm that no accesses are made to H'FEE01E in the program.
- When address update mode 2 is selected, the address in an internal space (on-chip memory or internal I/O) access cycle is not output externally.
- In order to secure address holding with respect to the rise of  $\overline{RD}$ , when address update mode 2 is used an external space read access must be completed within a single access cycle. For example, in a word access to 8-bit access space, the bus cycle is split into two as shown in figure 6.6., and so there is not a single access cycle. In this case, address holding is not guaranteed at the rise of  $\overline{RD}$  between the first (even address) and second (odd address) access cycles (area inside the ellipse in the figure).



**Figure 6.6 Example of Consecutive External Space Accesses in Address Update Mode 2**

- When address update mode 2 is selected, in a DRAM space CAS-before-RAS (CBR) refresh cycle the previous address is retained (the area 2 start address is not output).

## 6.4 Basic Bus Interface

### 6.4.1 Overview

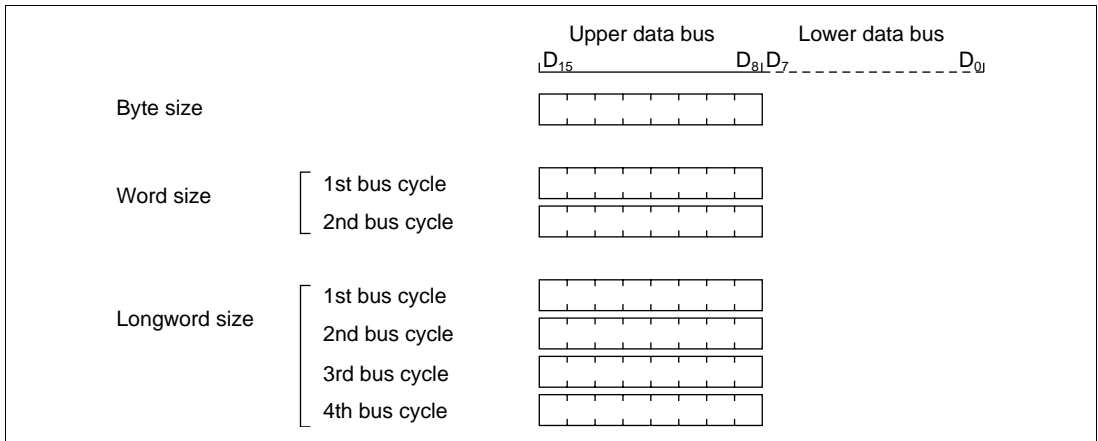
The basic bus interface enables direct connection of ROM, SRAM, and so on.

The bus specifications can be selected with ABWCR, ASTCR, WCRH, and WCRL (see table 6.3).

### 6.4.2 Data Size and Data Alignment

Data sizes for the CPU and other internal bus masters are byte, word, and longword. The bus controller has a data alignment function, and when accessing external space, controls whether the upper data bus ( $D_{15}$  to  $D_8$ ) or lower data bus ( $D_7$  to  $D_0$ ) is used according to the bus specifications for the area being accessed (8-bit access area or 16-bit access area) and the data size.

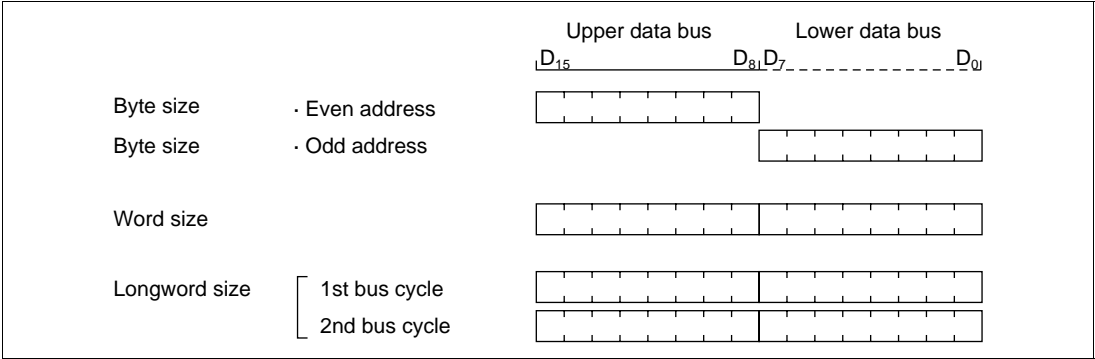
**8-Bit Access Areas:** Figure 6.7 illustrates data alignment control for 8-bit access space. With 8-bit access space, the upper data bus ( $D_{15}$  to  $D_8$ ) is always used for accesses. The amount of data that can be accessed at one time is one byte: a word access is performed as two byte accesses, and a longword access, as four byte accesses.



**Figure 6.7 Access Sizes and Data Alignment Control (8-Bit Access Area)**

**16-Bit Access Areas:** Figure 6.8 illustrates data alignment control for 16-bit access areas. With 16-bit access areas, the upper data bus ( $D_{15}$  to  $D_8$ ) and lower data bus ( $D_7$  to  $D_0$ ) are used for accesses. The amount of data that can be accessed at one time is one byte or one word, and a longword access is executed as two word accesses.

In byte access, whether the upper or lower data bus is used is determined by whether the address is even or odd. The upper data bus is used for an even address, and the lower data bus for an odd address.



**Figure 6.8 Access Sizes and Data Alignment Control (16-Bit Access Area)**

**6.4.3 Valid Strobes**

Table 6.4 shows the data buses used, and the valid strobes, for the access spaces.

In a read, the  $\overline{RD}$  signal is valid for both the upper and the lower half of the data bus.

In a write, the  $\overline{HWR}$  signal is valid for the upper half of the data bus, and the  $\overline{LWR}$  signal for the lower half.

**Table 6.4 Data Buses Used and Valid Strobes**

Area	Access Size	Read/Write	Address	Valid Strobe	Upper Data Bus (D <sub>15</sub> to D <sub>8</sub> )	Lower Data Bus (D <sub>7</sub> to D <sub>0</sub> )
8-bit access area	Byte	Read	—	$\overline{RD}$	Valid	Invalid
		Write	—	$\overline{HWR}$		Undetermined data
16-bit access area	Byte	Read	Even	$\overline{RD}$	Valid	Invalid
			Odd		Invalid	Valid
	Write	Even	$\overline{HWR}$	Valid	Undetermined data	
		Odd	$\overline{LWR}$	Undetermined data	Valid	
Word	Read	—	$\overline{RD}$	Valid	Valid	
	Write	—	$\overline{HWR}, \overline{LWR}$	Valid	Valid	

Notes: 1. Undetermined data means that unpredictable data is output.  
2. Invalid means that the bus is in the input state and the input is ignored.

#### 6.4.4 Memory Areas

The initial state of each area is basic bus interface, three-state access space. The initial bus width is selected according to the operating mode. The bus specifications described here cover basic items only, and the following sections should be referred to for further details: 6.4, Basic Bus Interface, 6.5, DRAM Interface, 6.8, Burst ROM Interface.

**Area 0:** Area 0 includes on-chip ROM, and in ROM-disabled expansion mode, all of area 0 is external space. In ROM-enabled expansion mode, the space excluding on-chip ROM is external space.

When area 0 external space is accessed, the  $\overline{CS}_0$  signal can be output.

Either basic bus interface or burst ROM interface can be selected for area 0.

The size of area 0 is 128 kbytes in modes 1 and 2, and 2 Mbytes in modes 3, 4, and 5.

**Areas 1 and 6:** In external expansion mode, areas 1 and 6 are entirely external space.

When area 1 and 6 external space is accessed, the  $\overline{CS}_1$  and  $\overline{CS}_6$  pin signals respectively can be output.

Only the basic bus interface can be used for areas 1 and 6.

The size of areas 1 and 6 is 128 kbytes in modes 1 and 2, and 2 Mbytes in modes 3, 4, and 5.



**Areas 2 to 5:** In external expansion mode, areas 2 to 5 are entirely external space. When area 2 to 5 external space is accessed, signals  $\overline{CS}_2$  to  $\overline{CS}_5$  can be output. Basic bus interface or DRAM interface can be selected for areas 2 to 5. With the DRAM interface, signals  $\overline{CS}_2$  to  $\overline{CS}_5$  are used as  $\overline{RAS}$  signals. The size of areas 2 to 5 is 128 kbytes in modes 1 and 2, and 2 Mbytes in modes 3, 4, and 5.

**Area 7:** Area 7 includes the on-chip RAM and registers. In external expansion mode, the space excluding the on-chip RAM and registers is external space. The on-chip RAM is enabled when the RAME bit in the system control register (SYSCR) is set to 1; when the RAME bit is cleared to 0, the on-chip RAM is disabled and the corresponding space becomes external space. When area 7 external space is accessed, the  $\overline{CS}_7$  signal can be output. Only the basic bus interface can be used for the area 7 memory interface. The size of area 7 is 128 kbytes in modes 1 and 2, and 2 Mbytes in modes 3, 4, and 5.

## 6.4.5 Basic Bus Control Signal Timing

### 8-Bit, Three-State-Access Areas

Figure 6.9 shows the timing of bus control signals for an 8-bit, three-state-access area. The upper data bus ( $D_{15}$  to  $D_8$ ) is used in accesses to these areas. The  $\overline{LWR}$  pin is always high. Wait states can be inserted.

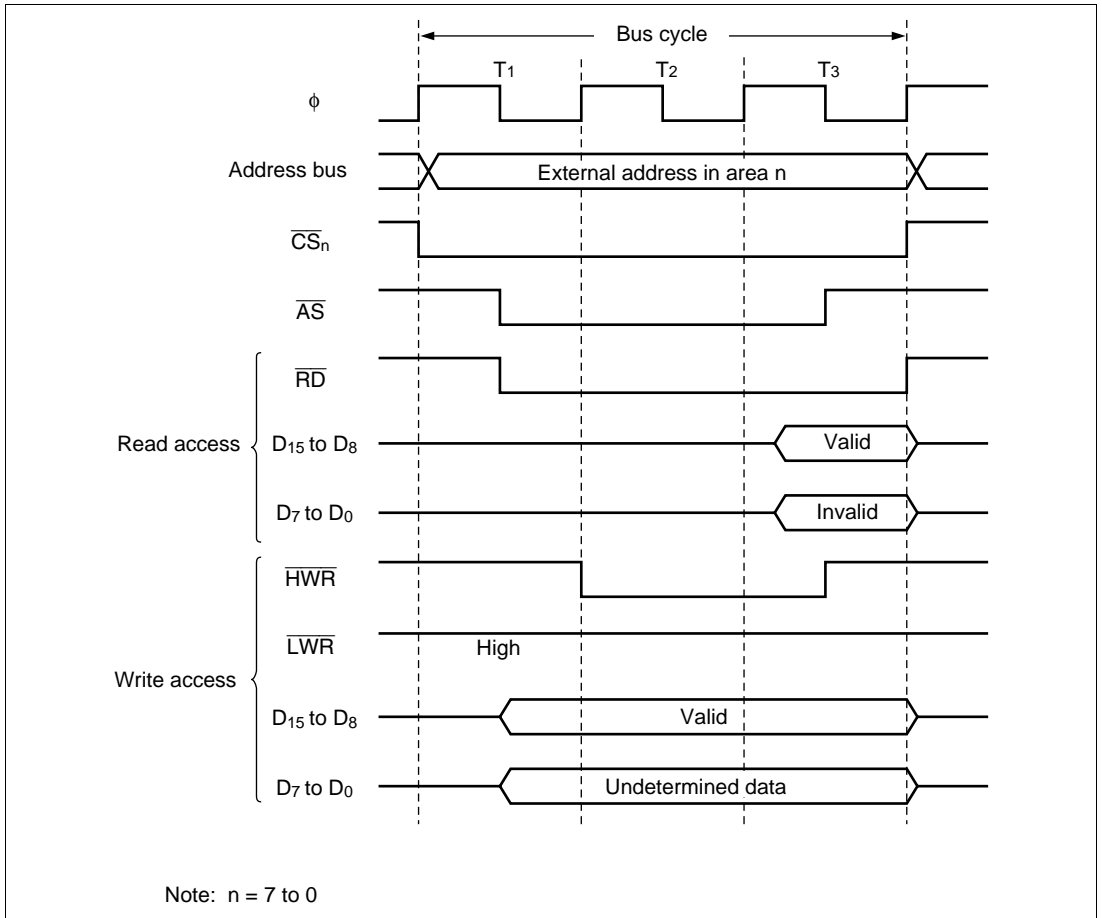


Figure 6.9 Bus Control Signal Timing for 8-Bit, Three-State-Access Area

## 8-Bit, Two-State-Access Areas

Figure 6.10 shows the timing of bus control signals for an 8-bit, two-state-access area. The upper data bus ( $D_{15}$  to  $D_8$ ) is used in accesses to these areas. The  $\overline{LWR}$  pin is always high. Wait states cannot be inserted.

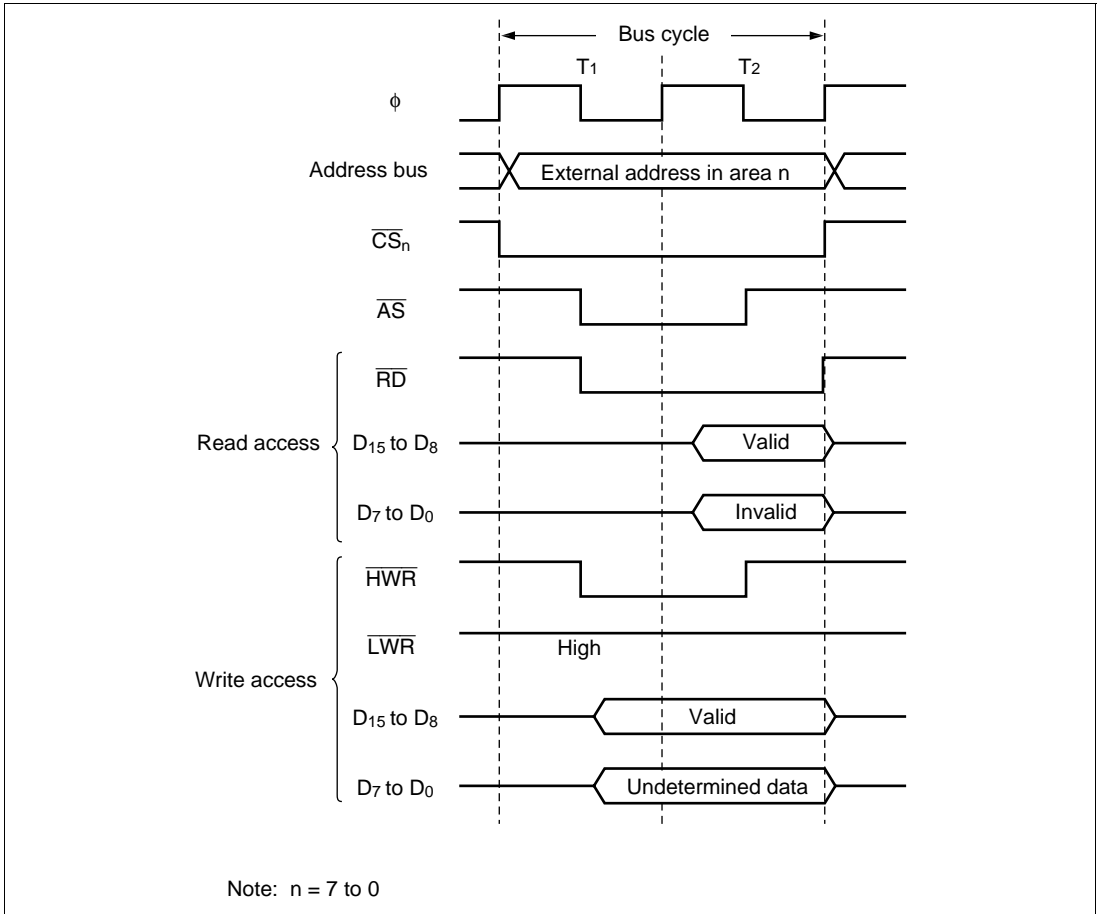
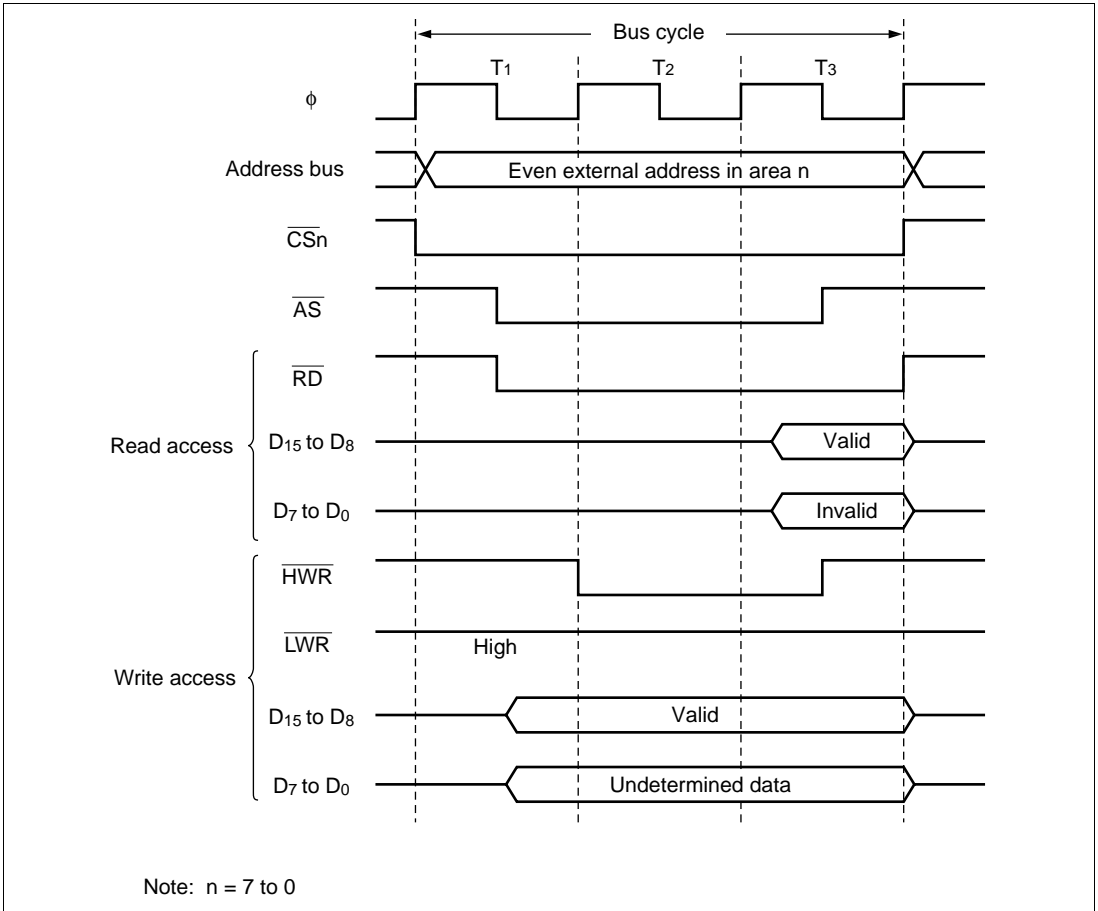


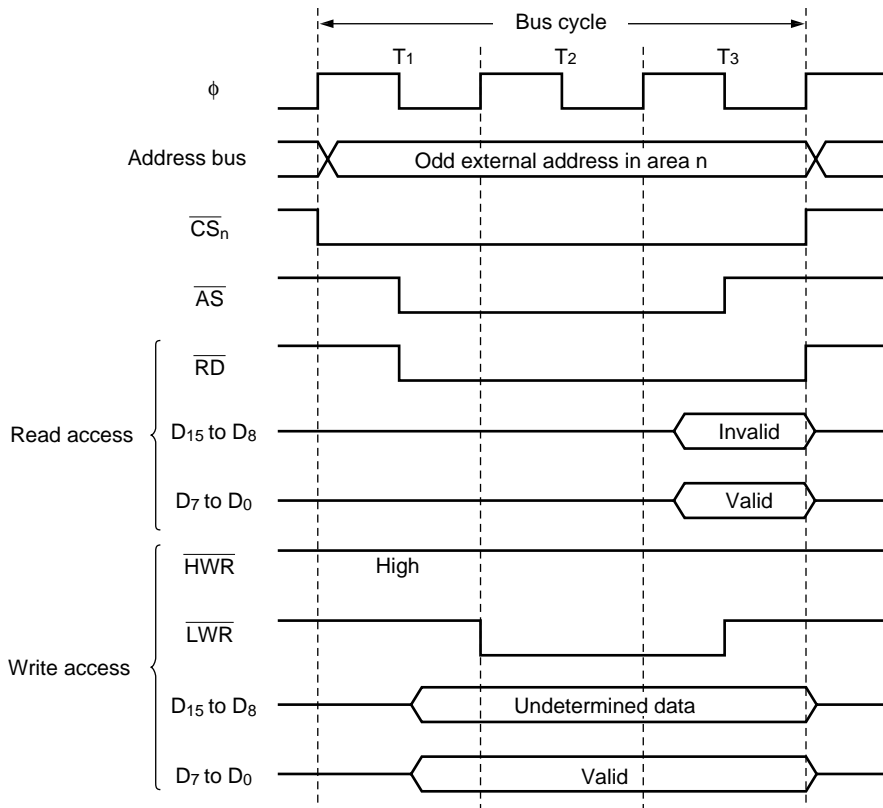
Figure 6.10 Bus Control Signal Timing for 8-Bit, Two-State-Access Area

## 16-Bit, Three-State-Access Areas

Figures 6.11 to 6.13 show the timing of bus control signals for a 16-bit, three-state-access area. In these areas, the upper data bus ( $D_{15}$  to  $D_8$ ) is used in accesses to even addresses and the lower data bus ( $D_7$  to  $D_0$ ) in accesses to odd addresses. Wait states can be inserted.

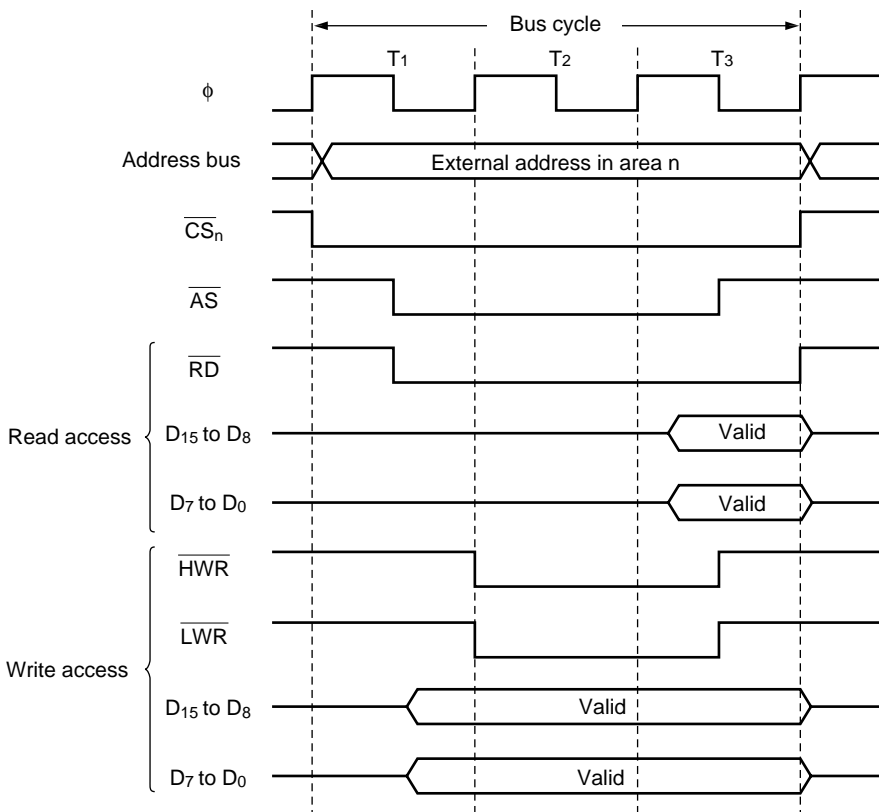


**Figure 6.11 Bus Control Signal Timing for 16-Bit, Three-State-Access Area (1)**  
**(Byte Access to Even Address)**



Note:  $n = 7 \text{ to } 0$

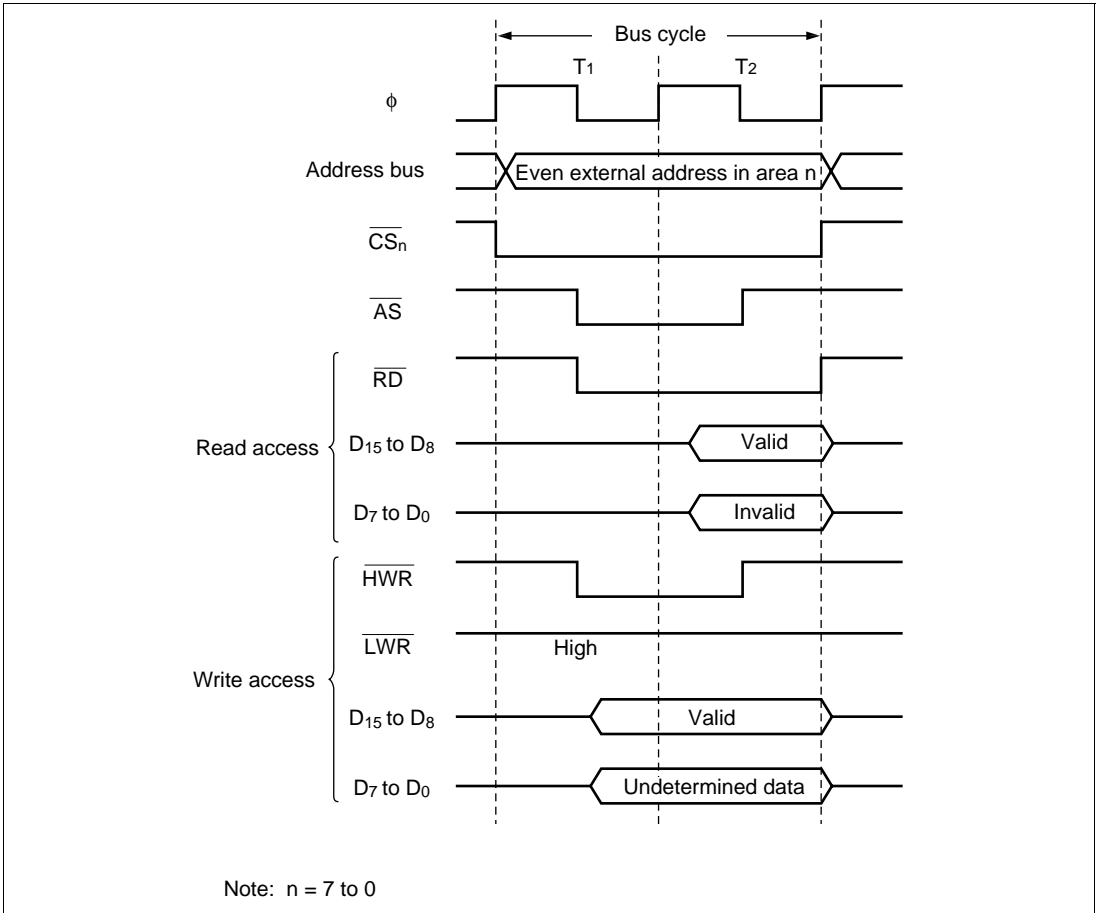
**Figure 6.12 Bus Control Signal Timing for 16-Bit, Three-State-Access Area (2)  
(Byte Access to Odd Address)**



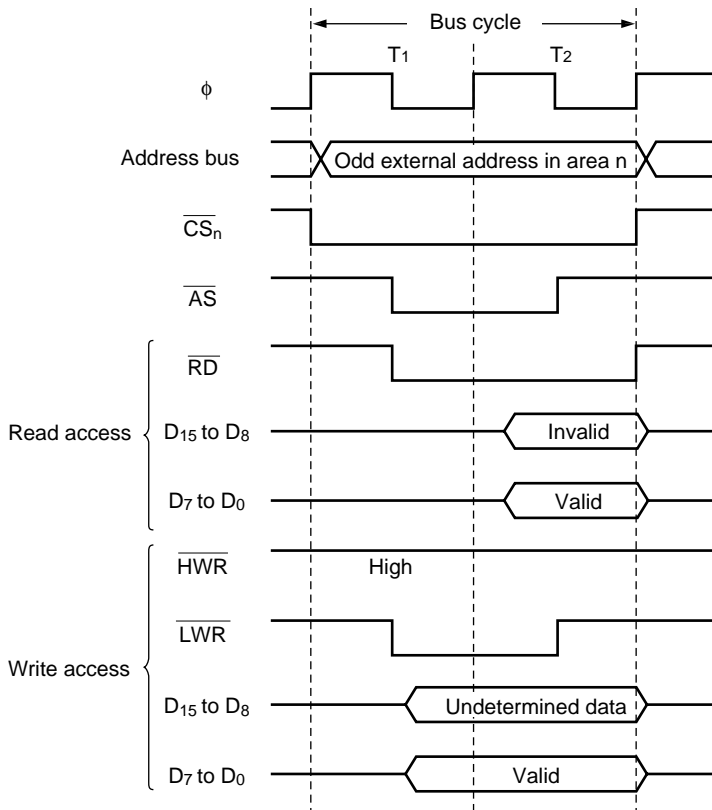
Note: n = 7 to 0

**Figure 6.13 Bus Control Signal Timing for 16-Bit, Three-State-Access Area (3)  
(Word Access)**

**16-Bit, Two-State-Access Areas:** Figures 6.14 to 6.16 show the timing of bus control signals for a 16-bit, two-state-access area. In these areas, the upper data bus ( $D_{15}$  to  $D_8$ ) is used in accesses to even addresses and the lower data bus ( $D_7$  to  $D_0$ ) in accesses to odd addresses. Wait states cannot be inserted.



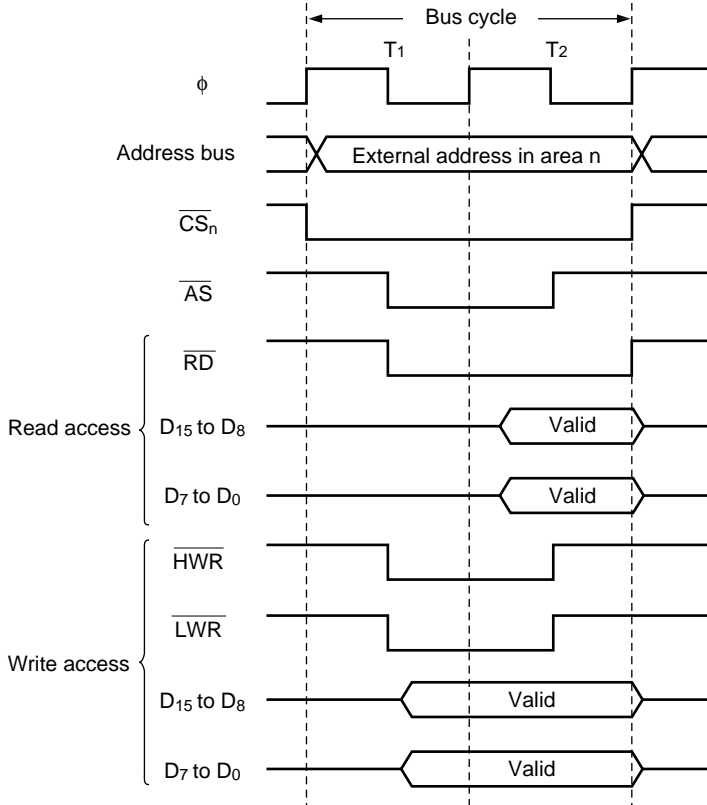
**Figure 6.14 Bus Control Signal Timing for 16-Bit, Two-State-Access Area (1)  
(Byte Access to Even Address)**



Note:  $n = 7$  to  $0$

**Figure 6.15 Bus Control Signal Timing for 16-Bit, Two-State-Access Area (2)  
(Byte Access to Odd Address)**





**Figure 6.16 Bus Control Signal Timing for 16-Bit, Two-State-Access Area (3)  
(Word Access)**

#### 6.4.6 Wait Control

When accessing external space, the H8/3067 Series can extend the bus cycle by inserting one or more wait states ( $T_w$ ). There are two ways of inserting wait states: (1) program wait insertion and (2) pin wait insertion using the  $\overline{\text{WAIT}}$  pin.

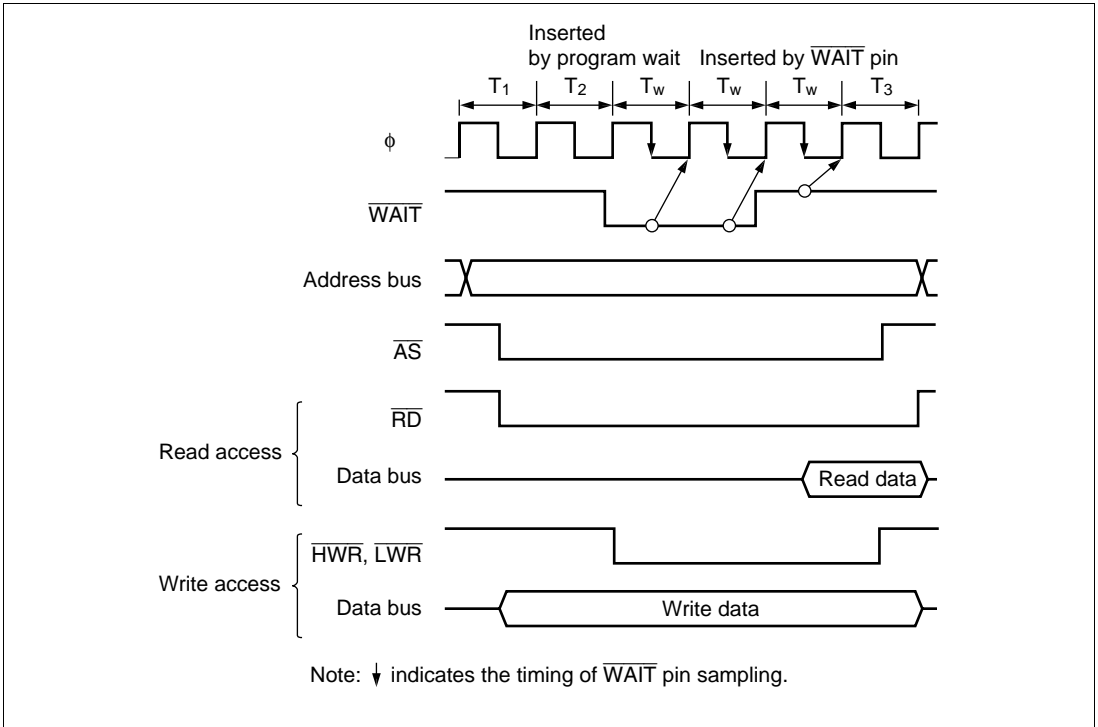
**Program Wait Insertion:** From 0 to 3 wait states can be inserted automatically between the  $T_2$  state and  $T_3$  state on an individual area basis in three-state access space, according to the settings of WCRH and WCRL.

**Pin Wait Insertion:** Setting the WAITE bit in BCR to 1 enables wait insertion by means of the  $\overline{\text{WAIT}}$  pin. When external space is accessed in this state, a program wait is first inserted. If the  $\overline{\text{WAIT}}$  pin is low at the falling edge of  $\phi$  in the last  $T_2$  or  $T_w$  state, another  $T_w$  state is inserted. If the  $\overline{\text{WAIT}}$  pin is held low,  $T_w$  states are inserted until it goes high.

This is useful when inserting four or more  $T_w$  states, or when changing the number of  $T_w$  states for different external devices.

The WAITE bit setting applies to all areas. Pin waits cannot be inserted in DRAM space.

Figure 6.17 shows an example of the timing for insertion of one program wait state in 3-state space.



**Figure 6.17 Example of Wait State Insertion Timing**

## 6.5 DRAM Interface

### 6.5.1 Overview

The H8/3067 Series is provided with a DRAM interface with functions for DRAM control signal ( $\overline{\text{RAS}}$ ,  $\overline{\text{UCAS}}$ ,  $\overline{\text{LCAS}}$ ,  $\overline{\text{WE}}$ ) output, address multiplexing, and refreshing, that direct connection of DRAM. In the expanded modes, external address space areas 2 to 5 can be designated as DRAM space accessed via the DRAM interface. A data bus width of 8 or 16 bits can be selected for DRAM space by means of a setting in ABWCR. When a 16-bit data bus width is selected, CAS is used for byte access control. In the case of  $\times 16$ -bit organization DRAM, therefore, the 2-CAS type can be connected. A fast page mode is supported in addition to the normal read and write access modes.

### 6.5.2 DRAM Space and $\overline{\text{RAS}}$ Output Pin Settings

Designation of areas 2 to 5 as DRAM space, and selection of the  $\overline{\text{RAS}}$  output pin for each area designated as DRAM space, is performed by setting bits in DRCRA. Table 6.5 shows the correspondence between the settings of bits DRAS2 to DRAS0 and the selected DRAM space and  $\overline{\text{RAS}}$  output pin.

When an arbitrary value has been set in DRAS2 to DRAS0, a write of a different value other than 000 must not be performed.

**Table 6.5 Settings of Bits DRAS2 to DRAS0 and Corresponding DRAM Space ( $\overline{\text{RAS}}$  Output Pin)**

DRAS2	DRAS1	DRAS0	Area 5	Area 4	Area 3	Area 2
0	0	0	Normal space	Normal space	Normal space	Normal space
		1	Normal space	Normal space	Normal space	DRAM space ( $\overline{\text{CS}}_2$ )
	1	0	Normal space	Normal space	DRAM space ( $\overline{\text{CS}}_3$ )	DRAM space ( $\overline{\text{CS}}_2$ )
		1	Normal space	Normal space	DRAM space ( $\overline{\text{CS}}_2$ )*	
1	0	0	Normal space	DRAM space ( $\overline{\text{CS}}_4$ )	DRAM space ( $\overline{\text{CS}}_3$ )	DRAM space ( $\overline{\text{CS}}_2$ )
		1	DRAM space ( $\overline{\text{CS}}_5$ )	DRAM space ( $\overline{\text{CS}}_4$ )	DRAM space ( $\overline{\text{CS}}_3$ )	DRAM space ( $\overline{\text{CS}}_2$ )
	1	0	DRAM space ( $\overline{\text{CS}}_4$ )*		DRAM space ( $\overline{\text{CS}}_2$ )*	
		1	DRAM space ( $\overline{\text{CS}}_2$ )*			

Note: \* A single  $\overline{\text{CS}}_n$  pin serves as a common  $\overline{\text{RAS}}$  output pin for a number of areas. Unused  $\overline{\text{CS}}_n$  pins can be used as input/output ports.

### 6.5.3 Address Multiplexing

When DRAM space is accessed, the row address and column address are multiplexed. The address multiplexing method is selected with bits MXC1 and MXC0 in DRCRB according to the number of bits in the DRAM column address. Table 6.6 shows the correspondence between the settings of MXC1 and MXC0 and the address multiplexing method.

**Table 6.6 Settings of Bits MXC1 and MXC0 and Address Multiplexing Method**

	DRCRB		Column Address	Address Pins													
	MXC1	MXC0	Bits	A <sub>23</sub> to A <sub>13</sub>	A <sub>12</sub>	A <sub>11</sub>	A <sub>10</sub>	A <sub>9</sub>	A <sub>8</sub>	A <sub>7</sub>	A <sub>6</sub>	A <sub>5</sub>	A <sub>4</sub>	A <sub>3</sub>	A <sub>2</sub>	A <sub>1</sub>	A <sub>0</sub>
Row address	0	0	8 bits	A <sub>23</sub> to A <sub>13</sub>	A <sub>20</sub> *	A <sub>19</sub>	A <sub>18</sub>	A <sub>17</sub>	A <sub>16</sub>	A <sub>15</sub>	A <sub>14</sub>	A <sub>13</sub>	A <sub>12</sub>	A <sub>11</sub>	A <sub>10</sub>	A <sub>9</sub>	A <sub>8</sub>
		1	9 bits	A <sub>23</sub> to A <sub>13</sub>	A <sub>12</sub>	A <sub>20</sub> *	A <sub>19</sub>	A <sub>18</sub>	A <sub>17</sub>	A <sub>16</sub>	A <sub>15</sub>	A <sub>14</sub>	A <sub>13</sub>	A <sub>12</sub>	A <sub>11</sub>	A <sub>10</sub>	A <sub>9</sub>
	1	0	10 bits	A <sub>23</sub> to A <sub>13</sub>	A <sub>12</sub>	A <sub>11</sub>	A <sub>20</sub> *	A <sub>19</sub>	A <sub>18</sub>	A <sub>17</sub>	A <sub>16</sub>	A <sub>15</sub>	A <sub>14</sub>	A <sub>13</sub>	A <sub>12</sub>	A <sub>11</sub>	A <sub>10</sub>
		1	Illegal setting	—	—	—	—	—	—	—	—	—	—	—	—	—	—
Column address	—	—	—	A <sub>23</sub> to A <sub>13</sub>	A <sub>12</sub>	A <sub>11</sub>	A <sub>10</sub>	A <sub>9</sub>	A <sub>8</sub>	A <sub>7</sub>	A <sub>6</sub>	A <sub>5</sub>	A <sub>4</sub>	A <sub>3</sub>	A <sub>2</sub>	A <sub>1</sub>	A <sub>0</sub>

Note: \* Row address bit A<sub>20</sub> is not multiplexed in 1-Mbyte mode.

### 6.5.4 Data Bus

If the bit in ABWCR corresponding to an area designated as DRAM space is set to 1, that area is designated as 8-bit DRAM space; if the bit is cleared to 0, the area is designated as 16-bit DRAM space. In 16-bit DRAM space, × 16-bit organization DRAM can be connected directly.

In 8-bit DRAM space the upper half of the data bus, D<sub>15</sub> to D<sub>8</sub>, is enabled, while in 16-bit DRAM space both the upper and lower halves of the data bus, D<sub>15</sub> to D<sub>0</sub>, are enabled.

Access sizes and data alignment are the same as for the basic bus interface: see section 6.4.2, Data Size and Data Alignment.

### 6.5.5 Pins Used for DRAM Interface

Table 6.7 shows the pins used for DRAM interfacing and their functions.

**Table 6.7 DRAM Interface Pins**

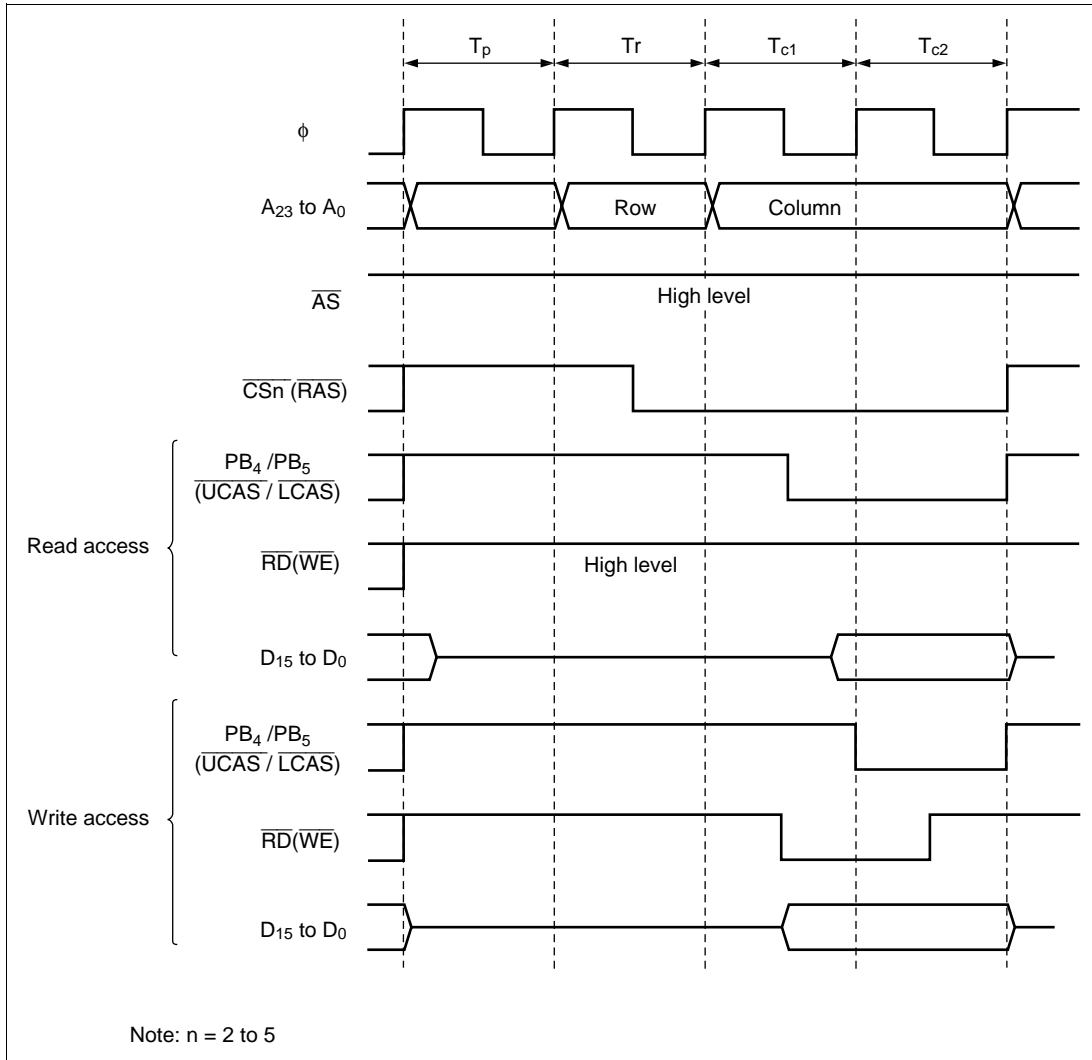
Pin	With DRAM Designated	Name	I/O	Function
PB4	$\overline{UCAS}$	Upper column address strobe	Output	Upper column address strobe for DRAM space access (when CSEL = 0 in DRCRB)
PB5	$\overline{LCAS}$	Lower column address strobe	Output	Lower column address strobe for DRAM space access (when CSEL = 0 in DRCRB)
$\overline{HWR}$	$\overline{UCAS}$	Upper column address strobe	Output	Upper column address strobe for DRAM space access (when CSEL = 1 in DRCRB)
$\overline{LWR}$	$\overline{LCAS}$	Lower column address strobe	Output	Lower column address strobe for DRAM space access (when CSEL = 1 in DRCRB)
$\overline{CS}_2$	$\overline{RAS}_2$	Row address strobe 2	Output	Row address strobe for DRAM space access
$\overline{CS}_3$	$\overline{RAS}_3$	Row address strobe 3	Output	Row address strobe for DRAM space access
$\overline{CS}_4$	$\overline{RAS}_4$	Row address strobe 4	Output	Row address strobe for DRAM space access
$\overline{CS}_5$	$\overline{RAS}_5$	Row address strobe 5	Output	Row address strobe for DRAM space access
$\overline{RD}$	$\overline{WE}$	Write enable	Output	Write enable for DRAM space write access*
P80	$\overline{RFSH}$	Refresh	Output	Goes low in refresh cycle
A <sub>12</sub> to A <sub>0</sub>	A <sub>12</sub> to A <sub>0</sub>	Address	Output	Row address/column address multiplexed output
D <sub>15</sub> to D <sub>0</sub>	D <sub>15</sub> to D <sub>0</sub>	Data	I/O	Data input/output pins

Note: \* Fixed high in a read access.

### 6.5.6 Basic Timing

Figure 6.18 shows the basic access timing for DRAM space. The basic DRAM access timing is four states: one precharge cycle ( $T_p$ ) state, one row address output cycle ( $T_r$ ) state, and two column address output cycle ( $T_{c1}$ ,  $T_{c2}$ ) states. Unlike the basic bus interface, the corresponding bits in ASTCR control only enabling or disabling of wait insertion between  $T_{c1}$  and  $T_{c2}$ , and do not affect the number of access states. When the corresponding bit in ASTCR is cleared to 0, wait states cannot be inserted between  $T_{c1}$  and  $T_{c2}$  in the DRAM access cycle.

If a DRAM read/write cycle is followed by an access cycle for an external area other than DRAM space when  $\overline{HWR}$  and  $\overline{LWR}$  are selected as the  $\overline{UCAS}$  and  $\overline{LCAS}$  output pins, an idle cycle ( $T_i$ ) is inserted unconditionally immediately after the DRAM access cycle. See section 6.9, Idle Cycle, for details.

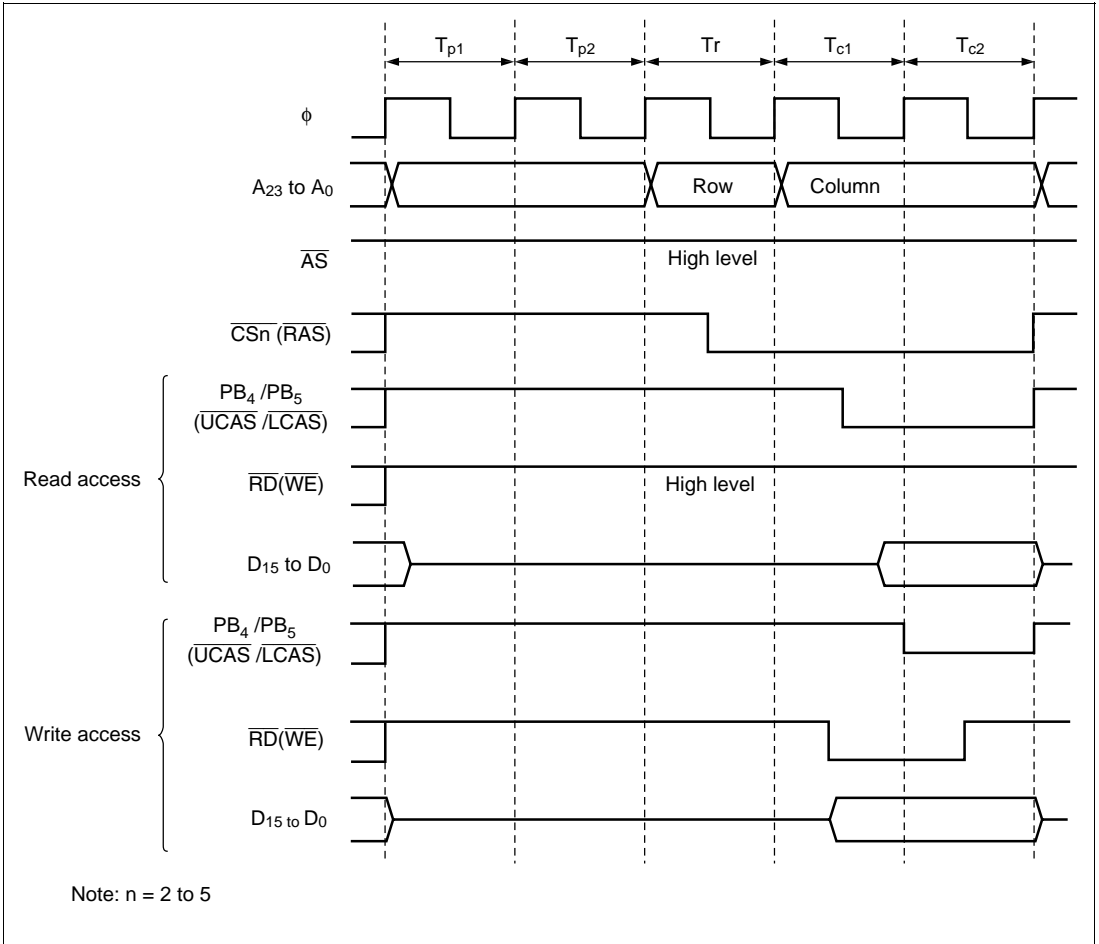


**Figure 6.18 Basic Access Timing (CSEL = 0 in DRCRB)**

### 6.5.7 Precharge State Control

In the H8/3067 Series, provision is made for the DRAM RAS precharge time by always inserting one RAS precharge state ( $T_p$ ) when DRAM space is accessed. This can be changed to two  $T_p$  states by setting the TPC bit to 1 in DRCRB. The optimum number of  $T_p$  cycles should be set according to the DRAM connected and the operating frequency of the H8/3067 Series chip. Figure 6.19 shows the timing when two  $T_p$  states are inserted.

When the TCP bit is set to 1, two  $T_p$  states are also used for CAS-before-RAS refresh cycles.



**Figure 6.19 Timing with Two Precharge States (CSEL = 0 in DRCRB)**

### 6.5.8 Wait Control

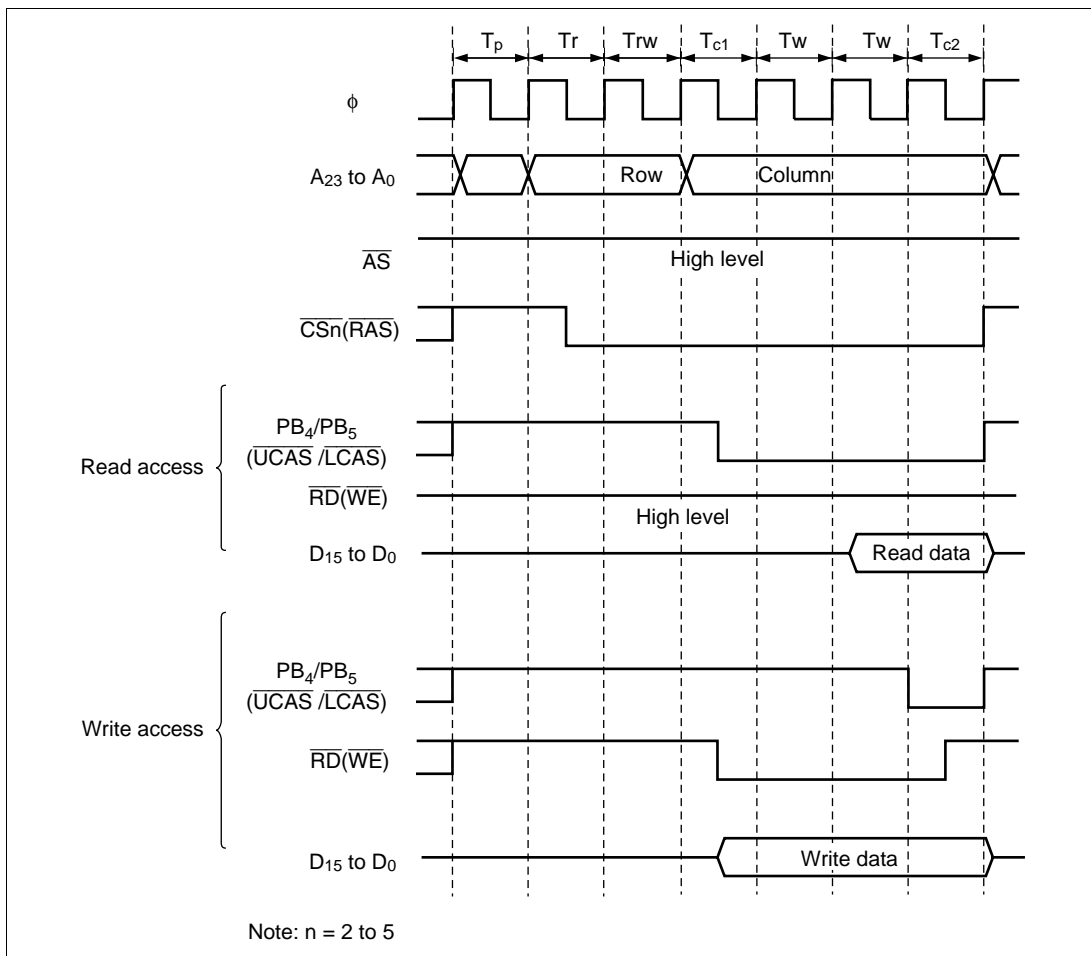
In a DRAM access cycle, wait states can be inserted (1) between the  $T_r$  state and  $T_{c1}$  state, and (2) between the  $T_{c1}$  state and  $T_{c2}$  state.

**Insertion of  $T_{rw}$  Wait State between  $T_r$  and  $T_{c1}$ :** One  $T_{rw}$  state can be inserted between  $T_r$  and  $T_{c1}$  by setting the RCW bit to 1 in DRCRB.

**Insertion of  $T_w$  Wait State(s) between  $T_{c1}$  and  $T_{c2}$ :** When the bit in ASTCR corresponding to an area designated as DRAM space is set to 1, from 0 to 3 wait states can be inserted between the  $T_{c1}$  state and  $T_{c2}$  state by means of settings in WCRH and WCRL.

Figure 6.20 shows an example of the timing for wait state insertion.

The settings of the RCW bit in DRCRB and of ASTCR, WCRH, and WCRL do not affect refresh cycles. Wait states cannot be inserted in a DRAM space access cycle by means of the  $\overline{\text{WAIT}}$  pin.



**Figure 6.20 Example of Wait State Insertion Timing (CSEL = 0)**

### 6.5.9 Byte Access Control and $\overline{\text{CAS}}$ Output Pin

When an access is made to DRAM space designated as a 16-bit-access area in ABWCR, column address strobes ( $\overline{\text{UCAS}}$  and  $\overline{\text{LCAS}}$ ) corresponding to the upper and lower halves of the external data bus are output. In the case of  $\times 16$ -bit organization DRAM, the 2-CAS type can be connected.

Either PB4 and PB5, or  $\overline{\text{HWR}}$  and  $\overline{\text{LWR}}$ , can be used as the  $\overline{\text{UCAS}}$  and  $\overline{\text{LCAS}}$  output pins, the selection being made with the CSEL bit in DRCRB. Table 6.8 shows the CSEL bit settings and corresponding output pin selections.



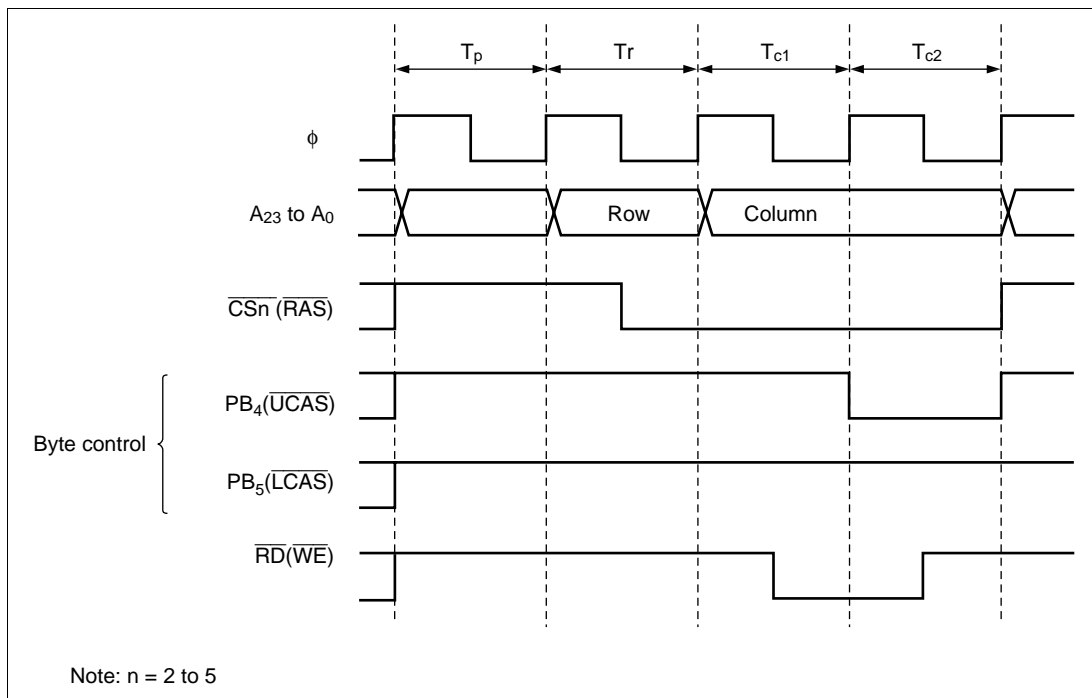
When an access is made to DRAM space designated as an 8-bit-access area in ABWCR, only  $\overline{UCAS}$  is output. When the entire DRAM space is designated as 8-bit-access space and  $CSEL = 0$ ,  $PB5$  can be used as an input/output port.

Note that  $\overline{RAS}$  down mode cannot be used when a device other than DRAM is connected to external space and  $\overline{HWR}$  and  $\overline{LWR}$  are used as write strobes. In this case, also, an idle cycle ( $T_i$ ) is always inserted when an external access to other than DRAM space occurs after a DRAM space access. For details, see section 6.9, Idle Cycle.

**Table 6.8 CSEL Settings and  $\overline{UCAS}$  and  $\overline{LCAS}$  Output Pins**

CSEL	$\overline{UCAS}$	$\overline{LCAS}$
0	PB4	PB5
1	$\overline{HWR}$	$\overline{LWR}$

Figure 6.21 shows the control timing.



**Figure 6.21 Control Timing (Upper-Byte Write Access When  $CSEL = 0$ )**

## 6.5.10 Burst Operation

With DRAM, in addition to full access (normal access) in which data is accessed by outputting a row address for each access, a fast page mode is also provided which can be used when making a number of consecutive accesses to the same row address. This mode enables fast (burst) access of data by simply changing the column address after the row address has been output. Burst access can be selected by setting the BE bit to 1 in DRCRA.

**Burst Access (Fast Page Mode) Operation Timing:** Figure 6.22 shows the operation timing for burst access. When there are consecutive access cycles for DRAM space, the column address and  $\overline{\text{CAS}}$  signal output cycles (two states) continue as long as the row address is the same for consecutive access cycles. In burst access, too, the bus cycle can be extended by inserting wait states between  $T_{c1}$  and  $T_{c2}$ . The wait state insertion method and timing are the same as for full access: see section 6.5.8, Wait Control, for details.

The row address used for the comparison is determined by the bus width of the relevant area set in bits MXC1 and MXC0 in BRCRB, and in ABWCR. Table 6.9 shows the compared row addresses corresponding to the various settings of bits MXC1 and MXC0, and ABWCR.

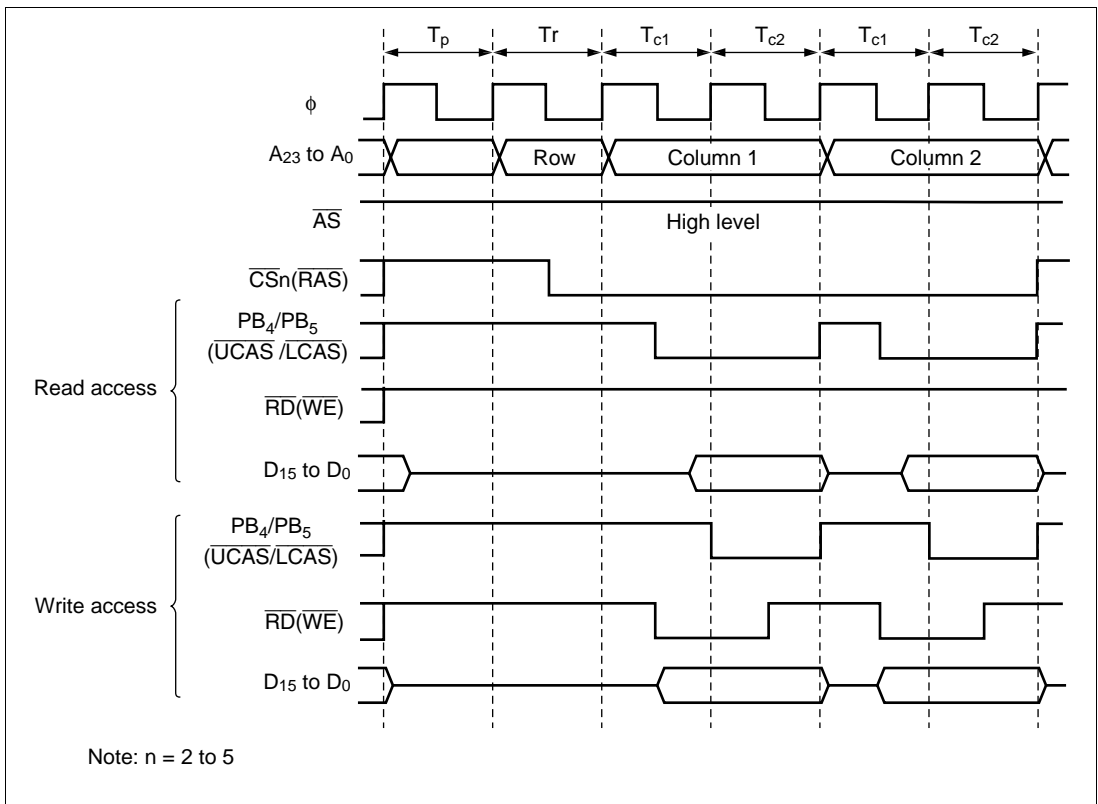


Figure 6.22 Operation Timing in Fast Page Mode

**Table 6.9 Correspondence between Settings of MXC1 and MXC0 Bits and ABWCR, and Row Address Compared in Burst Access**

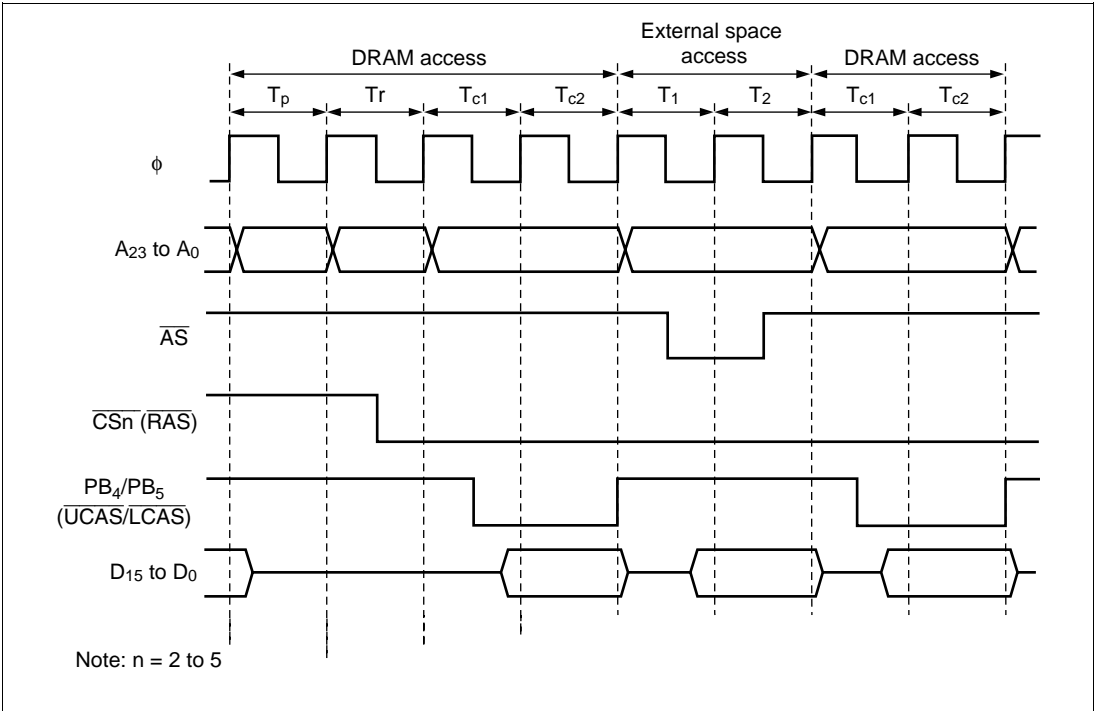
Operating Mode	DRCRB		ABWCR		Compared Row Address
	MXC1	MXC0	ABWn	Bus Width	
Modes 1 and 2 (1-Mbyte)	0	0	0	16 bits	A19 to A9
			1	8 bits	A19 to A8
	1	0	0	16 bits	A19 to A10
			1	8 bits	A19 to A9
		0	0	16 bits	A19 to A11
			1	8 bits	A19 to A10
1	—	—	—	Illegal setting	
Modes 3, 4, and 5 (16-Mbyte)	0	0	0	16 bits	A23 to A9
			1	8 bits	A23 to A8
	1	0	0	16 bits	A23 to A10
			1	8 bits	A23 to A9
		0	0	16 bits	A23 to A11
			1	8 bits	A23 to A10
1	—	—	—	Illegal setting	

Note: n = 2 to 5

**RAS Down Mode and RAS Up Mode:** With DRAM provided with fast page mode, as long as accesses are to the same row address, burst operation can be continued without interruption even if accesses are not consecutive by holding the RAS signal low.

- RAS Down Mode

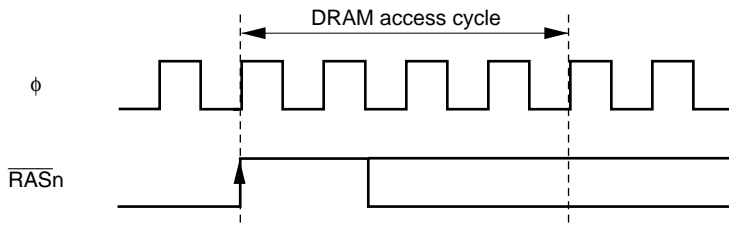
To select RAS down mode, set the BE and RDM bits to 1 in DRCRA. If access to DRAM space is interrupted and another space is accessed, the  $\overline{\text{RAS}}$  signal is held low during the access to the other space, and burst access is performed if the row address of the next DRAM space access is the same as the row address of the previous DRAM space access. Figure 6.23 shows an example of the timing in RAS down mode.



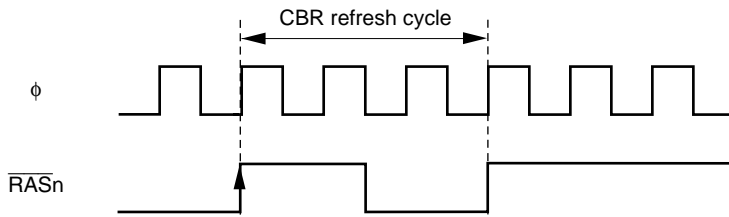
**Figure 6.23 Example of Operation Timing in RAS Down Mode (CSEL = 0)**

When RAS down mode is selected, the conditions for an asserted  $\overline{\text{RAS}}_n$  signal to return to the high level are as shown below. The timing in these cases is shown in figure 6.24.

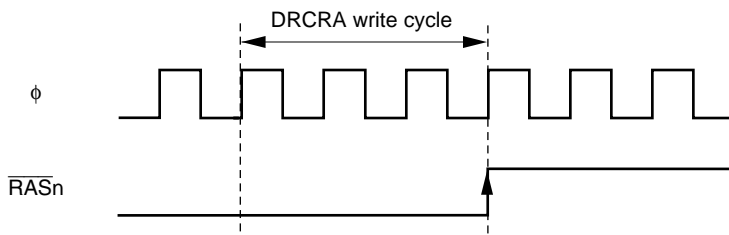
- When DRAM space with a different row address is accessed
- Immediately before a CAS-before-RAS refresh cycle
- When the BE bit or RDM bit is cleared to 0 in DRCRA
- Immediately before release of the external bus



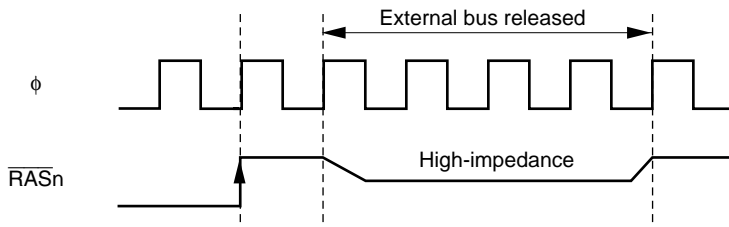
(a) Access to DRAM space with a different row address



(b) CAS-before-RAS refresh cycle



(c) BE bit or RDM bit cleared to 0 in DRCRA



(d) External bus released

Note: n = 2 to 5

**Figure 6.24**  $\overline{\text{RASn}}$  Negation Timing when RAS Down Mode is Selected

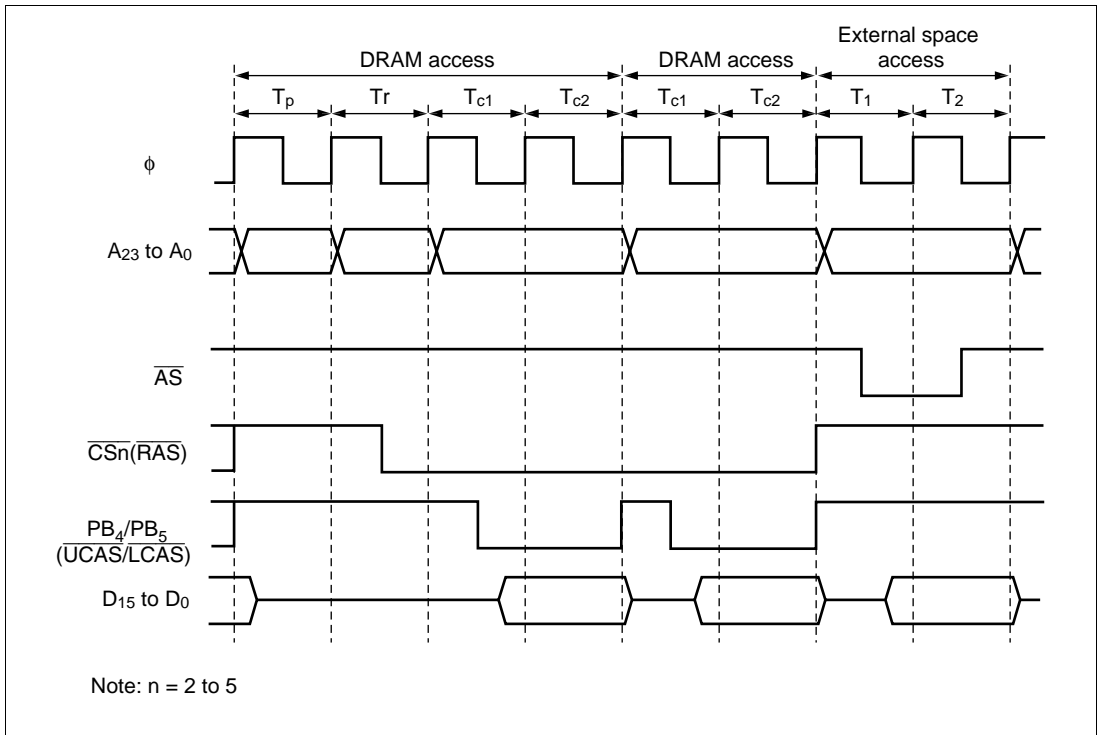
When RAS down mode is selected, the CAS-before-RAS refresh function provided with this DRAM interface must always be used as the DRAM refreshing method. When a refresh operation is performed, the  $\overline{\text{RAS}}$  signal goes high immediately beforehand. The refresh interval setting must be made so that the maximum DRAM RAS pulse width specification is observed.

When the self-refresh function is used, the RDM bit must be cleared to 0, and RAS up mode selected, before executing a SLEEP instruction in order to enter software standby mode. Select RAS down mode again after exiting software standby mode.

Note that RAS down mode cannot be used when  $\overline{\text{HWR}}$  and  $\overline{\text{LWR}}$  are selected for  $\overline{\text{UCAS}}$  and  $\overline{\text{LCAS}}$ , a device other than DRAM is connected to external space, and  $\overline{\text{HWR}}$  and  $\overline{\text{LWR}}$  are used as write strobes.

- RAS Up Mode

To select RAS up mode, clear the RDM bit to 0 in DRCRA. Each time access to DRAM space is interrupted and another space is accessed, the  $\overline{\text{RAS}}$  signal returns to the high level. Burst operation is only performed if DRAM space is continuous. Figure 6.25 shows an example of the timing in RAS up mode.



**Figure 6.25 Example of Operation Timing in RAS Up Mode**

## 6.5.11 Refresh Control

The H8/3067 Series is provided with a CAS-before-RAS (CBR) function and self-refresh function as DRAM refresh control functions.

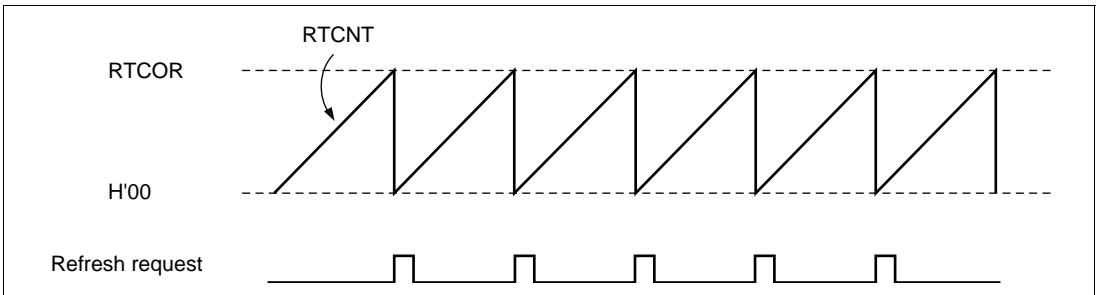
**CAS-Before-RAS (CBR) Refreshing:** To select CBR refreshing, set the RCYCE bit to 1 in DRCRB.

With CBR refreshing, RTCNT counts up using the input clock selected by bits CKS2 to CKS0 in RTMCSR, and a refresh request is generated when the count matches the value set in RTCOR (compare match). At the same time, RTCNT is reset and starts counting up again from H'00. Refreshing is thus repeated at fixed intervals determined by RTCOR and bits CKS2 to CKS0. A refresh cycle is executed after this refresh request has been accepted and the DRAM interface has acquired the bus. Set a value in bits CKS2 to CKS0 in RTCOR that will meet the refresh interval specification for the DRAM used. When RAS down mode is used, set the refresh interval so that the maximum  $\overline{\text{RAS}}$  pulse width specification is met.

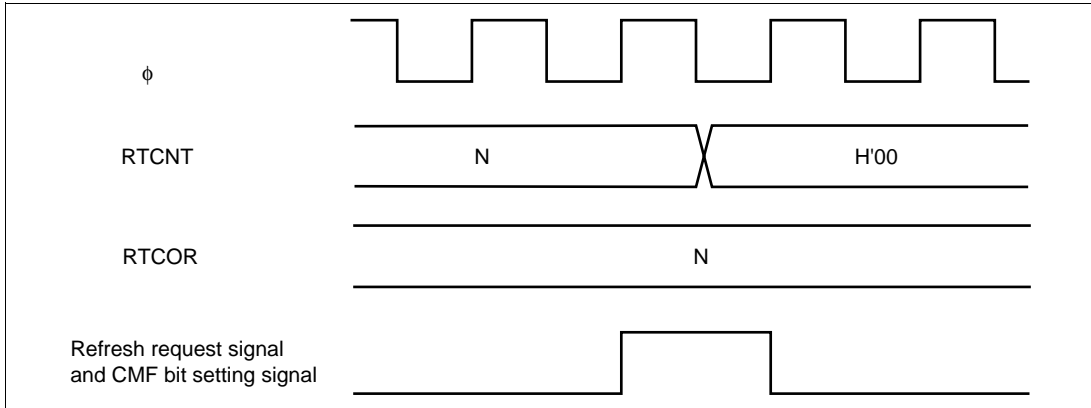
RTCNT starts counting up when bits CKS2 to CKS0 are set. RTCNT and RTCOR settings should therefore be completed before setting bits CKS2 to CKS0.

Also note that a repeat refresh request generated during a bus request, or a refresh request during refresh cycle execution, will be ignored.

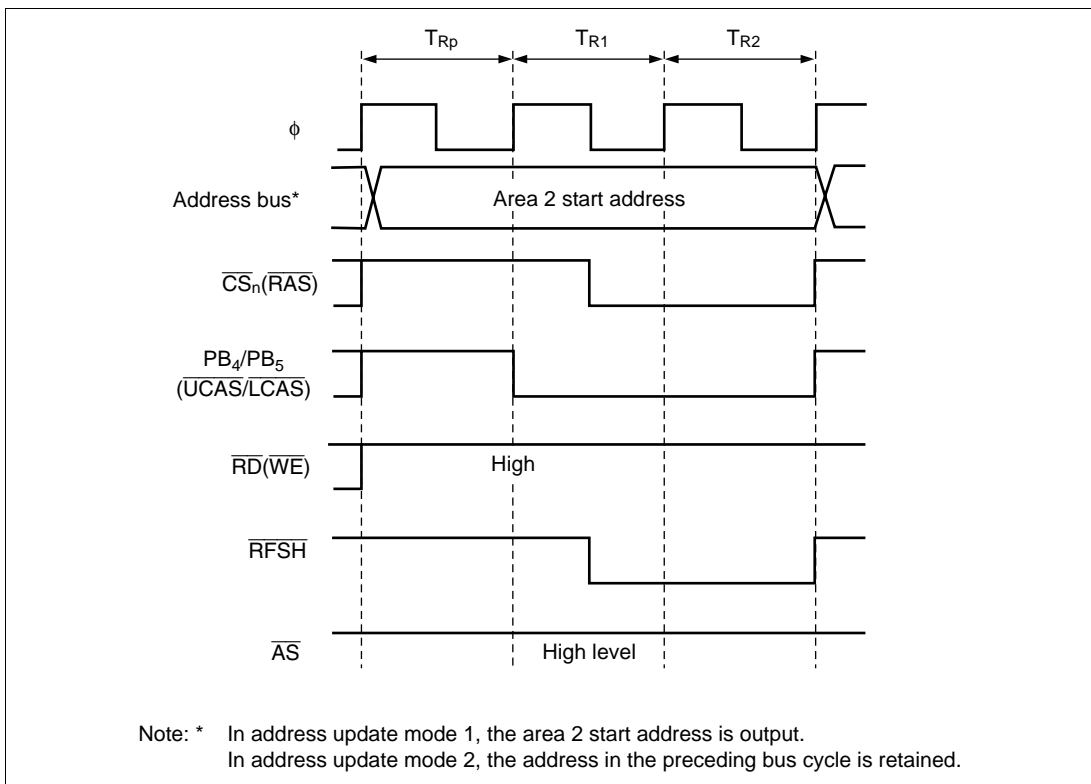
RTCNT operation is shown in figure 6.26, compare match timing in figure 6.27, and CBR refresh timing in figures 6.28 and 6.29.



**Figure 6.26 RTCNT Operation**



**Figure 6.27 Compare Match Timing**



**Figure 6.28 CBR Refresh Timing (CSEL = 0, TPC = 0, RLW = 0)**

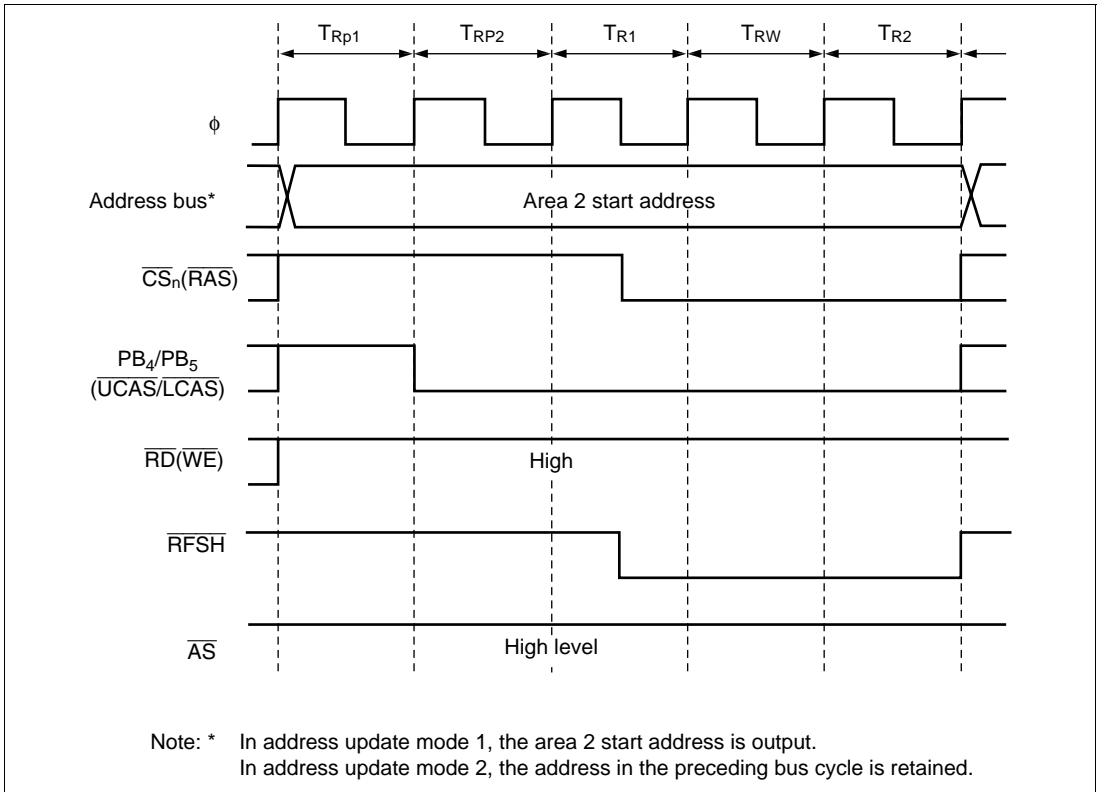
The basic CBS refresh cycle timing comprises three states: one RAS precharge cycle ( $T_{Rp}$ ) state, and two RAS output cycle ( $T_{R1}$ ,  $T_{R2}$ ) states. Either one or two states can be selected for the RAS precharge cycle. When the TPC bit is set to 1 in DRCRB,  $\overline{RAS}$  signal output is delayed by one cycle. This does not affect the timing of  $\overline{UCAS}$  and  $\overline{LCAS}$  output.



Use the RLW bit in DRCRB to adjust the  $\overline{\text{RAS}}$  signal width. A single refresh wait state ( $T_{\text{RW}}$ ) can be inserted between the  $T_{\text{R1}}$  state and  $T_{\text{R2}}$  state by setting the RLW bit to 1.

The RLW bit setting is valid only for CBR refresh cycles, and does not affect DRAM read/write cycles. The number of states in the CBR refresh cycle is not affected by the settings in ASTCR, WCRH, or WCRL, or by the state of the  $\overline{\text{WAIT}}$  pin.

Figure 6.29 shows the timing when the TPC bit and RLW bit are both set to 1.



**Figure 6.29 CBR Refresh Timing (CSEL = 0, TPC = 1, RLW = 1)**

DRAM must be refreshed immediately after powering on in order to stabilize its internal state. When using the H8/3067 Series CAS-before-RAS refresh function, therefore, a DRAM stabilization period should be provided by means of interrupts by another timer module, or by counting the number of times bit 7 (CMF) of RTMCSR is set, for instance, immediately after bits DRAS2 to DRAS0 have been set in DRCRA.

**Self-Refreshing:** A self-refresh mode (battery backup mode) is provided for DRAM as a kind of standby mode. In this mode, refresh timing and refresh addresses are generated within the DRAM. The H8/3067 Series has a function that places the DRAM in self-refresh mode when the chip enters software standby mode.

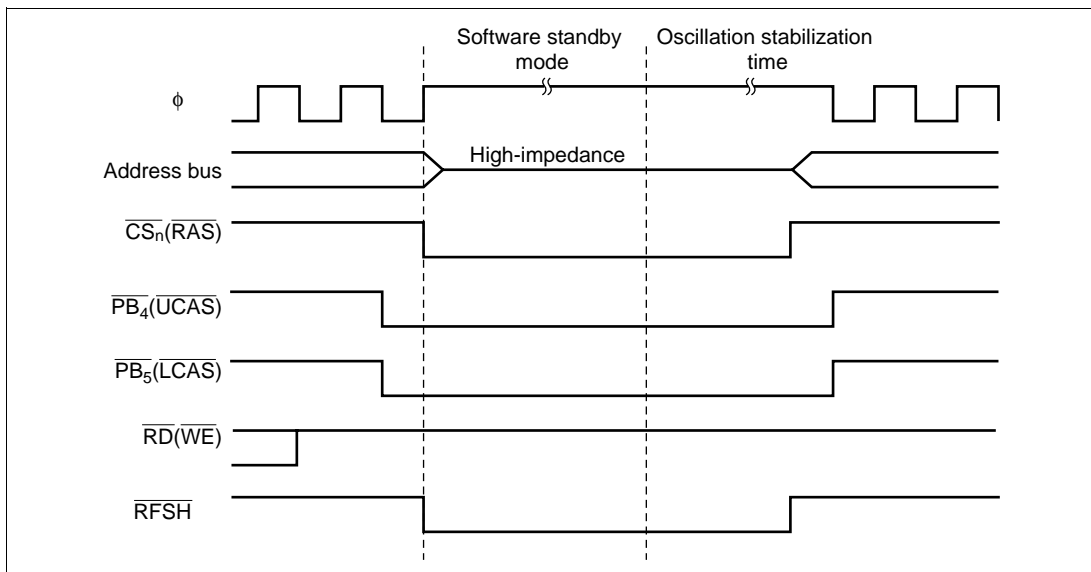
To use the self-refresh function, set the SRFMD bit to 1 in DRCRA. When a  $\overline{\text{SLEEP}}$  instruction is subsequently executed in order to enter software standby mode, the  $\overline{\text{CAS}}$  and  $\overline{\text{RAS}}$  signals are output and the DRAM enters self-refresh mode, as shown in figure 6.30.

When the chip exits software standby mode,  $\overline{\text{CAS}}$  and  $\overline{\text{RAS}}$  outputs go high.

The following conditions must be observed when the self-refresh function is used:

- When burst access is selected, RAS up mode must be selected before executing a SLEEP instruction in order to enter software standby mode. Therefore, if RAS down mode has been selected, the RDM bit in DRCRA must be cleared to 0 and RAS up mode selected before executing the SLEEP instruction. Select RAS down mode again after exiting software standby mode.
- The instruction immediately following a SLEEP instruction must not be located in an area designated as DRAM space.

The self-refresh function will not work properly unless the above conditions are observed.



**Figure 6.30 Self-Refresh Timing (CSEL = 0)**

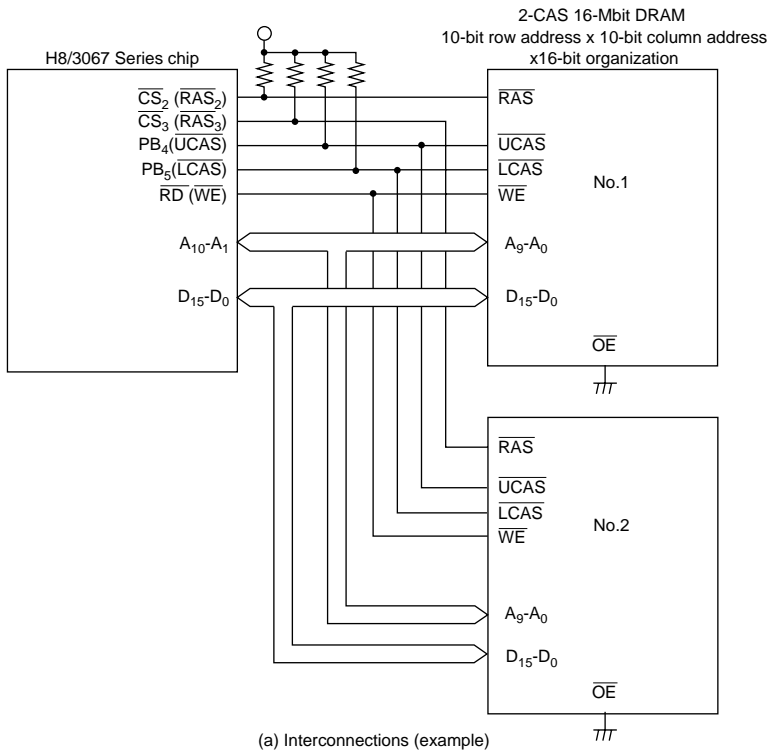
**Refresh Signal ( $\overline{\text{RFSH}}$ ):** A refresh signal ( $\overline{\text{RFSH}}$ ) that transmits a refresh cycle off-chip can be output by setting the RFSHE bit to 1 in DRCRA.  $\overline{\text{RFSH}}$  output timing is shown in figures 6.28, 6.29, and 6.30.

## 6.5.12 Examples of Use

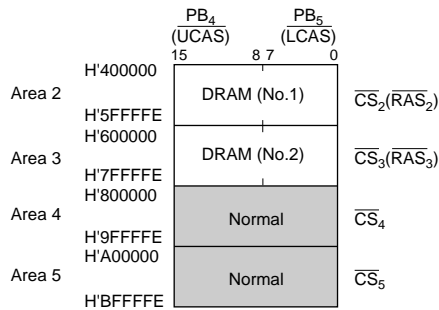
Examples of DRAM connection and program setup procedures are shown below. When the DRAM interface is used, check the DRAM device characteristics and choose the most appropriate method of use for that device.

### Connection Examples

- Figure 6.31 shows typical interconnections when using two 2-CAS type 16-Mbit DRAMs using a  $\times 16$ -bit organization, and the corresponding address map. The DRAMs used in this example are of the 10-bit row address  $\times$  10-bit column address type. Up to four DRAMs can be connected by designating areas 2 to 5 as DRAM space.



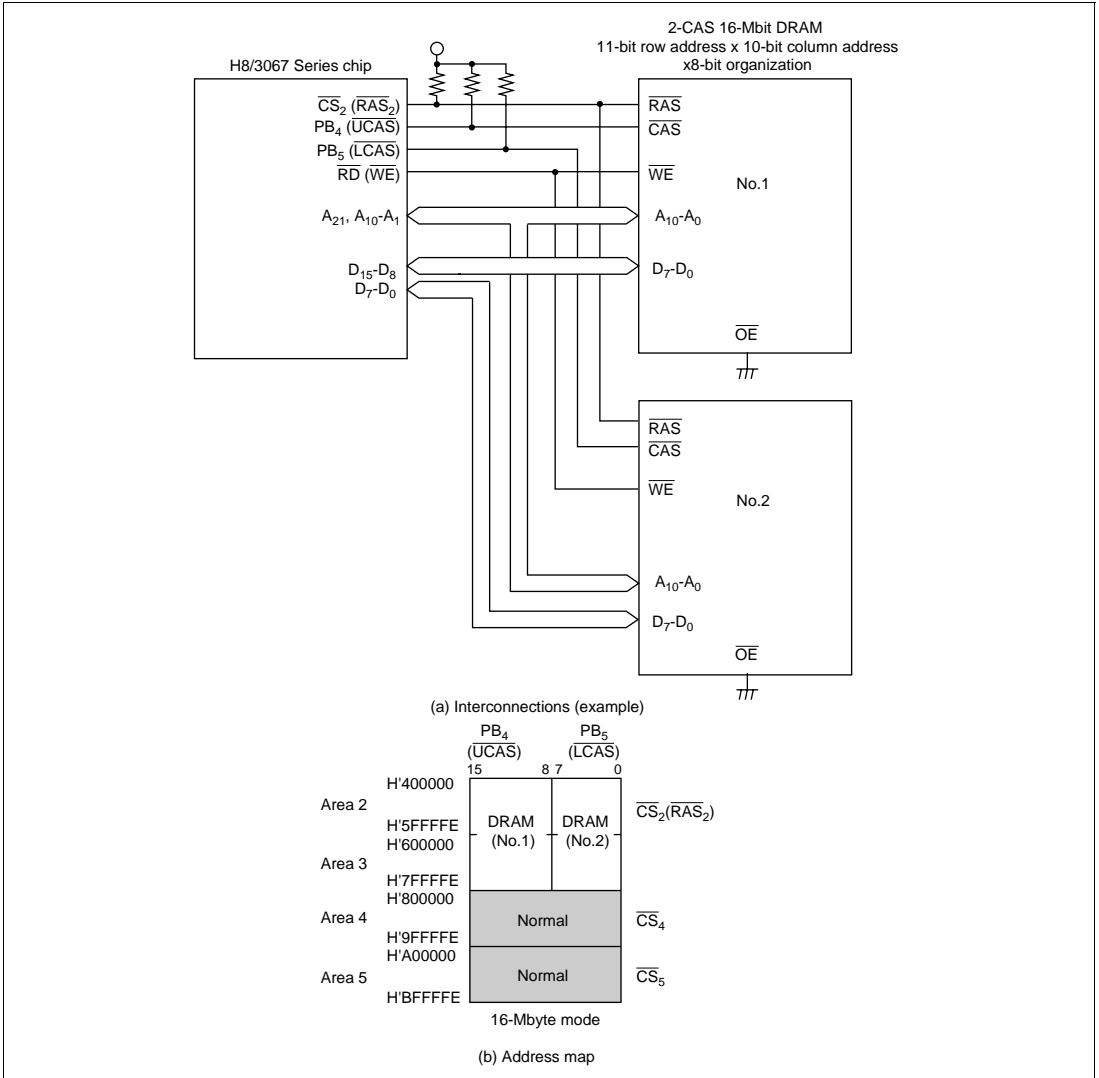
(a) Interconnections (example)



(b) Address map

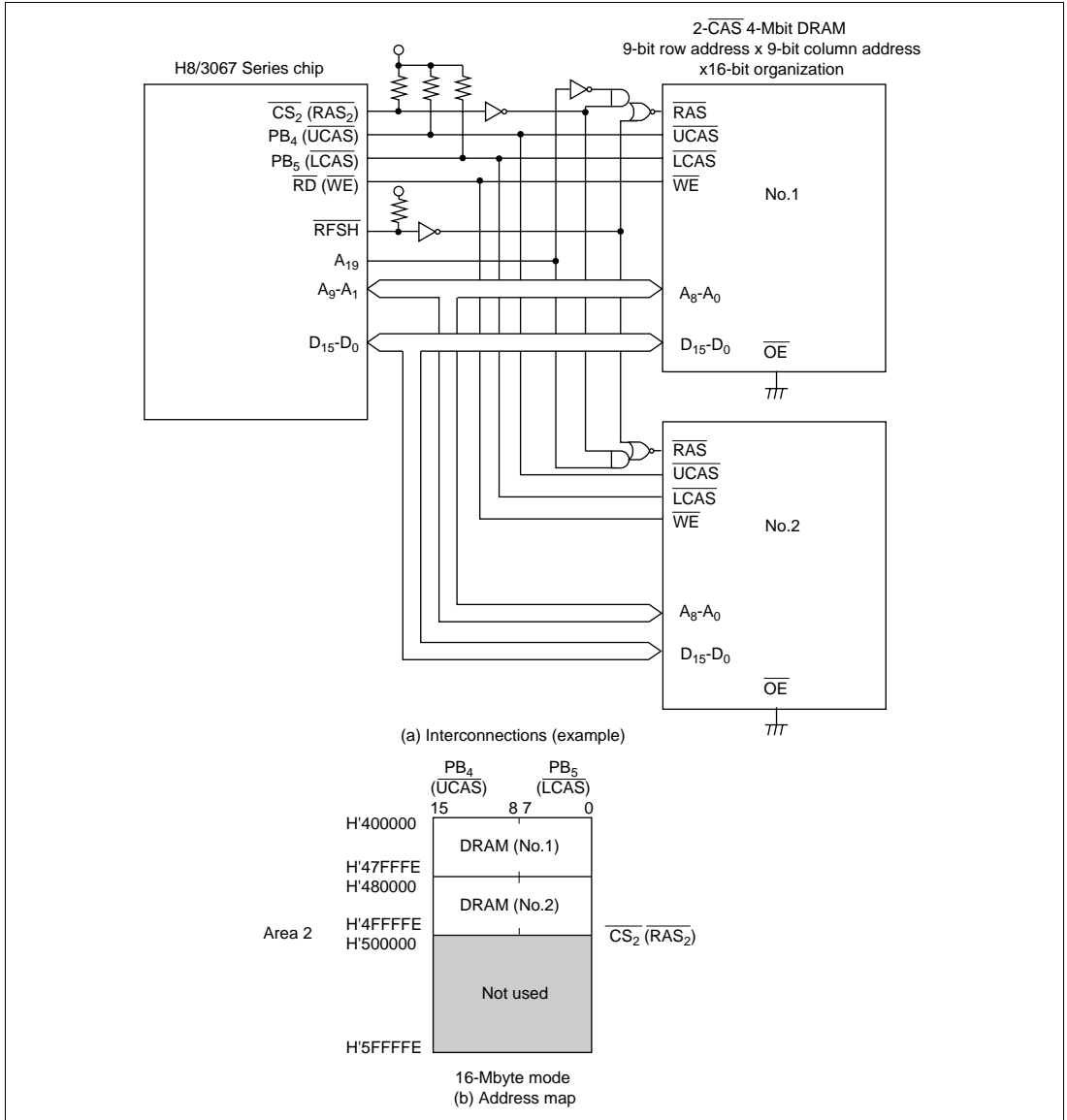
**Figure 6.31 Interconnections and Address Map for 2-CAS 16-Mbit DRAMs with ×16-Bit Organization**

- Figure 6.32 shows typical interconnections when using two 16-Mbit DRAMs using a  $\times 8$ -bit organization, and the corresponding address map. The DRAMs used in this example are of the 11-bit row address  $\times$  10-bit column address type. The  $\overline{CS}_2$  pin is used as the common  $\overline{RAS}$  output pin for areas 2 and 3. When the DRAM address space spans a number of contiguous areas, as in this example, the appropriate setting of bits DRAS2 to DRAS0 enables a single  $\overline{CS}$  pin to be used as the common  $\overline{RAS}$  output pin for a number of areas, and makes it possible to directly connect large-capacity DRAM with address space that spans a maximum of four areas. Any unused  $\overline{CS}$  pins (in this example, the  $\overline{CS}_3$  pin) can be used as input/output ports.



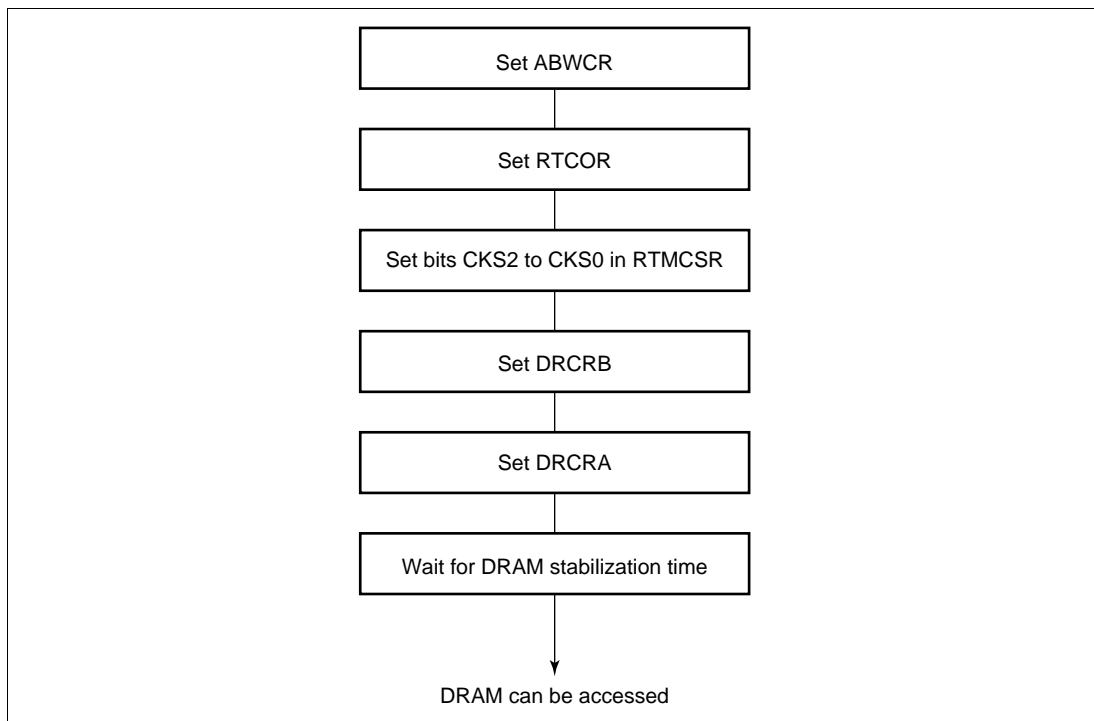
**Figure 6.32 Interconnections and Address Map for 16-Mbit DRAMs with  $\times 8$ -Bit Organization**

- Figure 6.33 shows typical interconnections when using two 4-Mbit DRAMs, and the corresponding address map. The DRAMs used in this example are of the 9-bit row address  $\times$  10-bit column address type. In this example, upper address decoding allows multiple DRAMs to be connected to a single area. The RFSH pin is used in this case, since both DRAMs must be refreshed simultaneously. However, note that RAS down mode cannot be used in this interconnection example.



**Figure 6.33 Interconnections and Address Map for 2-CAS 4-Mbit DRAMs with  $\times$  16-Bit Organization**

**Example of Program Setup Procedure:** Figure 6.34 shows an example of the program setup procedure.



**Figure 6.34 Example of Setup Procedure when Using DRAM Interface**

### 6.5.13 Usage Notes

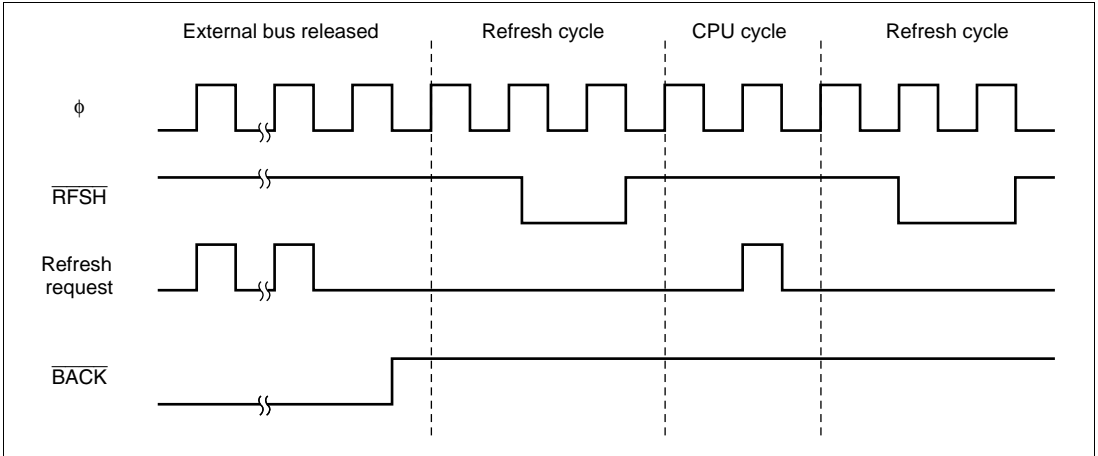
Note the following points when using the DRAM refresh function.

- Refresh cycles will not be executed when the external bus released state, software standby mode, or a bus cycle is extended by means of wait state insertion. Refreshing must therefore be performed by other means in these cases.
- If a refresh request is generated internally while the external bus is released, the first request is retained and a single refresh cycle will be executed after the bus-released state is cleared. Figure 6.35 shows the bus cycle in this case.
- When a bus cycle is extended by means of wait state insertion, the first request is retained in the same way as when the external bus has been released.
- In the event of contention with a bus request from an external bus master when a transition is made to software standby mode, the  $\overline{\text{BACK}}$  and strobe states may be indeterminate after the transition to software standby mode (see figure 6.36).

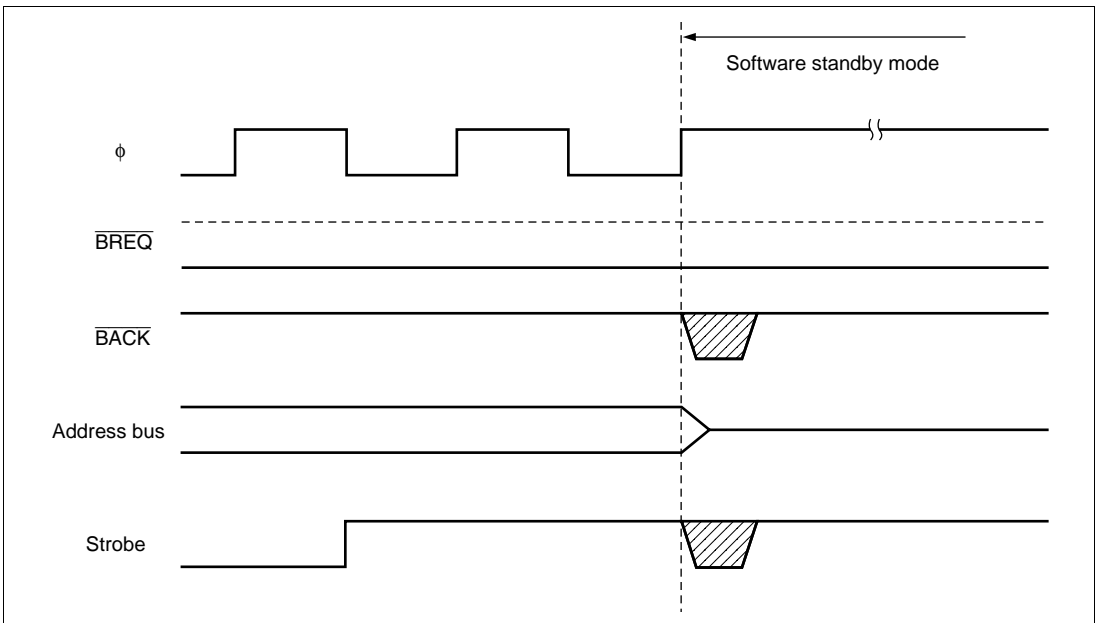
When software standby mode is used, the BRLE bit should be cleared to 0 in BRCCR before executing the SLEEP instruction.

Similar contention in a transition to self-refresh mode may prevent dependable strobe waveform output. This can also be avoided by clearing the BRLW bit to 0 in BRCCR.

- Immediately after self-refreshing is cleared, external bus release is possible during a given period until the start of a CPU cycle. Attention must be paid to the  $\overline{\text{RAS}}$  state to ensure that the specification for the  $\overline{\text{RAS}}$  precharge time immediately after self-refreshing is met.

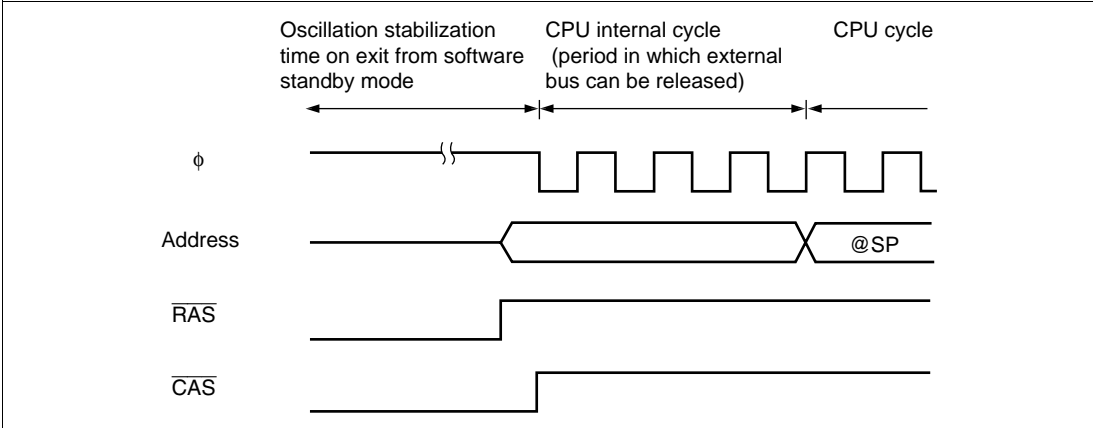


**Figure 6.35 Bus-Released State and Refresh Cycles**



**Figure 6.36 Bus-Released State and Software Standby Mode**





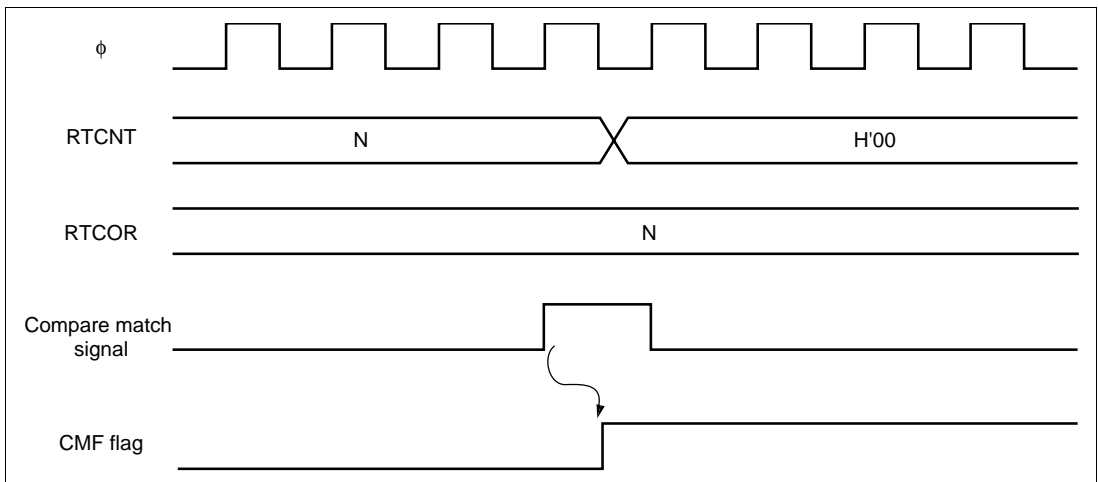
**Figure 6.37 Self-Refresh Clearing**

## 6.6 Interval Timer

### 6.6.1 Operation

When DRAM is not connected to the H8/3067 Series chip, the refresh timer can be used as an interval timer by clearing bits DRAS2 to DRAS0 in DRCRA to 0. After setting RTCOR, selection a clock source with bits CKS2 to CKS0 in RTMCSR, and set the CMIE bit to 1.

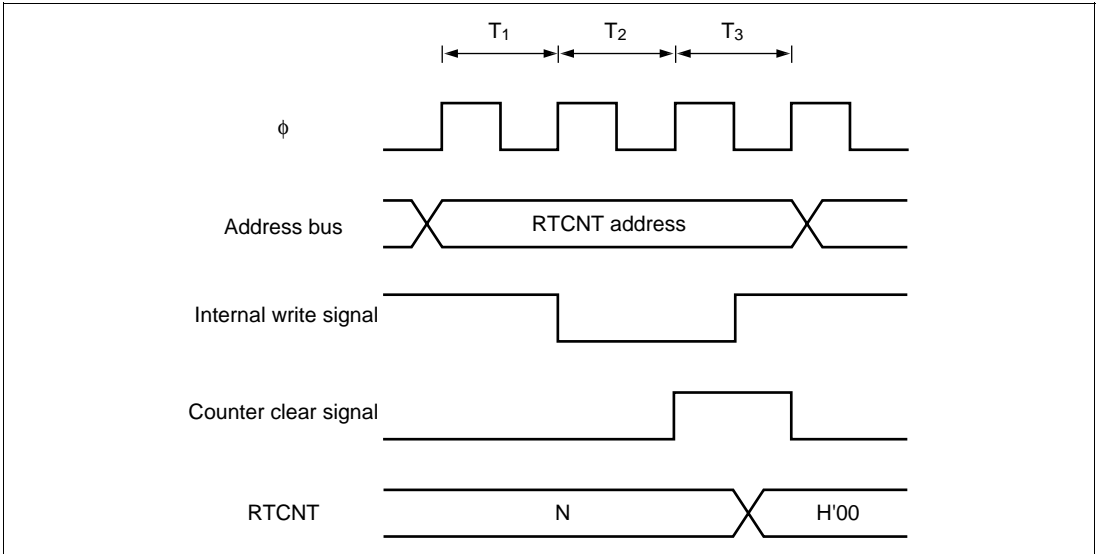
**Timing of Setting of Compare Match Flag and Clearing by Compare Match:** The CMF flag in RTMCSR is set to 1 by a compare match output when the RTCOR and RTCNT values match. The compare match signal is generated in the last state in which the values match (when RTCNT is updated from the matching value to a new value). Accordingly, when RTCNT and RTCOR match, the compare match signal is not generated until the next counter clock pulse. Figure 6.38 shows the timing.



**Figure 6.38 Timing of CMF Flag Setting**

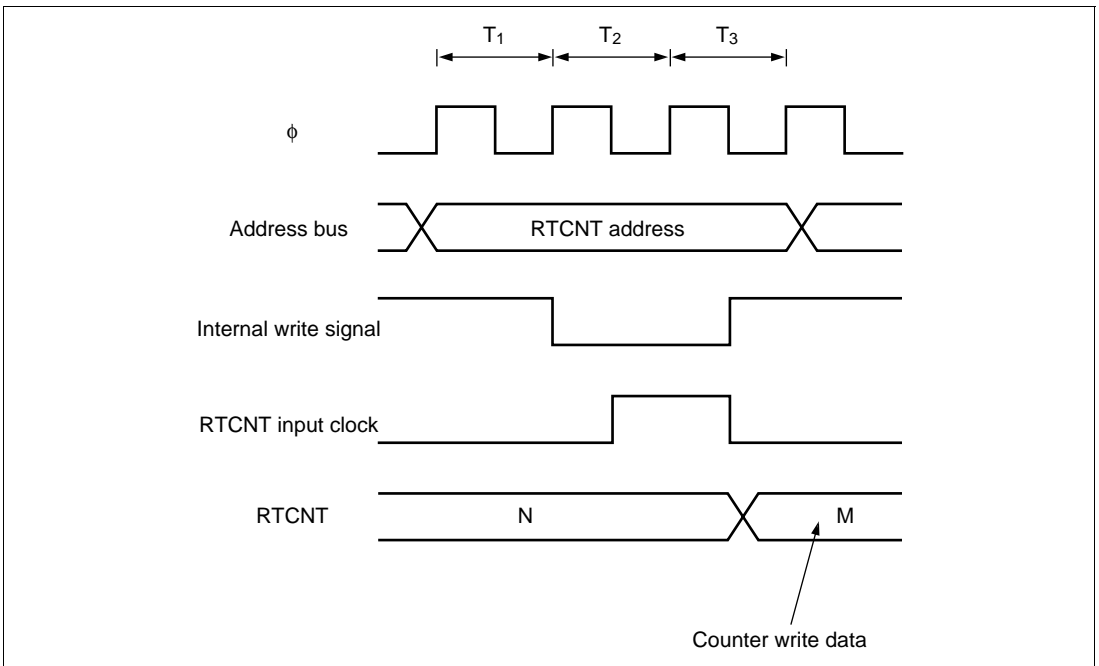
**Operation in Power-Down State:** The interval timer operates in sleep mode. It does not operate in hardware standby mode. In software standby mode, RTCNT and RTMCSR bits 7 and 6 are initialized, but RTMCSR bits 5 to 3 and RTCOR retain their settings prior to the transition to software standby mode.

**Contention between RTCNT Write and Counter Clear:** If a counter clear signal occurs in the T<sub>3</sub> state of an RTCNT write cycle, clearing of the counter takes priority and the write is not performed. See Figure 6.39.



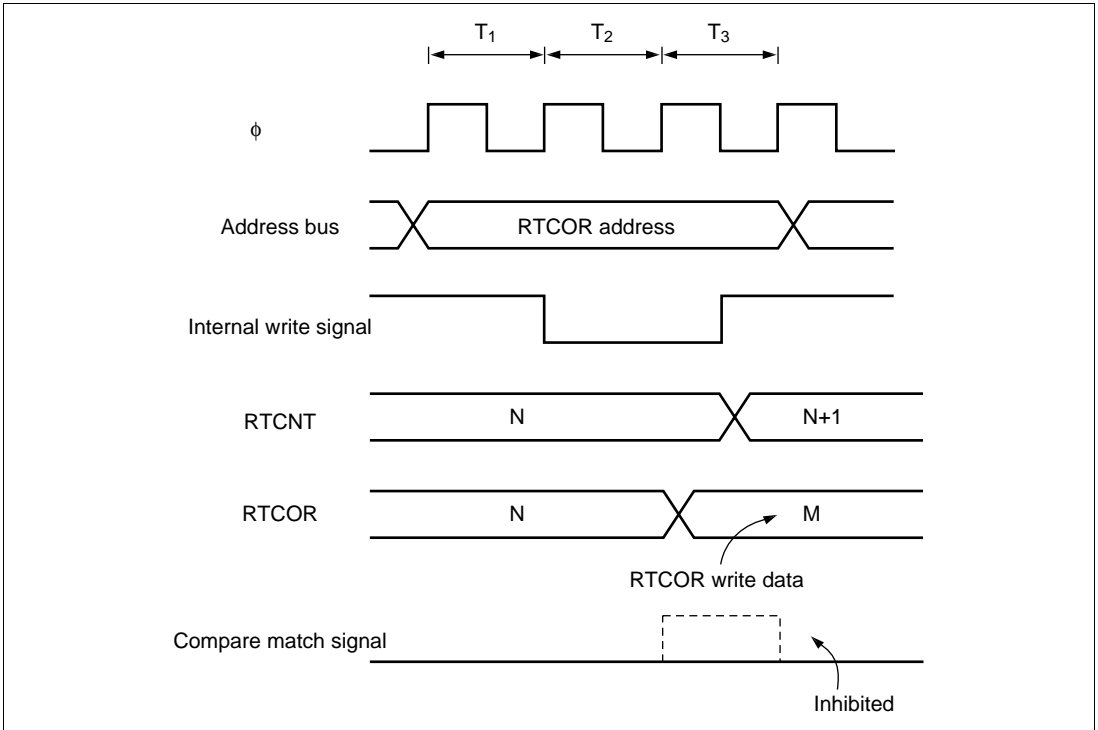
**Figure 6.39 Contention between RTCNT Write and Clear**

**Contention between RTCNT Write and Increment:** If an increment pulse occurs in the T<sub>3</sub> state of an RTCNT write cycle, writing takes priority and RTCNT is not incremented. See Figure 6.40.



**Figure 6.40 Contention between RTCNT Write and Increment**

**Contention between RTCOR Write and Compare Match:** If a compare match occurs in the  $T_3$  state of an RTCOR write cycle, writing takes priority and the compare match signal is inhibited. See Figure 6.41.

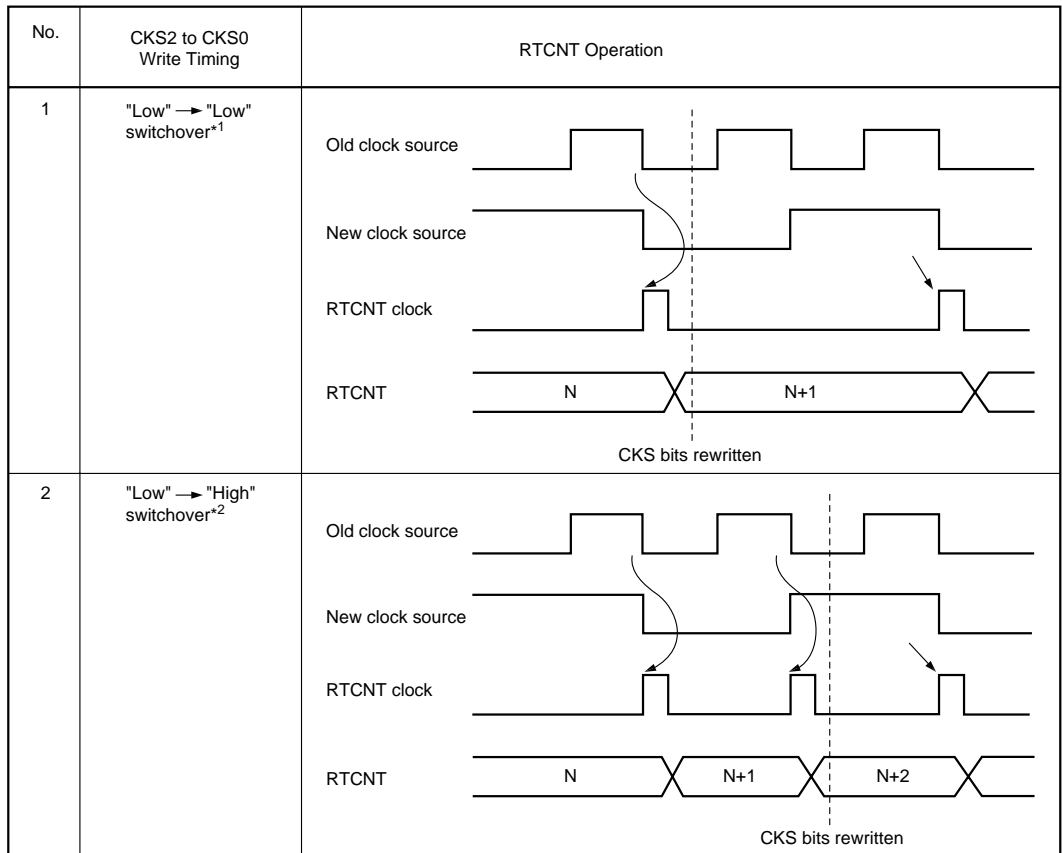


**Figure 6.41 Contention between RTCOR Write and Compare Match**

**RTCNT Operation at Internal Clock Source Switchover:** Switching internal clock sources may cause RTCNT to increment, depending on the switchover timing. Table 6.10 shows the relation between the time of the switchover (by writing to bits CKS2 to CKS0) and the operation of RTCNT.

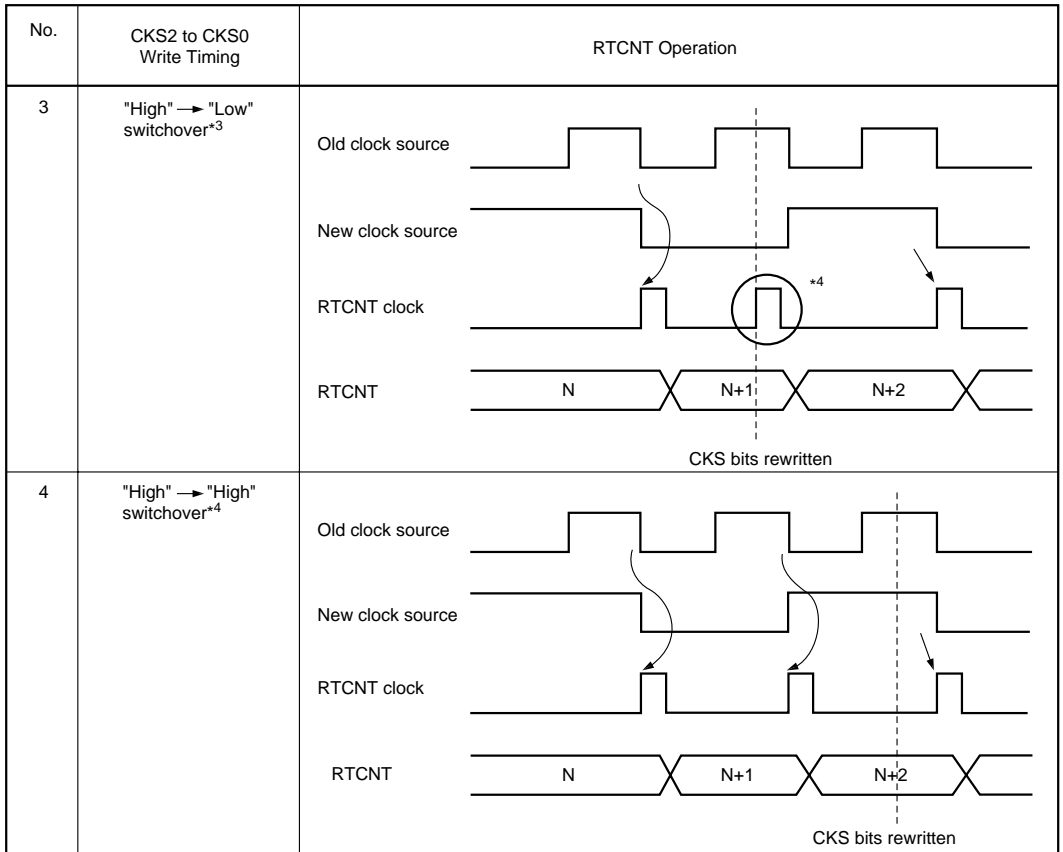
The RTCNT input clock is generated from the internal clock source by detecting the falling edge of the internal clock. If a switchover is made from a high clock source to a low clock source, as in case No. 3 in table 6.10, the switchover will be regarded as a falling edge, an RTCNT clock pulse will be generated, and RTCNT will be incremented.

**Table 6.10 Internal Clock Switchover and RTCNT Operation (1)**



Notes: 1. Including switchovers from a low clock source to the halted state, and from the halted state to a low clock source.  
 2. Including switchover from the halted state to a high clock source.

**Table 6.10 Internal Clock Switchover and RTCNT Operation (2)**



- Notes: 3. Including switchover from a high clock source to the halted state.  
 4. The switchover is regarded as a falling edge, causing RTCNT to increment.

## 6.7 Interrupt Sources

Compare match interrupts (CMI) can be generated when the refresh timer is used as an interval timer. Compare match interrupt requests are masked/unmasked with the CMIE bit in RTMCSR.

## 6.8 Burst ROM Interface

### 6.8.1 Overview

With the H8/3067 Series, external space area 0 can be designated as burst ROM space, and burst ROM space interfacing can be performed. The burst ROM space interface enables 16-bit organization ROM with burst access capability to be accessed at high speed. Area 0 is designated as burst ROM space by means of the BROME bit in BCR.

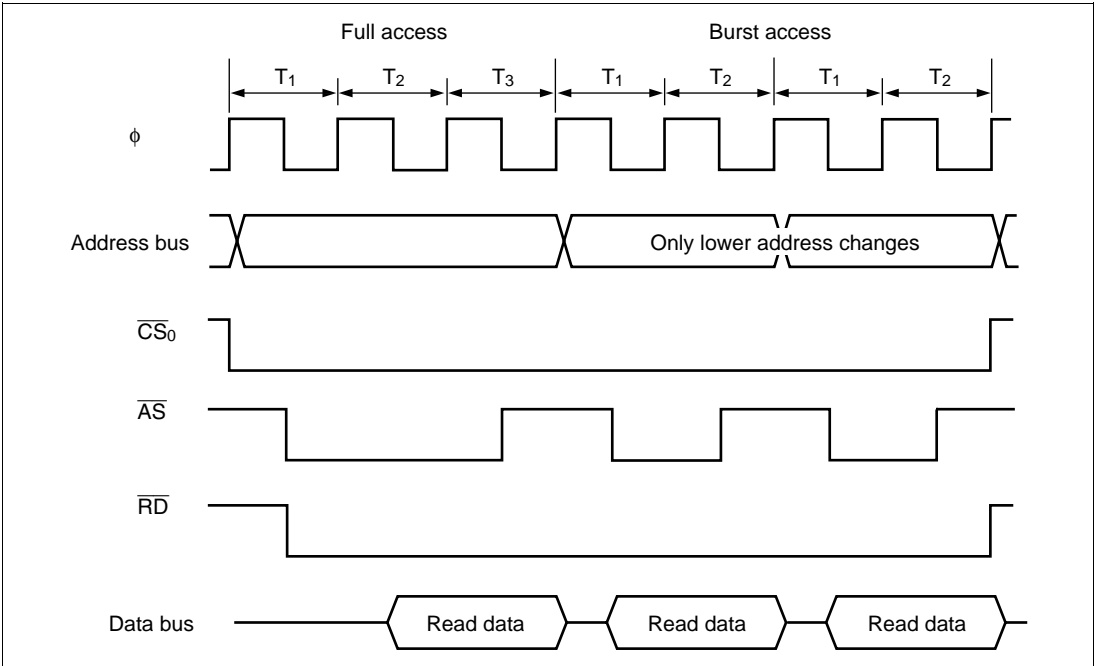
Continuous burst access of a maximum of four or eight words can be performed on external space area 0. Two or three states can be selected for burst access.

### 6.8.2 Basic Timing

The number of states in the initial cycle (full access) and a burst cycle of the burst ROM interface is determined by the setting of the AST0 bit in ASTCR. When the AST0 bit is set to 1, wait states can also be inserted in the initial cycle. Wait states cannot be inserted in a burst cycle.

Burst access of up to four words is performed when the BRSTS0 bit is cleared to 0 in BCR, and burst access of up to eight words when the BRSTS0 bit is set to 1. The number of burst access states is two when the BRSTS1 bit is cleared to 0, and three when the BRSTS1 bit is set to 1.

The basic access timing for burst ROM space is shown in figure 6.42.



**Figure 6.42 Example of Burst ROM Access Timing**

### 6.8.3 Wait Control

As with the basic bus interface, either program wait insertion or pin wait insertion using the  $\overline{WAIT}$  pin can be used in the initial cycle (full access) of the burst ROM interface.

Wait states cannot be inserted in a burst cycle.



## 6.9 Idle Cycle

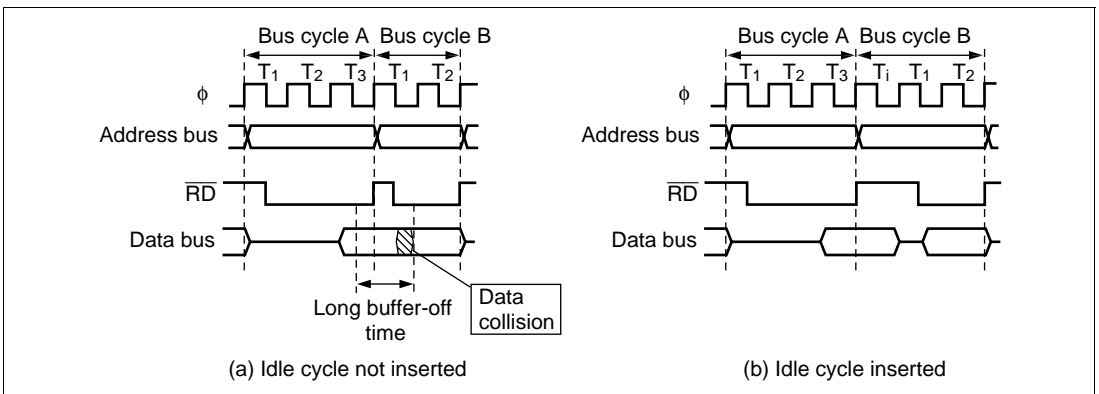
### 6.9.1 Operation

When the H8/3067 Series chip accesses external space, it can insert a 1-state idle cycle ( $T_1$ ) between bus cycles in the following cases: (1) when read accesses between different areas occur consecutively, (2) when a write cycle occurs immediately after a read cycle, and (3) immediately after a DRAM space access. By inserting an idle cycle it is possible, for example, to avoid data collisions between ROM, which has a long output floating time, and high-speed memory, I/O interfaces, and so on.

The ICIS1 and ICIS0 bits in BCR both have an initial value of 1, so that an idle cycle is inserted in the initial state. If there are no data collisions, the ICIS bits can be cleared.

**Consecutive Reads between Different Areas:** If consecutive reads between different areas occur while the ICIS1 bit is set to 1 in BCR, an idle cycle is inserted at the start of the second read cycle.

Figure 6.43 shows an example of the operation in this case. In this example, bus cycle A is a read cycle from ROM with a long output floating time, and bus cycle B is a read cycle from SRAM, each being located in a different area. In (a), an idle cycle is not inserted, and a collision occurs in cycle B between the read data from ROM and that from SRAM. In (b), an idle cycle is inserted, and a data collision is prevented.

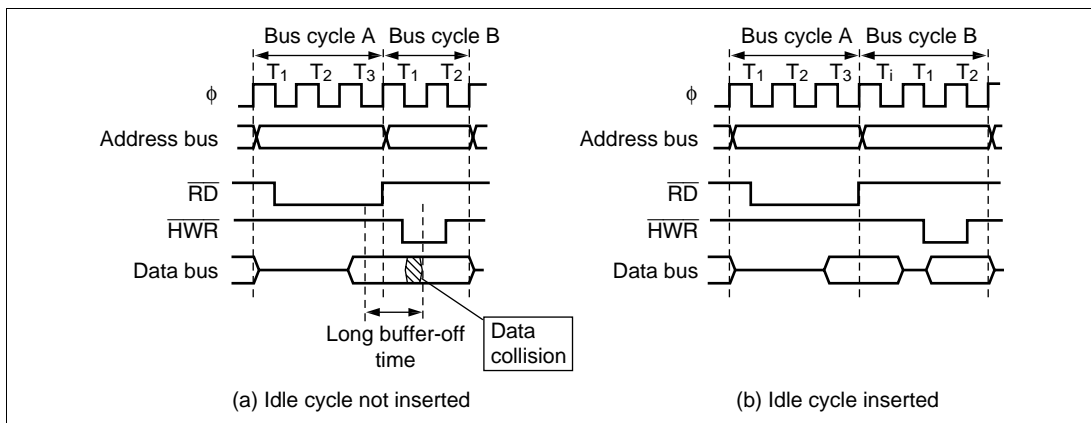


**Figure 6.43 Example of Idle Cycle Operation (1) (ICIS1 = 1)**

**Write after Read:** If an external write occurs after an external read while the ICIS0 bit is set to 1 in BCR, an idle cycle is inserted at the start of the write cycle.

Figure 6.44 shows an example of the operation in this case. In this example, bus cycle A is a read cycle from ROM with a long output floating time, and bus cycle B is a CPU write cycle.

In (a), an idle cycle is not inserted, and a collision occurs in cycle B between the read data from ROM and the CPU write data. In (b), an idle cycle is inserted, and a data collision is prevented.



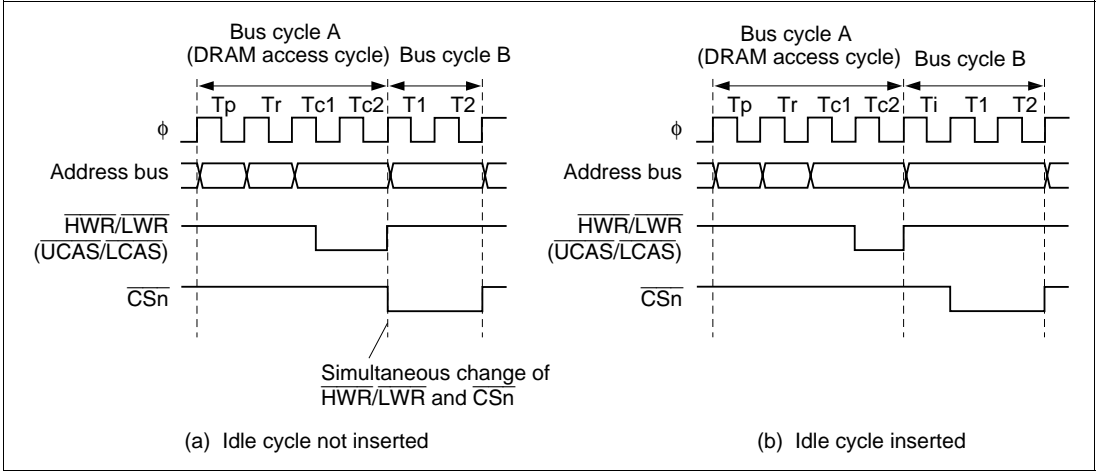
**Figure 6.44 Example of Idle Cycle Operation (2) (ICIS0 = 1)**

**External Address Space Access Immediately after DRAM Space Access:** If a DRAM space access is followed by a non-DRAM external access when  $\overline{HWR}$  and  $\overline{LWR}$  have been selected as the  $\overline{UCAS}$  and  $\overline{LCAS}$  output pins by means of the CSEL bit in DRCRB, a T<sub>i</sub> cycle is inserted regardless of the settings of bits ICIS0 and ICIS1 in BCR. Figure 6.45 shows an example of the operation.

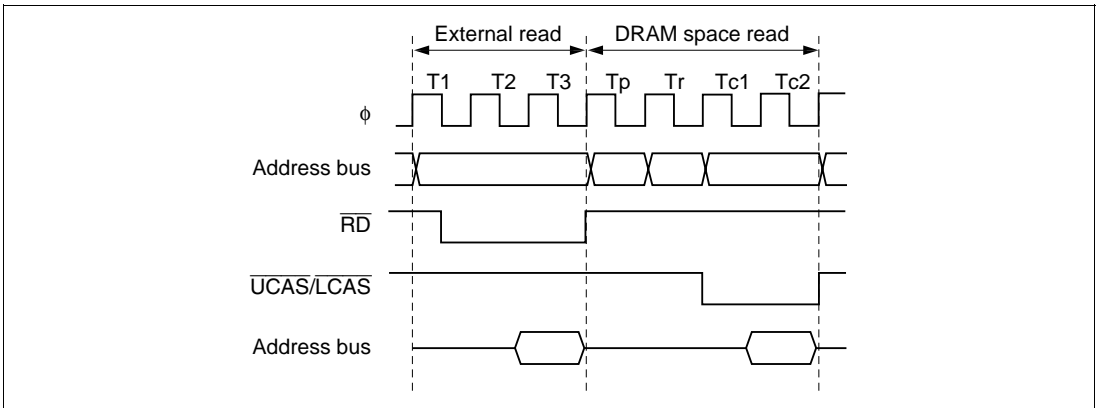
This is done to prevent simultaneous changing of the  $\overline{HWR}$  and  $\overline{LWR}$  signals used as  $\overline{UCAS}$  and  $\overline{LCAS}$  in DRAM space and  $\overline{CSn}$  for the space in the next cycle, and so avoid an erroneous write to the external device in the next cycle.

A T<sub>i</sub> cycle is not inserted when PB4 and PB5 have been selected as the  $\overline{UCAS}$  and  $\overline{LCAS}$  output pins.

In the case of consecutive DRAM space access precharge cycles (T<sub>p</sub>), the ICIS0 and ICIS1 bit settings are invalid. In the case of consecutive reads between different areas, for example, if the second access is a DRAM access, only a T<sub>p</sub> cycle is inserted, and a T<sub>i</sub> cycle is not. The timing in this case is shown in figure 6.46.



**Figure 6.45 Example of Idle Cycle Operation (3) ( $\overline{\text{HWR/LWR}}$  Used as  $\overline{\text{UCAS/LCAS}}$ )**

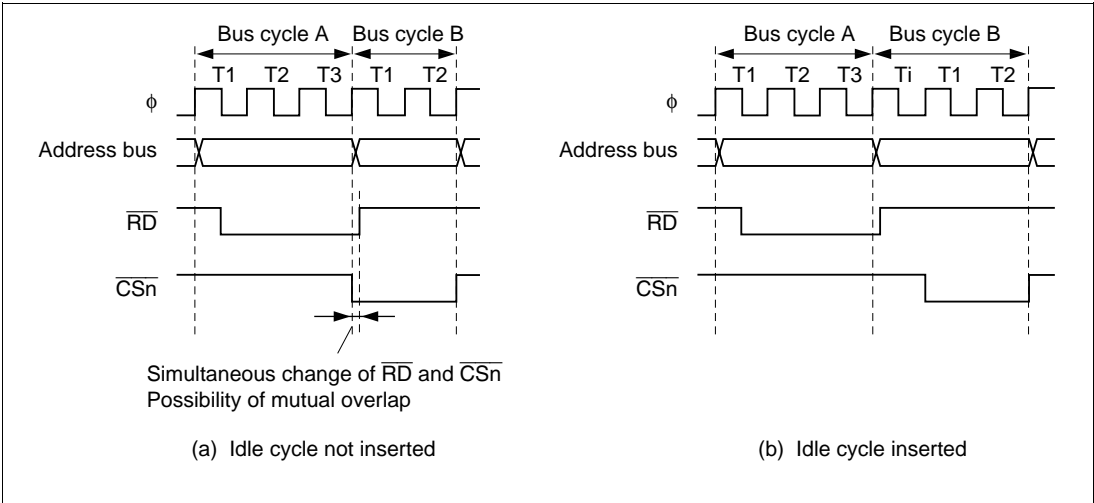


**Figure 6.46 Example of Idle Cycle Operation (4) (Consecutive Precharge Cycles)**

**Usage Notes:** When non-insertion of idle cycles is set, the rise (negation) of  $\overline{\text{RD}}$  and the fall (assertion) of  $\overline{\text{CSn}}$  may occur simultaneously. An example of the operation is shown in figure 6.47.

If consecutive reads between different external areas occur while the ICIS1 bit is cleared to 0 in BCR, or if a write cycle to a different external area occurs after an external read while the ICIS0 bit is cleared to 0, the  $\overline{\text{RD}}$  negation in the first read cycle and the  $\overline{\text{CSn}}$  assertion in the following bus cycle will occur simultaneously. Therefore, depending on the output delay time of each signal, it is possible that the low-level output of  $\overline{\text{RD}}$  in the preceding read cycle and the low-level output of  $\overline{\text{CSn}}$  in the following bus cycle will overlap.

A setting whereby idle cycle insertion is not performed can be made only when  $\overline{\text{RD}}$  and  $\overline{\text{CSn}}$  do not change simultaneously, or when it does not matter if they do.



**Figure 6.47 Example of Idle Cycle Operation (5)**

### 6.9.2 Pin States in Idle Cycle

Table 6.11 shows the pin states in an idle cycle.

**Table 6.11 Pin States in Idle Cycle**

Pins	Pin State
$A_{23}$ to $A_0$	Next cycle address value
$D_{15}$ to $D_0$	High impedance
$\overline{CSn}$	High*
$\overline{UCAS}$ , $\overline{LCAS}$	High
$\overline{AS}$	High
$\overline{RD}$	High
$\overline{HWR}$	High
$\overline{LWR}$	High

Note: \* Remains low in DRAM space RAS down mode.

## 6.10 Bus Arbiter

The bus controller has a built-in bus arbiter that arbitrates between different bus masters. There are four bus masters: the CPU, DMA controller (DMAC), DRAM interface, and an external bus master. When a bus master has the bus right it can carry out read, write, or refresh access. Each bus master uses a bus request signal to request the bus right. At fixed times the bus arbiter determines priority and uses a bus acknowledge signal to grant the bus to a bus master, which can then operate using the bus.

The bus arbiter checks whether the bus request signal from a bus master is active or inactive, and returns an acknowledge signal to the bus master. When two or more bus masters request the bus, the highest-priority bus master receives an acknowledge signal. The bus master that receives an acknowledge signal can continue to use the bus until the acknowledge signal is deactivated.

The bus master priority order is:

(High)            External bus master > DRAM interface > DMAC > CPU            (Low)

The bus arbiter samples the bus request signals and determines priority at all times, but it does not always grant the bus immediately, even when it receives a bus request from a bus master with higher priority than the current bus master. Each bus master has certain times at which it can release the bus to a higher-priority bus master.

### 6.10.1 Operation

**CPU:** The CPU is the lowest-priority bus master. If the DMAC, DRAM interface, or an external bus master requests the bus while the CPU has the bus right, the bus arbiter transfers the bus right to the bus master that requested it. The bus right is transferred at the following times:

- The bus right is transferred at the boundary of a bus cycle. If word data is accessed by two consecutive byte accesses, however, the bus right is not transferred between the two byte accesses.
- If another bus master requests the bus while the CPU is performing internal operations, such as executing a multiply or divide instruction, the bus right is transferred immediately. The CPU continues its internal operations.
- If another bus master requests the bus while the CPU is in sleep mode, the bus right is transferred immediately.

**DMAC:** When the DMAC receives an activation request, it requests the bus right from the bus arbiter. If the DMAC is bus master and the DRAM interface or an external bus master requests the bus, the bus arbiter transfers the bus right from the DMAC to the bus master that requested the bus. The bus right is transferred at the following times.

The bus right is transferred when the DMAC finishes transferring one byte or one word. A DMAC transfer cycle consists of a read cycle and a write cycle. The bus right is not transferred between the read cycle and the write cycle.

There is a priority order among the DMAC channels. For details see section 7.4.9, Multiple-Channel Operation.

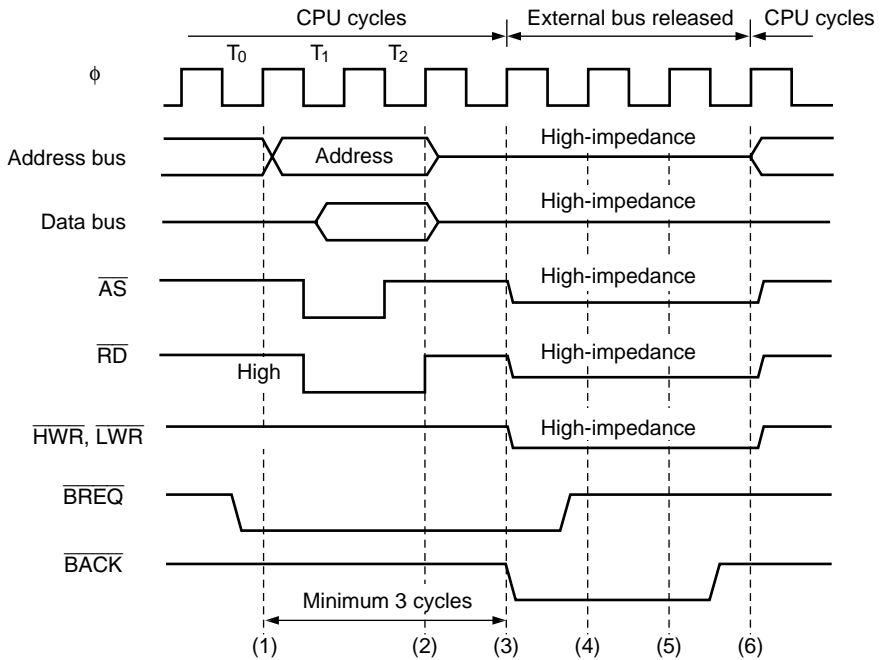
**DRAM Interface:** The DRAM interface requests the bus right from the bus arbiter when a refresh cycle request is issued, and releases the bus at the end of the refresh cycle. For details see section 6.5, DRAM Interface.

**External Bus Master:** When the BRLE bit is set to 1 in BRCR, the bus can be released to an external bus master. The external bus master has highest priority, and requests the bus right from the bus arbiter by driving the  $\overline{\text{BREQ}}$  signal low. Once the external bus master acquires the bus, it keeps the bus until the  $\overline{\text{BREQ}}$  signal goes high. While the bus is released to an external bus master, the H8/3067 Series chip holds the address bus, data bus, bus control signals ( $\overline{\text{AS}}$ ,  $\overline{\text{RD}}$ ,  $\overline{\text{HWR}}$ , and  $\overline{\text{LWR}}$ ), and chip select signals ( $\overline{\text{CSn}}$ : n = 7 to 0) in the high-impedance state, and holds the  $\overline{\text{BACK}}$  pin in the low output state.

The bus arbiter samples the  $\overline{\text{BREQ}}$  pin at the rise of the system clock ( $\phi$ ). If  $\overline{\text{BREQ}}$  is low, the bus is released to the external bus master at the appropriate opportunity. The  $\overline{\text{BREQ}}$  signal should be held low until the  $\overline{\text{BACK}}$  signal goes low.

When the  $\overline{\text{BREQ}}$  pin is high in two consecutive samples, the  $\overline{\text{BACK}}$  pin is driven high to end the bus-release cycle.

Figure 6.48 shows the timing when the bus right is requested by an external bus master during a read cycle in a two-state access area. There is a minimum interval of three states from when the  $\overline{\text{BREQ}}$  signal goes low until the bus is released.



**Figure 6.48 Example of External Bus Master Operation**

In the event of contention with a bus request from an external bus master when a transition is made to software standby mode, the  $\overline{BACK}$  and strobe states may be indeterminate after the transition to software standby mode (see figure 6.36).

When software standby mode is used, the BRLE bit should be cleared to 0 in BRCCR before executing the SLEEP instruction.

## 6.11 Register and Pin Input Timing

### 6.11.1 Register Write Timing

**ABWCR, ASTCR, WCRH, and WCRL Write Timing:** Data written to ABWCR, ASTCR, WCRH, and WCRL takes effect starting from the next bus cycle. Figure 6.49 shows the timing when an instruction fetched from area 0 changes area 0 from three-state access to two-state access.

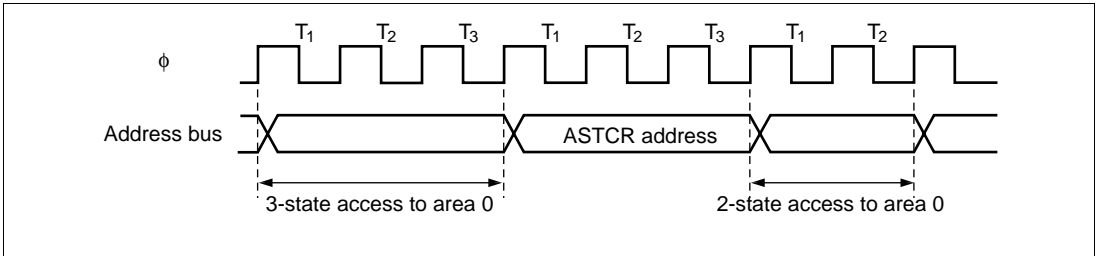


Figure 6.49 ASTCR Write Timing

**DDR and CSCR Write Timing:** Data written to DDR or CSCR for the port corresponding to the  $\overline{CS}_n$  pin to switch between  $\overline{CS}_n$  output and generic input takes effect starting from the  $T_3$  state of the DDR write cycle. Figure 6.50 shows the timing when the  $\overline{CS}_1$  pin is changed from generic input to  $\overline{CS}_1$  output.

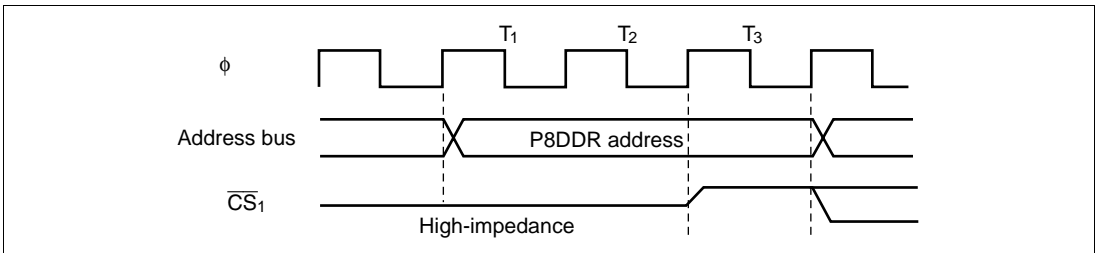
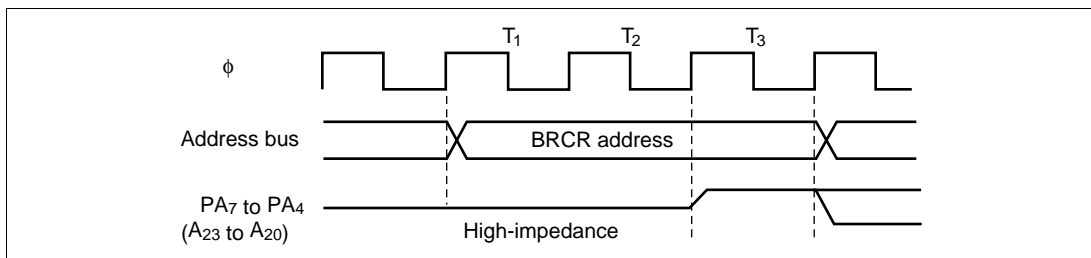


Figure 6.50 DDR Write Timing



**BRCR Write Timing:** Data written to BRCR to switch between  $A_{23}$ ,  $A_{22}$ ,  $A_{21}$ , or  $A_{20}$  output and generic input or output takes effect starting from the  $T_3$  state of the BRCR write cycle. Figure 6.51 shows the timing when a pin is changed from generic input to  $A_{23}$ ,  $A_{22}$ ,  $A_{21}$ , or  $A_{20}$  output.



**Figure 6.51 BRCR Write Timing**

### 6.11.2 $\overline{\text{BREQ}}$ Pin Input Timing

After driving the  $\overline{\text{BREQ}}$  pin low, hold it low until  $\overline{\text{BACK}}$  goes low. If  $\overline{\text{BREQ}}$  returns to the high level before  $\overline{\text{BACK}}$  goes low, the bus arbiter may operate incorrectly.

To terminate the external-bus-released state, hold the  $\overline{\text{BREQ}}$  signal high for at least three states. If  $\overline{\text{BREQ}}$  is high for too short an interval, the bus arbiter may operate incorrectly.



# Section 7 DMA Controller

## 7.1 Overview

The H8/3067 Series has an on-chip DMA controller (DMAC) that can transfer data on up to four channels.

When the DMA controller is not used, it can be independently halted to conserve power. For details see section 20.6, Module Standby Function.

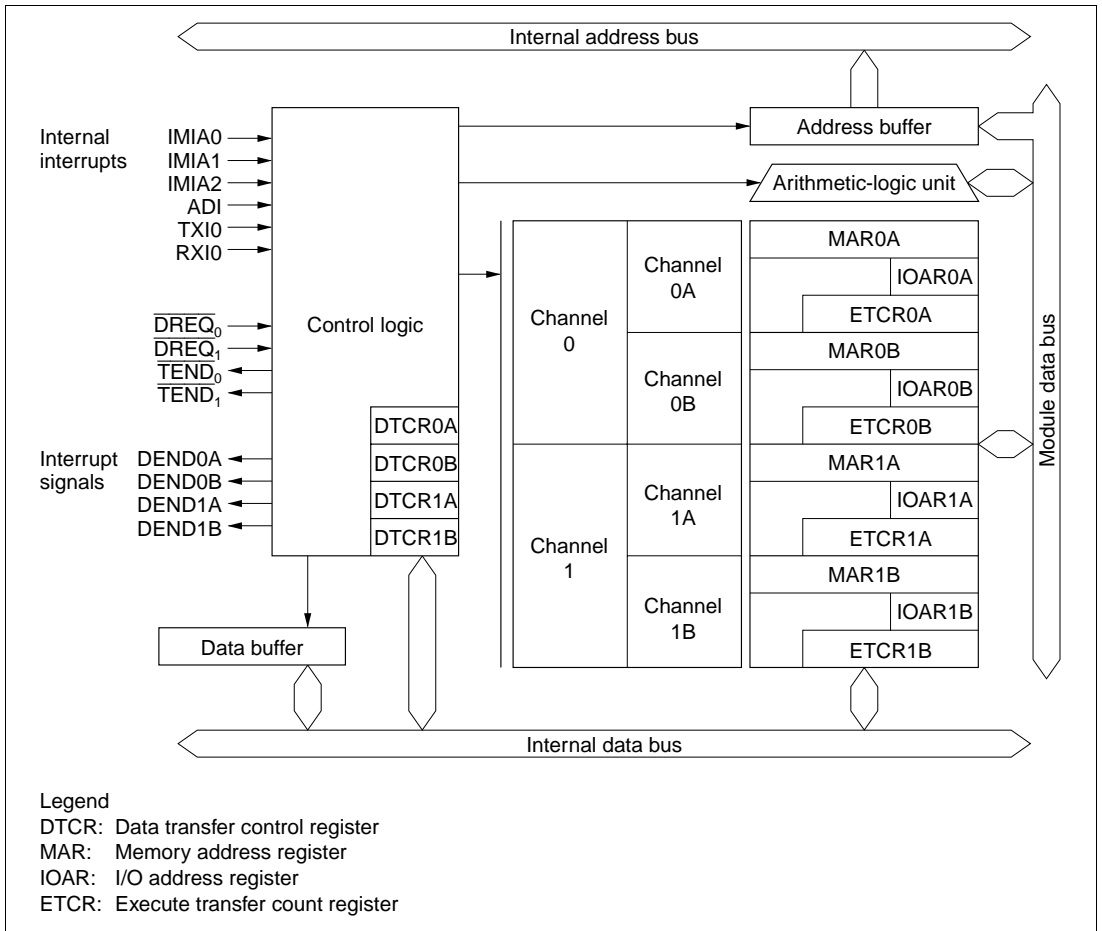
### 7.1.1 Features

DMAC features are listed below.

- Selection of short address mode or full address mode
  - Short address mode
    - 8-bit source address and 24-bit destination address, or vice versa
    - Maximum four channels available
    - Selection of I/O mode, idle mode, or repeat mode
  - Full address mode
    - 24-bit source and destination addresses
    - Maximum two channels available
    - Selection of normal mode or block transfer mode
- Directly addressable 16-Mbyte address space
- Selection of byte or word transfer
- Activation by internal interrupts, external requests, or auto-request (depending on transfer mode)
  - 16-bit timer compare match/input capture interrupts (×3)
  - Serial communication interface (SCI channel 0) transmit-data-empty/receive-data-full interrupts
  - External requests
  - Auto-request
  - A/D converter conversion-end interrupt

## 7.1.2 Block Diagram

Figure 7.1 shows a DMAC block diagram.



**Figure 7.1 Block Diagram of DMAC**

### 7.1.3 Functional Overview

Table 7.1 gives an overview of the DMAC functions.

**Table 7.1 DMAC Functional Overview**

Transfer Mode		Activation	Address Reg. Length	
			Source	Destination
Short address mode	I/O mode <ul style="list-style-type: none"> <li>Transfers one byte or one word per request</li> <li>Increments or decrements the memory address by 1 or 2</li> <li>Executes 1 to 65,536 transfers</li> </ul>	<ul style="list-style-type: none"> <li>Compare match/input capture A interrupts from 16-bit timer channels 0 to 2</li> <li>Transmit-data-empty interrupt from SCI channel 0</li> </ul>	24	8
	Idle mode <ul style="list-style-type: none"> <li>Transfers one byte or one word per request</li> <li>Holds the memory address fixed</li> <li>Executes 1 to 65,536 transfers</li> </ul>	<ul style="list-style-type: none"> <li>Conversion-end interrupt from A/D converter</li> <li>Receive-data-full interrupt from SCI channel 0</li> </ul>	8	24
	Repeat mode <ul style="list-style-type: none"> <li>Transfers one byte or one word per request</li> <li>Increments or decrements the memory address by 1 or 2</li> <li>Executes a specified number (1 to 255) of transfers, then returns to the initial state and continues</li> </ul>	<ul style="list-style-type: none"> <li>External request</li> </ul>	24	8
Full address mode	Normal mode <ul style="list-style-type: none"> <li>Auto-request               <ul style="list-style-type: none"> <li>Retains the transfer request internally</li> <li>Executes a specified number(1 to 65,536) of transfers continuously</li> <li>Selection of burst mode or cycle-steal mode</li> </ul> </li> <li>External request               <ul style="list-style-type: none"> <li>Transfers one byte or one word per request</li> <li>Executes 1 to 65,536 transfers</li> </ul> </li> </ul>	<ul style="list-style-type: none"> <li>Auto-request</li> <li>External request</li> </ul>	24	24
	Block transfer <ul style="list-style-type: none"> <li>Transfers one block of a specified size per request</li> <li>Executes 1 to 65,536 transfers</li> <li>Allows either the source or destination to be a fixed block area</li> <li>Block size can be 1 to 255 bytes or words</li> </ul>	<ul style="list-style-type: none"> <li>Compare match/ input capture A interrupts from 16-bit timer channels 0 to 2</li> <li>External request</li> <li>Conversion-end interrupt from A/D converter</li> </ul>	24	24

### 7.1.4 Input/Output Pins

Table 7.2 lists the DMAC pins.

**Table 7.2 DMAC Pins**

Channel	Name	Abbreviation	Input/Output	Function
0	DMA request 0	$\overline{\text{DREQ}}_0$	Input	External request for DMAC channel 0
	Transfer end 0	$\overline{\text{TEND}}_0$	Output	Transfer end on DMAC channel 0
1	DMA request 1	$\overline{\text{DREQ}}_1$	Input	External request for DMAC channel 1
	Transfer end 1	$\overline{\text{TEND}}_1$	Output	Transfer end on DMAC channel 1

Note: External requests cannot be made to channel A in short address mode.

### 7.1.5 Register Configuration

Table 7.3 lists the DMAC registers.

**Table 7.3 DMAC Registers**

<b>Channel</b>	<b>Address*</b>	<b>Name</b>	<b>Abbreviation</b>	<b>R/W</b>	<b>Initial Value</b>
0	H'FFF20	Memory address register 0AR	MAR0AR	R/W	Undetermined
	H'FFF21	Memory address register 0AE	MAR0AE	R/W	Undetermined
	H'FFF22	Memory address register 0AH	MAR0AH	R/W	Undetermined
	H'FFF23	Memory address register 0AL	MAR0AL	R/W	Undetermined
	H'FFF26	I/O address register 0A	IOAR0A	R/W	Undetermined
	H'FFF24	Execute transfer count register 0AH	ETCR0AH	R/W	Undetermined
	H'FFF25	Execute transfer count register 0AL	ETCR0AL	R/W	Undetermined
	H'FFF27	Data transfer control register 0A	DTCR0A	R/W	H'00
	H'FFF28	Memory address register 0BR	MAR0BR	R/W	Undetermined
	H'FFF29	Memory address register 0BE	MAR0BE	R/W	Undetermined
	H'FFF2A	Memory address register 0BH	MAR0BH	R/W	Undetermined
	H'FFF2B	Memory address register 0BL	MAR0BL	R/W	Undetermined
	H'FFF2E	I/O address register 0B	IOAR0B	R/W	Undetermined
	H'FFF2C	Execute transfer count register 0BH	ETCR0BH	R/W	Undetermined
	H'FFF2D	Execute transfer count register 0BL	ETCR0BL	R/W	Undetermined
	H'FFF2F	Data transfer control register 0B	DTCR0B	R/W	H'00
	1	H'FFF30	Memory address register 1AR	MAR1AR	R/W
H'FFF31		Memory address register 1AE	MAR1AE	R/W	Undetermined
H'FFF32		Memory address register 1AH	MAR1AH	R/W	Undetermined
H'FFF33		Memory address register 1AL	MAR1AL	R/W	Undetermined
H'FFF36		I/O address register 1A	IOAR1A	R/W	Undetermined
H'FFF34		Execute transfer count register 1AH	ETCR1AH	R/W	Undetermined
H'FFF35		Execute transfer count register 1AL	ETCR1AL	R/W	Undetermined
H'FFF37		Data transfer control register 1A	DTCR1A	R/W	H'00
H'FFF38		Memory address register 1BR	MAR1BR	R/W	Undetermined
H'FFF39		Memory address register 1BE	MAR1BE	R/W	Undetermined
H'FFF3A		Memory address register 1BH	MAR1BH	R/W	Undetermined
H'FFF3B		Memory address register 1BL	MAR1BL	R/W	Undetermined
H'FFF3E		I/O address register 1B	IOAR1B	R/W	Undetermined
H'FFF3C		Execute transfer count register 1BH	ETCR1BH	R/W	Undetermined
H'FFF3D		Execute transfer count register 1BL	ETCR1BL	R/W	Undetermined
H'FFF3F		Data transfer control register 1B	DTCR1B	R/W	H'00

Note: \* The lower 20 bits of the address are indicated.

## 7.2 Register Descriptions (1) (Short Address Mode)

In short address mode, transfers can be carried out independently on channels A and B. Short address mode is selected by bits DTS2A and DTS1A in data transfer control register A (DTCRA) as indicated in table 7.4.

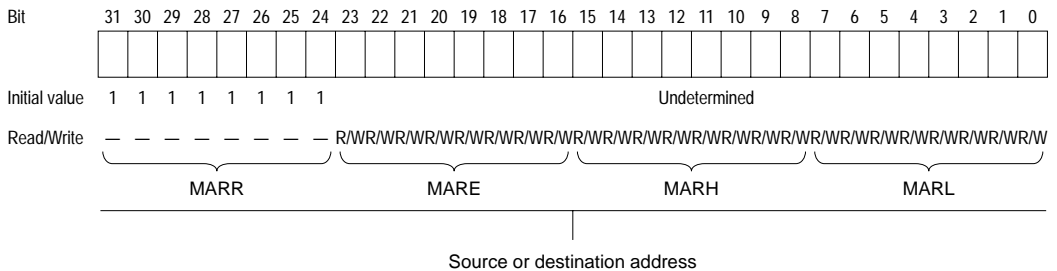
**Table 7.4 Selection of Short and Full Address Modes**

Channel	Bit 2 DTS2A	Bit 1 DTS1A	Description
0	1	1	DMAC channel 0 operates as one channel in full address mode
	Other than above		DMAC channels 0A and 0B operate as two independent channels in short address mode
1	1	1	DMAC channel 1 operates as one channel in full address mode
	Other than above		DMAC channels 1A and 1B operate as two independent channels in short address mode

### 7.2.1 Memory Address Registers (MAR)

A memory address register (MAR) is a 32-bit readable/writable register that specifies a source or destination address. The transfer direction is determined automatically from the activation source.

An MAR consists of four 8-bit registers designated MARR, MARE, MARH, and MARL. All bits of MARR are reserved; they cannot be modified and are always read as 1.



An MAR functions as a source or destination address register depending on how the DMAC is activated: as a destination address register if activation is by a receive-data-full interrupt from serial communication interface (SCI) channel 0 or by an A/D converter conversion-end interrupt, and as a source address register otherwise.

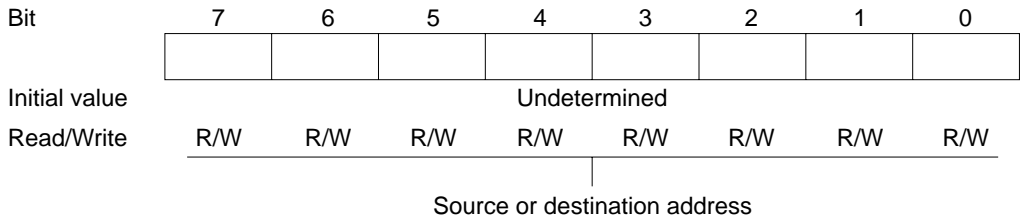
The MAR value is incremented or decremented each time one byte or word is transferred, automatically updating the source or destination memory address. For details, see section 7.3.4, Data Transfer Control Registers (DTCR).

The MARs are not initialized by a reset or in standby mode.



## 7.2.2 I/O Address Registers (IOAR)

An I/O address register (IOAR) is an 8-bit readable/writable register that specifies a source or destination address. The IOAR value is the lower 8 bits of the address. The upper 16 address bits are all 1 (H'FFFF).



An IOAR functions as a source or destination address register depending on how the DMAC is activated: as a destination address register if activation is by a receive-data-full interrupt from serial communication interface (SCI) channel 0 or by an A/D converter conversion-end interrupt, and as a source address register otherwise.

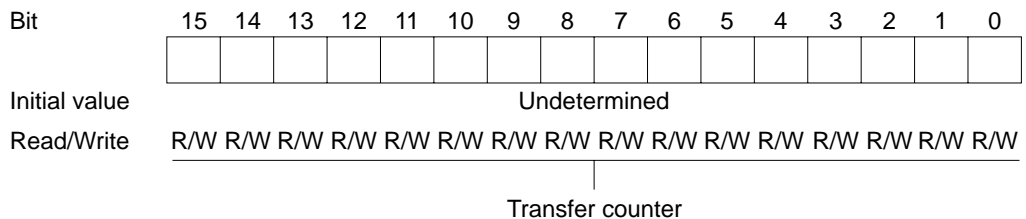
The IOAR value is held fixed. It is not incremented or decremented when a transfer is executed.

The IOARs are not initialized by a reset or in standby mode.

## 7.2.3 Execute Transfer Count Registers (ETCR)

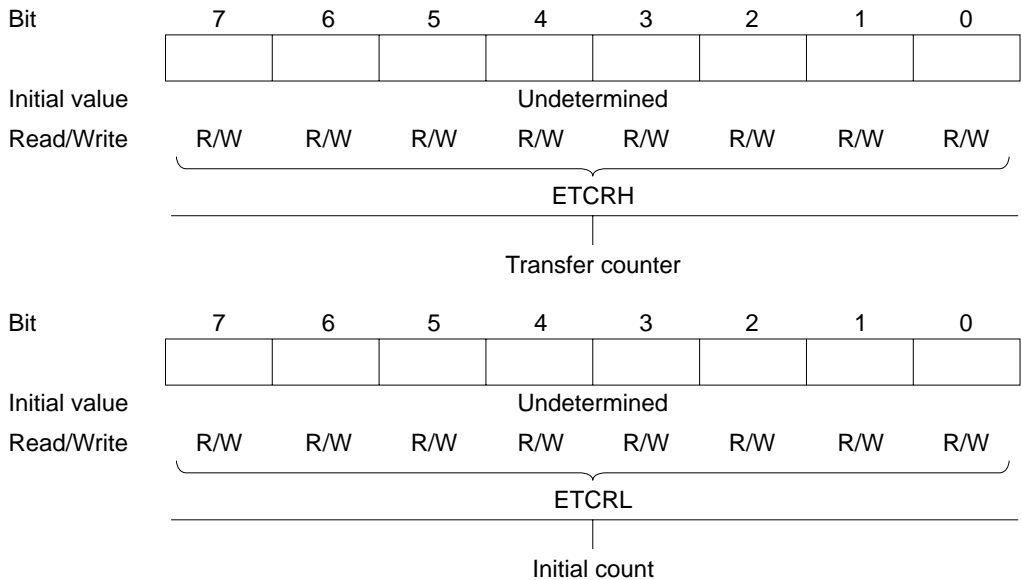
An execute transfer count register (ETCR) is a 16-bit readable/writable register that specifies the number of transfers to be executed. These registers function in one way in I/O mode and idle mode, and another way in repeat mode.

- I/O mode and idle mode



In I/O mode and idle mode, ETCR functions as a 16-bit counter. The count is decremented by 1 each time one transfer is executed. The transfer ends when the count reaches H'0000.

- Repeat mode

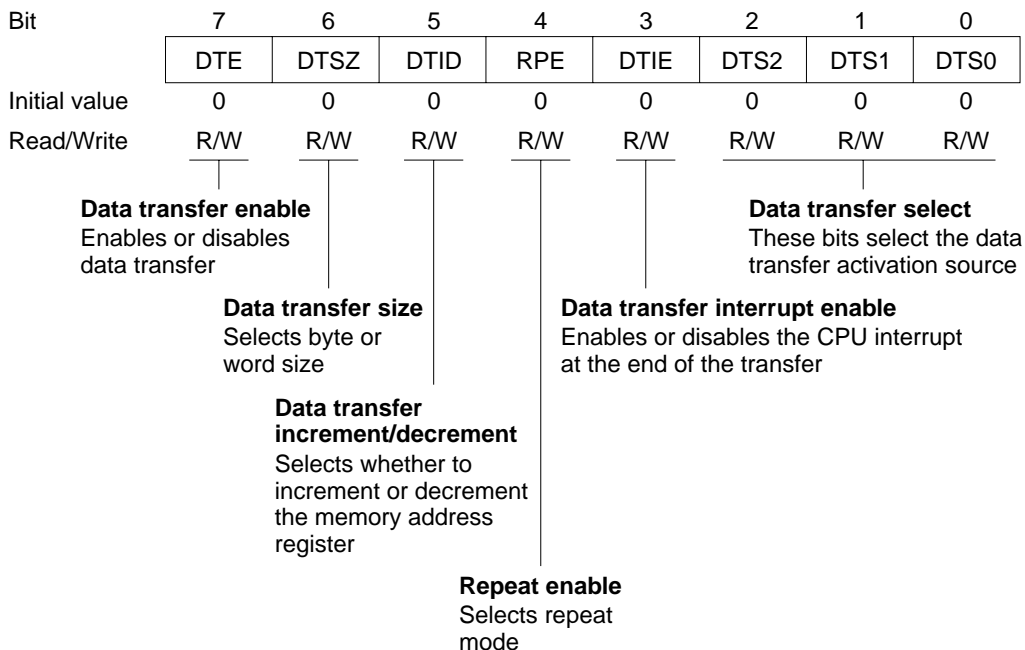


In repeat mode, ETCRH functions as an 8-bit transfer counter and ETCRL holds the initial transfer count. ETCRH is decremented by 1 each time one transfer is executed. When ETCRH reaches H'00, the value in ETCRL is reloaded into ETCRH and the same operation is repeated.

The ETCRs are not initialized by a reset or in standby mode.

## 7.2.4 Data Transfer Control Registers (DTCR)

A data transfer control register (DTCR) is an 8-bit readable/writable register that controls the operation of one DMAC channel.



The DTCRs are initialized to H'00 by a reset and in standby mode.

**Bit 7—Data Transfer Enable (DTE):** Enables or disables data transfer on a channel. When the DTE bit is set to 1, the channel waits for a transfer to be requested, and executes the transfer when activated as specified by bits DTS2 to DTS0. When DTE is 0, the channel is disabled and does not accept transfer requests. DTE is set to 1 by reading the register when DTE is 0, then writing 1.

### Bit 7

DTE	Description
0	Data transfer is disabled. In I/O mode or idle mode, DTE is cleared to 0 (Initial value) when the specified number of transfers have been completed
1	Data transfer is enabled

If DTIE is set to 1, a CPU interrupt is requested when DTIE is cleared to 0.

**Bit 6—Data Transfer Size (DTSZ):** Selects the data size of each transfer.

**Bit 6**

DTSZ	Description	
0	Byte-size transfer	(Initial value)
1	Word-size transfer	

**Bit 5—Data Transfer Increment/Decrement (DTID):** Selects whether to increment or decrement the memory address register (MAR) after a data transfer in I/O mode or repeat mode.

**Bit 5**

DTID	Description	
0	MAR is incremented after each data transfer	(Initial value)
	<ul style="list-style-type: none"><li>If DTSZ = 0, MAR is incremented by 1 after each transfer</li><li>If DTSZ = 1, MAR is incremented by 2 after each transfer</li></ul>	
1	MAR is decremented after each data transfer	
	<ul style="list-style-type: none"><li>If DTSZ = 0, MAR is decremented by 1 after each transfer</li><li>If DTSZ = 1, MAR is decremented by 2 after each transfer</li></ul>	

MAR is not incremented or decremented in idle mode.

**Bit 4—Repeat Enable (RPE):** Selects whether to transfer data in I/O mode, idle mode, or repeat mode.

Bit 4 RPE	Bit 3 DTIE	Description	
0	0	I/O mode	(Initial value)
	1		
1	0	Repeat mode	
	1	Idle mode	

Operations in these modes are described in sections 7.4.2, I/O Mode, 7.4.3, Idle Mode, and 7.4.4, Repeat Mode.

**Bit 3—Data Transfer Interrupt Enable (DTIE):** Enables or disables the CPU interrupt (DEND) requested when the DTE bit is cleared to 0.

**Bit 3**

DTIE	Description
0	The DEND interrupt requested by DTE is disabled (Initial value)
1	The DEND interrupt requested by DTE is enabled

**Bits 2 to 0—Data Transfer Select (DTS2, DTS1, DTS0):** These bits select the data transfer activation source. Some of the selectable sources differ between channels A and B.

Bit 2 DTS2	Bit 1 DTS1	Bit 0 DTS0	Description
0	0	0	Compare match/input capture A interrupt from 16-bit timer (Initial value) channel 0
		1	Compare match/input capture A interrupt from 16-bit timer channel 1
	1	0	Compare match/input capture A interrupt from 16-bit timer channel 2
		1	Conversion-end interrupt from A/D converter
1	0	0	Transmit-data-empty interrupt from SCI channel 0
		1	Receive-data-full interrupt from SCI channel 0
	1	0	Falling edge of $\overline{\text{DREQ}}$ input (channel B) Transfer in full address mode (channel A)
		1	Low level of $\overline{\text{DREQ}}$ input (channel B) Transfer in full address mode (channel A)

Note: \* See section 7.3.4, Data Transfer Control Registers (DTCR).

The same internal interrupt can be selected as an activation source for two or more channels at once. In that case the channels are activated in a priority order, highest-priority channel first. For the priority order, see section 7.4.9, Multiple-Channel Operation.

When a channel is enabled (DTE = 1), its selected DMAC activation source cannot generate a CPU interrupt.

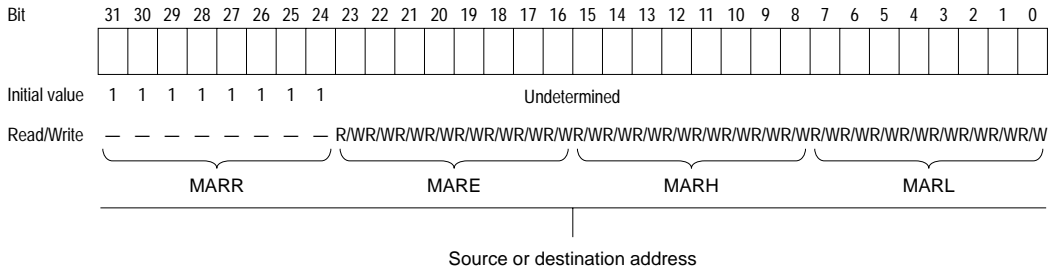
## 7.3 Register Descriptions (2) (Full Address Mode)

In full address mode the A and B channels operate together. Full address mode is selected as indicated in table 7.4.

### 7.3.1 Memory Address Registers (MAR)

A memory address register (MAR) is a 32-bit readable/writable register. MARA functions as the source address register of the transfer, and MARB as the destination address register.

An MAR consists of four 8-bit registers designated MARR, MARE, MARH, and MARL. All bits of MARR are reserved; they cannot be modified and are always read as 1. (Write is invalid.)



The MAR value is incremented or decremented each time one byte or word is transferred, automatically updating the source or destination memory address. For details, see section 7.3.4, Data Transfer Control Registers (DTCR).

The MARs are not initialized by a reset or in standby mode.

### 7.3.2 I/O Address Registers (IOAR)

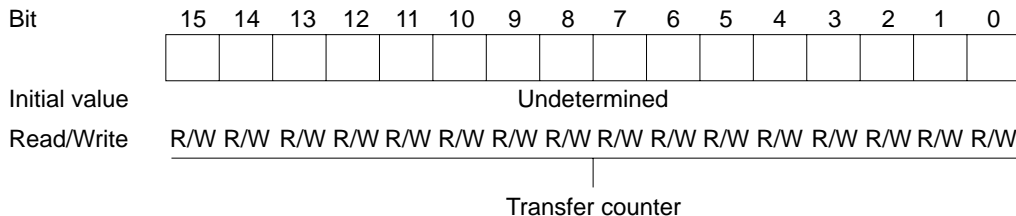
The I/O address registers (IOARs) are not used in full address mode.

### 7.3.3 Execute Transfer Count Registers (ETCR)

An execute transfer count register (ETCR) is a 16-bit readable/writable register that specifies the number of transfers to be executed. The functions of these registers differ between normal mode and block transfer mode.

- Normal mode

#### ETCRA

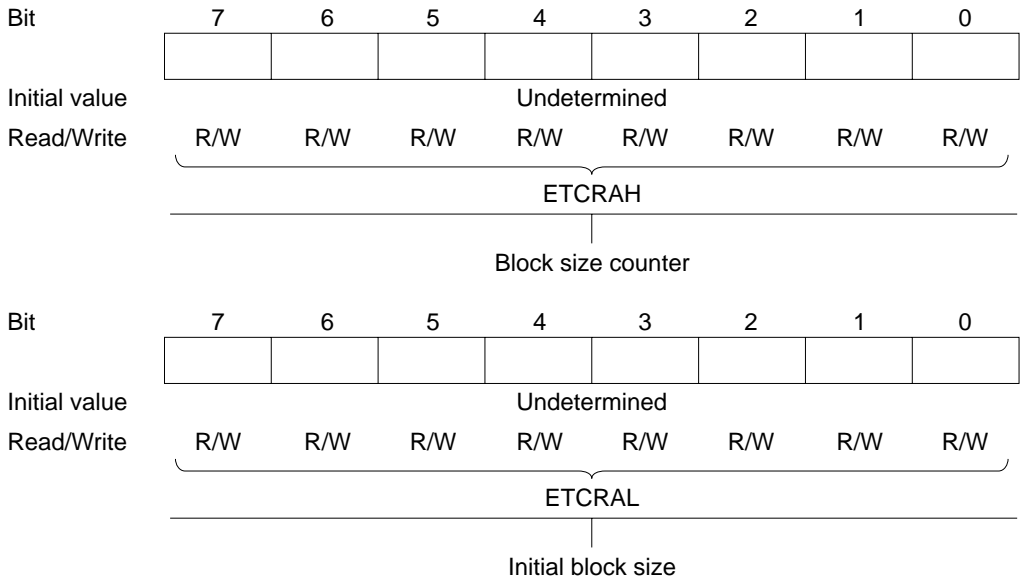


ETCRB: Is not used in normal mode.

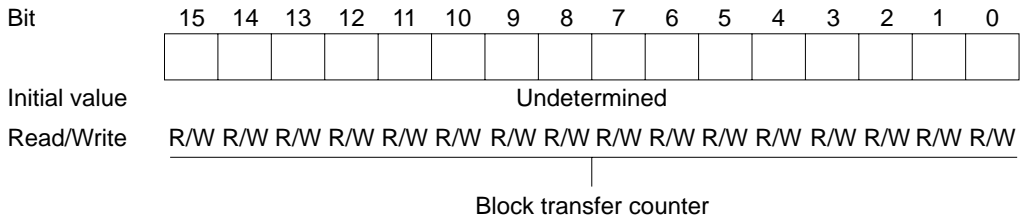
In normal mode ETCRA functions as a 16-bit transfer counter. The count is decremented by 1 each time one transfer is executed. The transfer ends when the count reaches H'0000. ETCRB is not used.

- Block transfer mode

## ETCRA



## ETCRB



In block transfer mode, ETCRAH functions as an 8-bit block size counter. ETCRAL holds the initial block size. ETCRAH is decremented by 1 each time one byte or word is transferred. When the count reaches H'00, ETCRAH is reloaded from ETCRAL. Blocks consisting of an arbitrary number of bytes or words can be transferred repeatedly by setting the same initial block size value in ETCRAH and ETCRAL.

In block transfer mode ETCRB functions as a 16-bit block transfer counter. ETCRB is decremented by 1 each time one block is transferred. The transfer ends when the count reaches H'0000.

The ETCRs are not initialized by a reset or in standby mode.



### 7.3.4 Data Transfer Control Registers (DTCR)

The data transfer control registers (DTCRs) are 8-bit readable/writable registers that control the operation of the DMAC channels. A channel operates in full address mode when bits DTS2A and DTS1A are both set to 1 in DTCRA. DTCRA and DTCRB have different functions in full address mode.

#### DTCRA

Bit	7	6	5	4	3	2	1	0
	DTE	DTSZ	SAID	SAIDE	DTIE	DTS2A	DTS1A	DTS0A
Initial value	0	0	0	0	0	0	0	0
Read/Write	R/W	R/W	R/W	R/W	R/W	R/W	R/W	R/W

<p><b>Data transfer enable</b> Enables or disables data transfer</p>	<p><b>Data transfer size</b> Selects byte or word size</p>	<p><b>Source address increment/decrement</b> <b>Source address increment/decrement enable</b> These bits select whether the source address register (MARA) is incremented, decremented, or held fixed during the data transfer</p>	<p><b>Data transfer interrupt enable</b> Enables or disables the CPU interrupt at the end of the transfer</p>	<p><b>Data transfer select 0A</b> Selects block transfer mode</p> <p><b>Data transfer select 2A and 1A</b> These bits must both be set to 1</p>
--	--	--	---	---

DTCRA is initialized to H'00 by a reset and in standby mode.

**Bit 7—Data Transfer Enable (DTE):** Together with the DTME bit in DTCRB, this bit enables or disables data transfer on the channel. When the DTME and DTE bits are both set to 1, the channel is enabled. If auto-request is specified, data transfer begins immediately. Otherwise, the channel waits for transfers to be requested. When the specified number of transfers have been completed, the DTE bit is automatically cleared to 0. When DTE is 0, the channel is disabled and does not accept transfer requests. DTE is set to 1 by reading the register when DTE is 0, then writing 1.

**Bit 7**

DTE	Description
0	Data transfer is disabled (DTE is cleared to 0 when the specified number of transfers have been completed) (Initial value)
1	Data transfer is enabled

If DTIE is set to 1, a CPU interrupt is requested when DTE is cleared to 0.

**Bit 6—Data Transfer Size (DTSZ):** Selects the data size of each transfer.

**Bit 6**

DTSZ	Description
0	Byte-size transfer (Initial value)
1	Word-size transfer

**Bit 5—Source Address Increment/Decrement (SAID) and,**

**Bit 4—Source Address Increment/Decrement Enable (SAIDE):** These bits select whether the source address register (MARA) is incremented, decremented, or held fixed during the data transfer.

Bit 5 SAID	Bit 4 SAIDE	Description
0	0	MARA is held fixed (Initial value)
	1	MARA is incremented after each data transfer <ul style="list-style-type: none"> <li>If DTSZ = 0, MARA is incremented by 1 after each transfer</li> <li>If DTSZ = 1, MARA is incremented by 2 after each transfer</li> </ul>
1	0	MARA is held fixed
	1	MARA is decremented after each data transfer <ul style="list-style-type: none"> <li>If DTSZ = 0, MARA is decremented by 1 after each transfer</li> <li>If DTSZ = 1, MARA is decremented by 2 after each transfer</li> </ul>

**Bit 3—Data Transfer Interrupt Enable (DTIE):** Enables or disables the CPU interrupt (DEND) requested when the DTE bit is cleared to 0.

**Bit 3**

<b>DTIE</b>	<b>Description</b>
0	The DEND interrupt requested by DTE is disabled (Initial value)
1	The DEND interrupt requested by DTE is enabled

**Bits 2 and 1—Data Transfer Select 2A and 1A (DTS2A, DTS1A):** A channel operates in full address mode when DTS2A and DTS1A are both set to 1.

**Bit 0—Data Transfer Select 0A (DTS0A):** Selects normal mode or block transfer mode.

**Bit 0**

<b>DTS0A</b>	<b>Description</b>
0	Normal mode (Initial value)
1	Block transfer mode

Operations in these modes are described in sections 7.4.5, Normal Mode, and 7.4.6, Block Transfer Mode.

## DTCRB

Bit	7	6	5	4	3	2	1	0
	DTME	—	DAID	DAIDE	TMS	DTS2B	DTS1B	DTS0B
Initial value	0	0	0	0	0	0	0	0
Read/Write	R/W	R/W	R/W	R/W	R/W	R/W	R/W	R/W

**Data transfer master enable**  
Enables or disables data transfer, together with the DTE bit, and is cleared to 0 by an interrupt

**Reserved bit**

**Transfer mode select**  
Selects whether the block area is the source or destination in block transfer mode

**Destination address increment/decrement**  
**Destination address increment/decrement enable**  
These bits select whether the destination address register (MARB) is incremented, decremented, or held fixed during the data transfer

**Data transfer select 2B to 0B**  
These bits select the data transfer activation source

DTCRB is initialized to H'00 by a reset and in standby mode.

**Bit 7—Data Transfer Master Enable (DTME):** Together with the DTE bit in DTCRA, this bit enables or disables data transfer. When the DTME and DTE bits are both set to 1, the channel is enabled. When an NMI interrupt occurs DTME is cleared to 0, suspending the transfer so that the CPU can use the bus. The suspended transfer resumes when DTME is set to 1 again. For further information on operation in block transfer mode, see section 7.6.6, NMI Interrupts and Block Transfer Mode.

DTME is set to 1 by reading the register while DTME = 0, then writing 1.

### Bit 7

DTME	Description
0	Data transfer is disabled (DTME is cleared to 0 when an NMI interrupt occurs) (Initial value)
1	Data transfer is enabled

**Bit 6—Reserved:** Although reserved, this bit can be written and read.

**Bit 5—Destination Address Increment/Decrement (DAID) and,**

**Bit 4—Destination Address Increment/Decrement Enable (DAIDE):** These bits select whether the destination address register (MARB) is incremented, decremented, or held fixed during the data transfer.

Bit 5 DAID	Bit 4 DAIDE	Description
0	0	MARB is held fixed (Initial value)
	1	MARB is incremented after each data transfer <ul style="list-style-type: none"><li>If DTSZ = 0, MARB is incremented by 1 after each data transfer</li><li>If DTSZ = 1, MARB is incremented by 2 after each data transfer</li></ul>
1	0	MARB is held fixed
	1	MARB is decremented after each data transfer <ul style="list-style-type: none"><li>If DTSZ = 0, MARB is decremented by 1 after each data transfer</li><li>If DTSZ = 1, MARB is decremented by 2 after each data transfer</li></ul>

**Bit 3—Transfer Mode Select (TMS):** Selects whether the source or destination is the block area in block transfer mode.

Bit 3 TMS	Description
0	Destination is the block area in block transfer mode (Initial value)
1	Source is the block area in block transfer mode

**Bits 2 to 0—Data Transfer Select 2B to 0B (DTS2B, DTS1B, DTS0B):** These bits select the data transfer activation source. The selectable activation sources differ between normal mode and block transfer mode.

Normal mode

Bit 2 DTS2B	Bit 1 DTS1B	Bit 0 DTS0B	Description
0	0	0	Auto-request (burst mode) (Initial value)
		1	Cannot be used
	1	0	Auto-request (cycle-steal mode)
		1	Cannot be used
1	0	0	Cannot be used
		1	Cannot be used
	1	0	Falling edge of $\overline{\text{DREQ}}$
		1	Low level input at $\overline{\text{DREQ}}$

Block transfer mode

Bit 2 DTS2B	Bit 1 DTS1B	Bit 0 DTS0B	Description
0	0	0	Compare match/input capture A interrupt from 16-bit timer channel 0 (Initial value)
		1	Compare match/input capture A interrupt from 16-bit timer channel 1
	1	0	Compare match/input capture A interrupt from 16-bit timer channel 2
		1	Conversion-end interrupt from A/D converter
1	0	0	Cannot be used
		1	Cannot be used
	1	0	Falling edge of $\overline{\text{DREQ}}$
		1	Cannot be used

The same internal interrupt can be selected to activate two or more channels. The channels are activated in a priority order, highest priority first. For the priority order, see section 7.4.9, Multiple-Channel Operation.

## 7.4 Operation

### 7.4.1 Overview

Table 7.5 summarizes the DMAC modes.

**Table 7.5 DMAC Modes**

Transfer Mode		Activation	Notes
Short address mode	I/O mode	Compare match/input capture A interrupt from 16-bit timer channels 0 to 2	• Up to four channels can operate independently
	Idle mode	Transmit-data-empty and receive-data-full interrupts from SCI channel 0	
	Repeat mode	Conversion-end interrupt from A/D converter	
		External request	
Full address mode	Normal mode	Auto-request	• A and B channels are paired; up to two channels are available
		External request	
	Block transfer mode	Compare match/input capture A interrupt from 16-bit timer channels 0 to 2	• Burst mode transfer or cycle-steal mode transfer can be selected for auto-requests
		Conversion-end interrupt from A/D converter	
	External request		

A summary of operations in these modes follows.

**I/O Mode:** One byte or word is transferred per request. A designated number of these transfers are executed. A CPU interrupt can be requested at completion of the designated number of transfers. One 24-bit address and one 8-bit address are specified. The transfer direction is determined automatically from the activation source.

**Idle Mode:** One byte or word is transferred per request. A designated number of these transfers are executed. A CPU interrupt can be requested at completion of the designated number of

transfers. One 24-bit address and one 8-bit address are specified. The addresses are held fixed. The transfer direction is determined automatically from the activation source.

**Repeat Mode:** One byte or word is transferred per request. A designated number of these transfers are executed. When the designated number of transfers are completed, the initial address and counter value are restored and operation continues. No CPU interrupt is requested. One 24-bit address and one 8-bit address are specified. The transfer direction is determined automatically from the activation source.

## Normal Mode

- Auto-request

The DMAC is activated by register setup alone, and continues executing transfers until the designated number of transfers have been completed. A CPU interrupt can be requested at completion of the transfers. Both addresses are 24-bit addresses.

- Cycle-steal mode

The bus is released to another bus master after each byte or word is transferred.

- Burst mode

Unless requested by a higher-priority bus master, the bus is not released until the designated number of transfers have been completed.

- External request

One byte or word is transferred per request. A designated number of these transfers are executed. A CPU interrupt can be requested at completion of the designated number of transfers. Both addresses are 24-bit addresses.

**Block Transfer Mode:** One block of a specified size is transferred per request. A designated number of block transfers are executed. At the end of each block transfer, one address is restored to its initial value. When the designated number of blocks have been transferred, a CPU interrupt can be requested. Both addresses are 24-bit addresses.



## 7.4.2 I/O Mode

I/O mode can be selected independently for each channel.

One byte or word is transferred at each transfer request in I/O mode. A designated number of these transfers are executed. One address is specified in the memory address register (MAR), the other in the I/O address register (IOAR). The direction of transfer is determined automatically from the activation source. The transfer is from the address specified in IOAR to the address specified in MAR if activated by an SCI channel 0 receive-data-full interrupt, and from the address specified in MAR to the address specified in IOAR otherwise.

Table 7.6 indicates the register functions in I/O mode.

**Table 7.6 Register Functions in I/O Mode**

Register	Function		Initial Setting	Operation
	Activated by SCI 0 Receive-Data-Full Interrupt	Other Activation		
<div style="display: flex; justify-content: space-between;"> <span>23</span> <span>0</span> </div> <div style="border: 1px solid black; padding: 5px; margin-top: 5px;"> <div style="display: flex; justify-content: space-between;"> <span style="width: 150px;"></span> <span>MAR</span> </div> </div>	Destination address register	Source address register	Destination or source start address	Incremented or decremented once per transfer
<div style="display: flex; justify-content: space-between;"> <span>23</span> <span>7</span> <span>0</span> </div> <div style="border: 1px solid black; padding: 5px; margin-top: 5px;"> <div style="display: flex; justify-content: space-between;"> <span style="width: 100px;">All 1s</span> <span>IOAR</span> </div> </div>	Source address register	Destination address register	Source or destination address	Held fixed
<div style="display: flex; justify-content: space-between;"> <span>15</span> <span>0</span> </div> <div style="border: 1px solid black; padding: 5px; margin-top: 5px;"> <div style="display: flex; justify-content: space-between;"> <span style="width: 100px;">ETCR</span> </div> </div>	Transfer counter		Number of transfers	Decrement once per transfer until H'0000 is reached and transfer ends

### Legend

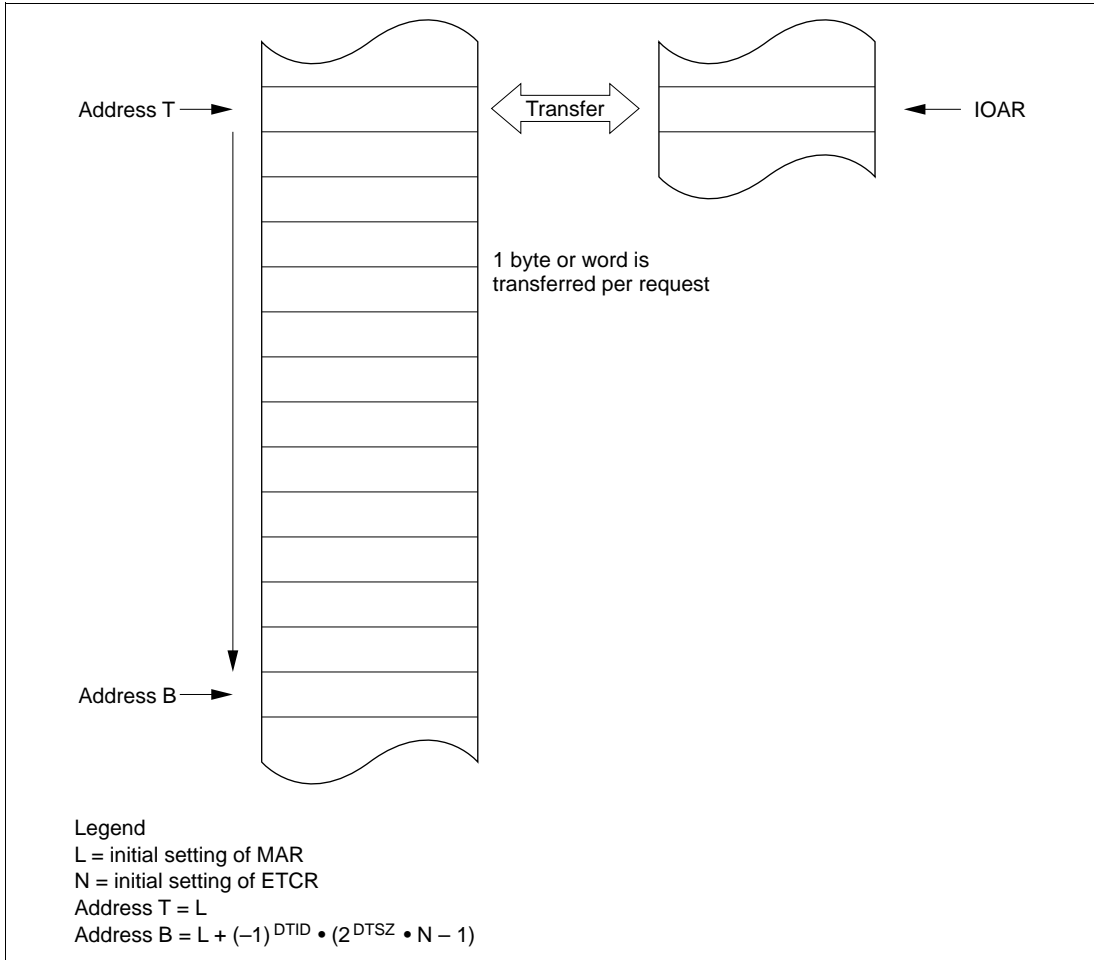
MAR: Memory address register

IOAR: I/O address register

ETCR: Execute transfer count register

MAR and IOAR specify the source and destination addresses. MAR specifies a 24-bit source or destination address, which is incremented or decremented as each byte or word is transferred. IOAR specifies the lower 8 bits of a fixed address. The upper 16 bits are all 1s. IOAR is not incremented or decremented.

Figure 7.2 illustrates how I/O mode operates.



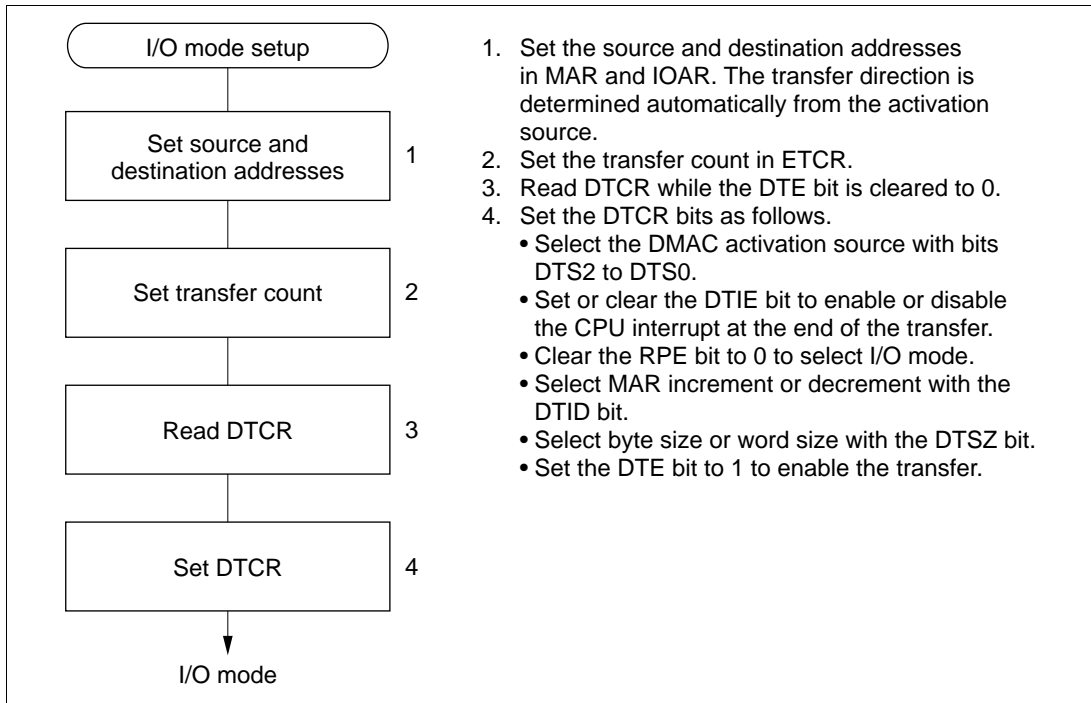
**Figure 7.2 Operation in I/O Mode**

The transfer count is specified as a 16-bit value in ETCR. The ETCR value is decremented by 1 at each transfer. When the ETCR value reaches H'0000, the DTE bit is cleared and the transfer ends. If the DTIE bit is set to 1, a CPU interrupt is requested at this time. The maximum transfer count is 65,536, obtained by setting ETCR to H'0000.

Transfers can be requested (activated) by compare match/input capture A interrupts from 16-bit timer channels 0 to 2, transmit-data-empty and receive-data-full interrupts from SCI channel 0, conversion-end interrupts from the A/D converter, and external request signals.

For the detailed settings see section 7.2.4, Data Transfer Control Registers (DTCR).

Figure 7.3 shows a sample setup procedure for I/O mode.



**Figure 7.3 I/O Mode Setup Procedure (Example)**




### 7.4.3 Idle Mode

Idle mode can be selected independently for each channel.

One byte or word is transferred at each transfer request in idle mode. A designated number of these transfers are executed. One address is specified in the memory address register (MAR), the other in the I/O address register (IOAR). The direction of transfer is determined automatically from the activation source. The transfer is from the address specified in IOAR to the address specified in MAR if activated by an SCI channel 0 receive-data-full interrupt, and from the address specified in MAR to the address specified in IOAR otherwise.

Table 7.7 indicates the register functions in idle mode.

**Table 7.7 Register Functions in Idle Mode**

Register	Function		Initial Setting	Operation
	Activated by SCI 0 Receive- Data-Full Interrupt	Other Activation		
23 	Destination address register	Source address register	Destination or source address	Held fixed
23 	Source address register	Destination address register	Source or destination address	Held fixed
15 	Transfer counter		Number of transfers	Decremented once per transfer until H'0000 is reached and transfer ends

**Legend**

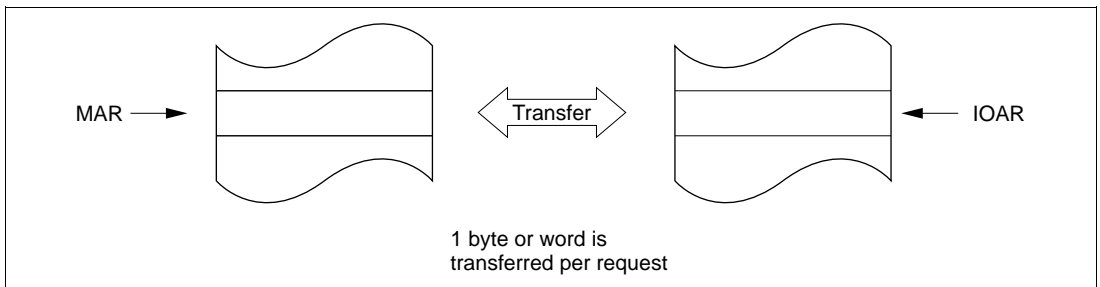
MAR: Memory address register

IOAR: I/O address register

ETCR: Execute transfer count register

MAR and IOAR specify the source and destination addresses. MAR specifies a 24-bit source or destination address. IOAR specifies the lower 8 bits of a fixed address. The upper 16 bits are all 1s. MAR and IOAR are not incremented or decremented.

Figure 7.4 illustrates how idle mode operates.



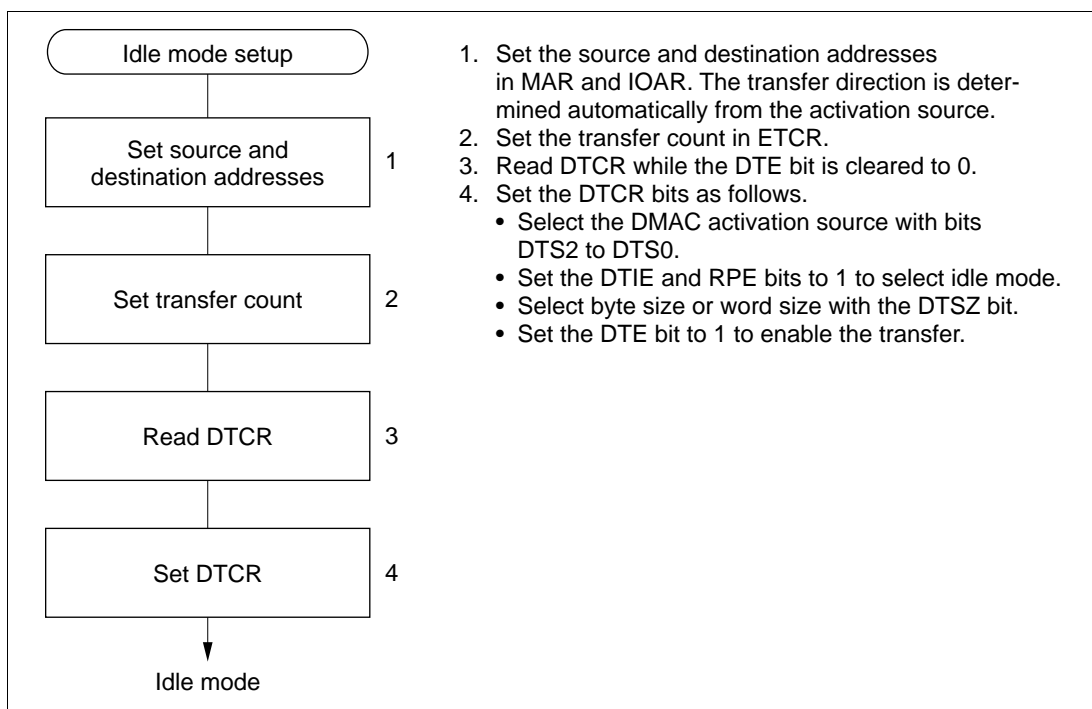
**Figure 7.4 Operation in Idle Mode**

The transfer count is specified as a 16-bit value in ETCR. The ETCR value is decremented by 1 at each transfer. When the ETCR value reaches H'0000, the DTE bit is cleared, the transfer ends, and a CPU interrupt is requested. The maximum transfer count is 65,536, obtained by setting ETCR to H'0000.

Transfers can be requested (activated) by compare match/input capture A interrupts from 16-bit timer channels 0 to 2, transmit-data-empty and receive-data-full interrupts from SCI channel 0, conversion-end interrupts from the A/D converter, and external request signals.

For the detailed settings see section 7.3.4, Data Transfer Control Registers (DTCR).

Figure 7.5 shows a sample setup procedure for idle mode.



**Figure 7.5 Idle Mode Setup Procedure (Example)**

## 7.4.4 Repeat Mode

Repeat mode is useful for cyclically transferring a bit pattern from a table to the programmable timing pattern controller (TPC) in synchronization, for example, with 16-bit timer compare match. Repeat mode can be selected for each channel independently.

One byte or word is transferred per request in repeat mode, as in I/O mode. A designated number of these transfers are executed. One address is specified in the memory address register (MAR), the other in the I/O address register (IOAR). At the end of the designated number of transfers, MAR and ETCRH are restored to their original values and operation continues. The direction of transfer is determined automatically from the activation source. The transfer is from the address specified in IOAR to the address specified in MAR if activated by an SCI channel 0 receive-data-full interrupt, and from the address specified in MAR to the address specified in IOAR otherwise.

Table 7.8 indicates the register functions in repeat mode.

**Table 7.8 Register Functions in Repeat Mode**

Register	Function		Initial Setting	Operation
	Activated by SCI 0 Receive-Data-Full Interrupt	Other Activation		
<div style="display: flex; justify-content: space-between; align-items: center;"> <span>23</span> <div style="border: 1px solid black; padding: 5px; text-align: center;"> <span style="font-size: small;">23</span> <span style="font-size: x-small; margin: 0 10px;"> </span> <span style="font-size: x-small;">MAR</span> <span style="font-size: x-small; margin: 0 10px;"> </span> <span style="font-size: small;">0</span> </div> </div>	Destination address register	Source address register	Destination or source start address	Incremented or decremented at each transfer until ETCRH reaches H'0000, then restored to initial value
<div style="display: flex; justify-content: space-between; align-items: center;"> <span>23</span> <div style="border: 1px solid black; padding: 5px; text-align: center;"> <span style="font-size: x-small;">All 1s</span> </div> <div style="border: 1px solid black; padding: 5px; text-align: center;"> <span style="font-size: small;">7</span> <span style="font-size: x-small; margin: 0 10px;"> </span> <span style="font-size: small;">0</span> </div> </div>	Source address register	Destination address register	Source or destination address	Held fixed
<div style="display: flex; justify-content: center; align-items: center;"> <div style="border: 1px solid black; padding: 5px; text-align: center;"> <span style="font-size: small;">7</span> <span style="font-size: x-small; margin: 0 10px;"> </span> <span style="font-size: small;">0</span> </div> <div style="margin: 0 10px;">ETCRH</div> </div>	Transfer counter		Number of transfers	Decrement once per transfer until H'0000 is reached, then reloaded from ETCRL
<div style="display: flex; justify-content: center; align-items: center;"> <div style="margin-bottom: 10px;">↑</div> <div style="border: 1px solid black; padding: 5px; text-align: center;"> <span style="font-size: small;">7</span> <span style="font-size: x-small; margin: 0 10px;"> </span> <span style="font-size: small;">0</span> </div> <div style="margin: 0 10px;">ETCRL</div> </div>	Initial transfer count		Number of transfers	Held fixed

### Legend

MAR: Memory address register

IOAR: I/O address register

ETCR: Execute transfer count register

In repeat mode ETCRH is used as the transfer counter while ETCRL holds the initial transfer count. ETCRH is decremented by 1 at each transfer until it reaches H'00, then is reloaded from ETCRL. MAR is also restored to its initial value, which is calculated from the DTSZ and DTID bits in DTCR. Specifically, MAR is restored as follows:

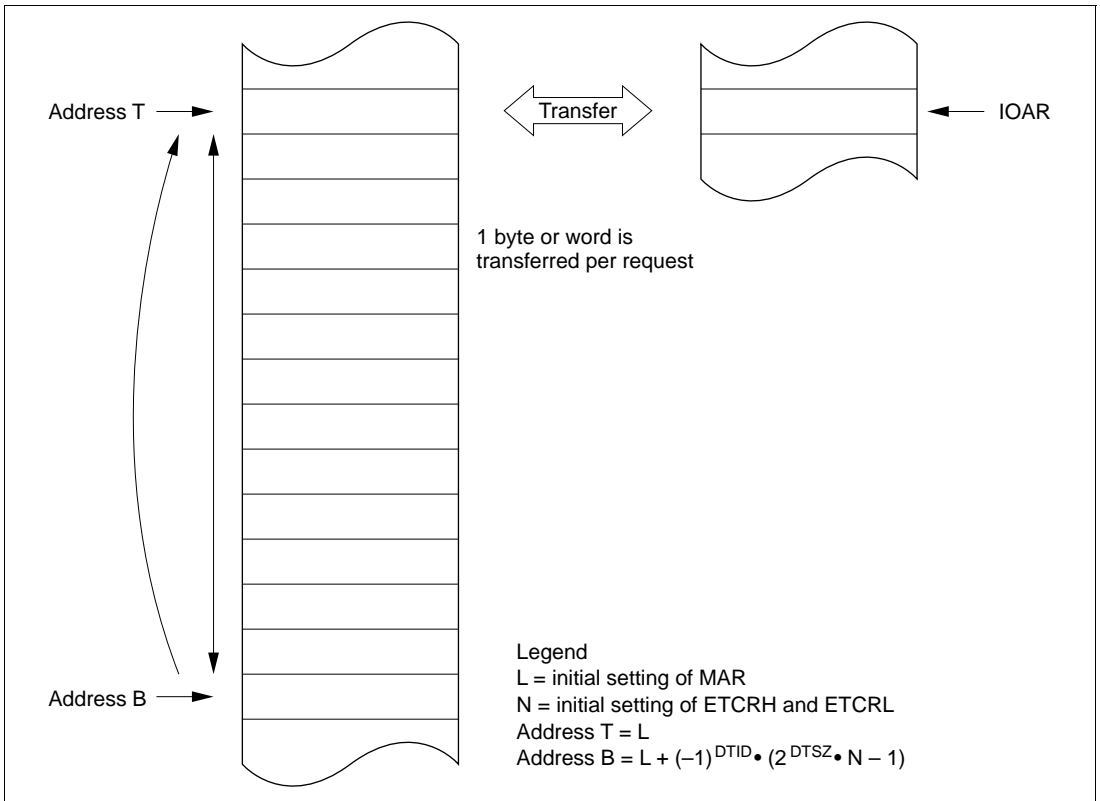
$$\text{MAR} \leftarrow \text{MAR} - (-1)^{\text{DTID}} \cdot 2^{\text{DTSZ}} \cdot \text{ETCRL}$$

ETCRH and ETCRL should be initially set to the same value.

In repeat mode transfers continue until the CPU clears the DTE bit to 0. After DTE is cleared to 0, if the CPU sets DTE to 1 again, transfers resume from the state at which DTE was cleared. No CPU interrupt is requested.

As in I/O mode, MAR and IOAR specify the source and destination addresses. MAR specifies a 24-bit source or destination address. IOAR specifies the lower 8 bits of a fixed address. The upper 16 bits are all 1s. IOAR is not incremented or decremented.

Figure 7.6 illustrates how repeat mode operates.



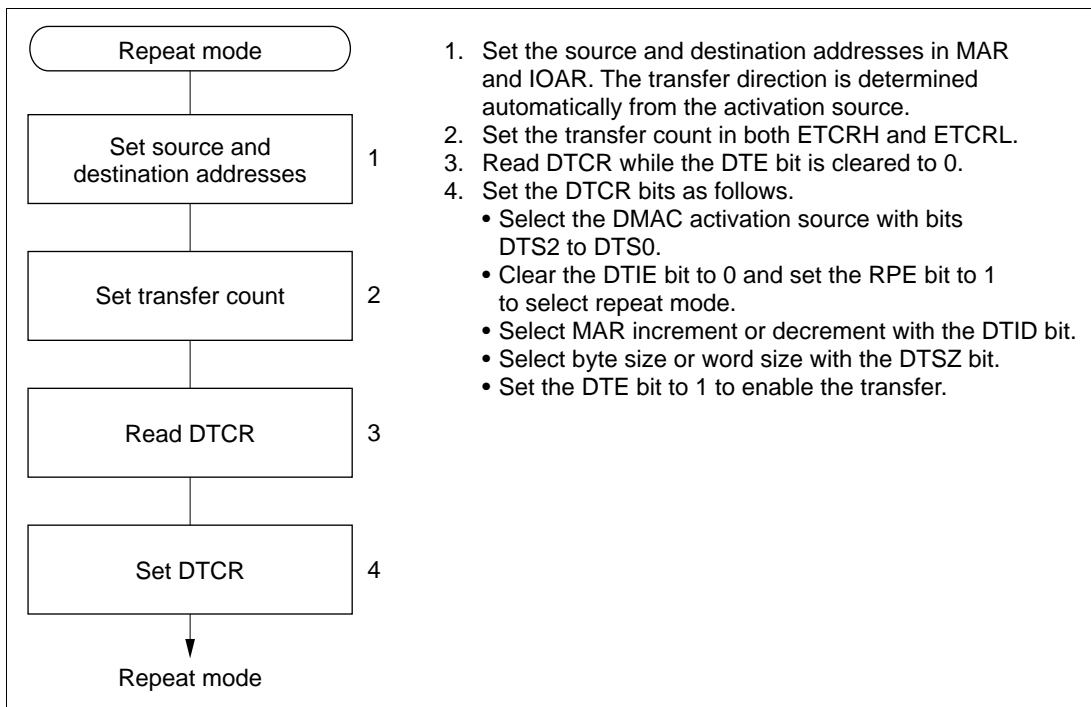
**Figure 7.6 Operation in Repeat Mode**

The transfer count is specified as an 8-bit value in ETCRH and ETCRL. The maximum transfer count is 255, obtained by setting both ETCRH and ETCRL to H'FF.

Transfers can be requested (activated) by compare match/input capture A interrupts from 16-bit timer channels 0 to 2, transmit-data-empty and receive-data-full interrupts from SCI channel 0, conversion-end interrupts from the A/D converter, and external request signals.

For the detailed settings see section 7.2.4, Data Transfer Control Registers (DTCR).

Figure 7.7 shows a sample setup procedure for repeat mode.






**Figure 7.7 Repeat Mode Setup Procedure (Example)**



## 7.4.5 Normal Mode

In normal mode the A and B channels are combined. One byte or word is transferred per request. A designated number of these transfers are executed. Addresses are specified in MARA and MARB. Table 7.9 indicates the register functions in I/O mode.

**Table 7.9 Register Functions in Normal Mode**

Register	Function	Initial Setting	Operation
23 	0 Source address register	Source start address	Incremented or decremented once per transfer, or held fixed
23 	0 Destination address register	Destination start address	Incremented or decremented once per transfer, or held fixed
15 	0 Transfer counter	Number of transfers	Decrementd once per transfer

### Legend

MARA: Memory address register A

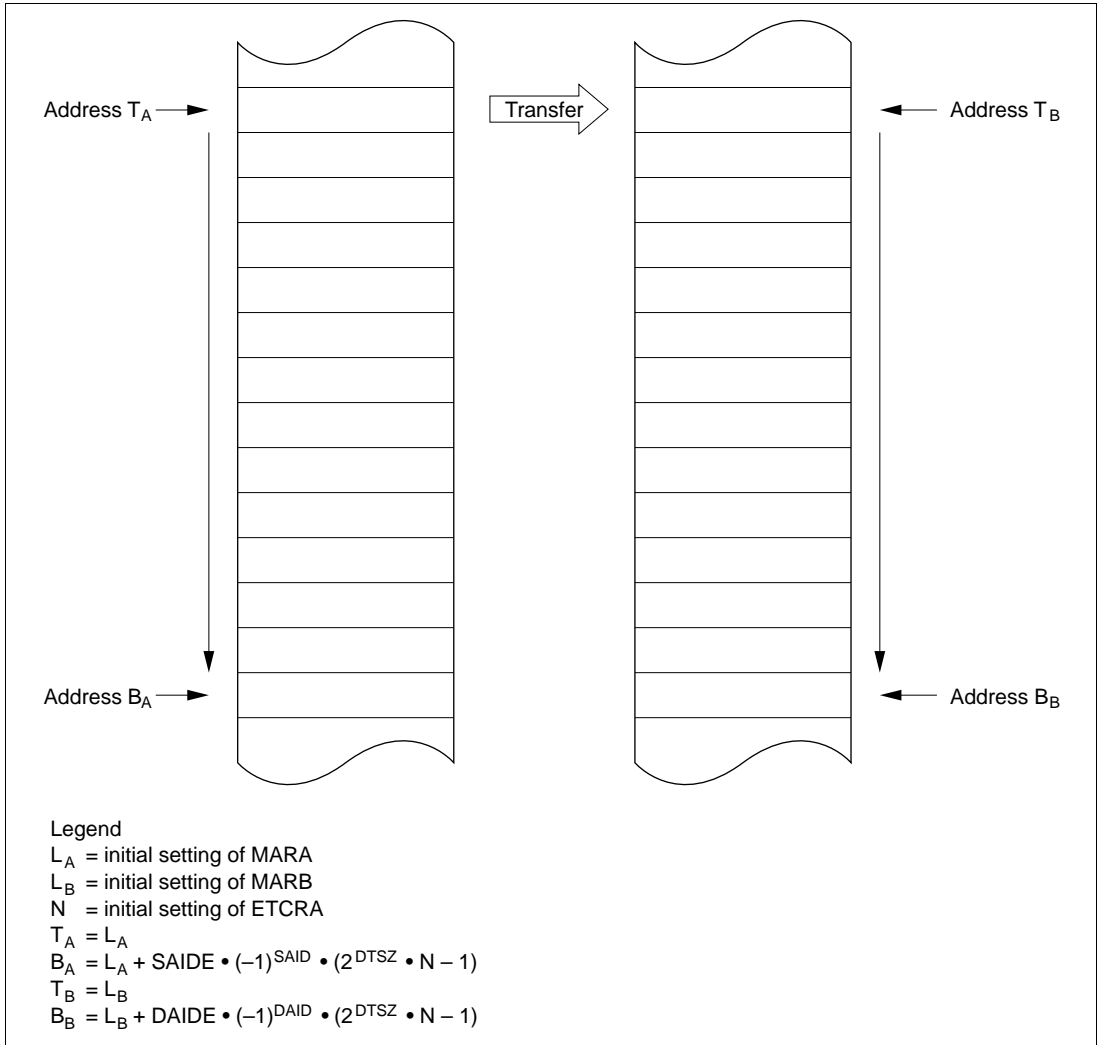
MARB: Memory address register B

ETCRA: Execute transfer count register A

The source and destination addresses are both 24-bit addresses. MARA specifies the source address. MARB specifies the destination address. MARA and MARB can be independently incremented, decremented, or held fixed as data is transferred.

The transfer count is specified as a 16-bit value in ETCRA. The ETCRA value is decremented by 1 at each transfer. When the ETCRA value reaches H'0000, the DTE bit is cleared and the transfer ends. If the DTIE bit is set to 1, a CPU interrupt is requested at this time. The maximum transfer count is 65,536, obtained by setting ETCRA to H'0000.

Figure 7.8 illustrates how normal mode operates.

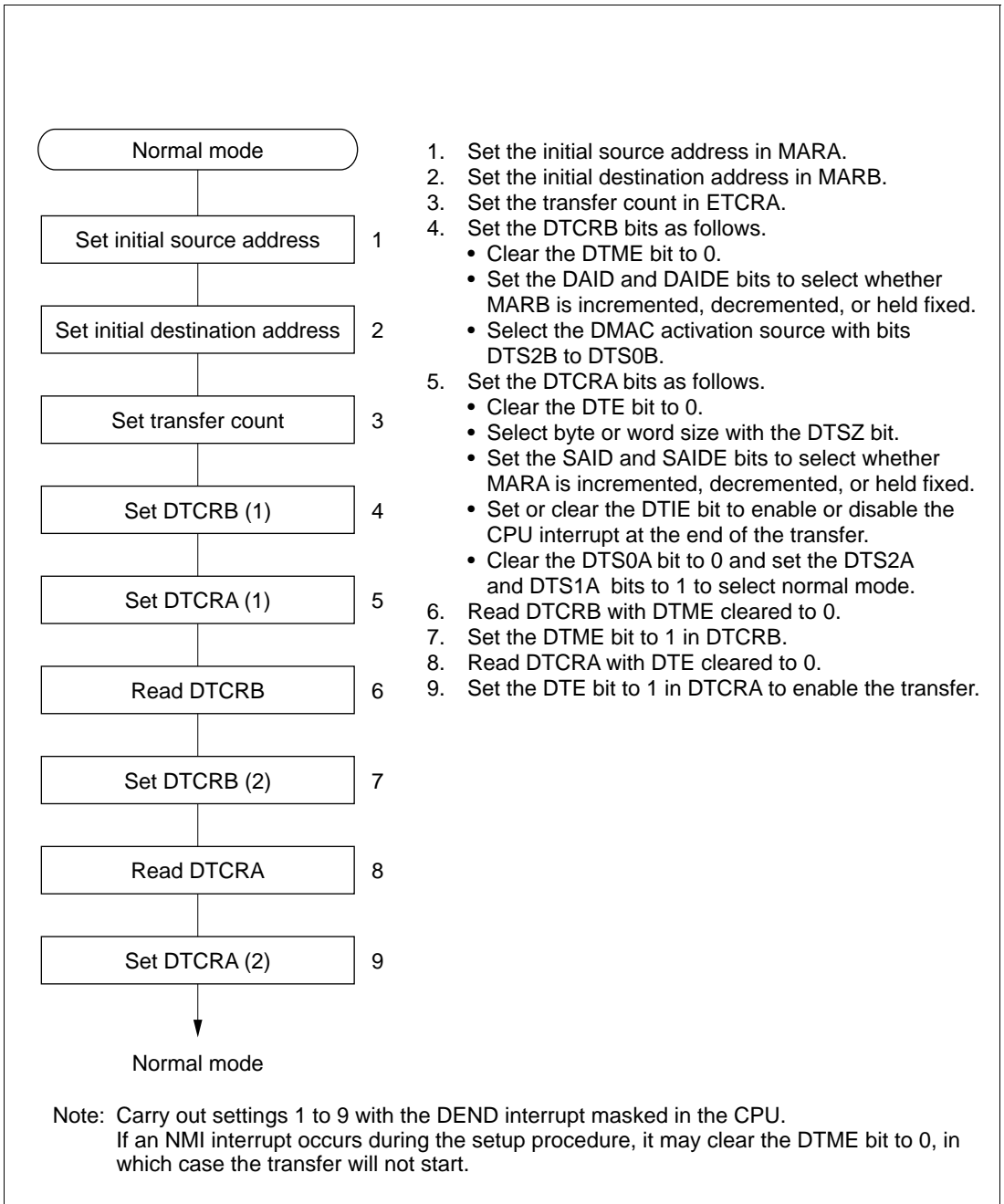


**Figure 7.8 Operation in Normal Mode**

Transfers can be requested (activated) by an external request or auto-request. An auto-requested transfer is activated by the register settings alone. The designated number of transfers are executed automatically. Either cycle-steal or burst mode can be selected. In cycle-steal mode the DMAC releases the bus temporarily after each transfer. In burst mode the DMAC keeps the bus until the transfers are completed, unless there is a bus request from a higher-priority bus master.

For the detailed settings see section 7.3.4, Data Transfer Control Registers (DTCR).

Figure 7.9 shows a sample setup procedure for normal mode.





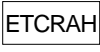

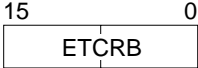
**Figure 7.9 Normal Mode Setup Procedure (Example)**

## 7.4.6 Block Transfer Mode

In block transfer mode the A and B channels are combined. One block of a specified size is transferred per request. A designated number of block transfers are executed. Addresses are specified in MARA and MARB. The block area address can be either held fixed or cycled.

Table 7.10 indicates the register functions in block transfer mode.

**Table 7.10 Register Functions in Block Transfer Mode**

Register	Function	Initial Setting	Operation
23 <span style="float: right;">0</span> 	Source address register	Source start address	Incremented or decremented once per transfer, or held fixed
23 <span style="float: right;">0</span> 	Destination address register	Destination start address	Incremented or decremented once per transfer, or held fixed
<span style="float: right;">7 0</span> 	Block size counter	Block size	Decrementd once per transfer until H'00 is reached, then reloaded from ETCRL
<span style="float: right;">7 0</span> 	Initial block size	Block size	Held fixed
<span style="float: right;">15 0</span> 	Block transfer counter	Number of block transfers	Decrementd once per block transfer until H'0000 is reached and the transfer ends

### Legend

MARA: Memory address register A

MARB: Memory address register B

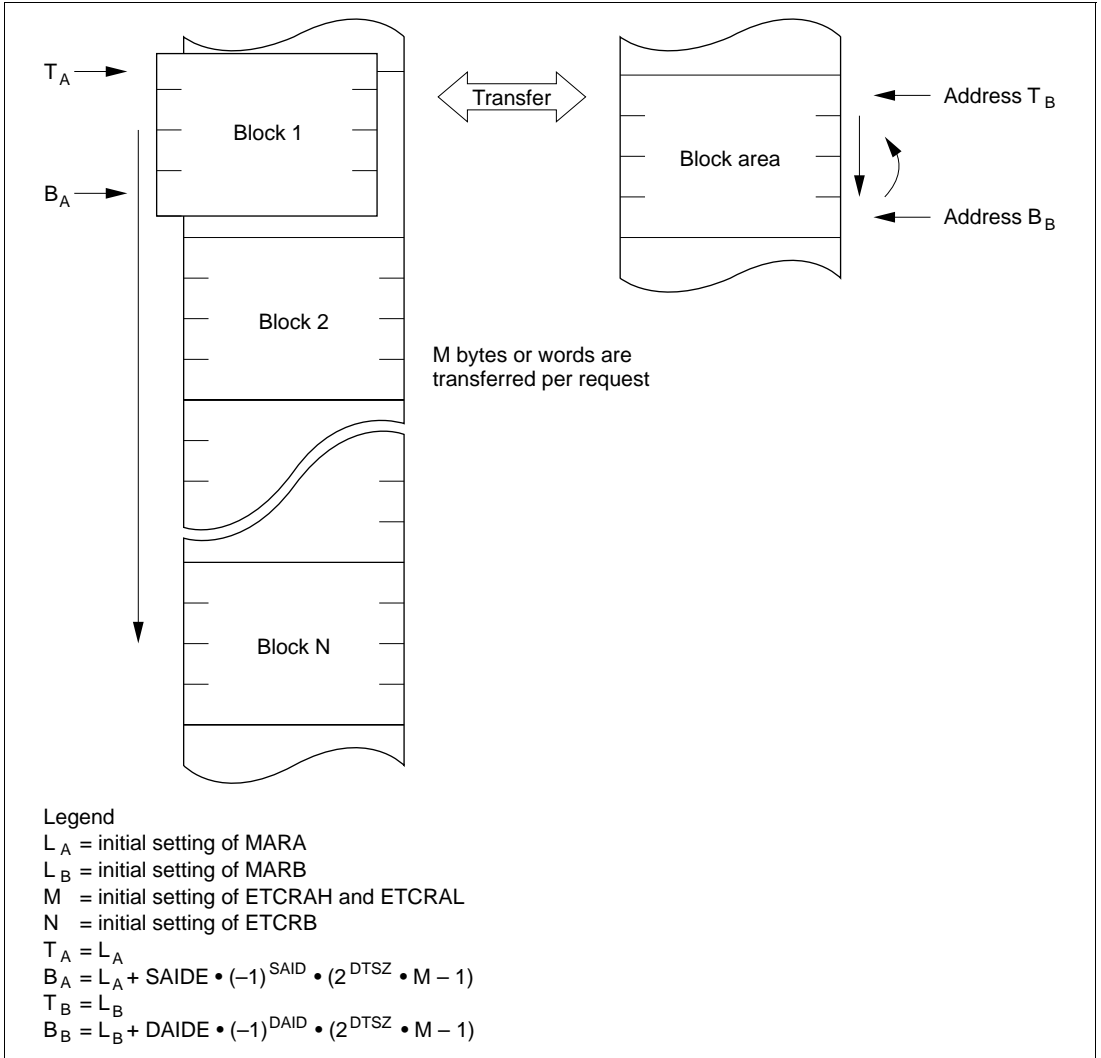
ETCRA: Execute transfer count register A

ETCRB: Execute transfer count register B

The source and destination addresses are both 24-bit addresses. MARA specifies the source address. MARB specifies the destination address. MARA and MARB can be independently incremented, decremented, or held fixed as data is transferred. One of these registers operates as a block area register: even if it is incremented or decremented, it is restored to its initial value at the end of each block transfer. The TMS bit in DTCRB selects whether the block area is the source or destination.

If  $M$  (1 to 255) is the size of the block transferred at each request and  $N$  (1 to 65,536) is the number of blocks to be transferred, then ETCRAH and ETCRAL should initially be set to  $M$  and ETCRB should initially be set to  $N$ .

Figure 7.10 illustrates how block transfer mode operates. In this figure, bit TMS is cleared to 0, meaning the block area is the destination.



**Figure 7.10 Operation in Block Transfer Mode**

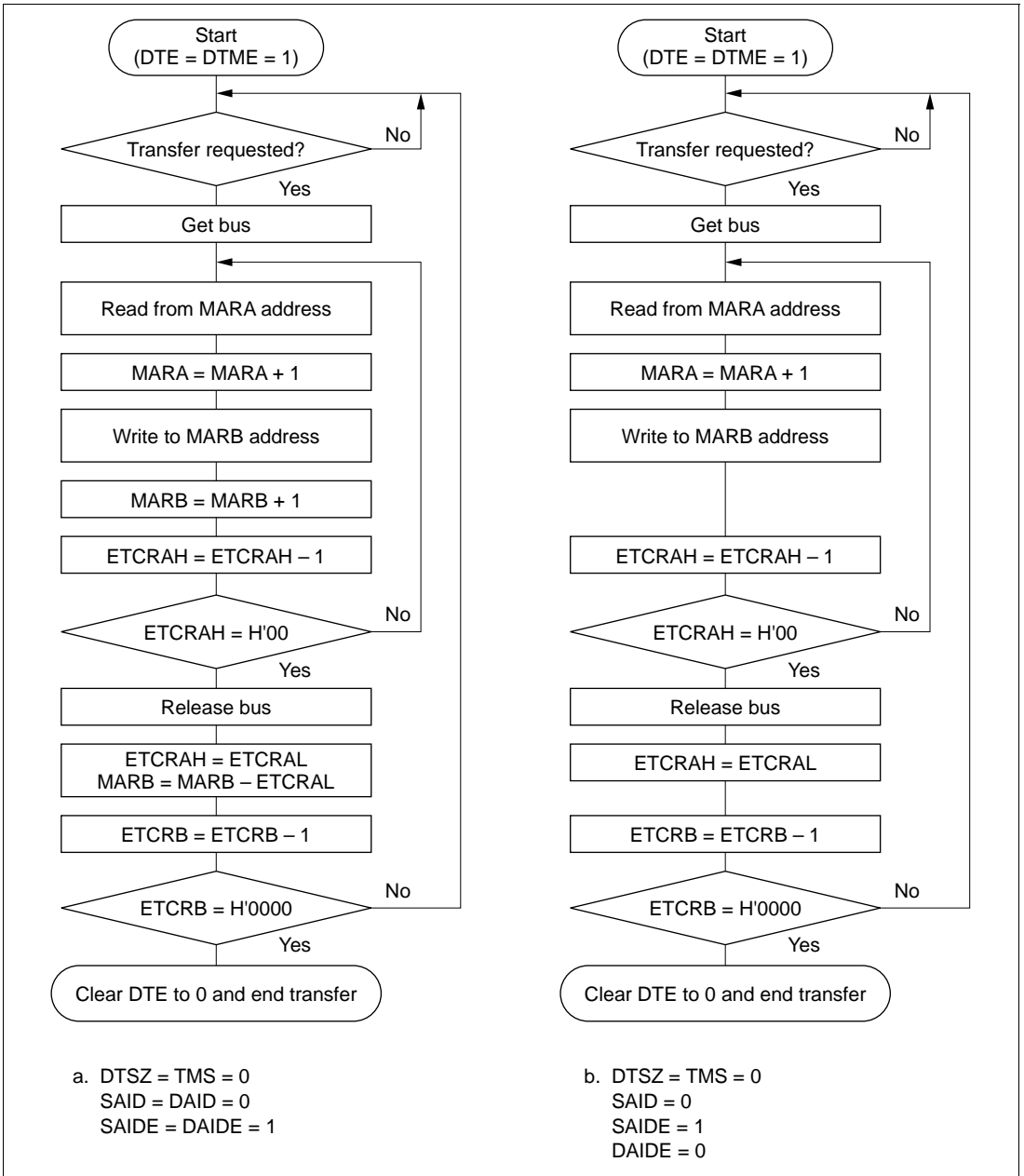
When activated by a transfer request, the DMAC executes a burst transfer. During the transfer MARA and MARB are updated according to the DTCR settings, and ETCRAH is decremented. When ETCRAH reaches H'00, it is reloaded from ETCRAL to restore the initial value. The memory address register of the block area is also restored to its initial value, and ETCRB is decremented. If ETCRB is not H'0000, the DMAC then waits for the next transfer request. ETCRAH and ETCRAL should be initially set to the same value.

The above operation is repeated until ETCRB reaches H'0000, at which point the DTE bit is cleared to 0 and the transfer ends. If the DTIE bit is set to 1, a CPU interrupt is requested at this time.

Figure 7.11 shows examples of a block transfer with byte data size when the block area is the destination. In (a) the block area address is cycled. In (b) the block area address is held fixed.

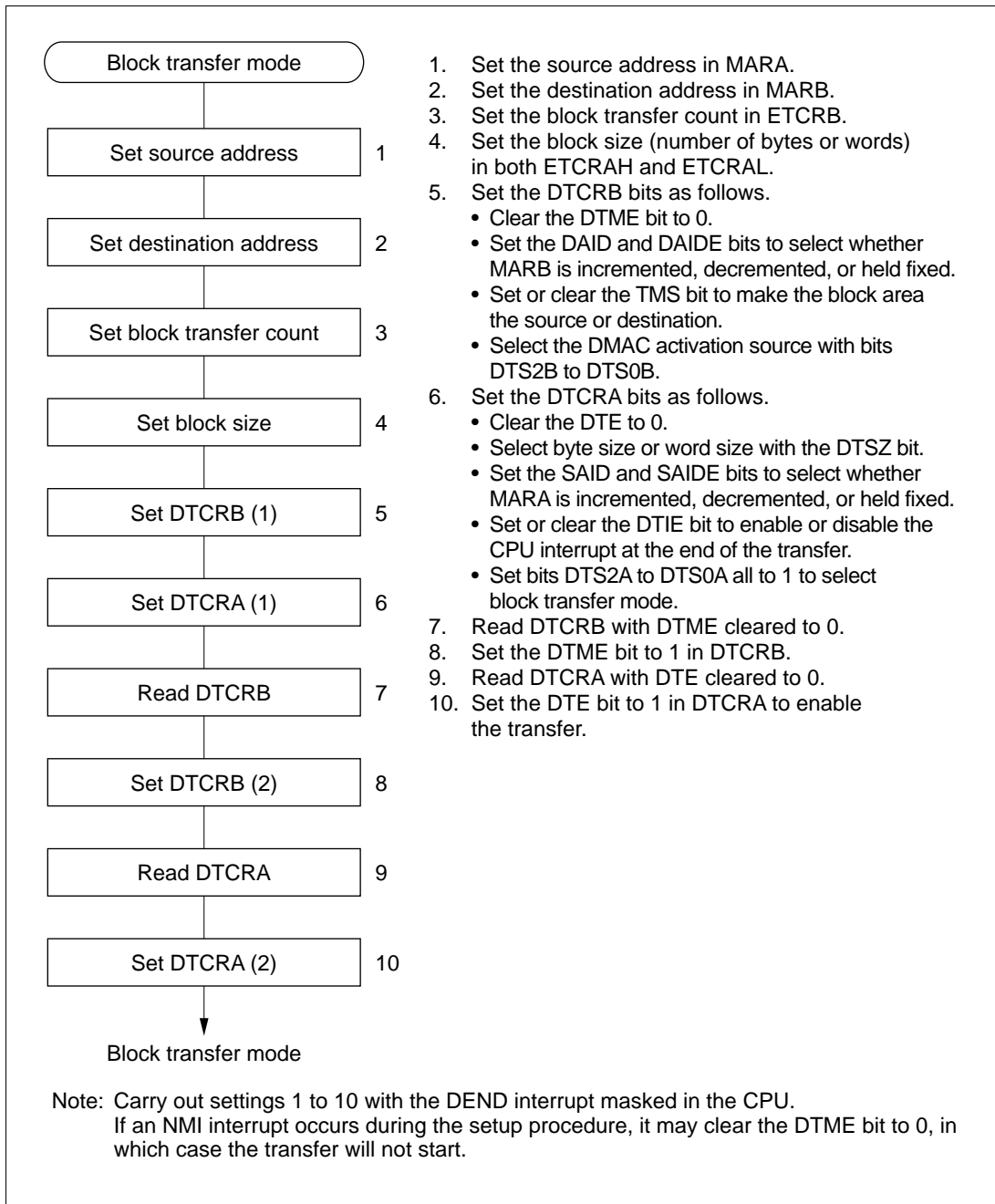
Transfers can be requested (activated) by compare match/input capture A interrupts from ITU channels 0 to 2, by an A/D converter conversion-end interrupt, and by external request signals.

For the detailed settings see section 7.3.4, Data Transfer Control Registers (DTCR).



**Figure 7.11 Block Transfer Mode Flowcharts (Examples)**

Figure 7.12 shows a sample setup procedure for block transfer mode.



**Figure 7.12 Block Transfer Mode Setup Procedure (Example)**



## 7.4.7 DMAC Activation

The DMAC can be activated by an internal interrupt, external request, or auto-request. The available activation sources differ depending on the transfer mode and channel as indicated in table 7.11.

**Table 7.11 DMAC Activation Sources**

Activation Source		Short Address Mode		Full Address Mode	
		Channels	Channels	Normal	Block
		0A and 1A	0B and 1B		
Internal interrupts	IMIA0	○	○	×	○
	IMIA1	○	○	×	○
	IMIA2	○	○	×	○
	ADI	○	○	×	○
	TXI0	○	○	×	×
	RXI0	○	○	×	×
External requests	Falling edge of $\overline{\text{DREQ}}$	×	○	○	○
	Low input at DREQ	×	○	○	×
Auto-request		×	×	○	×

**Activation by Internal Interrupts:** When an interrupt request is selected as a DMAC activation source and the DTE bit is set to 1, that interrupt request is not sent to the CPU. It is not possible for an interrupt request to activate the DMAC and simultaneously generate a CPU interrupt.

When the DMAC is activated by an interrupt request, the interrupt request flag is cleared automatically. If the same interrupt is selected to activate two or more channels, the interrupt request flag is cleared when the highest-priority channel is activated, but the transfer request is held pending on the other channels in the DMAC, which are activated in their priority order.

**Activation by External Request:** If an external request ( $\overline{\text{DREQ}}$  pin) is selected as an activation source, the  $\overline{\text{DREQ}}$  pin becomes an input pin and the corresponding  $\overline{\text{TEND}}$  pin becomes an output pin, regardless of the port data direction register (DDR) settings. The  $\overline{\text{DREQ}}$  input can be level-sensitive or edge-sensitive.

In short address mode and normal mode, an external request operates as follows. If edge sensing is selected, one byte or word is transferred each time a high-to-low transition of the  $\overline{\text{DREQ}}$  input is detected. If the next edge is input before the transfer is completed, the next transfer may not be executed. If level sensing is selected, the transfer continues while  $\overline{\text{DREQ}}$  is low, until the transfer is completed. The bus is released temporarily after each byte or word has been transferred, however. If the  $\overline{\text{DREQ}}$  input goes high during a transfer, the transfer is suspended after the current byte or word has been transferred. When  $\overline{\text{DREQ}}$  goes low, the request is held internally until one byte or word has been transferred. The  $\overline{\text{TEND}}$  signal goes low during the last write cycle.

In block transfer mode, an external request operates as follows. Only edge-sensitive transfer requests are possible in block transfer mode. Each time a high-to-low transition of the  $\overline{\text{DREQ}}$  input is detected, a block of the specified size is transferred. The  $\overline{\text{TEND}}$  signal goes low during the last write cycle in each block.

**Activation by Auto-Request:** The transfer starts as soon as enabled by register setup, and continues until completed. Cycle-steal mode or burst mode can be selected.

In cycle-steal mode the DMAC releases the bus temporarily after transferring each byte or word. Normally, DMAC cycles alternate with CPU cycles.

In burst mode the DMAC keeps the bus until the transfer is completed, unless there is a higher-priority bus request. If there is a higher-priority bus request, the bus is released after the current byte or word has been transferred.

## 7.4.8 DMAC Bus Cycle

Figure 7.13 shows an example of the timing of the basic DMAC bus cycle. This example shows a word-size transfer from a 16-bit two-state access area to an 8-bit three-state access area. When the DMAC gets the bus from the CPU, after one dead cycle ( $T_d$ ), it reads from the source address and writes to the destination address. During these read and write operations the bus is not released even if there is another bus request. DMAC cycles comply with bus controller settings in the same way as CPU cycles.

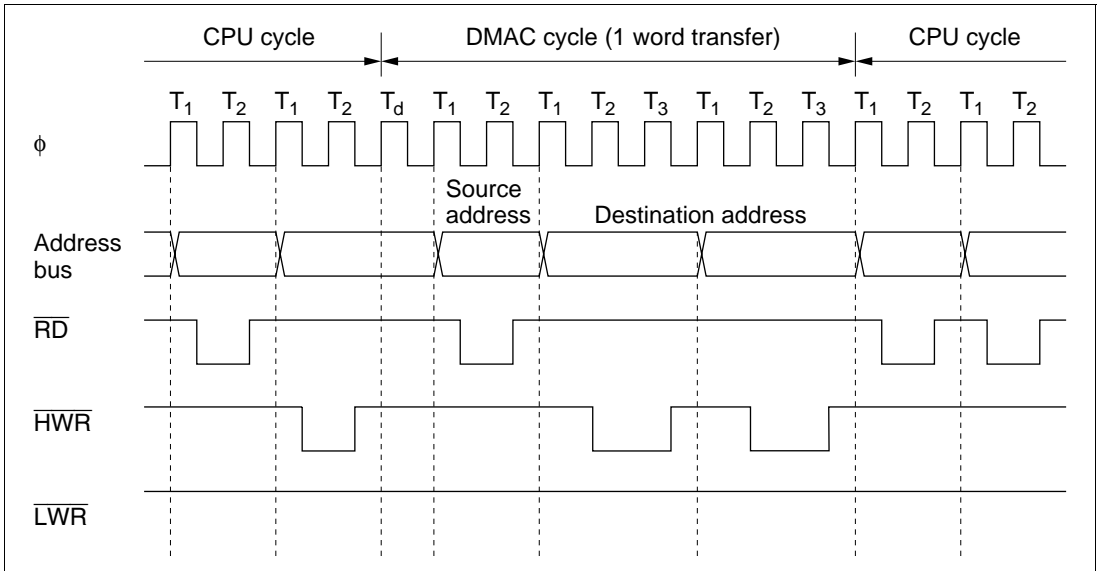
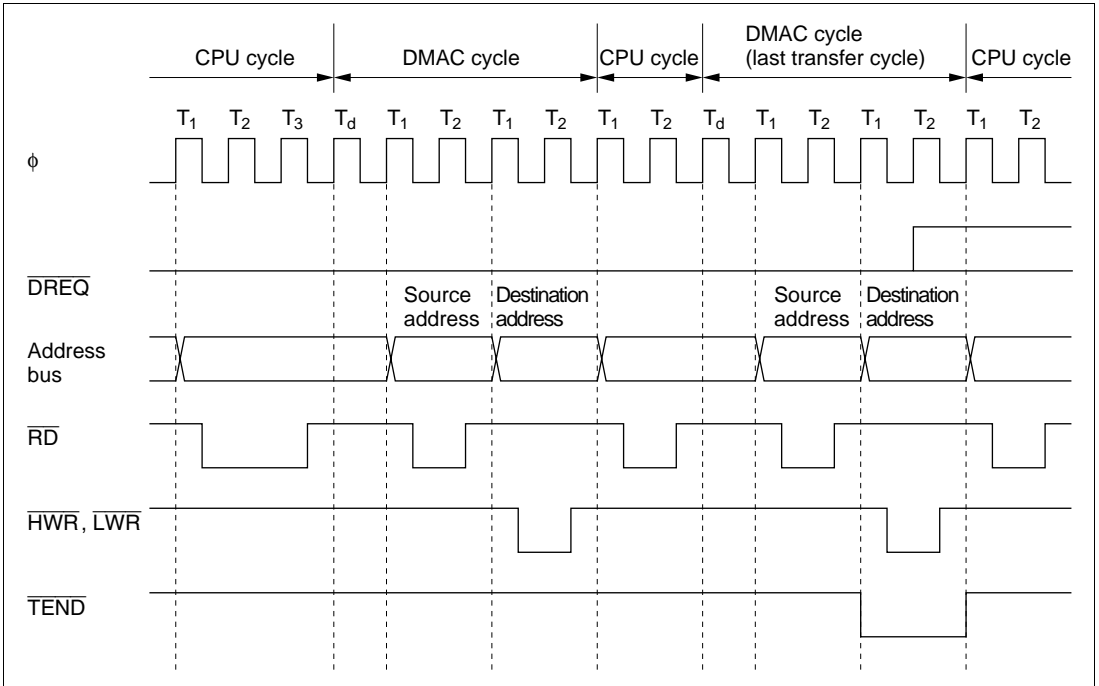


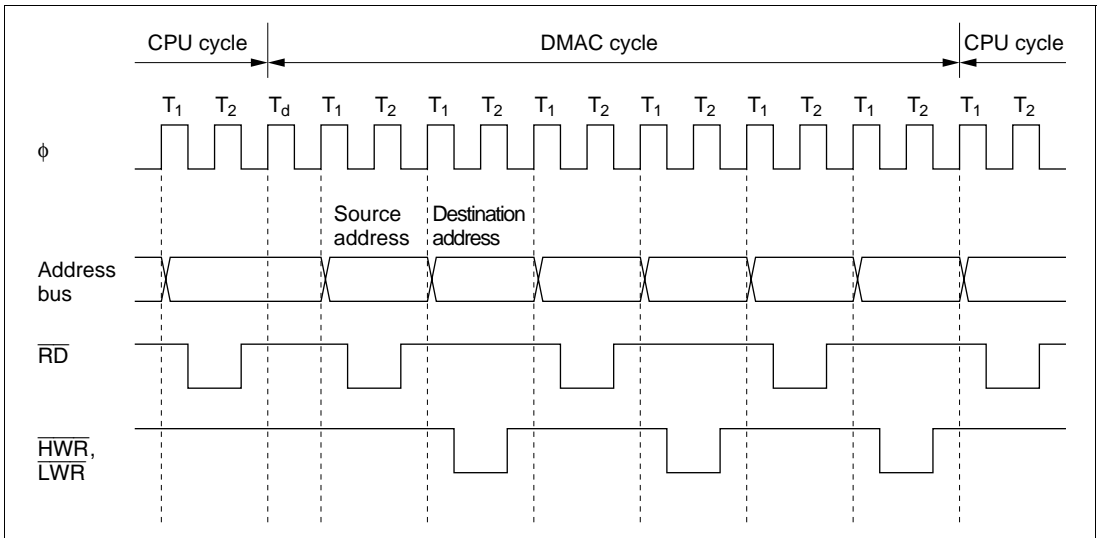
Figure 7.13 DMA Transfer Bus Timing (Example)

Figure 7.14 shows the timing when the DMAC is activated by low input at a  $\overline{\text{DREQ}}$  pin. This example shows a word-size transfer from a 16-bit two-state access area to another 16-bit two-state access area. The DMAC continues the transfer while the  $\overline{\text{DREQ}}$  pin is held low.



**Figure 7.14 Bus Timing of DMA Transfer Requested by Low  $\overline{\text{DREQ}}$  Input**

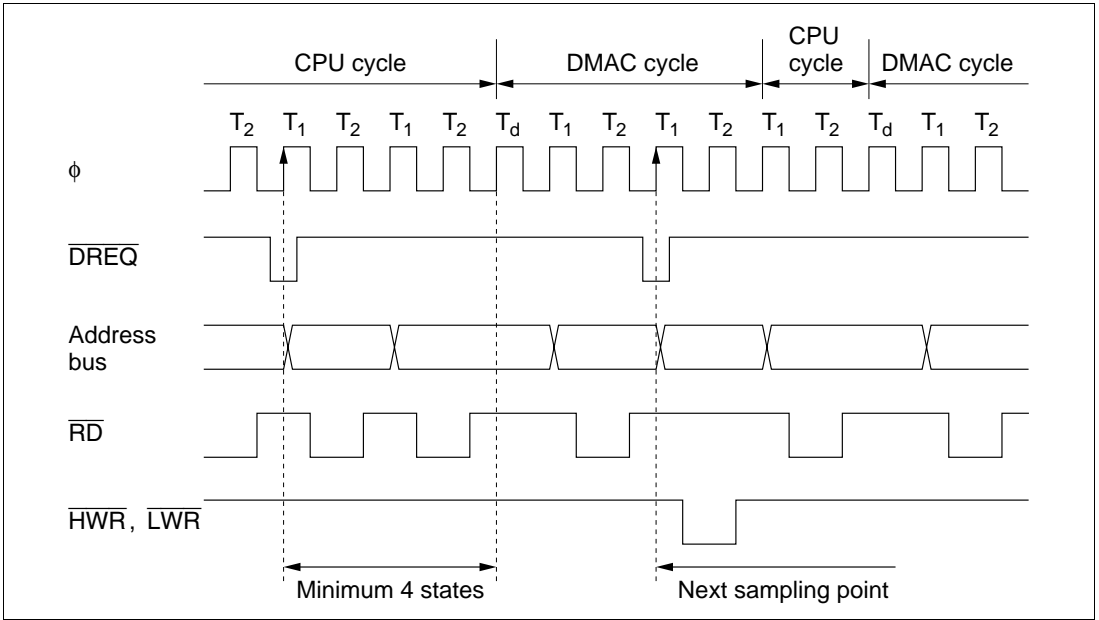
Figure 7.15 shows an auto-requested burst-mode transfer. This example shows a transfer of three words from a 16-bit two-state access area to another 16-bit two-state access area.



**Figure 7.15 Burst DMA Bus Timing**

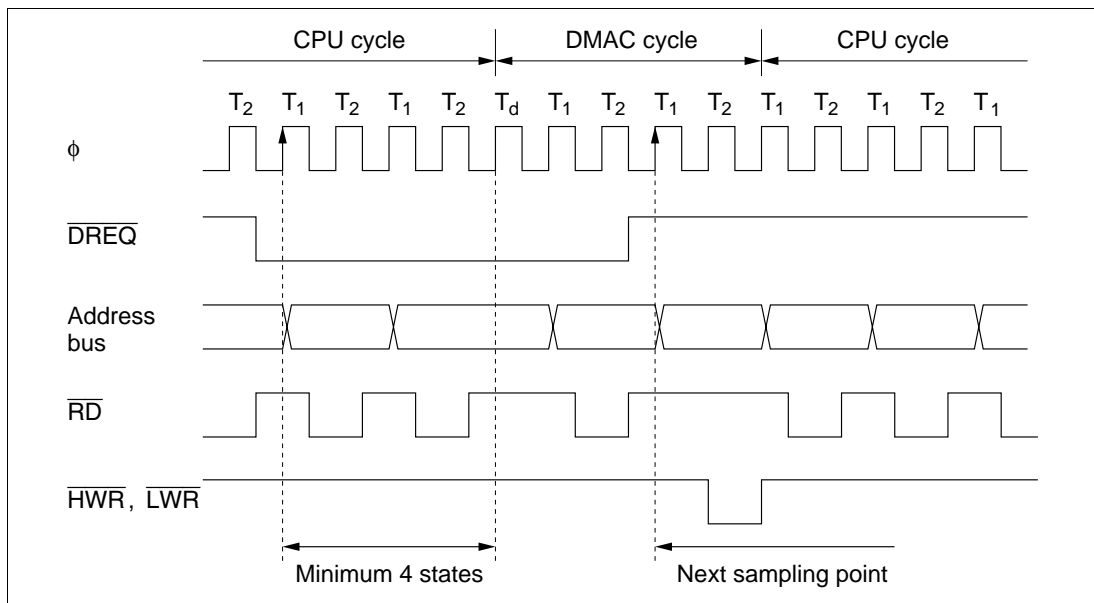
When the DMAC is activated from a  $\overline{DREQ}$  pin there is a minimum interval of four states from when the transfer is requested until the DMAC starts operating. The  $\overline{DREQ}$  pin is not sampled during the time between the transfer request and the start of the transfer. In short address mode and normal mode, the pin is next sampled at the end of the read cycle. In block transfer mode, the pin is next sampled at the end of one block transfer.

Figure 7.16 shows the timing when the DMAC is activated by the falling edge of  $\overline{\text{DREQ}}$  in normal mode.



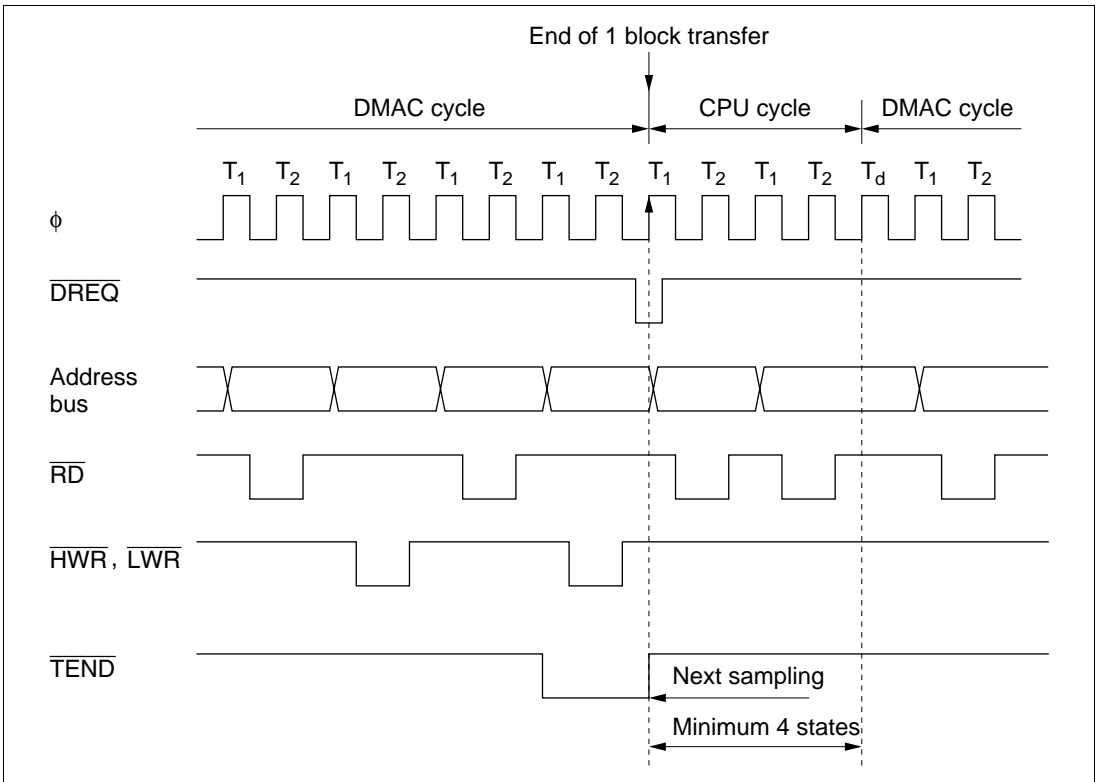
**Figure 7.16** Timing of DMAC Activation by Falling Edge of  $\overline{\text{DREQ}}$  in Normal Mode

Figure 7.17 shows the timing when the DMAC is activated by level-sensitive low  $\overline{\text{DREQ}}$  input in normal mode.



**Figure 7.17 Timing of DMAC Activation by Low  $\overline{\text{DREQ}}$  Level in Normal Mode**

Figure 7.18 shows the timing when the DMAC is activated by the falling edge of  $\overline{\text{DREQ}}$  in block transfer mode.



**Figure 7.18 Timing of DMAC Activation by Falling Edge of  $\overline{\text{DREQ}}$  in Block Transfer Mode**



## 7.4.9 Multiple-Channel Operation

The DMAC channel priority order is: channel 0 > channel 1 and channel A > channel B.

Table 7.12 shows the complete priority order.

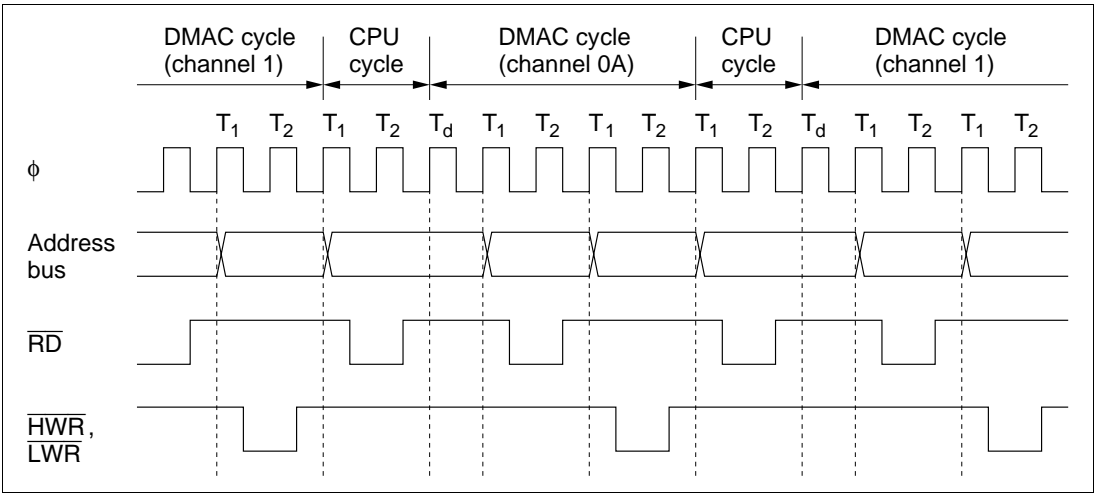
**Table 7.12 Channel Priority Order**

Short Address Mode	Full Address Mode	Priority
Channel 0A	Channel 0	High
Channel 0B		
Channel 1A	Channel 1	Low
Channel 1B		

If transfers are requested on two or more channels simultaneously, or if a transfer on one channel is requested during a transfer on another channel, the DMAC operates as follows.

- When a transfer is requested, the DMAC requests the bus right. When it gets the bus right, it starts a transfer on the highest-priority channel at that time.
- Once a transfer starts on one channel, requests to other channels are held pending until that channel releases the bus.
- After each transfer in short address mode, and each externally-requested or cycle-steal transfer in normal mode, the DMAC releases the bus and returns to step 1. After releasing the bus, if there is a transfer request for another channel, the DMAC requests the bus again.
- After completion of a burst-mode transfer, or after transfer of one block in block transfer mode, the DMAC releases the bus and returns to step 1. If there is a transfer request for a higher-priority channel or a bus request from a higher-priority bus master, however, the DMAC releases the bus after completing the transfer of the current byte or word. After releasing the bus, if there is a transfer request for another channel, the DMAC requests the bus again.

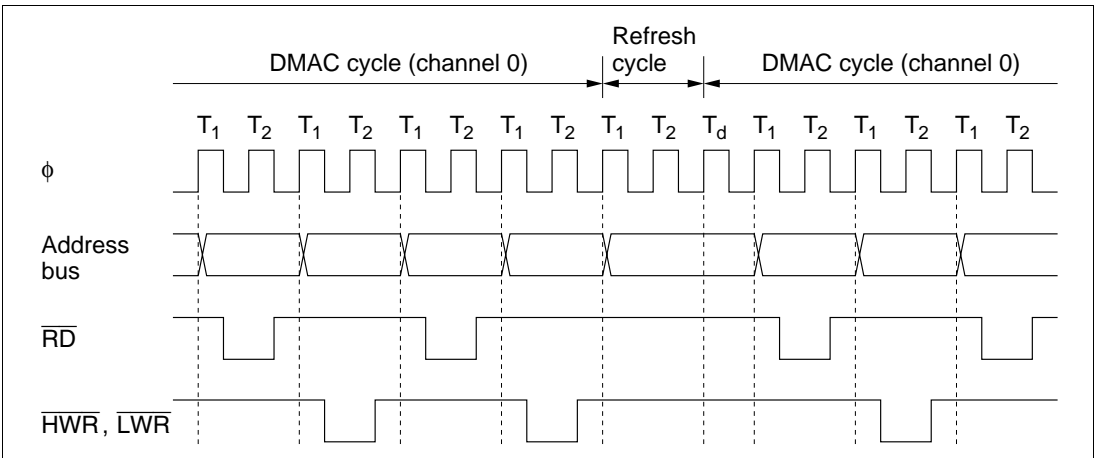
Figure 7.19 shows the timing when channel 0A is set up for I/O mode and channel 1 for burst mode, and a transfer request for channel 0A is received while channel 1 is active.



**Figure 7.19 Timing of Multiple-Channel Operations**

#### 7.4.10 External Bus Requests, DRAM Interface, and DMAC

During a DMAC transfer, if the bus right is requested by an external bus request signal ( $\overline{\text{BREQ}}$ ) or by the DRAM interface (refresh cycle), the DMAC releases the bus after completing the transfer of the current byte or word. If there is a transfer request at this point, the DMAC requests the bus right again. Figure 7.20 shows an example of the timing of insertion of a refresh cycle during a burst transfer on channel 0.



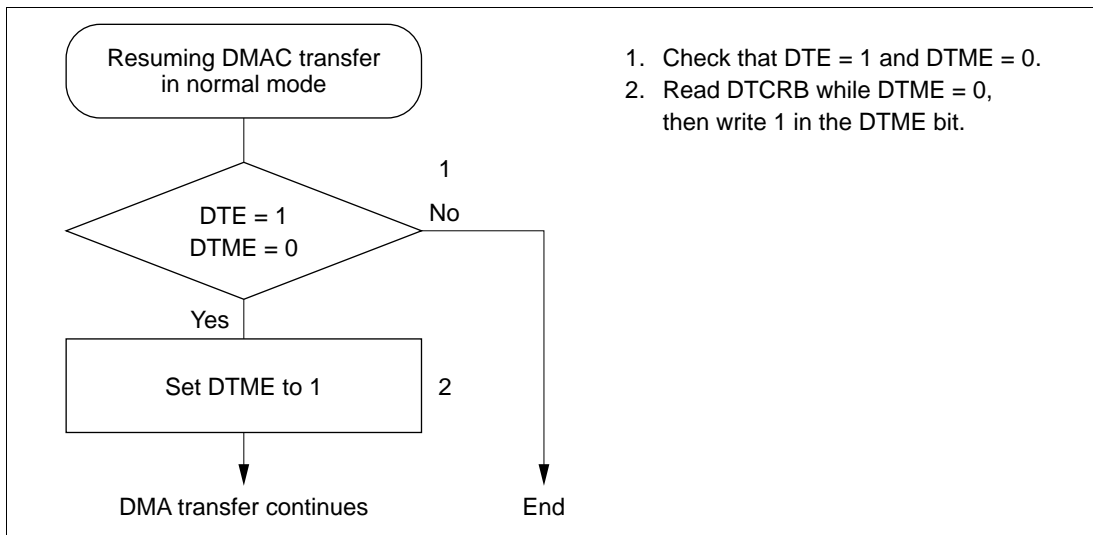
**Figure 7.20 Bus Timing of DRAM Interface, and DMAC**

## 7.4.11 NMI Interrupts and DMAC

NMI interrupts do not affect DMAC operations in short address mode.

If an NMI interrupt occurs during a transfer in full address mode, the DMAC suspends operations. In full address mode, a channel is enabled when its DTE and DTME bits are both set to 1. NMI input clears the DTME bit to 0. After transferring the current byte or word, the DMAC releases the bus to the CPU. In normal mode, the suspended transfer resumes when the CPU sets the DTME bit to 1 again. Check that the DTE bit is set to 1 and the DTME bit is cleared to 0 before setting the DTME bit to 1.

Figure 7.21 shows the procedure for resuming a DMAC transfer in normal mode on channel 0 after the transfer was halted by NMI input.

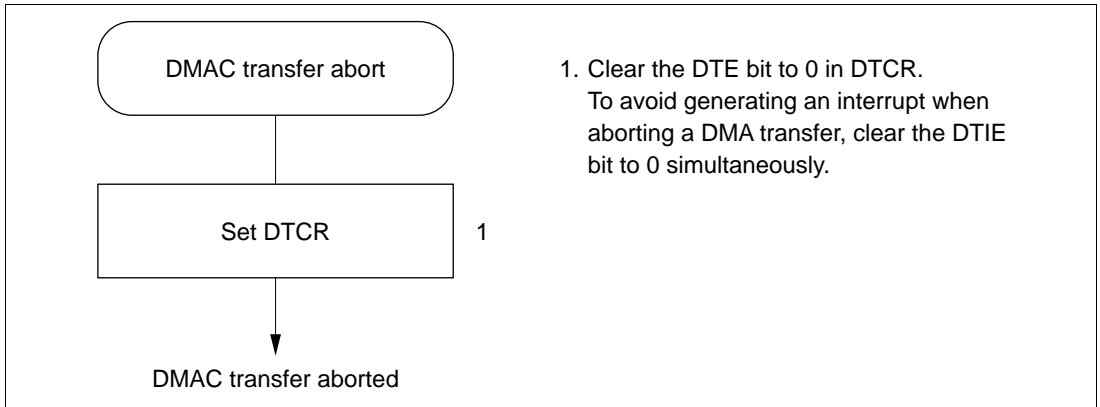


**Figure 7.21 Procedure for Resuming a DMAC Transfer Halted by NMI (Example)**

For information about NMI interrupts in block transfer mode, see section 7.6.6, NMI Interrupts and Block Transfer Mode.

### 7.4.12 Aborting a DMAC Transfer

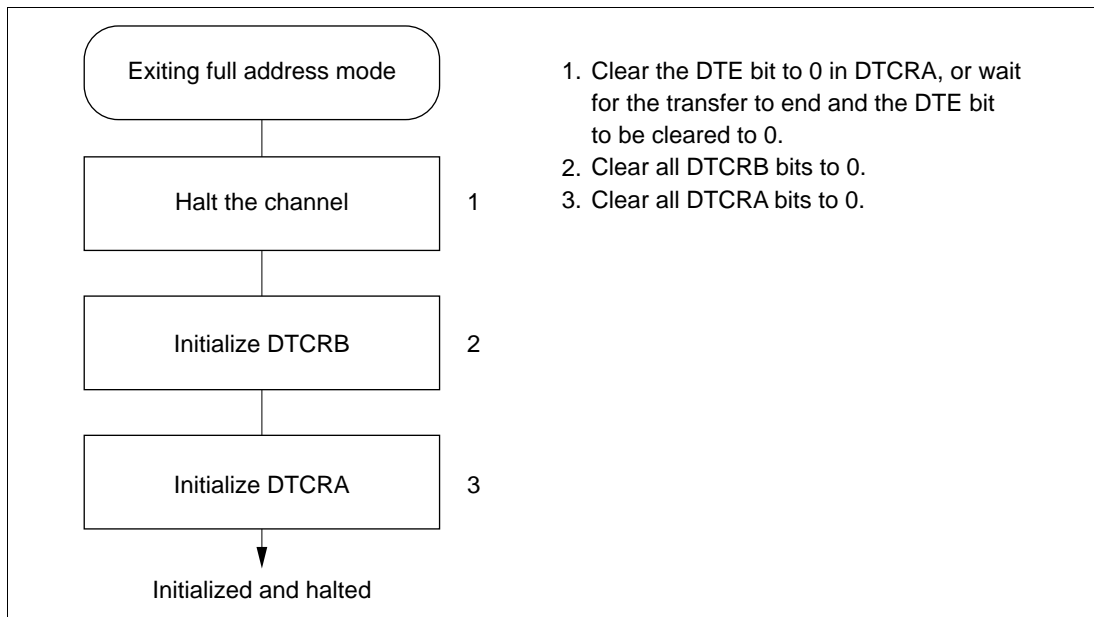
When the DTE bit in an active channel is cleared to 0, the DMAC halts after transferring the current byte or word. The DMAC starts again when the DTE bit is set to 1. In full address mode, the DTME bit can be used for the same purpose. Figure 7.22 shows the procedure for aborting a DMAC transfer by software.



**Figure 7.22 Procedure for Aborting a DMAC Transfer**

### 7.4.13 Exiting Full Address Mode

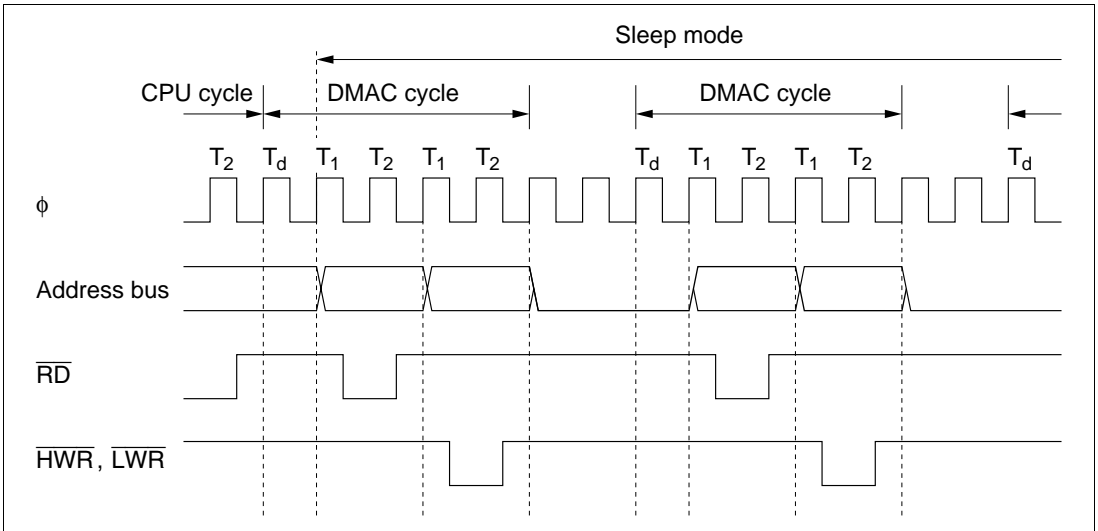
Figure 7.23 shows the procedure for exiting full address mode and initializing the pair of channels. To set the channels up in another mode after exiting full address mode, follow the setup procedure for the relevant mode.



**Figure 7.23 Procedure for Exiting Full Address Mode (Example)**

#### 7.4.14 DMAC States in Reset State, Standby Modes, and Sleep Mode

When the chip is reset or enters software standby mode, the DMAC is initialized and halts. DMAC operations continue in sleep mode. Figure 7.24 shows the timing of a cycle-steal transfer in sleep mode.



**Figure 7.24 Timing of Cycle-Steal Transfer in Sleep Mode**

## 7.5 Interrupts

The DMAC generates only DMA-end interrupts. Table 7.13 lists the interrupts and their priority.

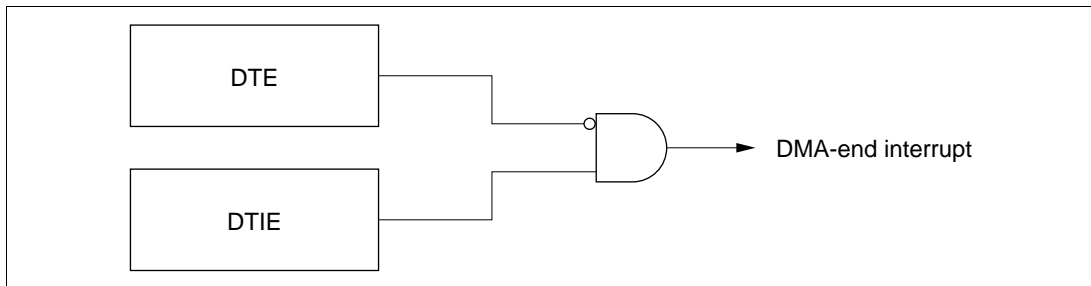
**Table 7.13 DMAC Interrupts**

Interrupt	Description		Interrupt Priority
	Short Address Mode	Full Address Mode	
DEND0A	End of transfer on channel 0A	End of transfer on channel 0	High
DEND0B	End of transfer on channel 0B	—	↑
DEND1A	End of transfer on channel 1A	End of transfer on channel 1	
DEND1B	End of transfer on channel 1B	—	Low

Each interrupt is enabled or disabled by the DTIE bit in the corresponding data transfer control register (DTCR). Separate interrupt signals are sent to the interrupt controller.

The interrupt priority order among channels is channel 0 > channel 1 and channel A > channel B.

Figure 7.25 shows the DMA-end interrupt logic. An interrupt is requested whenever DTE = 0 and DTIE = 1.



**Figure 7.25 DMA-End Interrupt Logic**

The DMA-end interrupt for the B channels (DENDB) is unavailable in full address mode. The DTME bit does not affect interrupt operations.

## 7.6 Usage Notes

### 7.6.1 Note on Word Data Transfer

Word data cannot be accessed starting at an odd address. When word-size transfer is selected, set even values in the memory and I/O address registers (MAR and IOAR).

### 7.6.2 DMAC Self-Access

The DMAC itself cannot be accessed during a DMAC cycle. DMAC registers cannot be specified as source or destination addresses.

### 7.6.3 Longword Access to Memory Address Registers

A memory address register can be accessed as longword data at the MARR address.

Example

```
MOV.L #LBL, ERO
MOV.L ERO, @MARR
```

Four byte accesses are performed. Note that the CPU may release the bus between the second byte (MARE) and third byte (MARH).

Memory address registers should be written and read only when the DMAC is halted.

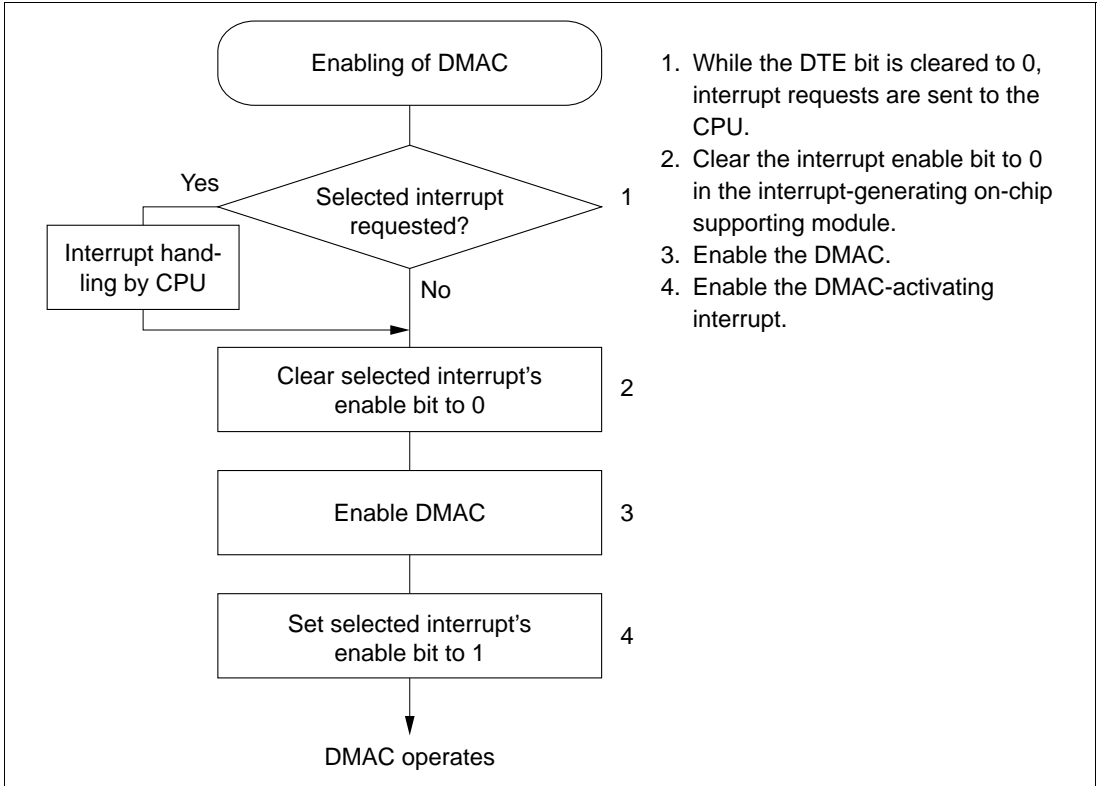
### 7.6.4 Note on Full Address Mode Setup

Full address mode is controlled by two registers: DTCRA and DTCRB. Care must be taken to prevent the B channel from operating in short address mode during the register setup. The enable bits (DTE and DTME) should not be set to 1 until the end of the setup procedure.



## 7.6.5 Note on Activating DMAC by Internal Interrupts

When using an internal interrupt to activate the DMAC, make sure that the interrupt selected as the activating source does not occur during the interval after it has been selected but before the DMAC has been enabled. The on-chip supporting module that will generate the interrupt should not be activated until the DMAC has been enabled. If the DMAC must be enabled while the on-chip supporting module is active, follow the procedure in figure 7.26.



**Figure 7.26 Procedure for Enabling DMAC while On-Chip Supporting Module is Operating (Example)**

If the DTE bit is set to 1 but the DTME bit is cleared to 0, the DMAC is halted and the selected activating source cannot generate a CPU interrupt. If the DMAC is halted by an NMI interrupt, for example, the selected activating source cannot generate CPU interrupts. To terminate DMAC operations in this state, clear the DTE bit to 0 to allow CPU interrupts to be requested. To continue DMAC operations, carry out steps 2 and 4 in figure 7.26 before and after setting the DTME bit to 1.

When 16-bit timer interrupt activates the DMAC, make sure the next interrupt does not occur before the DMA transfer ends. If one 16-bit timer interrupt activates two or more channels, make sure the next interrupt does not occur before the DMA transfers end on all the activated channels. If the next interrupt occurs before a transfer ends, the channel or channels for which that interrupt was selected may fail to accept further activation requests.

### 7.6.6 NMI Interrupts and Block Transfer Mode

If an NMI interrupt occurs in block transfer mode, the DMAC operates as follows.

- When the NMI interrupt occurs, the DMAC finishes transferring the current byte or word, then clears the DTME bit to 0 and halts. The halt may occur in the middle of a block.  
It is possible to find whether a transfer was halted in the middle of a block by checking the block size counter. If the block size counter does not have its initial value, the transfer was halted in the middle of a block.
- If the transfer is halted in the middle of a block, the activating interrupt flag is cleared to 0. The activation request is not held pending.
- While the DTE bit is set to 1 and the DTME bit is cleared to 0, the DMAC is halted and does not accept activating interrupt requests. If an activating interrupt occurs in this state, the DMAC does not operate and does not hold the transfer request pending internally. Neither is a CPU interrupt requested.

For this reason, before setting the DTME bit to 1, first clear the enable bit of the activating interrupt to 0. Then, after setting the DTME bit to 1, set the interrupt enable bit to 1 again. See section 7.6.5, Note on Activating DMAC by Internal Interrupts.

- When the DTME bit is set to 1, the DMAC waits for the next transfer request. If it was halted in the middle of a block transfer, the rest of the block is transferred when the next transfer request occurs. Otherwise, the next block is transferred when the next transfer request occurs.

### 7.6.7 Memory and I/O Address Register Values

Table 7.14 indicates the address ranges that can be specified in the memory and I/O address registers (MAR and IOAR).

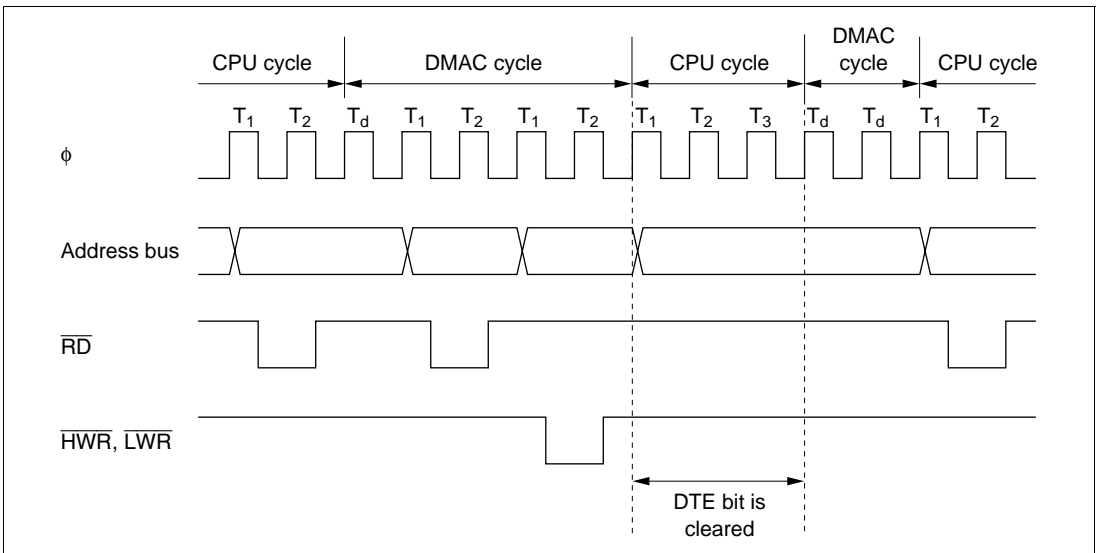
**Table 7.14 Address Ranges Specifiable in MAR and IOAR**

	1-Mbyte Mode	16-Mbyte Mode
MAR	H'00000 to H'FFFFFF (0 to 1048575)	H'000000 to H'FFFFFFF (0 to 16777215)
IOAR	H'FFF00 to H'FFFFFF (1048320 to 1048575)	H'FFFF00 to H'FFFFFFF (16776960 to 16777215)

MAR bits 23 to 20 are ignored in 1-Mbyte mode.

### 7.6.8 Bus Cycle when Transfer is Aborted

When a transfer is aborted by clearing the DTE bit or suspended by an NMI that clears the DTME bit, if this halts a channel for which the DMAC has a transfer request pending internally, a dead cycle may occur. This dead cycle does not update the halted channel's address register or counter value. Figure 7.27 shows an example in which an auto-requested transfer in cycle-steal mode on channel 0 is aborted by clearing the DTE bit in channel 0.



**Figure 7.27 Bus Timing at Abort of DMA Transfer in Cycle-Steal Mode**

### 7.6.9 Transfer Requests by A/D Converter

When the A/D converter is set to scan mode and conversion is performed on more than one channel, the A/D converter generates a transfer request when all conversions are completed. The converted data is stored in the appropriate ADDR registers. Block transfer mode and full address mode should therefore be used to transfer all the conversion results at one time.



# Section 8 I/O Ports

## 8.1 Overview

The H8/3067 Series has 11 input/output ports (ports 1, 2, 3, 4, 5, 6, 7, 8, 9, A, and B). Table 8.1 summarizes the port functions. The pins in each port are multiplexed as shown in table 8.1.

Each port has a data direction register (DDR) for selecting input or output, and a data register (DR) for storing output data. In addition to these registers, ports 2, 4, and 5 have an input pull-up control register (PCR) for switching input pull-up transistors on and off.

Ports 1 to 6 and port 8 can drive one TTL load and a 90-pF capacitive load. Ports 9, A, and B can drive one TTL load and a 30-pF capacitive load. Ports 1 to 6 and 8 to B can drive a darlington pair. Ports 1, 2, and 5 can drive LEDs (with 10-mA current sink). Pins P8<sub>2</sub> to P8<sub>0</sub>, PA<sub>7</sub> to PA<sub>0</sub> have Schmitt-trigger input circuits.

For block diagrams of the ports see appendix C, I/O Port Block Diagrams.

**Table 8.1 Port Functions (1)**

Port	Description	Pins	Expanded Modes					Single-Chip Modes		
			Mode 1	Mode 2	Mode 3	Mode 4	Mode 5	Mode 6	Mode 7	
Port 1	<ul style="list-style-type: none"> <li>8-bit I/O port</li> <li>Can drive LEDs</li> </ul>	P1 <sub>7</sub> to P1 <sub>0</sub> / A <sub>7</sub> to A <sub>0</sub>	Address output pins (A <sub>7</sub> to A <sub>0</sub> )			Address output (A <sub>7</sub> to A <sub>0</sub> ) and generic input DDR = 0: generic input DDR = 1: address output		Generic input/output		
Port 2	<ul style="list-style-type: none"> <li>8-bit I/O port</li> <li>Built-in input pull-up transistors</li> <li>Can drive LEDs</li> </ul>	P2 <sub>7</sub> to P2 <sub>0</sub> / A <sub>15</sub> to A <sub>8</sub>	Address output pins (A <sub>15</sub> to A <sub>8</sub> )			Address output (A <sub>15</sub> to A <sub>8</sub> ) and generic input DDR = 0: generic input DDR = 1: address output		Generic input/output		
Port 3	<ul style="list-style-type: none"> <li>8-bit I/O port</li> </ul>	P3 <sub>7</sub> to P3 <sub>0</sub> / D <sub>15</sub> to D <sub>8</sub>	Data input/output (D <sub>15</sub> to D <sub>8</sub> )					Generic input/output		
Port 4	<ul style="list-style-type: none"> <li>8-bit I/O port</li> <li>Built-in input pull-up transistors</li> </ul>	P4 <sub>7</sub> to P4 <sub>0</sub> / D <sub>7</sub> to D <sub>0</sub>	Data input/output (D <sub>7</sub> to D <sub>0</sub> ) and 8-bit generic input/output 8-bit bus mode: generic input/output 16-bit bus mode: data input/output					Generic input/output		
Port 5	<ul style="list-style-type: none"> <li>4-bit I/O port</li> <li>Built-in input pull-up transistors</li> <li>Can drive LEDs</li> </ul>	P5 <sub>3</sub> to P5 <sub>0</sub> / A <sub>19</sub> to A <sub>16</sub>	Address output (A <sub>19</sub> to A <sub>16</sub> )			Address output (A <sub>19</sub> to A <sub>16</sub> ) and 4-bit generic input DDR = 0: generic input DDR = 1: address output		Generic input/output		
Port 6	<ul style="list-style-type: none"> <li>8-bit I/O port</li> </ul>	P6 <sub>7</sub> /φ	Clock output (φ) and generic input					Generic input/output		
		P6 <sub>7</sub> /LWR P6 <sub>7</sub> /HWR P6 <sub>7</sub> /RD P6 <sub>7</sub> /AS	Bus control signal output (LWR, HWR, RD, AS)							
		P6 <sub>7</sub> /BACK P6 <sub>7</sub> /BREQ P6 <sub>7</sub> /WAIT	Bus control signal input/output (BACK, BREQ, WAIT) and 3-bit generic input/output							
Port 7	<ul style="list-style-type: none"> <li>8-bit I/O port</li> </ul>	P7 <sub>7</sub> /AN <sub>7</sub> /DA <sub>1</sub> P7 <sub>6</sub> /AN <sub>6</sub> /DA <sub>0</sub>	Analog input (AN <sub>7</sub> , AN <sub>6</sub> ) to A/D converter, analog output (DA <sub>1</sub> , DA <sub>0</sub> ) from D/A converter, and generic input							
		P7 <sub>5</sub> to P7 <sub>0</sub> / AN <sub>5</sub> to AN <sub>0</sub>	Analog input (AN <sub>5</sub> to AN <sub>0</sub> ) to A/D converter, and generic input							
Port 8	<ul style="list-style-type: none"> <li>5-bit I/O port</li> <li>P8<sub>2</sub> to P8<sub>5</sub> have Schmitt inputs</li> </ul>	P8 <sub>7</sub> /CS <sub>0</sub>	DDR = 0: generic input			DDR = 0 (reset value):		Generic input/output		
			DDR = 1 (reset value): CS <sub>0</sub> output			generic input				
						DDR = 1: CS <sub>0</sub> output				
P8 <sub>7</sub> /IRQ <sub>3</sub> / CS <sub>1</sub> /ADTRG	IRQ <sub>3</sub> input, CS <sub>1</sub> output, external trigger input (ADTRG) to A/D converter, and generic input					IRQ <sub>3</sub> input, external trigger input (ADTRG) to A/D converter, and generic input/output				
	DDR = 0 (after reset): generic input			DDR = 1: CS <sub>1</sub> output						
	DDR = 0 (reset value): generic input			DDR = 1: CS <sub>2</sub> and CS <sub>3</sub> output						
P8 <sub>7</sub> /IRQ <sub>2</sub> /CS <sub>2</sub> P8 <sub>7</sub> /IRQ <sub>1</sub> /CS <sub>3</sub>	IRQ <sub>2</sub> and IRQ <sub>1</sub> input, CS <sub>2</sub> and CS <sub>3</sub> output, and generic input*					IRQ <sub>2</sub> and IRQ <sub>1</sub> input and generic input/output				
	DDR = 0 (reset value): generic input			DDR = 1: CS <sub>2</sub> and CS <sub>3</sub> output						
P8 <sub>7</sub> /IRQ <sub>0</sub> /RFSH	IRQ <sub>0</sub> input, RFSH output, and generic input/output					IRQ <sub>0</sub> input and generic input/output				

Note: \* P8<sub>1</sub> can be used as an output port by making a setting in DRCRA.

**Table 8.1 Port Functions (1) (cont)**

Port	Description	Pins	Expanded Modes					Single-Chip Modes	
			Mode 1	Mode 2	Mode 3	Mode 4	Mode 5	Mode 6	Mode 7
Port 9	• 6-bit I/O port	P9 <sub>7</sub> / $\overline{\text{IRQ}}_5$ /SCK <sub>1</sub> P9 <sub>6</sub> / $\overline{\text{IRQ}}_4$ /SCK <sub>0</sub> P9 <sub>5</sub> /RxD <sub>1</sub> P9 <sub>4</sub> /RxD <sub>0</sub> P9 <sub>3</sub> /TxD <sub>1</sub> P9 <sub>2</sub> /TxD <sub>0</sub>	Input and output (SCK <sub>1</sub> , SCK <sub>0</sub> , RxD <sub>1</sub> , RxD <sub>0</sub> , TxD <sub>1</sub> , TxD <sub>0</sub> ) for serial communication interfaces 1 and 0 (SCI1/0), $\overline{\text{IRQ}}_5$ and $\overline{\text{IRQ}}_4$ input, and 6-bit generic input/output						
Port A	• 8-bit I/O port • Schmitt inputs	PA <sub>7</sub> /TP <sub>7</sub> <sub>/</sub> TIOCB <sub>2</sub> /A <sub>20</sub>	Output (TP <sub>7</sub> ) from programmable timing pattern controller (TPC), input or output (TIOCB <sub>2</sub> ) for 16-bit timer and generic input/output	Address output (A <sub>20</sub> )	Address output (A <sub>20</sub> ), TPC output (TP <sub>7</sub> ), input or output (TIOCB <sub>2</sub> ) for 16-bit timer, and generic input/output			TPC output (TP <sub>7</sub> ), 16-bit timer input or output (TIOCB <sub>2</sub> ), and generic input/output	
		PA <sub>6</sub> /TP <sub>6</sub> <sub>/</sub> TIOCA <sub>2</sub> /A <sub>21</sub> PA <sub>5</sub> /TP <sub>5</sub> <sub>/</sub> TIOCB <sub>1</sub> /A <sub>22</sub> PA <sub>4</sub> /TP <sub>4</sub> <sub>/</sub> TIOCA <sub>1</sub> /A <sub>23</sub>	TPC output (TP <sub>6</sub> to TP <sub>4</sub> ), 16-bit timer input and output (TIOCA <sub>2</sub> , TIOCB <sub>1</sub> , TIOCA <sub>1</sub> ), and generic input/output	TPC output (TP <sub>6</sub> to TP <sub>4</sub> ), 16-bit timer input and output (TIOCA <sub>2</sub> , TIOCB <sub>1</sub> , TIOCA <sub>1</sub> ), address output (A <sub>23</sub> to A <sub>21</sub> ), and generic input/output			TPC output (TP <sub>6</sub> to TP <sub>4</sub> ), 16-bit timer input and output (TIOCA <sub>2</sub> , TIOCB <sub>1</sub> , TIOCA <sub>1</sub> ) and generic input/output		
		PA <sub>3</sub> /TP <sub>3</sub> <sub>/</sub> TIOCB <sub>0</sub> <sub>/</sub> TCLKD PA <sub>2</sub> /TP <sub>2</sub> <sub>/</sub> TIOCA <sub>0</sub> <sub>/</sub> TCLKC PA <sub>1</sub> /TP <sub>1</sub> <sub>/</sub> TCLKB /TEND <sub>1</sub> PA <sub>0</sub> /TP <sub>0</sub> <sub>/</sub> TCLKA /TEND <sub>0</sub>	TPC output (TP <sub>3</sub> to TP <sub>0</sub> ), 16-bit timer input and output (TIOCB <sub>0</sub> , TIOCA <sub>0</sub> , TCLKD, TCLKC, TCLKB, TCLKA), 8-bit timer input (TCLKD, TCLKC, TCLKB, TCLKA), output (TEND <sub>1</sub> , TEND <sub>0</sub> ) from DMA controller (DMAC), and generic input/output						
Port B	• 8-bit I/O port	PB <sub>7</sub> /TP <sub>15</sub> <sub>/</sub> RXD <sub>2</sub> PB <sub>6</sub> /TP <sub>14</sub> <sub>/</sub> TXD <sub>2</sub> PB <sub>5</sub> /TP <sub>13</sub> <sub>/</sub> SCK <sub>2</sub> /LCAS PB <sub>4</sub> /TP <sub>12</sub> <sub>/</sub> UCAS	TPC output (TP <sub>15</sub> to TP <sub>12</sub> ), SCI2 input and output (SCK <sub>2</sub> , RxD <sub>2</sub> , TxD <sub>2</sub> ), DRAM interface output (LCAS, UCAS), and generic input/output					TPC output (TP <sub>15</sub> to TP <sub>12</sub> ), SCI2 input and output (SCK <sub>2</sub> , RxD <sub>2</sub> , TxD <sub>2</sub> ), and generic input/output	
		PB <sub>3</sub> /TP <sub>11</sub> <sub>/</sub> TMIO <sub>3</sub> <sub>/</sub> DREQ <sub>3</sub> /CS <sub>4</sub> PB <sub>2</sub> /TP <sub>10</sub> <sub>/</sub> TMO <sub>2</sub> /CS <sub>5</sub> PB <sub>1</sub> /TP <sub>9</sub> <sub>/</sub> TMIO <sub>1</sub> <sub>/</sub> DREQ <sub>1</sub> /CS <sub>6</sub> PB <sub>0</sub> /TP <sub>8</sub> <sub>/</sub> TMO <sub>0</sub> /CS <sub>7</sub>	TPC output (TP <sub>11</sub> to TP <sub>8</sub> ), 8-bit timer input and output (TMIO <sub>3</sub> , TMO <sub>2</sub> , TMIO <sub>1</sub> , TMO <sub>0</sub> ), DMAC input ( $\overline{\text{DREQ}}_3$ , $\overline{\text{DREQ}}_1$ ), CS <sub>7</sub> to CS <sub>5</sub> output, and generic input/output			TPC output (TP <sub>11</sub> to TP <sub>8</sub> ), 8-bit timer input and output (TMIO <sub>3</sub> , TMO <sub>2</sub> , TMIO <sub>1</sub> , TMO <sub>0</sub> ), DMAC input ( $\overline{\text{DREQ}}_3$ , $\overline{\text{DREQ}}_1$ ), and generic input/output			

## 8.2 Port 1

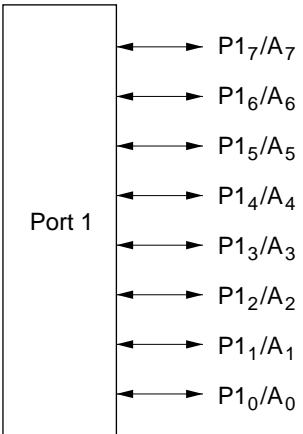
### 8.2.1 Overview

Port 1 is an 8-bit input/output port also used for address output, with the pin configuration shown in figure 8.1. The pin functions differ between the expanded modes with on-chip ROM disabled, expanded modes with on-chip ROM enabled, and single-chip mode. In modes 1 to 4 (expanded modes with on-chip ROM disabled), they are address bus output pins ( $A_7$  to  $A_0$ ).

In modes 5 (expanded modes with on-chip ROM enabled), settings in the port 1 data direction register (P1DDR) can designate pins for address bus output ( $A_7$  to  $A_0$ ) or generic input. In mode 6 and 7 (single-chip mode), port 1 is a generic input/output port.

When DRAM is connected to area 2, 3, 4, 5,  $A_7$  to  $A_0$  output row and column addresses in read and write cycles. For details see section 6.5, DRAM Interface.

Pins in port 1 can drive one TTL load and a 90-pF capacitive load. They can also drive an LED or a darlington transistor pair.

Port 1 pins	Modes 1 to 4	Modes 5	Mode 6 and 7
	$A_7$ (output)	$P1_7$ (input)/ $A_7$ (output)	$P1_7$ (input/output)
	$A_6$ (output)	$P1_6$ (input)/ $A_6$ (output)	$P1_6$ (input/output)
	$A_5$ (output)	$P1_5$ (input)/ $A_5$ (output)	$P1_5$ (input/output)
	$A_4$ (output)	$P1_4$ (input)/ $A_4$ (output)	$P1_4$ (input/output)
	$A_3$ (output)	$P1_3$ (input)/ $A_3$ (output)	$P1_3$ (input/output)
	$A_2$ (output)	$P1_2$ (input)/ $A_2$ (output)	$P1_2$ (input/output)
	$A_1$ (output)	$P1_1$ (input)/ $A_1$ (output)	$P1_1$ (input/output)
	$A_0$ (output)	$P1_0$ (input)/ $A_0$ (output)	$P1_0$ (input/output)

**Figure 8.1 Port 1 Pin Configuration**



## 8.2.2 Register Descriptions

Table 8.2 summarizes the registers of port 1.

**Table 8.2 Port 1 Registers**

Address*	Name	Abbreviation	R/W	Initial Value	
				Modes 1 to 4	Modes 5 to 7
H'EE000	Port 1 data direction register	P1DDR	W	H'FF	H'00
H'FFFD0	Port 1 data register	P1DR	R/W	H'00	H'00

Note: \* Lower 20 bits of the address in advanced mode.

**Port 1 Data Direction Register (P1DDR):** P1DDR is an 8-bit write-only register that can select input or output for each pin in port 1.

Bit		7	6	5	4	3	2	1	0
		P1 <sub>7</sub> DDR	P1 <sub>6</sub> DDR	P1 <sub>5</sub> DDR	P1 <sub>4</sub> DDR	P1 <sub>3</sub> DDR	P1 <sub>2</sub> DDR	P1 <sub>1</sub> DDR	P1 <sub>0</sub> DDR
Modes 1 to 4	Initial value	1	1	1	1	1	1	1	1
	Read/Write	—	—	—	—	—	—	—	—
Modes 5 to 7	Initial value	0	0	0	0	0	0	0	0
	Read/Write	W	W	W	W	W	W	W	W

**Port 1 data direction 7 to 0**

These bits select input or output for port 1 pins

**Modes 1 to 4 (Expanded Modes with On-Chip ROM Disabled):** P1DDR values are fixed at 1. Port 1 functions as an address bus.

**Modes 5 (Expanded Modes with On-Chip ROM Enabled):** After a reset, port 1 functions as an input port. A pin in port 1 becomes an address output pin if the corresponding P1DDR bit is set to 1, and a generic input pin if this bit is cleared to 0.

**Mode 6 and 7 (Single-Chip Mode):** Port 1 functions as an input/output port. A pin in port 1 becomes an output port if the corresponding P1DDR bit is set to 1, and an input port if this bit is cleared to 0.

In modes 1 to 4, P1DDR bits are always read as 1, and cannot be modified.

In modes 5 to 7, P1DDR is a write-only register. Its value cannot be read. All bits return 1 when read.

P1DDR is initialized to H'FF in modes 1 to 4, and to H'00 in modes 5 to 7, by a reset and in hardware standby mode. In software standby mode it retains its previous setting. Therefore, if a transition is made to software standby mode while port 1 is functioning as an input/output port and a P1DDR bit is set to 1, the corresponding pin maintains its output state.

**Port 1 Data Register (P1DR):** P1DR is an 8-bit readable/writable register that stores port 1 output data. When port 1 functions as an output port, the value of this register is output. When this register is read, the pin logic level is read for bits for which the P1DDR setting is 0, and the P1DR value is read for bits for which the P1DDR setting is 1.

Bit	7	6	5	4	3	2	1	0
	P1 <sub>7</sub>	P1 <sub>6</sub>	P1 <sub>5</sub>	P1 <sub>4</sub>	P1 <sub>3</sub>	P1 <sub>2</sub>	P1 <sub>1</sub>	P1 <sub>0</sub>
Initial value	0	0	0	0	0	0	0	0
Read/Write	R/W	R/W	R/W	R/W	R/W	R/W	R/W	R/W

**Port 1 data 7 to 0**

These bits store data for port 1 pins

P1DR is initialized to H'00 by a reset and in hardware standby mode. In software standby mode it retains its previous setting.

## 8.3 Port 2

### 8.3.1 Overview

Port 2 is an 8-bit input/output port with the pin configuration shown in figure 8.2. The pin functions differ according to the operating mode.

In modes 1 to 4 (expanded modes with on-chip ROM disabled), port 2 consists of address bus output pins ( $A_{15}$  to  $A_8$ ). In modes 5 (expanded modes with on-chip ROM enabled), settings in the port 2 data direction register (P2DDR) can designate pins for address bus output ( $A_{15}$  to  $A_8$ ) or generic input. In mode 6 and 7 (single-chip mode), port 2 is a generic input/output port.

When DRAM is connected to areas 2 to 5,  $A_{12}$  to  $A_8$  output row and column addresses in read and write cycles. For details see section 6.5, DRAM Interface.

Port 2 has software-programmable built-in pull-up transistors.

Pins in port 2 can drive one TTL load and a 90-pF capacitive load. They can also drive an LED or a darlington transistor pair.

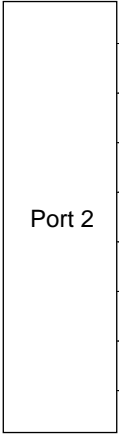
Port 2 pins	Modes 1 to 4	Modes 5	Mode 6 and 7
 P2 <sub>7</sub> /A <sub>15</sub>	A <sub>15</sub> (output)	P2 <sub>7</sub> (input)/A <sub>15</sub> (output)	P2 <sub>7</sub> (input/output)
P2 <sub>6</sub> /A <sub>14</sub>	A <sub>14</sub> (output)	P2 <sub>6</sub> (input)/A <sub>14</sub> (output)	P2 <sub>6</sub> (input/output)
P2 <sub>5</sub> /A <sub>13</sub>	A <sub>13</sub> (output)	P2 <sub>5</sub> (input)/A <sub>13</sub> (output)	P2 <sub>5</sub> (input/output)
P2 <sub>4</sub> /A <sub>12</sub>	A <sub>12</sub> (output)	P2 <sub>4</sub> (input)/A <sub>12</sub> (output)	P2 <sub>4</sub> (input/output)
P2 <sub>3</sub> /A <sub>11</sub>	A <sub>11</sub> (output)	P2 <sub>3</sub> (input)/A <sub>11</sub> (output)	P2 <sub>3</sub> (input/output)
P2 <sub>2</sub> /A <sub>10</sub>	A <sub>10</sub> (output)	P2 <sub>2</sub> (input)/A <sub>10</sub> (output)	P2 <sub>2</sub> (input/output)
P2 <sub>1</sub> /A <sub>9</sub>	A <sub>9</sub> (output)	P2 <sub>1</sub> (input)/A <sub>9</sub> (output)	P2 <sub>1</sub> (input/output)
P2 <sub>0</sub> /A <sub>8</sub>	A <sub>8</sub> (output)	P2 <sub>0</sub> (input)/A <sub>8</sub> (output)	P2 <sub>0</sub> (input/output)

Figure 8.2 Port 2 Pin Configuration

### 8.3.2 Register Descriptions

Table 8.3 summarizes the registers of port 2.

**Table 8.3 Port 2 Registers**

Address*	Name	Abbreviation	R/W	Initial Value	
				Modes 1 to 4	Modes 5 to 7
H'EE001	Port 2 data direction register	P2DDR	W	H'FF	H'00
H'FFFD1	Port 2 data register	P2DR	R/W	H'00	H'00
H'EE03C	Port 2 input pull-up MOS control register	P2PCR	R/W	H'00	H'00

Note: \* Lower 20 bits of the address in advanced mode.

**Port 2 Data Direction Register (P2DDR):** P2DDR is an 8-bit write-only register that can select input or output for each pin in port 2.

Bit		7	6	5	4	3	2	1	0
		P2 <sub>7</sub> DDR	P2 <sub>6</sub> DDR	P2 <sub>5</sub> DDR	P2 <sub>4</sub> DDR	P2 <sub>3</sub> DDR	P2 <sub>2</sub> DDR	P2 <sub>1</sub> DDR	P2 <sub>0</sub> DDR
Modes 1 to 4	Initial value	1	1	1	1	1	1	1	1
	Read/Write	—	—	—	—	—	—	—	—
Modes 5 to 7	Initial value	0	0	0	0	0	0	0	0
	Read/Write	W	W	W	W	W	W	W	W

**Port 2 data direction 7 to 0**

These bits select input or output for port 2 pins

**Modes 1 to 4 (Expanded Modes with On-Chip ROM Disabled):** P2DDR values are fixed at 1. Port 2 functions as an address bus.

**Modes 5 (Expanded Modes with On-Chip ROM Enabled):** Following a reset, port 2 is an input port. A pin in port 2 becomes an address output pin if the corresponding P2DDR bit is set to 1, and a generic input port if this bit is cleared to 0.

**Mode 6 and 7 (Single-Chip Mode):** Port 2 functions as an input/output port. A pin in port 2 becomes an output port if the corresponding P2DDR bit is set to 1, and an input port if this bit is cleared to 0.

In modes 1 to 4, P2DDR bits are always read as 1, and cannot be modified.

In modes 5 to 7, P2DDR is a write-only register. Its value cannot be read. All bits return 1 when read.

P2DDR is initialized to H'FF in modes 1 to 4, and to H'00 in modes 5 to 7, by a reset and in hardware standby mode. In software standby mode it retains its previous setting. Therefore, if a transition is made to software standby mode while port 2 is functioning as an input/output port and a P2DDR bit is set to 1, the corresponding pin maintains its output state.

**Port 2 Data Register (P2DR):** P2DR is an 8-bit readable/writable register that stores output data for Port 2. When port 2 functions as an output port, the value of this register is output. When a bit in P2DDR is set to 1, if port 2 is read the value of the corresponding P2DR bit is returned. When a bit in P2DDR is cleared to 0, if port 2 is read the corresponding pin logic level is read.

Bit	7	6	5	4	3	2	1	0
	P2 <sub>7</sub>	P2 <sub>6</sub>	P2 <sub>5</sub>	P2 <sub>4</sub>	P2 <sub>3</sub>	P2 <sub>2</sub>	P2 <sub>1</sub>	P2 <sub>0</sub>
Initial value	0	0	0	0	0	0	0	0
Read/Write	R/W	R/W	R/W	R/W	R/W	R/W	R/W	R/W

**Port 2 data 7 to 0**

These bits store data for port 2 pins

P2DR is initialized to H'00 by a reset and in hardware standby mode. In software standby mode it retains its previous setting.

**Port 2 Input Pull-Up MOS Control Register (P2PCR):** P2PCR is an 8-bit readable/writable register that controls the MOS input pull-up transistors in port 2.

Bit	7	6	5	4	3	2	1	0
	P2 <sub>7</sub> PCR	P2 <sub>6</sub> PCR	P2 <sub>5</sub> PCR	P2 <sub>4</sub> PCR	P2 <sub>3</sub> PCR	P2 <sub>2</sub> PCR	P2 <sub>1</sub> PCR	P2 <sub>0</sub> PCR
Initial value	0	0	0	0	0	0	0	0
Read/Write	R/W	R/W	R/W	R/W	R/W	R/W	R/W	R/W

**Port 2 input pull-up MOS control 7 to 0**

These bits control input pull-up transistors built into port 2

In modes 5 to 7, when a P2DDR bit is cleared to 0 (selecting generic input), if the corresponding bit in P2PCR is set to 1, the input pull-up transistor is turned on.

P2PCR is initialized to H'00 by a reset and in hardware standby mode. In software standby mode it retains its previous setting.

**Table 8.4 Input Pull-Up Transistor States (Port 2)**

<b>Mode</b>	<b>Reset</b>	<b>Hardware Standby Mode</b>	<b>Software Standby Mode</b>	<b>Other Modes</b>
1	Off	Off	Off	Off
2				
3				
4				
5	Off	Off	On/off	On/off
6				
7				

**Legend**

Off: The input pull-up transistor is always off.

On/off: The input pull-up transistor is on if P2PCR = 1 and P2DDR = 0. Otherwise, it is off.

## 8.4 Port 3

### 8.4.1 Overview

Port 3 is an 8-bit input/output port with the pin configuration shown in figure 8.3. Port 3 is a data bus in modes 1 to 5 (expanded modes) and a generic input/output port in mode 6, 7 (single-chip mode).

Pins in port 3 can drive one TTL load and a 90-pF capacitive load. They can also drive a darlington transistor pair.

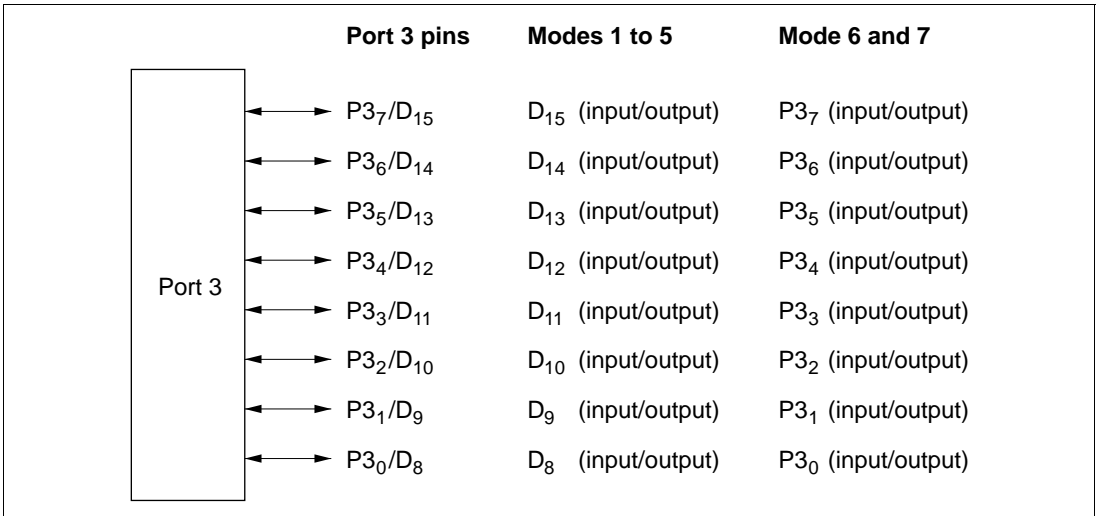


Figure 8.3 Port 3 Pin Configuration

### 8.4.2 Register Descriptions

Table 8.5 summarizes the registers of port 3.

Table 8.5 Port 3 Registers

Address*	Name	Abbreviation	R/W	Initial Value
H'EE002	Port 3 data direction register	P3DDR	W	H'00
H'FFFD2	Port 3 data register	P3DR	R/W	H'00

Note: \* Lower 20 bits of the address in advanced mode.

**Port 3 Data Direction Register (P3DDR):** P3DDR is an 8-bit write-only register that can select input or output for each pin in port 3.

Bit	7	6	5	4	3	2	1	0
	P3 <sub>7</sub> DDR	P3 <sub>6</sub> DDR	P3 <sub>5</sub> DDR	P3 <sub>4</sub> DDR	P3 <sub>3</sub> DDR	P3 <sub>2</sub> DDR	P3 <sub>1</sub> DDR	P3 <sub>0</sub> DDR
Initial value	0	0	0	0	0	0	0	0
Read/Write	W	W	W	W	W	W	W	W

**Port 3 data direction 7 to 0**

These bits select input or output for port 3 pins

**Modes 1 to 5 (Expanded Modes):** Port 3 functions as a data bus, regardless of the P3DDR settings.

**Mode 6 and 7 (Single-Chip Mode):** Port 3 functions as an input/output port. A pin in port 3 becomes an output port if the corresponding P3DDR bit is set to 1, and an input port if this bit is cleared to 0.

P3DDR is a write-only register. Its value cannot be read. All bits return 1 when read.

P3DDR is initialized to H'00 by a reset and in hardware standby mode. In software standby mode it retains its previous setting. Therefore, if a transition is made to software standby mode while port 3 is functioning as an input/output port and a P3DDR bit is set to 1, the corresponding pin maintains its output state.

**Port 3 Data Register (P3DR):** P3DR is an 8-bit readable/writable register that stores output data for port 3. When port 3 functions as an output port, the value of this register is output. When a bit in P3DDR is set to 1, if port 3 is read the value of the corresponding P3DR bit is returned. When a bit in P3DDR is cleared to 0, if port 3 is read the corresponding pin logic level is read.

Bit	7	6	5	4	3	2	1	0
	P3 <sub>7</sub>	P3 <sub>6</sub>	P3 <sub>5</sub>	P3 <sub>4</sub>	P3 <sub>3</sub>	P3 <sub>2</sub>	P3 <sub>1</sub>	P3 <sub>0</sub>
Initial value	0	0	0	0	0	0	0	0
Read/Write	R/W	R/W	R/W	R/W	R/W	R/W	R/W	R/W

**Port 3 data 7 to 0**

These bits store data for port 3 pins

P3DR is initialized to H'00 by a reset and in hardware standby mode. In software standby mode it retains its previous setting.



## 8.5 Port 4

### 8.5.1 Overview

Port 4 is an 8-bit input/output port with the pin configuration shown in figure 8.4. The pin functions differ depending on the operating mode.

In modes 1 to 5 (expanded modes), when the bus width control register (ABWCR) designates areas 0 to 7 all as 8-bit-access areas, the chip operates in 8-bit bus mode and port 4 is a generic input/output port. When at least one of areas 0 to 7 is designated as a 16-bit-access area, the chip operates in 16-bit bus mode and port 4 becomes part of the data bus. In mode 6, 7 (single-chip mode), port 4 is a generic input/output port.

Port 4 has software-programmable built-in pull-up transistors.

Pins in port 4 can drive one TTL load and a 90-pF capacitive load. They can also drive a darlington transistor pair.

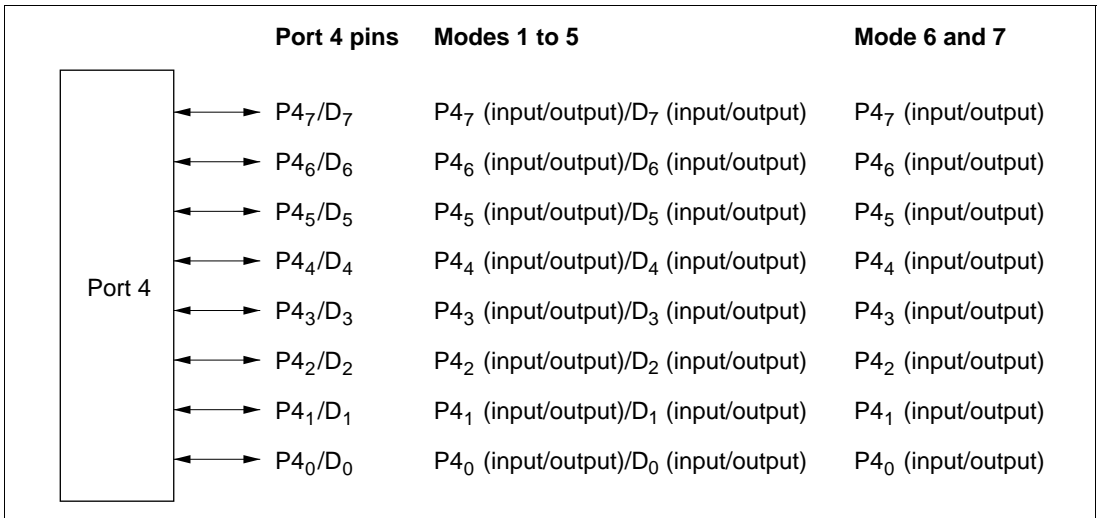


Figure 8.4 Port 4 Pin Configuration

## 8.5.2 Register Descriptions

Table 8.6 summarizes the registers of port 4.

**Table 8.6 Port 4 Registers**

Address*	Name	Abbreviation	R/W	Initial Value
H'EE003	Port 4 data direction register	P4DDR	W	H'00
H'FFFD3	Port 4 data register	P4DR	R/W	H'00
H'EE03E	Port 4 input pull-up control register	P4PCR	R/W	H'00

Note: \* Lower 20 bits of the address in advanced mode.

**Port 4 Data Direction Register (P4DDR):** P4DDR is an 8-bit write-only register that can select input or output for each pin in port 4.

Bit	7	6	5	4	3	2	1	0
	P4 <sub>7</sub> DDR	P4 <sub>6</sub> DDR	P4 <sub>5</sub> DDR	P4 <sub>4</sub> DDR	P4 <sub>3</sub> DDR	P4 <sub>2</sub> DDR	P4 <sub>1</sub> DDR	P4 <sub>0</sub> DDR
Initial value	0	0	0	0	0	0	0	0
Read/Write	W	W	W	W	W	W	W	W

### Port 4 data direction 7 to 0

These bits select input or output for port 4 pins

**Modes 1 to 5 (Expanded Modes):** When all areas are designated as 8-bit-access areas by the bus controller's bus width control register (ABWCR), selecting 8-bit bus mode, port 4 functions as an input/output port. In this case, a pin in port 4 becomes an output port if the corresponding P4DDR bit is set to 1, and an input port if this bit is cleared to 0.

When at least one area is designated as a 16-bit-access area, selecting 16-bit bus mode, port 4 functions as part of the data bus, regardless of the P4DDR settings.

**Mode 6 and 7 (Single-Chip Mode):** Port 4 functions as an input/output port. A pin in port 4 becomes an output port if the corresponding P4DDR bit is set to 1, and an input port if this bit is cleared to 0.

P4DDR is a write-only register. Its value cannot be read. All bits return 1 when read.

P4DDR is initialized to H'00 by a reset and in hardware standby mode. In software standby mode it retains its previous setting.

ABWCR and P4DDR are not initialized in software standby mode. Therefore, if a transition is made to software standby mode while port 4 is functioning as an input/output port and a P4DDR bit is set to 1, the corresponding pin maintains its output state.

**Port 4 Data Register (P4DR):** P4DR is an 8-bit readable/writable register that stores output data for port 4. When port 4 functions as an output port, the value of this register is output. When a bit in P4DDR is set to 1, if port 4 is read the value of the corresponding P4DR bit is returned. When a bit in P4DDR is cleared to 0, if port 4 is read the corresponding pin logic level is read.

Bit	7	6	5	4	3	2	1	0
	P4 <sub>7</sub>	P4 <sub>6</sub>	P4 <sub>5</sub>	P4 <sub>4</sub>	P4 <sub>3</sub>	P4 <sub>2</sub>	P4 <sub>1</sub>	P4 <sub>0</sub>
Initial value	0	0	0	0	0	0	0	0
Read/Write	R/W	R/W	R/W	R/W	R/W	R/W	R/W	R/W

**Port 4 data 7 to 0**  
 These bits store data for port 4 pins

P4DR is initialized to H'00 by a reset and in hardware standby mode. In software standby mode it retains its previous setting.

**Port 4 Input Pull-Up MOS Control Register (P4PCR):** P4PCR is an 8-bit readable/writable register that controls the MOS input pull-up transistors in port 4.

Bit	7	6	5	4	3	2	1	0
	P4 <sub>7</sub> PCR	P4 <sub>6</sub> PCR	P4 <sub>5</sub> PCR	P4 <sub>4</sub> PCR	P4 <sub>3</sub> PCR	P4 <sub>2</sub> PCR	P4 <sub>1</sub> PCR	P4 <sub>0</sub> PCR
Initial value	0	0	0	0	0	0	0	0
Read/Write	R/W	R/W	R/W	R/W	R/W	R/W	R/W	R/W

**Port 4 input pull-up control 7 to 0**  
 These bits control input pull-up transistors built into port 4

In mode 6 and 7 (single-chip mode), and in 8-bit bus mode in modes 1 to 5 (expanded modes), when a P4DDR bit is cleared to 0 (selecting generic input), if the corresponding P4PCR bit is set to 1, the input pull-up transistor is turned on.

P4PCR is initialized to H'00 by a reset and in hardware standby mode. In software standby mode it retains its previous setting.

Table 8.7 summarizes the states of the input pull-ups in each operating mode.

**Table 8.7 Input Pull-Up Transistor States (Port 4)**

<b>Mode</b>		<b>Reset</b>	<b>Hardware Standby Mode</b>	<b>Software Standby Mode</b>	<b>Other Modes</b>
1 to 5	8-bit bus mode	Off	Off	On/off	On/off
	16-bit bus mode			Off	Off
6 and 7				On/off	On/off

**Legend**

Off: The input pull-up transistor is always off.

On/off: The input pull-up transistor is on if P4PCR = 1 and P4DDR = 0. Otherwise, it is off.

## 8.6 Port 5

### 8.6.1 Overview

Port 5 is a 4-bit input/output port with the pin configuration shown in figure 8.5. The pin functions differ depending on the operating mode.

In modes 1 to 4 (expanded modes with on-chip ROM disabled), port 5 consists of address output pins ( $A_{19}$  to  $A_{16}$ ). In modes 5 (expanded modes with on-chip ROM enabled), settings in the port 5 data direction register (P5DDR) designate pins for address bus output ( $A_{19}$  to  $A_{16}$ ) or generic input. In mode 6, 7 (single-chip mode), port 5 is a generic input/output port.

Port 5 has software-programmable built-in pull-up transistors.

Pins in port 5 can drive one TTL load and a 90-pF capacitive load. They can also drive an LED or a darlington transistor pair.

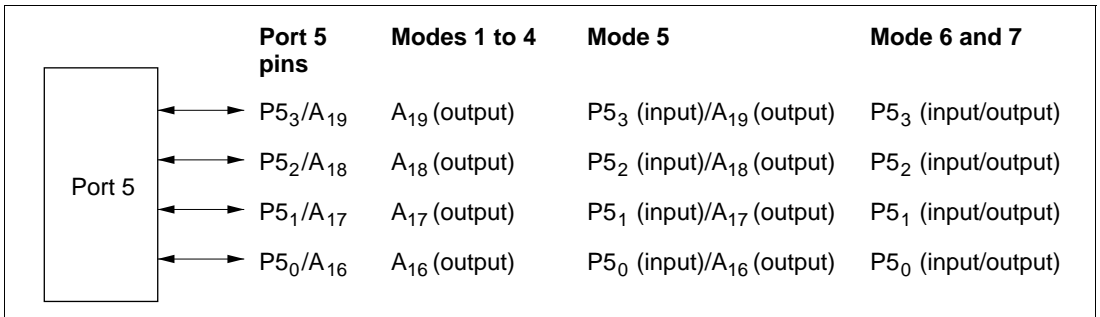


Figure 8.5 Port 5 Pin Configuration

### 8.6.2 Register Descriptions

Table 8.8 summarizes the registers of port 5.

Table 8.8 Port 5 Registers

Address*	Name	Abbreviation	R/W	Initial Value	
				Modes 1 to 4	Modes 5 to 7
H'EE004	Port 5 data direction register	P5DDR	W	H'FF	H'F0
H'FFFD4	Port 5 data register	P5DR	R/W	H'F0	H'F0
H'EE03F	Port 5 input pull-up control register	P5PCR	R/W	H'F0	H'F0

Note: \* Lower 20 bits of the address in advanced mode.

**Port 5 Data Direction Register (P5DDR):** P5DDR is an 8-bit write-only register that can select input or output for each pin in port 5.

Bits 7 to 4 are reserved. They are fixed at 1, and cannot be modified.

Bit	7	6	5	4	3	2	1	0
	—	—	—	—	P5 <sub>3</sub> DDR	P5 <sub>2</sub> DDR	P5 <sub>1</sub> DDR	P5 <sub>0</sub> DDR
Modes 1 to 4	Initial value	1	1	1	1	1	1	1
	Read/Write	—	—	—	—	—	—	—
Modes 5 to 7	Initial value	1	1	1	0	0	0	0
	Read/Write	—	—	—	W	W	W	W

**Reserved bits**

**Port 5 data direction 3 to 0**  
These bits select input or output for port 5 pins

**Modes 1 to 4 (Expanded Modes with On-Chip ROM Disabled):** P5DDR values are fixed at 1. Port 5 functions as an address bus.

**Modes 5 (Expanded Modes with On-Chip ROM Enabled):** Following a reset, port 5 is an input port. A pin in port 5 becomes an address output pin if the corresponding P5DDR bit is set to 1, and an input port if this bit is cleared to 0.

**Mode 6 and 7 (Single-Chip Mode):** Port 5 functions as an input/output port. A pin in port 5 becomes an output port if the corresponding P5DDR bit is set to 1, and an input port if this bit is cleared to 0.

In modes 1 to 4, P5DDR bits are always read as 1, and cannot be modified.

In modes 5 to 7, P5DDR is a write-only register. Its value cannot be read. All bits return 1 when read.

P5DDR is initialized to H'FF in modes 1 to 4, and to H'F0 in modes 5 to 7, by a reset and in hardware standby mode. In software standby mode it retains its previous setting. Therefore, if a transition is made to software standby mode while port 5 is functioning as an input/output port and a P5DDR bit is set to 1, the corresponding pin maintains its output state.

**Port 5 Data Register (P5DR):** P5DR is an 8-bit readable/writable register that stores output data for port 5. When port 5 functions as an output port, the value of this register is output. When a bit in P5DDR is set to 1, if port 5 is read the value of the corresponding P5DR bit is returned. When a bit in P5DDR is cleared to 0, if port 5 is read the corresponding pin logic level is read.

Bits 7 to 4 are reserved. They are fixed at 1, and cannot be modified.

Bit	7	6	5	4	3	2	1	0
	—	—	—	—	P5 <sub>3</sub>	P5 <sub>2</sub>	P5 <sub>1</sub>	P5 <sub>0</sub>
Initial value	1	1	1	1	0	0	0	0
Read/Write	—	—	—	—	R/W	R/W	R/W	R/W

**Reserved bits**
**Port 5 data 3 to 0**  
These bits store data for port 5 pins

P5DR is initialized to H'F0 by a reset and in hardware standby mode. In software standby mode it retains its previous setting.

**Port 5 Input Pull-Up MOS Control Register (P5PCR):** P5PCR is an 8-bit readable/writable register that controls the MOS input pull-up transistors in port 5.

Bits 7 to 4 are reserved. They are fixed at 1, and cannot be modified.

Bit	7	6	5	4	3	2	1	0
	—	—	—	—	P5 <sub>3</sub> PCR	P5 <sub>2</sub> PCR	P5 <sub>1</sub> PCR	P5 <sub>0</sub> PCR
Initial value	1	1	1	1	0	0	0	0
Read/Write	—	—	—	—	R/W	R/W	R/W	R/W

**Reserved bits**
**Port 5 input pull-up control 3 to 0**  
These bits control input pull-up transistors built into port 5

In modes 5 to 7, when a P5DDR bit is cleared to 0 (selecting generic input), if the corresponding bit in P5PCR is set to 1, the input pull-up transistor is turned on.

P5PCR is initialized to H'F0 by a reset and in hardware standby mode. In software standby mode it retains its previous setting.

Table 8.9 summarizes the states of the input pull-ups in each mode.

**Table 8.9 Input Pull-Up Transistor States (Port 5)**

<b>Mode</b>	<b>Reset</b>	<b>Hardware Standby Mode</b>	<b>Software Standby Mode</b>	<b>Other Modes</b>
1	Off	Off	Off	Off
2				
3				
4				
5	Off	Off	On/off	On/off
6				
7				

**Legend**

Off: The input pull-up transistor is always off.

On/off: The input pull-up transistor is on if P5PCR = 1 and P5DDR = 0. Otherwise, it is off.



## 8.7 Port 6

### 8.7.1 Overview

Port 6 is an 8-bit input/output port that is also used for input and output of bus control signals ( $\overline{LWR}$ ,  $\overline{HWR}$ ,  $\overline{RD}$ ,  $\overline{AS}$ ,  $\overline{BACK}$ ,  $\overline{BREQ}$ ,  $\overline{WAIT}$ ) and for clock ( $\phi$ ) output.

In modes 1 to 5 (expanded modes), the pin functions are  $P6_7$  (generic input)/ $\phi$ ,  $\overline{LWR}$ ,  $\overline{HWR}$ ,  $\overline{RD}$ ,  $\overline{AS}$ ,  $P6_2/\overline{BACK}$ ,  $P6_1/\overline{BREQ}$ , and  $P6_0/\overline{WAIT}$ . See table 8.11 for the selection of the pin functions. In modes 6 and 7 (single-chip modes),  $P6_7$  functions as a generic input port or  $\phi$  output, and  $P6_6$  to  $P6_0$  function as generic input/output ports.

When DRAM is connected to areas 2 to 5,  $\overline{LWR}$ ,  $\overline{HWR}$ , and  $\overline{RD}$  also function as  $\overline{LCAS}$ ,  $\overline{UCAS}$ , and  $\overline{WE}$ , respectively. For details see section 6.5, DRAM Interface.

Pins in port 6 can drive one TTL load and a 90-pF capacitive load. They can also drive a darlington transistor pair.

Port 6 pins	Modes 1 to 5 (expanded modes)	Mode 6 and 7 (single-chip mode)
$P6_7 / \phi$	$P6_7$ (input)/ $\phi$ (output)	$P6_7$ (input) / $\phi$ (output)
$P6_6 / \overline{LWR}$	$\overline{LWR}$ (output)	$P6_6$ (input/output)
$P6_5 / \overline{HWR}$	$\overline{HWR}$ (output)	$P6_5$ (input/output)
$P6_4 / \overline{RD}$	$\overline{RD}$ (output)	$P6_4$ (input/output)
$P6_3 / \overline{AS}$	$\overline{AS}$ (output)	$P6_3$ (input/output)
$P6_2 / \overline{BACK}$	$P6_2$ (input/output) $\overline{BACK}$ (output)	$P6_2$ (input/output)
$P6_1 / \overline{BREQ}$	$P6_1$ (input/output)/ $\overline{BREQ}$ (input)	$P6_1$ (input/output)
$P6_0 / \overline{WAIT}$	$P6_0$ (input/output)/ $\overline{WAIT}$ (input)	$P6_0$ (input/output)

Figure 8.6 Port 6 Pin Configuration

## 8.7.2 Register Descriptions

Table 8.10 summarizes the registers of port 6.

**Table 8.10 Port 6 Registers**

Address*	Name	Abbreviation	R/W	Initial Value
H'EE005	Port 6 data direction register	P6DDR	W	H'80
H'FFFD5	Port 6 data register	P6DR	R/W	H'80

Note: \* Lower 20 bits of the address in advanced mode.

**Port 6 Data Direction Register (P6DDR):** P6DDR is an 8-bit write-only register that can select input or output for each pin in port 6.

Bit 7 is reserved. It is fixed at 1, and cannot be modified.

Bit	7	6	5	4	3	2	1	0
	—	P6 <sub>6</sub> DDR	P6 <sub>5</sub> DDR	P6 <sub>4</sub> DDR	P6 <sub>3</sub> DDR	P6 <sub>2</sub> DDR	P6 <sub>1</sub> DDR	P6 <sub>0</sub> DDR
Initial value	1	0	0	0	0	0	0	0
Read/Write	—	W	W	W	W	W	W	W

Reserved bit

Port 6 data direction 6 to 0

These bits select input or output for port 6 pins

**Modes 1 to 5 (Expanded Modes):** P6<sub>7</sub> functions as the clock output pin ( $\phi$ ) or an input port. P6<sub>7</sub> is the clock output pin ( $\phi$ ) if the PSTOP bit in MSTRCH is cleared to 0 (initial value), and an input port if this bit is set to 1.

P6<sub>6</sub> to P6<sub>3</sub> function as bus control output pins ( $\overline{\text{LWR}}$ ,  $\overline{\text{HWR}}$ ,  $\overline{\text{RD}}$ , and  $\overline{\text{AS}}$ ), regardless of the settings of bits P6<sub>6</sub>DDR to P6<sub>3</sub>DDR.

P6<sub>2</sub> to P6<sub>0</sub> function as bus control input/output pins ( $\overline{\text{BACK}}$ ,  $\overline{\text{BREQ}}$ , and  $\overline{\text{WAIT}}$ ) or input/output ports. For the method of selecting the pin functions, see table 8.11.

When P6<sub>2</sub> to P6<sub>0</sub> function as input/output ports, the pin becomes an output port if the corresponding P6DDR bit is set to 1, and an input port if this bit is cleared to 0.

**Mode 6 and 7 (Single-Chip Mode):** P6<sub>7</sub> functions as the clock output pin ( $\phi$ ) or an input port. P6<sub>6</sub> to P6<sub>0</sub> function as generic input/output ports. P6<sub>7</sub> is the clock output pin ( $\phi$ ) if the PSTOP bit in MSTRCH is cleared to 0 (initial value), and an input port if this bit is set to 1. A pin in port 6 becomes an output port if the corresponding bit of P6<sub>6</sub>DDR to P6<sub>0</sub>DDR is set to 1, and an input port if this pin is cleared to 0.

P6DDR is a write-only register. Its value cannot be read. All bits return 1 when read.

P6DDR is initialized to H'80 by a reset and in hardware standby mode. In software standby mode it retains its previous setting. Therefore, if a transition is made to software standby mode while port 6 is functioning as an input/output port and a P6DDR bit is set to 1, the corresponding pin maintains its output state.

**Port 6 Data Register (P6DR):** P6DR is an 8-bit readable/writable register that stores output data for port 6. When port 6 functions as an output port, the value of this register is output. For bit 7, a value of 1 is returned if the bit is read while the PSTOP bit in MSTCRH is cleared to 0, and the P67 pin logic level is returned if the bit is read while the PSTOP bit is set to 1. Bit 7 cannot be modified. For bits 6 to 0, the pin logic level is returned if the bit is read while the corresponding bit in P6DDR is cleared to 0, and the P6DR value is returned if the bit is read while the corresponding bit in P6DDR is set to 1.

Bit	7	6	5	4	3	2	1	0
	P6 <sub>7</sub>	P6 <sub>6</sub>	P6 <sub>5</sub>	P6 <sub>4</sub>	P6 <sub>3</sub>	P6 <sub>2</sub>	P6 <sub>1</sub>	P6 <sub>0</sub>
Initial value	1	0	0	0	0	0	0	0
Read/Write	R	R/W	R/W	R/W	R/W	R/W	R/W	R/W

**Port 6 data 7 to 0**

These bits store data for port 6 pins

P6DR is initialized to H'80 by a reset and in hardware standby mode. In software standby mode it retains its previous setting.

**Table 8.11 Port 6 Pin Functions in Modes 1 to 5**

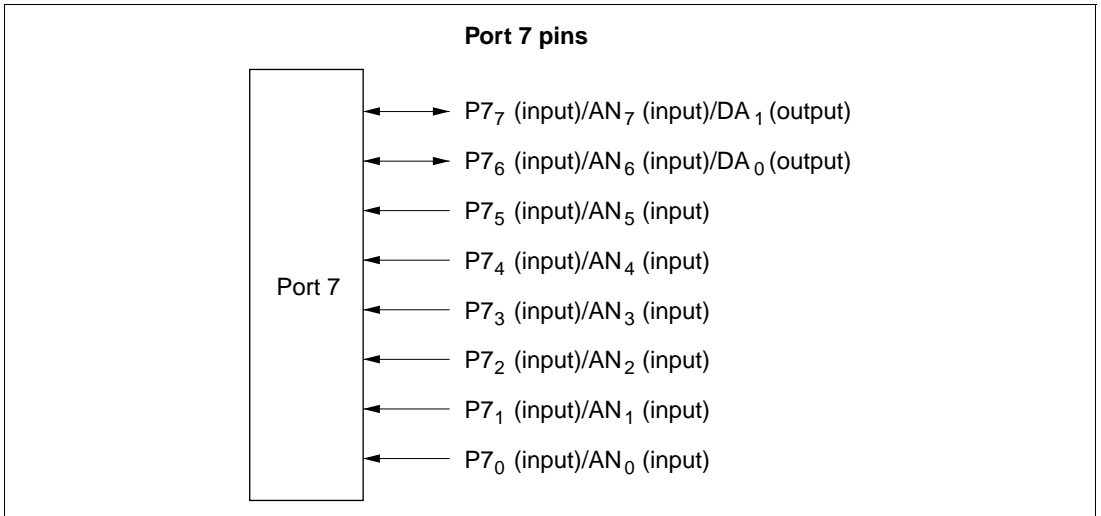
Pin	Pin Functions and Selection Method		
P6 <sub>7</sub> /φ	Bit PSTOP in MSTCRH selects the pin function.		
	PSTOP	0	1
	Pin function	φ output	
LWR	Functions as $\overline{LWR}$ regardless of the setting of bit P6 <sub>6</sub> DDR		
	P6 <sub>6</sub> DDR	0	1
	Pin function	$\overline{LWR}$ output*	
Note: * If any of bits DRAS2 to DRAS0 in DRCRA is 1 and bit CSEL in DRCRB is 1, $\overline{LWR}$ output functions as LCAS.			
HWR	Functions as $\overline{HWR}$ regardless of the setting of bit P6 <sub>5</sub> DDR		
	P6 <sub>5</sub> DDR	0	1
	Pin function	$\overline{HWR}$ output*	
Note: * If any of bits DRAS2 to DRAS0 in DRCRA is 1 and bit CSEL in DRCRB is 1, $\overline{HWR}$ output functions as $\overline{UCAS}$ .			
$\overline{RD}$	Functions as $\overline{RD}$ regardless of the setting of bit P6 <sub>4</sub> DDR		
	P6 <sub>4</sub> DDR	0	1
	Pin function	$\overline{RD}$ output*	
Note: * If any of bits DRAS2 to DRAS0 in DRCRA is 1, $\overline{RD}$ output functions as $\overline{WE}$ .			
$\overline{AS}$	Functions as $\overline{AS}$ regardless of the setting of bit P6 <sub>3</sub> DDR		
	P6 <sub>3</sub> DDR	0	1
	Pin function	$\overline{AS}$ output	
P6 <sub>2</sub> / $\overline{BACK}$	Bit BRLE in BRCCR and bit P6 <sub>2</sub> DDR select the pin function as follows		
	BRLE	0	1
	P6 <sub>2</sub> DDR	0	1
	Pin function	P6 <sub>2</sub> input	P6 <sub>2</sub> output
P6 <sub>1</sub> / $\overline{BREQ}$	Bit BRLE in BRCCR and bit P6 <sub>1</sub> DDR select the pin function as follows		
	BRLE	0	1
	P6 <sub>1</sub> DDR	0	1
	Pin function	P6 <sub>1</sub> input	P6 <sub>1</sub> output
P6 <sub>0</sub> / $\overline{WAIT}$	Bit WAITE in BCR and bit P6 <sub>0</sub> DDR select the pin function as follows.		
	WAITE	0	1
	P6 <sub>0</sub> DDR	0	1
	Pin function	P6 <sub>0</sub> input	P6 <sub>0</sub> output
Note: * Do not set bit P6 <sub>0</sub> DDR to 1.			

## 8.8 Port 7

### 8.8.1 Overview

Port 7 is an 8-bit input port that is also used for analog input to the A/D converter and analog output from the D/A converter. The pin functions are the same in all operating modes. Figure 8.7 shows the pin configuration of port 7.

See section 15, A/D Converter, for details of the A/D converter analog input pins, and section 16, D/A Converter, for details of the D/A converter analog output pins.



**Figure 8.7 Port 7 Pin Configuration**

## 8.8.2 Register Description

Table 8.12 summarizes the port 7 register. Port 7 is an input port, and port 7 has no data direction register.

**Table 8.12 Port 7 Data Register**

Address*	Name	Abbreviation	R/W	Initial Value
H'FFFD6	Port 7 data register	P7DR	R	Undetermined

Note: \* Lower 20 bits of the address in advanced mode.

### Port 7 Data Register (P7DR)

Bit	7	6	5	4	3	2	1	0
	P7 <sub>7</sub>	P7 <sub>6</sub>	P7 <sub>5</sub>	P7 <sub>4</sub>	P7 <sub>3</sub>	P7 <sub>2</sub>	P7 <sub>1</sub>	P7 <sub>0</sub>
Initial value	—*	—*	—*	—*	—*	—*	—*	—*
Read/Write	R	R	R	R	R	R	R	R

Note: \* Determined by pins P7<sub>7</sub> to P7<sub>0</sub>.

When port 7 is read, the pin logic levels are always read. P7DR cannot be modified.

## 8.9 Port 8

### 8.9.1 Overview

Port 8 is a 5-bit input/output port that is also used for  $\overline{CS}_3$  to  $\overline{CS}_0$  output,  $\overline{RFSH}$  output,  $\overline{IRQ}_3$  to  $\overline{IRQ}_0$  input, and A/D converter  $\overline{ADTRG}$  input. Figure 8.8 shows the pin configuration of port 8.

In modes 1 to 5 (expanded modes), port 8 can provide  $\overline{CS}_3$  to  $\overline{CS}_0$  output,  $\overline{RFSH}$  output,  $\overline{IRQ}_3$  to  $\overline{IRQ}_0$  input, and  $\overline{ADTRG}$  input. See table 8.14 for the selection of pin functions in expanded modes.

In modes 6 and 7 (single-chip modes), port 8 can provide  $\overline{IRQ}_3$  to  $\overline{IRQ}_0$  input and  $\overline{ADTRG}$  input. See table 8.15 for the selection of pin functions in single-chip mode.

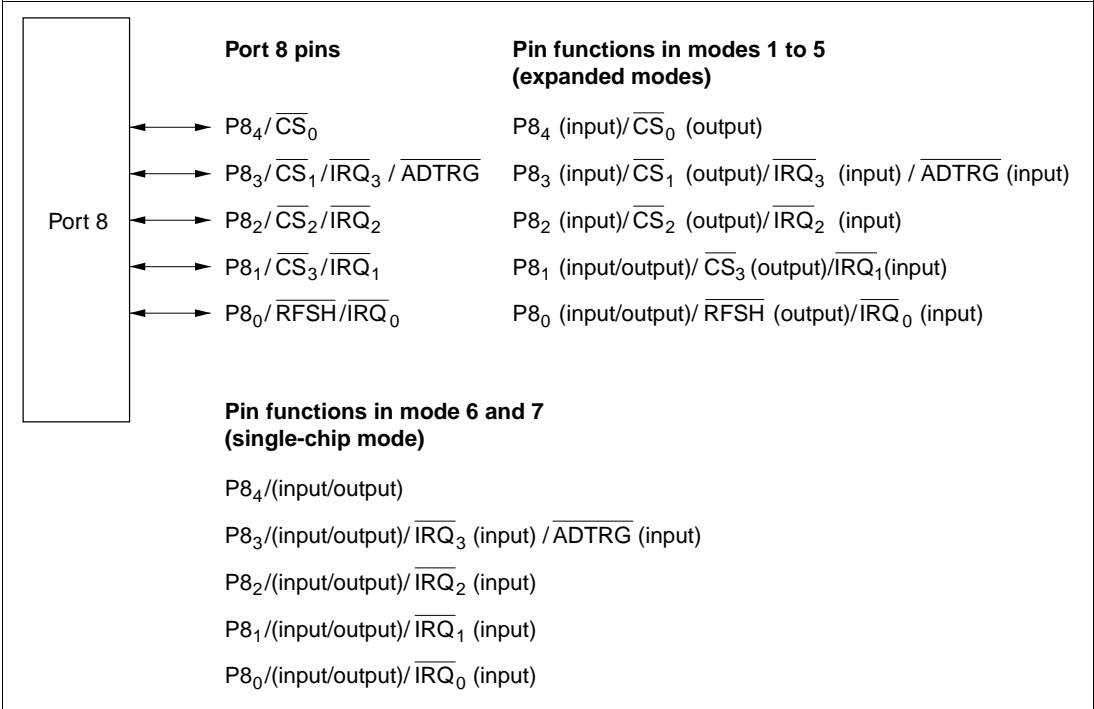
See section 15, A/D Converter, for a description of the A/D converter's  $\overline{ADTRG}$  input pin.

The  $\overline{IRQ}_3$  to  $\overline{IRQ}_0$  functions are selected by IER settings, regardless of whether the pin is used for input or output. Caution is therefore required. For details see section 5.3.1, External Interrupts.

When DRAM is connected to areas 2 to 5, the  $\overline{CS}_3$  and  $\overline{CS}_2$  output pins function as  $\overline{RAS}$  output pins for each area. For details see section 6.5, DRAM Interface.

Pins in port 8 can drive one TTL load and a 90-pF capacitive load. They can also drive a darlington transistor pair.

Pins P8<sub>2</sub> to P8<sub>0</sub> have Schmitt-trigger inputs.



**Figure 8.8 Port 8 Pin Configuration**



## 8.9.2 Register Descriptions

Table 8.13 summarizes the registers of port 8.

**Table 8.13 Port 8 Registers**

Address*	Name	Abbreviation	R/W	Initial Value	
				Mode 1 to 4	Mode 5 to 7
H'EE007	Port 8 data direction register	P8DDR	W	H'F0	H'E0
H'FFFD7	Port 8 data register	P8DR	R/W	H'E0	H'E0

Note: \* Lower 20 bits of the address in advanced mode.

**Port 8 Data Direction Register (P8DDR):** P8DDR is an 8-bit write-only register that can select input or output for each pin in port 8.

Bits 7 to 5 are reserved. They are fixed at 1, and cannot be modified.

Bit		7	6	5	4	3	2	1	0
		—	—	—	P8 <sub>4</sub> DDR	P8 <sub>3</sub> DDR	P8 <sub>2</sub> DDR	P8 <sub>1</sub> DDR	P8 <sub>0</sub> DDR
Modes 1 to 4	Initial value	1	1	1	1	0	0	0	0
	Read/Write	—	—	—	W	W	W	W	W
Modes 5 to 7	Initial value	1	1	1	0	0	0	0	0
	Read/Write	—	—	—	W	W	W	W	W

Reserved bits

**Port 8 data direction 4 to 0**  
These bits select input or output for port 8 pins

**Modes 1 to 5 (Expanded Modes):** When bits in P8DDR bit are set to 1, P8<sub>4</sub> to P8<sub>1</sub> become  $\overline{CS}_0$  to  $\overline{CS}_3$  output pins. When bits in P8DDR are cleared to 0, the corresponding pins become input ports. However, P8<sub>1</sub> can also be used as an output port, depending on the setting of bits DRAS2 to DRAS0 in DRAM control register A (DRCRA). For details see section 6.5.2, DRAM Space and  $\overline{RAS}$  Output Pin Settings.

In modes 1 to 4 (expanded modes with on-chip ROM disabled), following a reset P8<sub>4</sub> functions as the  $\overline{CS}_0$  output, while  $\overline{CS}_1$  to  $\overline{CS}_3$  are input ports. In mode 5 (expanded mode with on-chip ROM enabled), following a reset  $\overline{CS}_0$  to  $\overline{CS}_3$  are all input ports.

When the refresh enable bit (RFSHE) in DRCRA is set to 1, P8<sub>0</sub> is used for  $\overline{RFSH}$  output. When RFSHE is cleared to 0, P8<sub>0</sub> becomes an input/output port according to the P8DDR setting. For details see table 8.14.

**Mode 6 and 7 (Single-Chip Mode):** Port 8 is a generic input/output port. A pin in port 8 becomes an output port if the corresponding P8DDR bit is set to 1, and an input port if this bit is cleared to 0.

P8DDR is a write-only register. Its value cannot be read. All bits return 1 when read.

P8DDR is initialized to H'F0 in modes 1 to 4, and to H'E0 in modes 5 to 7, by a reset and in hardware standby mode. In software standby mode P8DDR retains its previous setting. Therefore, if a transition is made to software standby mode while port 8 is functioning as an input/output port and a P8DDR bit is set to 1, the corresponding pin maintains its output state.

**Port 8 Data Register (P8DR):** P8DR is an 8-bit readable/writable register that stores output data for port 8. When port 8 functions as an output port, the value of this register is output. When a bit in P8DDR is set to 1, if port 8 is read the value of the corresponding P8DR bit is returned. When a bit in P8DDR is cleared to 0, if port 8 is read the corresponding pin logic level is read.

Bits 7 to 5 are reserved. They are fixed at 1, and cannot be modified.

Bit	7	6	5	4	3	2	1	0
	—	—	—	P8 <sub>4</sub>	P8 <sub>3</sub>	P8 <sub>2</sub>	P8 <sub>1</sub>	P8 <sub>0</sub>
Initial value	1	1	1	0	0	0	0	0
Read/Write	—	—	—	R/W	R/W	R/W	R/W	R/W

Reserved bits

**Port 8 data 4 to 0**  
These bits store data for port 8 pins

P8DR is initialized to H'E0 by a reset and in hardware standby mode. In software standby mode it retains its previous setting.

**Table 8.14 Port 8 Pin Functions in Modes 1 to 5**

Pin	Pin Functions and Selection Method								
$P8_4/\overline{CS}_0$	Bit P8 <sub>4</sub> DDR selects the pin function as follows								
	P8 <sub>4</sub> DDR	0	1						
	Pin function	P8 <sub>4</sub> input	$\overline{CS}_0$ output						
$P8_3/\overline{CS}_1/\overline{IRQ}_3/\overline{ADTRG}$	Bit P8 <sub>3</sub> DDR selects the pin function as follows								
	P8 <sub>3</sub> DDR	0	1						
	Pin function	P8 <sub>3</sub> input	$\overline{CS}_1$ output						
		$\overline{IRQ}_3$ input							
$\overline{ADTRG}$ input									
$P8_2/\overline{CS}_2/\overline{IRQ}_2$	The DRAM interface settings by bits DRAS2 to DRAS0 in DRCRA, and bit P8 <sub>2</sub> DDR, select the pin function as follows.								
	DRAM interface settings	(1) in table below	((2) in table below						
	P8 <sub>2</sub> DDR	0	1	—					
	Pin function	P8 <sub>2</sub> input	$\overline{CS}_2$ output	$\overline{CS}_2$ output*					
$\overline{IRQ}_2$ input									
Note: * $\overline{CS}_2$ is output as $\overline{RAS}_2$ .									
$P8_1/\overline{CS}_3/\overline{IRQ}_1$	DRAM interface setting	(1)	(2)						
	DRAS2	0			1				
	DRAS1	0	1	0	1	0	1		
	DRAS0	0	1	0	1	0	1	0	1
	DRAM interface settings	(1) in table below		(2) in table below		(3) in table below			
P8 <sub>1</sub> DDR	0	1	0	1	—				
Pin function	P8 <sub>1</sub> input pin	$\overline{CS}_3$ output pin	P8 <sub>1</sub> input pin	P8 <sub>1</sub> output pin	$\overline{CS}_3$ output pin*				
	$\overline{IRQ}_1$ input pin								
Note: * $\overline{CS}_3$ is output as $\overline{RAS}_3$ .									
$P8_0/\overline{RFSH}/\overline{IRQ}_0$	DRAM interface setting	(1)	(3)	(2)	(3)	(2)			
	DRAS2	0			1				
	DRAS1	0	1	0	1	0	1		
	DRAS0	0	1	0	1	0	1	0	1
	RFSHE	0			1*				
P8 <sub>0</sub> DDR	0	1	—						
Pin function	P8 <sub>0</sub> input	P8 <sub>0</sub> output	$\overline{RFSH}$ output						
	$\overline{IRQ}_0$ input								
Note: * If areas 2 to 5 are not designated as DRAM space, this bit should not be set to 1.									

**Table 8.15 Port 8 Pin Functions in Mode 6 and 7**

**Pin Pin Functions and Selection Method**

P8 <sub>4</sub>	Bit P8 <sub>4</sub> DDR selects the pin function as follows		
	P8 <sub>4</sub> DDR	0	1
	Pin function	P8 <sub>4</sub> input	P8 <sub>4</sub> output

P8 <sub>3</sub> $\overline{\text{IRQ}}_3$ $\overline{\text{ADTRG}}$	Bit P8 <sub>3</sub> DDR selects the pin function as follows		
	P8 <sub>3</sub> DDR	0	1
	Pin function	P8 <sub>3</sub> input	P8 <sub>3</sub> output
		$\overline{\text{IRQ}}_3$ input	
$\overline{\text{ADTRG}}$ input			

P8 <sub>2</sub> $\overline{\text{IRQ}}_2$	Bit P8 <sub>2</sub> DDR selects the pin function as follows		
	P8 <sub>2</sub> DDR	0	1
	Pin function	P8 <sub>2</sub> input	P8 <sub>2</sub> output
$\overline{\text{IRQ}}_2$ input			

P8 <sub>1</sub> $\overline{\text{IRQ}}_1$	Bit P8 <sub>1</sub> DDR selects the pin function as follows		
	P8 <sub>1</sub> DDR	0	1
	Pin function	P8 <sub>1</sub> input	P8 <sub>1</sub> output
$\overline{\text{IRQ}}_1$ input			

P8 <sub>0</sub> $\overline{\text{IRQ}}_0$	Bit P8 <sub>0</sub> DDR select the pin function as follows		
	P8 <sub>0</sub> DDR	0	1
	Pin function	P8 <sub>0</sub> input	P8 <sub>0</sub> output
$\overline{\text{IRQ}}_0$ input			

## 8.10 Port 9

### 8.10.1 Overview

Port 9 is a 6-bit input/output port that is also used for input and output (TxD<sub>0</sub>, TxD<sub>1</sub>, RxD<sub>0</sub>, RxD<sub>1</sub>, SCK<sub>0</sub>, SCK<sub>1</sub>) by serial communication interface channels 0 and 1 (SCI0 and SCI1), and for  $\overline{\text{IRQ}}_5$  and  $\overline{\text{IRQ}}_4$  input. See table 8.17 for the selection of pin functions.

The  $\overline{\text{IRQ}}_5$  and  $\overline{\text{IRQ}}_4$  functions are selected by IER settings, regardless of whether the pin is used for input or output. Caution is therefore required. For details see section 5.3.1, External Interrupts.

Port 9 has the same set of pin functions in all operating modes. Figure 8.9 shows the pin configuration of port 9.

Pins in port 9 can drive one TTL load and a 30-pF capacitive load. They can also drive a darlington transistor pair.

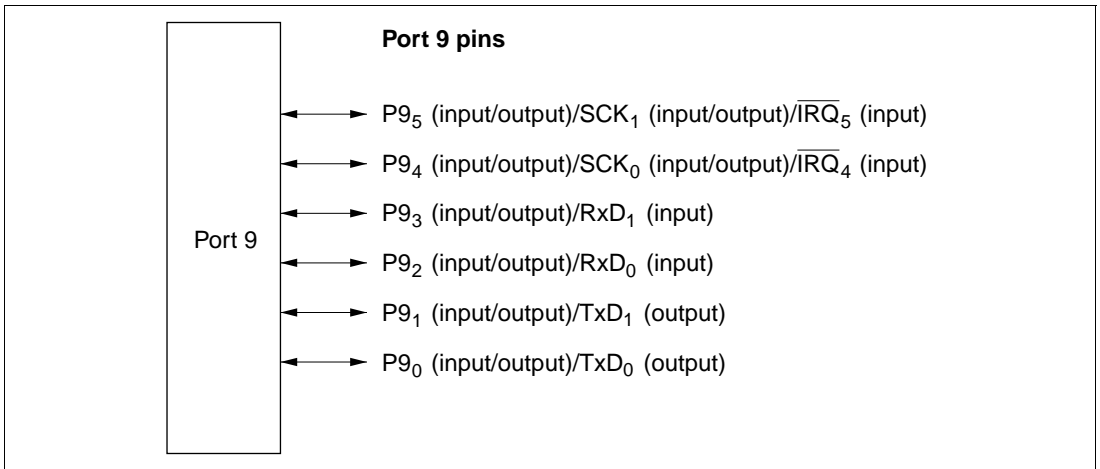


Figure 8.9 Port 9 Pin Configuration

## 8.10.2 Register Descriptions

Table 8.16 summarizes the registers of port 9.

**Table 8.16 Port 9 Registers**

Address*	Name	Abbreviation	R/W	Initial Value
H'EE08	Port 9 data direction register	P9DDR	W	H'C0
H'FFFD8	Port 9 data register	P9DR	R/W	H'C0

Note: \* Lower 20 bits of the address in advanced mode.

**Port 9 Data Direction Register (P9DDR):** P9DDR is an 8-bit write-only register that can select input or output for each pin in port 9.

Bits 7 and 6 are reserved. They are fixed at 1, and cannot be modified.

Bit	7	6	5	4	3	2	1	0
	—	—	P9 <sub>5</sub> DDR	P9 <sub>4</sub> DDR	P9 <sub>3</sub> DDR	P9 <sub>2</sub> DDR	P9 <sub>1</sub> DDR	P9 <sub>0</sub> DDR
Initial value	1	1	0	0	0	0	0	0
Read/Write	—	—	W	W	W	W	W	W

**Reserved bits**
**Port 9 data direction 5 to 0**  
These bits select input or output for port 9 pins

When port 9 functions as an input/output port, a pin in port 9 becomes an output port if the corresponding P9DDR bit is set to 1, and an input port if this bit is cleared to 0. For the method of selecting the pin functions, see table 8.17.

P9DDR is a write-only register. Its value cannot be read. All bits return 1 when read.

P9DDR is initialized to H'C0 by a reset and in hardware standby mode. In software standby mode it retains its previous setting. Therefore, if a transition is made to software standby mode while port 9 is functioning as an input/output port and a P9DDR bit is set to 1, the corresponding pin maintains its output state.

**Port 9 Data Register (P9DR):** P9DR is an 8-bit readable/writable register that stores output data for port 9. When port 9 functions as an output port, the value of this register is output. When a bit in P9DDR is set to 1, if port 9 is read the value of the corresponding P9DR bit is returned. When a bit in P9DDR is cleared to 0, if port 9 is read the corresponding pin logic level is read.

Bits 7 and 6 are reserved. They are fixed at 1, and cannot be modified.

Bit	7	6	5	4	3	2	1	0
	—	—	P9 <sub>5</sub>	P9 <sub>4</sub>	P9 <sub>3</sub>	P9 <sub>2</sub>	P9 <sub>1</sub>	P9 <sub>0</sub>
Initial value	1	1	0	0	0	0	0	0
Read/Write	—	—	R/W	R/W	R/W	R/W	R/W	R/W

**Reserved bits**

**Port 9 data 5 to 0**  
These bits store data  
for port 9 pins

P9DR is initialized to H'C0 by a reset and in hardware standby mode. In software standby mode it retains its previous setting.

**Table 8.17 Port 9 Pin Functions**
**Pin Pin Functions and Selection Method**
 $P9_5/SCK_5/\overline{IRQ}_5$ 

 Bit  $C/\overline{A}$  in SMR of SCI1, bits CKE0 and CKE1 in SCR, and bit  $P9_5$ DDR select the pin function as follows

CKE1	0			1
$C/\overline{A}$	0		1	—
CKE0	0	1	—	—
$P9_5$ DDR	0	1	—	—
Pin function	$P9_5$ input	$P9_5$ output	$SCK_5$ output	$SCK_5$ output
	$\overline{IRQ}_5$ input			

 $P9_4/SCK_4/\overline{IRQ}_4$ 

 Bit  $C/\overline{A}$  in SMR of SCI0, bits CKE0 and CKE1 in SCR, and bit  $P9_4$ DDR select the pin function as follows

CKE1	0			1
$C/\overline{A}$	0		1	—
CKE0	0	1	—	—
$P9_4$ DDR	0	1	—	—
Pin function	$P9_4$ input	$P9_4$ output	$SCK_4$ output	$SCK_4$ output
	$\overline{IRQ}_4$ input			

 $P9_3/RxD_1$ 

 Bit RE in SCR of SCI1, bit SMIF in SCMR, and bit  $P9_3$ DDR select the pin function as follows.

SMIF	0			1
RE	0		1	—
$P9_3$ DDR	0	1	—	—
Pin function	$P9_3$ input	$P9_3$ output	$RxD_1$ input	$RxD_1$ input

 $P9_2/RxD_0$ 

 Bit RE in SCR of SCI0, bit SMIF in SCMR, and bit  $P9_2$ DDR select the pin function as follows

SMIF	0			1
RE	0		1	—
$P9_2$ DDR	0	1	—	—
Pin function	$P9_2$ input	$P9_2$ output	$RxD_0$ input	$RxD_0$ input



**Table 8.17 Port 9 Pin Functions (cont)**

Pin	Pin Functions and Selection Method			
P9 <sub>1</sub> /TxD <sub>1</sub>	Bit TE in SCR of SCI1, bit SMIF in SCMR, and bit P9 <sub>1</sub> DDR select the pin function as follows.			
	SMIF	0		1
	TE	0		1
	P9 <sub>1</sub> DDR	0	1	—
	Pin function	P9 <sub>1</sub> input	P9 <sub>1</sub> output	TxD <sub>1</sub> output
Note: * Functions as the TxD <sub>1</sub> output pin, but there are two states: one in which the pin is driven, and another in which the pin is at high-impedance.				
P9 <sub>0</sub> /TxD <sub>0</sub>	Bit TE in SCR of SCI0, bit SMIF in SCMR, and bit P9 <sub>0</sub> DDR select the pin function as follows.			
	SMIF	0		1
	TE	0		1
	P9 <sub>0</sub> DDR	0	1	—
	Pin function	P9 <sub>0</sub> input	P9 <sub>0</sub> output	TxD <sub>0</sub> output
Note: * Functions as the TxD <sub>0</sub> output pin, but there are two states: one in which the pin is driven, and another in which the pin is at high impedance.				

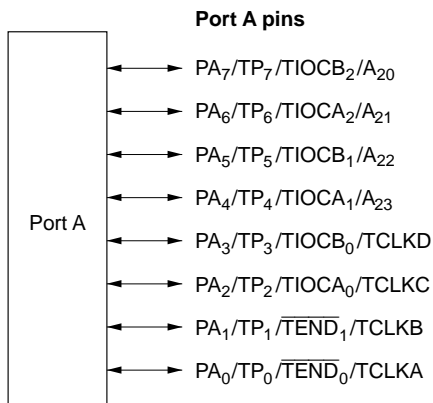
## 8.11 Port A

### 8.11.1 Overview

Port A is an 8-bit input/output port that is also used for output (TP<sub>7</sub> to TP<sub>0</sub>) from the programmable timing pattern controller (TPC), input and output, (TIOCB<sub>2</sub>, TIOCA<sub>2</sub>, TIOCB<sub>1</sub>, TIOCA<sub>1</sub>, TIOCB<sub>0</sub>, TIOCA<sub>0</sub>, TCLKD, TCLKC, TCLKB, TCLKA) by the 16-bit timer, input (TCLKD, TCLKC, TCLKB, TCLKA) to the 8-bit timer, output ( $\overline{\text{TEND}}_1$ ,  $\overline{\text{TEND}}_0$ ) from the DMA controller (DMAC), and address output (A<sub>23</sub> to A<sub>20</sub>). A reset or hardware standby transition leaves port A as an input port, except that in modes 3 and 4, one pin is always used for A<sub>20</sub> output. See table 8.19 to 8.21 for the selection of pin functions.

Usage of pins for TPC, 16-bit timer, 8-bit timer, and DMAC input and output is described in the sections on those modules. For output of address bits A<sub>23</sub> to A<sub>20</sub> in modes 3, 4, and 5, see section 6.2.4, Bus Release Control Register (BRCR). Pins not assigned to any of these functions are available for generic input/output. Figure 8.10 shows the pin configuration of port A.

Pins in port A can drive one TTL load and a 30-pF capacitive load. They can also drive a darlington transistor pair. Port A has Schmitt-trigger inputs.



**Pin functions in modes 1, 2, 6 and 7**

PA<sub>7</sub> (input/output)/TP<sub>7</sub> (output)/TIOCB<sub>2</sub> (input/output)  
 PA<sub>6</sub> (input/output)/TP<sub>6</sub> (output)/TIOCA<sub>2</sub> (input/output)  
 PA<sub>5</sub> (input/output)/TP<sub>5</sub> (output)/TIOCB<sub>1</sub> (input/output)  
 PA<sub>4</sub> (input/output)/TP<sub>4</sub> (output)/TIOCA<sub>1</sub> (input/output)  
 PA<sub>3</sub> (input/output)/TP<sub>3</sub> (output)/TIOCB<sub>0</sub> (input/output)/TCLKD (input)  
 PA<sub>2</sub> (input/output)/TP<sub>2</sub> (output)/TIOCA<sub>0</sub> (input/output)/TCLKC (input)  
 PA<sub>1</sub> (input/output)/TP<sub>1</sub> (output)/ $\overline{\text{TEND}}_1$  (output)/TCLKB (input)  
 PA<sub>0</sub> (input/output)/TP<sub>0</sub> (output)/ $\overline{\text{TEND}}_0$  (output)/TCLKA (input)

**Pin functions in modes 3, 4**

A<sub>20</sub> (output)  
 PA<sub>6</sub> (input/output)/TP<sub>6</sub> (output)/TIOCA<sub>2</sub> (input/output)/A<sub>21</sub> (output)  
 PA<sub>5</sub> (input/output)/TP<sub>5</sub> (output)/TIOCB<sub>1</sub> (input/output)/A<sub>22</sub> (output)  
 PA<sub>4</sub> (input/output)/TP<sub>4</sub> (output)/TIOCA<sub>1</sub> (input/output)/A<sub>23</sub> (output)  
 PA<sub>3</sub> (input/output)/TP<sub>3</sub> (output)/TIOCB<sub>0</sub> (input/output)/TCLKD (input)  
 PA<sub>2</sub> (input/output)/TP<sub>2</sub> (output)/TIOCA<sub>0</sub> (input/output)/TCLKC (input)  
 PA<sub>1</sub> (input/output)/TP<sub>1</sub> (output)/ $\overline{\text{TEND}}_1$  (output)/TCLKB (input)  
 PA<sub>0</sub> (input/output)/TP<sub>0</sub> (output)/ $\overline{\text{TEND}}_0$  (output)/TCLKA (input)

**Pin functions in mode 5**

PA<sub>7</sub> (input/output)/TP<sub>7</sub> (output)/TIOCB<sub>2</sub> (input/output)/A<sub>20</sub> (output)  
 PA<sub>6</sub> (input/output)/TP<sub>6</sub> (output)/TIOCA<sub>2</sub> (input/output)/A<sub>21</sub> (output)  
 PA<sub>5</sub> (input/output)/TP<sub>5</sub> (output)/TIOCB<sub>1</sub> (input/output)/A<sub>22</sub> (output)  
 PA<sub>4</sub> (input/output)/TP<sub>4</sub> (output)/TIOCA<sub>1</sub> (input/output)/A<sub>23</sub> (output)  
 PA<sub>3</sub> (input/output)/TP<sub>3</sub> (output)/TIOCB<sub>0</sub> (input/output)/TCLKD (input)  
 PA<sub>2</sub> (input/output)/TP<sub>2</sub> (output)/TIOCA<sub>0</sub> (input/output)/TCLKC (input)  
 PA<sub>1</sub> (input/output)/TP<sub>1</sub> (output)/ $\overline{\text{TEND}}_1$  (output)/TCLKB (input)  
 PA<sub>0</sub> (input/output)/TP<sub>0</sub> (output)/ $\overline{\text{TEND}}_0$  (output)/TCLKA (input)

**Figure 8.10 Port A Pin Configuration**

## 8.11.2 Register Descriptions

Table 8.18 summarizes the registers of port A.

**Table 8.18 Port A Registers**

Address*	Name	R/W	Initial Value		
			Modes 1, 2, 5, 6 and 7	Modes 3, 4	
H'EE009	Port A data direction register	PADDR	W	H'00	H'80
H'FFFD9	Port A data register	PADR	R/W	H'00	H'00

Note: \* Lower 20 bits of the address in advanced mode.

**Port A Data Direction Register (PADDR):** PADDR is an 8-bit write-only register that can select input or output for each pin in port A. When pins are used for TPC output, the corresponding PADDR bits must also be set.

Bit		7	6	5	4	3	2	1	0
		PA <sub>7</sub> DDR	PA <sub>6</sub> DDR	PA <sub>5</sub> DDR	PA <sub>4</sub> DDR	PA <sub>3</sub> DDR	PA <sub>2</sub> DDR	PA <sub>1</sub> DDR	PA <sub>0</sub> DDR
Modes 3, 4	Initial value	1	0	0	0	0	0	0	0
	Read/Write	—	W	W	W	W	W	W	W
Modes 1, 2, 5, 6 and 7	Initial value	0	0	0	0	0	0	0	0
	Read/Write	W	W	W	W	W	W	W	W

### Port A data direction 7 to 0

These bits select input or output for port A pins

The pin functions that can be selected for pins PA<sub>7</sub> to PA<sub>4</sub> differ between modes 1, 2, 6, and 7, and modes 3 to 5. For the method of selecting the pin functions, see tables 8.19 and 8.20.

The pin functions that can be selected for pins PA<sub>3</sub> to PA<sub>0</sub> are the same in modes 1 to 7. For the method of selecting the pin functions, see table 8.21.

When port A functions as an input/output port, a pin in port A becomes an output port if the corresponding PADDR bit is set to 1, and an input port if this bit is cleared to 0. In modes 3 and 4, PA<sub>7</sub>DDR is fixed at 1 and PA<sub>7</sub> functions as the A<sub>20</sub> address output pin.

PADDR is a write-only register. Its value cannot be read. All bits return 1 when read.

PADDR is initialized to H'00 by a reset and in hardware standby mode in modes 1, 2, 5, 6, and 7. It is initialized to H'80 by a reset and in hardware standby mode in modes 3 and 4. In software standby mode it retains its previous setting. Therefore, if a transition is made to software standby

mode while port A is functioning as an input/output port and a PADDR bit is set to 1, the corresponding pin maintains its output state.

**Port A Data Register (PADR):** PADR is an 8-bit readable/writable register that stores output data for port A. When port A functions as an output port, the value of this register is output. When a bit in PADDR is set to 1, if port A is read the value of the corresponding PADR bit is returned. When a bit in PADDR is cleared to 0, if port A is read the corresponding pin logic level is read.

Bit	7	6	5	4	3	2	1	0
	PA <sub>7</sub>	PA <sub>6</sub>	PA <sub>5</sub>	PA <sub>4</sub>	PA <sub>3</sub>	PA <sub>2</sub>	PA <sub>1</sub>	PA <sub>0</sub>
Initial value	0	0	0	0	0	0	0	0
Read/Write	R/W	R/W	R/W	R/W	R/W	R/W	R/W	R/W

**Port A data 7 to 0**

These bits store data for port A pins

PADR is initialized to H'00 by a reset and in hardware standby mode. In software standby mode it retains its previous setting.

**Table 8.19 Port A Pin Functions (Modes 1, 2, 6, 7)**

**Pin Pin Functions and Selection Method**

PA<sub>7</sub>/TP<sub>7</sub>/TIOCB<sub>2</sub> Bit PWM2 in TMDR, bits IOB2 to IOB0 in TIOR2, bit NDER7 in NDERA, and bit PA<sub>7</sub>DDR select the pin function as follows.

16-bit timer channel 2 settings	(1) in table below	(2) in table below		
PA <sub>7</sub> DDR	—	0	1	1
NDER7	—	—	0	1
Pin function	TIOCB <sub>2</sub> output	PA <sub>7</sub> input	PA <sub>7</sub> output	TP <sub>7</sub> output
		TIOCB <sub>2</sub> input*		

Note: \* TIOCB<sub>2</sub> input when IOB2 = 1 and PWM2 = 0.

16-bit timer channel 2 settings	(2)	(1)		(2)
IOB2	0			1
IOB1	0	0	1	—
IOB0	0	1	—	—

**Table 8.19 Port A Pin Functions (Modes 1, 2, 6, 7) (cont)**
**Pin Pin Functions and Selection Method**

PA<sub>6</sub>/TP<sub>6</sub>/  
TIOCA<sub>2</sub> Bit PWM2 in TMDR, bits IOA2 to IOA0 in TIOR2, bit NDER6 in NDERA, and bit PA<sub>6</sub>DDR select the pin function as follows.

16-bit timer channel 2 settings	(1) in table below	(2) in table below		
PA <sub>6</sub> DDR	—	0	1	1
NDER6	—	—	0	1
Pin function	TIOCA <sub>2</sub> output	PA <sub>6</sub> input	PA <sub>6</sub> output	TP <sub>6</sub> output
		TIOCA <sub>2</sub> input*		

Note: \* TIOCA<sub>2</sub> input when IOA2 = 1.

16-bit timer channel 2 settings	(2)	(1)		(2)	(1)
PWM2	0			1	
IOA2	0		1		—
IOA1	0	0	1	—	—
IOA0	0	1	—	—	—

PA<sub>5</sub>/TP<sub>5</sub>/  
TIOCB<sub>1</sub> Bit PWM1 in TMDR, bits IOB2 to IOB0 in TIOR1, bit NDER5 in NDERA, and bit PA<sub>5</sub>DDR select the pin function as follows.

16-bit timer channel 1 settings	(1) in table below	(2) in table below		
PA <sub>5</sub> DDR	—	0	1	1
NDER5	—	—	0	1
Pin function	TIOCB <sub>1</sub> output	PA <sub>5</sub> input	PA <sub>5</sub> output	TP <sub>5</sub> output
		TIOCB <sub>1</sub> input*		

Note: \* TIOCB<sub>1</sub> input when IOB2 = 1 and PWM1 = 0.

16-bit timer channel 1 settings	(2)	(1)		(2)
IOB2	0			1
IOB1	0	0	1	—
IOB0	0	1	—	—

**Table 8.19 Port A Pin Functions (Modes 1, 2, 6, 7) (cont)**

**Pin Pin Functions and Selection Method**

PA<sub>4</sub>/TP<sub>4</sub>/  
TIOCA<sub>1</sub> Bit PWM1 in TMDR, bits IOA2 to IOA0 in TIOR1, bit NDER4 in NDERA, and bit PA<sub>4</sub>DDR select the pin function as follows.

16-bit timer channel 1 settings	(1) in table below	(2) in table below		
PA <sub>4</sub> DDR	—	0	1	1
NDER4	—	—	0	1
Pin function	TIOCA <sub>1</sub> output	PA <sub>4</sub> input	PA <sub>4</sub> output	TP <sub>4</sub> output
		TIOCA <sub>1</sub> input*		

Note: \* TIOCA<sub>1</sub> input when IOA2 = 1.

16-bit timer channel 1 settings	(2)	(1)		(2)	(1)
PWM1	0			1	
IOA2	0		1	—	
IOA1	0	0	1	—	—
IOA0	0	1	—	—	—

**Table 8.20 Port A Pin Functions (Modes 3, 4, 5)**

**Pin Pin Functions and Selection Method**

PA<sub>7</sub>/TP<sub>7</sub>/ Modes 3 and 4: Always used as A<sub>20</sub> output.

TIOCB <sub>2</sub> /A <sub>20</sub>	Pin function	A <sub>20</sub> output			
-------------------------------------	--------------	------------------------	--	--	--

Mode 5:

Bit PWM2 in TMDR, bits IOB2 to IOB0 in TIOR2, bit NDER7 in NDERA, bit A20E in BRCCR, and bit PA<sub>7</sub>DDR select the pin function as follows.

A20E	1				0
16-bit timer channel 2 settings	(1) in table below	(2) in table below			—
PA <sub>7</sub> DDR	—	0	1	1	—
NDER7	—	—	0	1	—
Pin function	TIOCB <sub>2</sub> output	PA <sub>7</sub> input	PA <sub>7</sub> output	TP <sub>7</sub> output	A <sub>20</sub> output
		TIOCB <sub>2</sub> input*			

Note: \* TIOCB<sub>2</sub> input when IOB2 = 1 and PWM2 = 0.

16-bit timer channel 2 settings	(2)	(1)			(2)
IOB2	0				1
IOB1	0	0	1	—	—
IOB0	0	1	—	—	—

PA<sub>6</sub>/TP<sub>6</sub>/ Bit PWM2 in TMDR, bits IOA2 to IOA0 in TIOR2, bit NDER6 in NDERA, bit A21E in BRCCR, and bit PA<sub>6</sub>DDR  
TIOCA<sub>2</sub>/A<sub>21</sub> select the pin function as follows.

A21E	1				0
16-bit timer channel 2 settings	(1) in table below	(2) in table below			—
PA <sub>6</sub> DDR	—	0	1	1	—
NDER6	—	—	0	1	—
Pin function	TIOCA <sub>2</sub> output	PA <sub>6</sub> input	PA <sub>6</sub> output	TP <sub>6</sub> output	A <sub>21</sub> output
		TIOCA <sub>2</sub> input*			

Note: \* TIOCA<sub>2</sub> input when IOA2 = 1.

16-bit timer channel 2 settings	(2)	(1)			(2)	(1)
PWM2	0				—	1
IOA2	0			1	—	—
IOA1	0	0	1	—	—	—
IOA0	0	1	—	—	—	—



**Table 8.20 Port A Pin Functions (Modes 3, 4, 5) (cont)**
**Pin Pin Functions and Selection Method**

PA<sub>5</sub>/TP<sub>5</sub>/  
TIOCB<sub>1</sub>/A<sub>22</sub> Bit PWM1 in TMDR, bits IOB2 to IOB0 in TIOR1, bit NDER5 in NDERA, bit A22E in BRCCR, and bit PA<sub>5</sub>DDR select the pin function as follows.

A22E	1				0
16-bit timer channel 1 settings	(1) in table below	(2) in table below			—
PA <sub>5</sub> DDR	—	0	1	1	—
NDER5	—	—	0	1	—
Pin function	TIOCB <sub>1</sub> output	PA <sub>5</sub> input	PA <sub>5</sub> output	TP <sub>5</sub> output	A <sub>22</sub> output
		TIOCB <sub>1</sub> input*			

Note: \* TIOCB<sub>1</sub> input when IOB2 = 1 and PWM1 = 0.

16-bit timer channel 1 settings	(2)	(1)		(2)
IOB2	0			1
IOB1	0	0	1	—
IOB0	0	1	—	—

PA<sub>4</sub>/TP<sub>4</sub>/  
TIOCA<sub>1</sub>/A<sub>23</sub> Bit PWM1 in TMDR, bits IOA2 to IOA0 in TIOR1, bit NDER4 in NDERA, bit A23E in BRCCR, and bit PA<sub>4</sub>DDR select the pin function as follows.

A23E	1				0
16-bit timer channel 1 settings	(1) in table below	(2) in table below			—
PA <sub>4</sub> DDR	—	0	1	1	—
NDER4	—	—	0	1	—
Pin function	TIOCA <sub>1</sub> output	PA <sub>4</sub> input	PA <sub>4</sub> output	TP <sub>4</sub> output	A <sub>23</sub> output
		TIOCA <sub>1</sub> input*			

Note: \* TIOCA<sub>1</sub> input when IOA2 = 1.

16-bit timer channel 1 settings	(2)	(1)	(2)	(1)
PWM1	0			1
IOA2	0		1	—
IOA1	0	0	1	—
IOA0	0	1	—	—

**Table 8.21 Port A Pin Functions (Modes 1 to 7)**

**Pin Pin Functions and Selection Method**

PA<sub>3</sub>/TP<sub>3</sub>/  
TIOCB<sub>0</sub>/  
TCLKD

Bit PWM0 in TMDR, bits IOB2 to IOB0 in TIOR0, bits TPSC2 to TPSC0 in TCR2 to TCR0 of the 16-bit timer, bits CKS2 to CKS0 in TCR3 of the 8-bit timer, bit NDER3 in NDERA, and bit PA<sub>3</sub>DDR select the pin function as follows.

16-bit timer channel 0 settings	(1) in table below	(2) in table below		
PA <sub>3</sub> DDR	—	0	1	1
NDER3	—	—	0	1
Pin function	TIOCB <sub>0</sub> output	PA <sub>3</sub> input	PA <sub>3</sub> output	TP <sub>3</sub> output
		TIOCB <sub>0</sub> input*1		
		TCLKD input*2		

- Notes:
1. TIOCB<sub>0</sub> input when IOB2 = 1 and PWM0 = 0.
  2. TCLKD input when TPSC2 = TPSC1 = TPSC0 = 1 in any of TCR2 to TCR0, or bits CKS2 to CKS0 in TCR3 are as shown in (3) in the table below.

16-bit timer channel 0 settings	(2)	(1)		(2)
IOB2	0			1
IOB1	0	0	1	—
IOB0	0	1	—	—

8-bit timer channel 0 settings	(4)	(3)		
CKS2	0	1		
CKS1	—	0		1
CKS0	—	0	1	—

**Table 8.21 Port A Pin Functions (Modes 1 to 7) (cont)**
**Pin Pin Functions and Selection Method**

PA<sub>2</sub>/TP<sub>2</sub>/  
TIOCA<sub>0</sub>/  
TCLKC

Bit PWM0 in TMDR, bits IOA2 to IOA0 in TIOR0, bits TPSC2 to TPSC0 in TCR2 to TCR0 of the 16-bit timer, bits CKS2 to CKS0 in TCR1 of the 8-bit timer, bit NDER2 in NDERA, and bit PA<sub>2</sub>DDR select the pin function as follows.

16-bit timer channel 0 settings	(1) in table below	(2) in table below		
PA <sub>2</sub> DDR	—	0	1	1
NDER2	—	—	0	1
Pin function	TIOCA <sub>0</sub> output	PA <sub>2</sub> input	PA <sub>2</sub> output	TP <sub>2</sub> output
		TIOCA <sub>0</sub> input*1		
		TCLKC input*2		

- Notes:
1. TIOCA<sub>0</sub> input when IOA2 = 1.
  2. TCLKC input when TPSC2 = TPSC1 = 1 and TPSC0 = 0 in any of TCR2 to TCR0, or bits CKS2 to CKS0 in TCR1 are as shown in (3) in the table below.

16-bit timer channel 0 settings	(2)	(1)		(2)	(1)
PWM0	0				1
IOA2	0			1	—
IOA1	0	0	1	—	—
IOA0	0	1	—	—	—

8-bit timer channel 1 settings	(4)		(3)	
CKS2	0	1		
CKS1	—	0		1
CKS0	—	0	1	—

**Table 8.21 Port A Pin Functions (Modes 1 to 7) (cont)**
**Pin Pin Functions and Selection Method**

PA<sub>1</sub>/TP<sub>1</sub>/  
TCLKB/  
TEND<sub>1</sub> Bit MDF in TMDR, bits TPSC2 to TPSC0 in TCR2 to TCR0 of the 16-bit timer, bits CKS2 to CKS0 in TCR2 of the 8-bit timer, bit NDER1 in NDERA, and bit PA<sub>1</sub>DDR select the pin function as follows.

PA <sub>1</sub> DDR	0	1	1
NDER1	—	0	1
Pin function	PA <sub>1</sub> input	PA <sub>1</sub> output	TP <sub>1</sub> output
	TCLKB input* <sup>1</sup>		
	TEND <sub>1</sub> output* <sup>2</sup>		

- Notes:
1. TCLKB input when MDF = 1 in TMDR, or TPSC2 = 1, TPSC1 = 0, and TPSC0 = 1 in any of TCR2 to TCR0, or bits CKS2 to CKS0 in TCR2 are as shown in (1) in the table below.
  2. When an external request is specified as a DMAC activation source, TEND<sub>1</sub> output regardless of bits PA<sub>1</sub>DDR and NDER1.

8-bit timer channel 1 settings	(2)		(1)	
CKS2	0	1		
CKS1	—	0		1
CKS0	—	0	1	—

PA<sub>0</sub>/TP<sub>0</sub>/  
TCLKA/  
TEND<sub>0</sub> Bit MDF in TMDR, bits TPSC2 to TPSC0 in TCR2 to TCR0 of the 16-bit timer, bits CKS2 to CKS0 in TCR0 of the 8-bit timer, bit NDER0 in NDERA, and bit PA<sub>0</sub>DDR select the pin function as follows.

PA <sub>0</sub> DDR	0	1	
NDER0	—	0	1
Pin function	PA <sub>0</sub> input	PA <sub>0</sub> output	TP <sub>0</sub> output
	TCLKA input* <sup>1</sup>		
	TEND <sub>0</sub> output* <sup>2</sup>		

- Notes:
1. TCLKA input when MDF = 1 in TMDR, or TPSC2 = 1, TPSC1 = 0 and TPSC0 = 0 in any of TCR2 to TCR0, or bits CKS2 to CKS0 in TCR0 are as shown in (1) in the table below.
  2. When an external request is specified as a DMAC activation source, TEND<sub>0</sub> output regardless of bits PA<sub>0</sub>DDR and NDER0.

8-bit timer channel 0 settings	(2)		(1)	
CKS2	0	1		
CKS1	—	0		1
CKS0	—	0	1	—

## 8.12 Port B

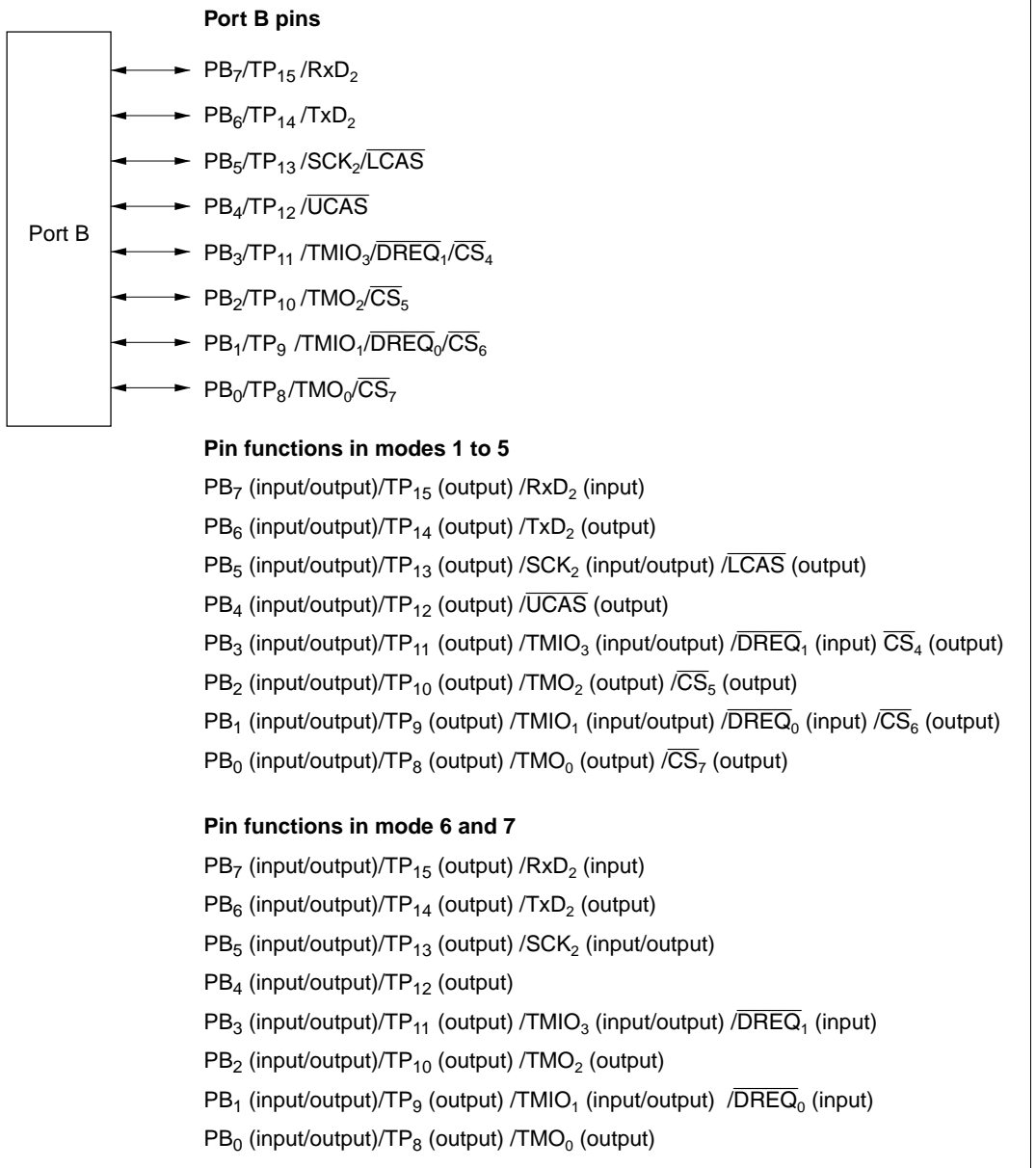
### 8.12.1 Overview

Port B is an 8-bit input/output port that is also used for output (TP<sub>15</sub> to TP<sub>8</sub>) from the programmable timing pattern controller (TPC), input/output (TMIO<sub>3</sub>, TMO<sub>2</sub>, TMIO<sub>1</sub>, TMO<sub>0</sub>) by the 8-bit timer,  $\overline{CS}_7$  to  $\overline{CS}_4$  output, input ( $\overline{DREQ}_1$ ,  $\overline{DREQ}_0$ ) to the DMA controller (DMAC), input and output (TxD<sub>2</sub>, RxD<sub>2</sub>, SCK<sub>2</sub>) by serial communication interface channel 2 (SCI2), and output ( $\overline{UCAS}$ ,  $\overline{LCAS}$ ) by the DRAM interface. See table 8.23 to 8.24 for the selection of pin functions. A reset or hardware standby transition leaves port B as an input port.

For output of  $\overline{CS}_7$  to  $\overline{CS}_4$  in modes 1 to 5, see section 6.3.4, Chip Select Signals. When DRAM is connected to areas 2, 3, 4, and 5, the  $\overline{CS}_4$  and  $\overline{CS}_5$  output pins become  $\overline{RAS}$  output pins for these areas. For details see 6.5, DRAM Interface. Pins not assigned to any of these functions are available for generic input/output. Figure 8.11 shows the pin configuration of port B.

When DRAM is connected to areas 2, 3, 4, and 5, the  $\overline{CS}_4$  and  $\overline{CS}_5$  output pins become  $\overline{RAS}$  output pins for these areas. For details see 6.5, DRAM Interface.

Pins in port B can drive one TTL load and a 30-pF capacitive load. They can also drive darlington transistor pair.



**Figure 8.11 Port B Pin Configuration**

## 8.12.2 Register Descriptions

Table 8.22 summarizes the registers of port B.

**Table 8.22 Port B Registers**

Address*	Name	Abbreviation	R/W	Initial Value
H'EE00A	Port B data direction register	PBDDR	W	H'00
H'FFFDA	Port B data register	PBDR	R/W	H'00

Note: \* Lower 20 bits of the address in advanced mode.

**Port B Data Direction Register (PBDDR):** PBDDR is an 8-bit write-only register that can select input or output for each pin in port B. When pins are used for TPC output, the corresponding PBDDR bits must also be set.

Bit	7	6	5	4	3	2	1	0
	PB <sub>7</sub> DDR	PB <sub>6</sub> DDR	PB <sub>5</sub> DDR	PB <sub>4</sub> DDR	PB <sub>3</sub> DDR	PB <sub>2</sub> DDR	PB <sub>1</sub> DDR	PB <sub>0</sub> DDR
Initial value	0	0	0	0	0	0	0	0
Read/Write	W	W	W	W	W	W	W	W

### Port B data direction 7 to 0

These bits select input or output for port B pins

The pin functions that can be selected for port B differ between modes 1 to 5, and modes 6 and 7. For the method of selecting the pin functions, see tables 8.23 and 8.24.

When port B functions as an input/output port, a pin in port B becomes an output port if the corresponding PBDDR bit is set to 1, and an input port if this bit is cleared to 0.

PBDDR is a write-only register. Its value cannot be read. All bits return 1 when read.

PBDDR is initialized to H'00 by a reset and in hardware standby mode. In software standby mode it retains its previous setting. Therefore, if a transition is made to software standby mode while port B is functioning as an input/output port and a PBDDR bit is set to 1, the corresponding pin maintains its output state.

**Port B Data Register (PBDR):** PBDR is an 8-bit readable/writable register that stores output data for pins port B. When port B functions as an output port, the value of this register is output. When a bit in PBDDR is set to 1, if port B is read the value of the corresponding PBDR bit is returned. When a bit in PBDDR is cleared to 0, if port B is read the corresponding pin logic level is read.

Bit	7	6	5	4	3	2	1	0
	PB <sub>7</sub>	PB <sub>6</sub>	PB <sub>5</sub>	PB <sub>4</sub>	PB <sub>3</sub>	PB <sub>2</sub>	PB <sub>1</sub>	PB <sub>0</sub>
Initial value	0	0	0	0	0	0	0	0
Read/Write	R/W	R/W	R/W	R/W	R/W	R/W	R/W	R/W

**Port B data 7 to 0**

These bits store data for port B pins

PBDR is initialized to H'00 by a reset and in hardware standby mode. In software standby mode it retains its previous setting.



**Table 8.23 Port B Pin Functions (Modes 1 to 5)**
**Pin Pin Functions and Selection Method**

$PB_7/TP_{15}/RxD_2$  Bit RE in SCR of SCI2, bit SMIF in SCMR, bit NDER15 in NDERB, and bit  $PB_7DDR$  select the pin function as follows.

SMIF	0				1
RE	0			1	—
$PB_7DDR$	0	1	1	—	—
NDER15	—	0	1	—	—
Pin function	$PB_7$ input	$PB_7$ output	$TP_{15}$ output	$RxD_2$ input	$RxD_2$ input

$PB_6/TP_{14}/TxD_2$  Bit TE in SCR of SCI2, bit SMIF in SCMR, bit NDER14 in NDERB, and bit  $PB_6DDR$  select the pin function as follows.

SMIF	0				1
TE	0			1	—
$PB_6DDR$	0	1	1	—	—
NDER14	—	0	1	—	—
Pin function	$PB_6$ input	$PB_6$ output	$TP_{14}$ output	$TxD_2$ output	$TxD_2$ output*

Note: \* Functions as the  $TxD_2$  output pin, but there are two states: one in which the pin is driven, and another in which the pin is at high-impedance.

$PB_5/TP_{13}/SCK_2/LCAS$  Bit  $C/\bar{A}$  in SMR of SCI2, bits CKE0 and CKE1 in SCR, bit NDER13 in NDERB, and bit  $PB_5DDR$  select the pin function as follows.

CKE1	0				1
$C/\bar{A}$	0			1	—
CKE0	0		1	—	—
$PB_5DDR$	0	1	1	—	—
NDER13	—	0	1	—	—
Pin function	$PB_5$ input	$PB_5$ output	$TP_{13}$ output	$SCK_2$ output	$SCK_2$ output
	$\overline{LCAS}$ output*				

Note: \*  $\overline{LCAS}$  output depending on bits DRAS2 to DRAS0 in DRCRA and bit CSEL in DRCRB, and regardless of bits  $C/\bar{A}$ , CKE0 and CKE1, NDER13, and  $PB_5DDR$ . For details, see section 6, Bus Controller.

$PB_4/TP_{12}/UCAS$  Bit NDER12 in NDERB and bit  $PB_4DDR$  select the pin function as follows.

$PB_4DDR$	0	1	1
NDER12	—	0	1
Pin function	$PB_4$ input	$PB_4$ output	$TP_{12}$ output
	$\overline{UCAS}$ output*		

Note: \*  $\overline{UCAS}$  output depending on bits DRAS2 to DRAS0 in DRCRA and bit CSEL in DRCRB, and regardless of bits NDER12 and  $PB_4DDR$ . For details, see section 6, Bus Controller.

**Table 8.23 Port B Pin Functions (Modes 1 to 5) (cont)**
**Pin Pin Functions and Selection Method**

$PB_2/TP_{11}/TMIO_3/\overline{DREQ}_1/\overline{CS}_4$  The DRAM interface settings by bits DRAS2 to DRAS0 in DRCRA, bits OIS3/2 and OS1/0 in TCSR3, bits CCLR1 and CCLR0 in TCR3, bit CS4E in CSCR, bit NDER11 in NDERB, and bit  $PB_3DDR$  select the pin function as follows.

DRAM interface settings	(1) in table below					(2) in table below
OIS3/2 and OS1/0	All 0				Not all 0	—
CS4E	0			1	—	—
$PB_3DDR$	0	1	1	—	—	—
NDER11	—	0	1	—	—	—
Pin function	$PB_3$ input	$PB_3$ output	$TP_{11}$ output	$\overline{CS}_4$ output	$TMIO_3$ output	$\overline{CS}_4$ output* <sup>3</sup>
	$TMIO_3$ input* <sup>1</sup>					
	$\overline{DREQ}_1$ input* <sup>2</sup>					

- Notes:
1.  $TMIO_3$  input when CCLR1 = CCLR0 = 1.
  2. When an external request is specified as a DMAC activation source,  $\overline{DREQ}_1$  input regardless of bits OIS3 and OIS2, OS1 and OS0, CCLR1 and CCLR0, CS4E, NDER11, and  $PB_3DDR$ .
  3.  $\overline{CS}_4$  is output as  $\overline{RAS}_4$ .

DRAM interface settings	(1)				(2)				(1)
DRAS2	0				1				
DRAS1	0		1		0		1		
DRAS0	0	1	0	1	0	1	0	1	

$PB_2/TP_{10}/TMIO_2/\overline{CS}_5$  The DRAM interface settings by bits DRAS2 to DRAS0 in DRCRA, bits OIS3/2 and OS1/0 in TCSR2, bit CS5E in CSCR, bit NDER10 in NDERB, and bit  $PB_2DDR$  select the pin function as follows.

DRAM interface settings	(1) in table below					(2) in table below
OIS3/2 and OS1/0	All 0				Not all 0	—
CS5E	0			1	—	—
$PB_2DDR$	0	1	1	—	—	—
NDER10	—	0	1	—	—	—
Pin function	$PB_2$ input	$PB_2$ output	$TP_{10}$ output	$\overline{CS}_5$ output	$TMIO_2$ output	$\overline{CS}_5$ output*

Note: \*  $\overline{CS}_5$  is output as  $\overline{RAS}_5$ .

DRAM interface settings	(1)				(2)	(1)
DRAS2	0				1	
DRAS1	0		1		1	
DRAS0	0	1	0	1	0	1

**Table 8.23 Port B Pin Functions (Modes 1 to 5) (cont)**
**Pin Pin Functions and Selection Method**

$PB_1/TP_9/$   
 $TMIO_1/$   
 $DREQ_0/\overline{CS}_6$

Bits OIS3/2 and OS1/0 in TCSR1, bits CCLR1 and CCLR0 in TCR1, bit CS6E in CSCR, bit NDER9 in NDERB, and bit PB<sub>1</sub>DDR select the pin function as follows.

OIS3/2 and OS1/0	All 0				Not all 0
CS6E	0			1	—
PB <sub>1</sub> DDR	0	1	1	—	—
NDER9	—	0	1	—	—
Pin function	PB <sub>1</sub> input	PB <sub>1</sub> output	TP <sub>9</sub> output	$\overline{CS}_6$ output	TMIO <sub>1</sub> output
	TMIO <sub>1</sub> input*1				
	$\overline{DREQ}_0$ input*2				

- Notes:
1. TMIO<sub>1</sub> input when CCLR1 = CCLR0 = 1.
  2. When an external request is specified as a DMAC activation source,  $\overline{DREQ}_0$  input regardless of bits OIS3/2 and OS1/0, bits CCLR1/0, bit CS6E, bit NDER9, and bit PB<sub>1</sub>DDR.

$PB_0/TP_8/$   
 $TMO_0/\overline{CS}_7$

Bits OIS3/2 and OS1/0 in TCSR0, bit CS7E in CSCR, bit NDER8 in NDERB, and bit PB<sub>0</sub>DDR select the pin function as follows.

OIS3/2 and OS1/0	All 0				Not all 0
CS7E	0			1	—
PB <sub>0</sub> DDR	0	1	1	—	—
NDER8	—	0	1	—	—
Pin function	PB <sub>0</sub> input	PB <sub>0</sub> output	TP <sub>8</sub> output	$\overline{CS}_7$ output	TMO <sub>0</sub> output

**Table 8.24 Port B Pin Functions (Modes 6 to 7)**
**Pin Pin Functions and Selection Method**

**PB<sub>7</sub>/TP<sub>15</sub>/RxD<sub>2</sub>** Bit RE in SCR of SCI2, bit SMIF in SCMR, bit NDER15 in NDERB, and bit PB<sub>7</sub>DDR select the pin function as follows.

SMIF	0				1
RE	0			1	—
PB <sub>7</sub> DDR	0	1	1	—	—
NDER15	—	0	1	—	—
Pin function	PB <sub>7</sub> input	PB <sub>7</sub> output	TP <sub>15</sub> output	RxD <sub>2</sub> input	RxD <sub>2</sub> input

**PB<sub>6</sub>/TP<sub>14</sub>/TxD<sub>2</sub>** Bit TE in SCR of SCI2, bit SMIF in SCMR, bit NDER14 in NDERB, and bit PB<sub>6</sub>DDR select the pin function as follows.

SMIF	0				1
TE	0			1	—
PB <sub>6</sub> DDR	0	1	1	—	—
NDER14	—	0	1	—	—
Pin function	PB <sub>6</sub> input	PB <sub>6</sub> output	TP <sub>14</sub> output	TxD <sub>2</sub> output	TxD <sub>2</sub> output*

Note: \* Functions as the TxD2 output pin, but there are two states: one in which the pin is driven, and another in which the pin is at high-impedance.

**PB<sub>5</sub>/TP<sub>13</sub>/SCK<sub>2</sub>** Bit C/ $\bar{A}$  in SMR of SCI2, bits CKE0 and CKE1 in SCR, bit NDER13 in NDERB, and bit PB<sub>5</sub>DDR select the pin function as follows.

CKE1	0				1
C/ $\bar{A}$	0			1	—
CKE0	0		1	—	—
PB <sub>5</sub> DDR	0	1	1	—	—
NDER13	—	0	1	—	—
Pin function	PB <sub>5</sub> input	PB <sub>5</sub> output	TP <sub>13</sub> output	SCK <sub>2</sub> output	SCK <sub>2</sub> input

**PB<sub>4</sub>/TP<sub>12</sub>** Bit NDER12 in NDERB and bit PB<sub>4</sub>DDR select the pin function as follows.

PB <sub>4</sub> DDR	0	1	1
NDER12	—	0	1
Pin function	PB <sub>4</sub> input	PB <sub>4</sub> output	TP <sub>12</sub> output

**Table 8.24 Port B Pin Functions (Modes 6 to 7) (cont)**

Pin	Pin Functions and Selection Method			
PB <sub>3</sub> /TP <sub>11</sub> / TMIO <sub>3</sub> / DREQ <sub>1</sub>	Bits OIS3/2 and OS1/0 in TCSR3, bits CCLR1 and CCLR0 in TCR3, bit NDER11 in NDERB, and bit PB <sub>3</sub> DDR select the pin function as follows.			
OIS3/2 and OS1/0	All 0			Not all 0
PB <sub>3</sub> DDR	0	1	1	—
NDER11	—	0	1	—
Pin function	PB <sub>3</sub> input	PB <sub>3</sub> output	TP <sub>11</sub> output	TMIO <sub>3</sub> output
	TMIO <sub>3</sub> input* <sup>1</sup>			
	DREQ <sub>1</sub> input* <sup>2</sup>			
Notes:	1. TMIO <sub>3</sub> input when CCLR1 = CCLR0 = 1. 2. When an external request is specified as a DMAC activation source, DREQ <sub>1</sub> input regardless of bits OIS3/2 and OS1/0, bit NDER11, and bit PB <sub>3</sub> DDR.			
PB <sub>2</sub> /TP <sub>10</sub> / TMO <sub>2</sub>	Bits OIS3/2 and OS1/0 in TCSR2, bit NDER10 in NDERB, and bit PB <sub>2</sub> DDR select the pin function as follows.			
OIS3/2 and OS1/0	All 0			Not all 0
PB <sub>2</sub> DDR	0	1	1	—
NDER10	—	0	1	—
Pin function	PB <sub>2</sub> input	PB <sub>2</sub> output	TP <sub>10</sub> output	TMO <sub>2</sub> output
	TMIO <sub>1</sub> input* <sup>1</sup>			
	DREQ <sub>0</sub> input* <sup>2</sup>			
Notes:	1. TMIO <sub>1</sub> input when CCLR1 = CCLR0 = 1. 2. When an external request is specified as a DMAC activation source, DREQ <sub>0</sub> input regardless of bits OIS3/2 and OS1/0, bit NDER9, and bit PB <sub>2</sub> DDR.			
PB <sub>1</sub> /TP <sub>9</sub> / TMIO <sub>1</sub> / DREQ <sub>0</sub>	Bits OIS3/2 and OS1/0 in TCSR1, bits CCLR1 and CCLR0 in TCR1, bit NDER9 in NDERB, and bit PB <sub>1</sub> DDR select the pin function as follows.			
OIS3/2 and OS1/0	All 0			Not all 0
PB <sub>1</sub> DDR	0	1	1	—
NDER9	—	0	1	—
Pin function	PB <sub>1</sub> input	PB <sub>1</sub> output	TP <sub>9</sub> output	TMIO <sub>1</sub> output
	TMIO <sub>1</sub> input* <sup>1</sup>			
	DREQ <sub>0</sub> input* <sup>2</sup>			
Notes:	1. TMIO <sub>1</sub> input when CCLR1 = CCLR0 = 1. 2. When an external request is specified as a DMAC activation source, DREQ <sub>0</sub> input regardless of bits OIS3/2 and OS1/0, bit NDER9, and bit PB <sub>1</sub> DDR.			
PB <sub>0</sub> /TP <sub>8</sub> / TMO <sub>0</sub>	Bits OIS3/2 and OS1/0 in TCSR0, bit NDER8 in NDERB, and bit PB <sub>0</sub> DDR select the pin function as follows.			
OIS3/2 and OS1/0	All 0			Not all 0
PB <sub>0</sub> DDR	0	1	1	—
NDER8	—	0	1	—
Pin function	PB <sub>0</sub> input	PB <sub>0</sub> output	TP <sub>8</sub> output	TMO <sub>0</sub> output
	TMIO <sub>1</sub> input* <sup>1</sup>			
	DREQ <sub>0</sub> input* <sup>2</sup>			
Notes:	1. TMIO <sub>1</sub> input when CCLR1 = CCLR0 = 1. 2. When an external request is specified as a DMAC activation source, DREQ <sub>0</sub> input regardless of bits OIS3/2 and OS1/0, bit NDER9, and bit PB <sub>1</sub> DDR.			



# Section 9 16-Bit Timer

## 9.1 Overview

The H8/3067 Series has built-in 16-bit timer module with three 16-bit counter channels.

### 9.1.1 Features

16-bit timer features are listed below.

- Capability to process up to 6 pulse outputs or 6 pulse inputs
- Six general registers (GRs, two per channel) with independently-assignable output compare or input capture functions
- Selection of eight counter clock sources for each channel:  
Internal clocks:  $\phi$ ,  $\phi/2$ ,  $\phi/4$ ,  $\phi/8$   
External clocks: TCLKA, TCLKB, TCLKC, TCLKD
- Five operating modes selectable in all channels:
  - Waveform output by compare match  
Selection of 0 output, 1 output, or toggle output (only 0 or 1 output in channel 2)
  - Input capture function  
Rising edge, falling edge, or both edges (selectable)
  - Counter clearing function  
Counters can be cleared by compare match or input capture
  - Synchronization  
Two or more timer counters (TCNTs) can be preset simultaneously, or cleared simultaneously by compare match or input capture. Counter synchronization enables synchronous register input and output.
  - PWM mode  
PWM output can be provided with an arbitrary duty cycle. With synchronization, up to three-phase PWM output is possible

- Phase counting mode selectable in channel 2  
Two-phase encoder output can be counted automatically.
- High-speed access via internal 16-bit bus  
The TCNTs and GRs can be accessed at high speed via a 16-bit bus.
- Any initial timer output value can be set
- Nine interrupt sources  
Each channel has two compare match/input capture interrupts and an overflow interrupt. All interrupts can be requested independently.
- Output triggering of programmable timing pattern controller (TPC)  
Compare match/input capture signals from channels 0 to 2 can be used as TPC output triggers.



Table 9.1 summarizes the 16-bit timer functions.

**Table 9.1 16-bit timer Functions**

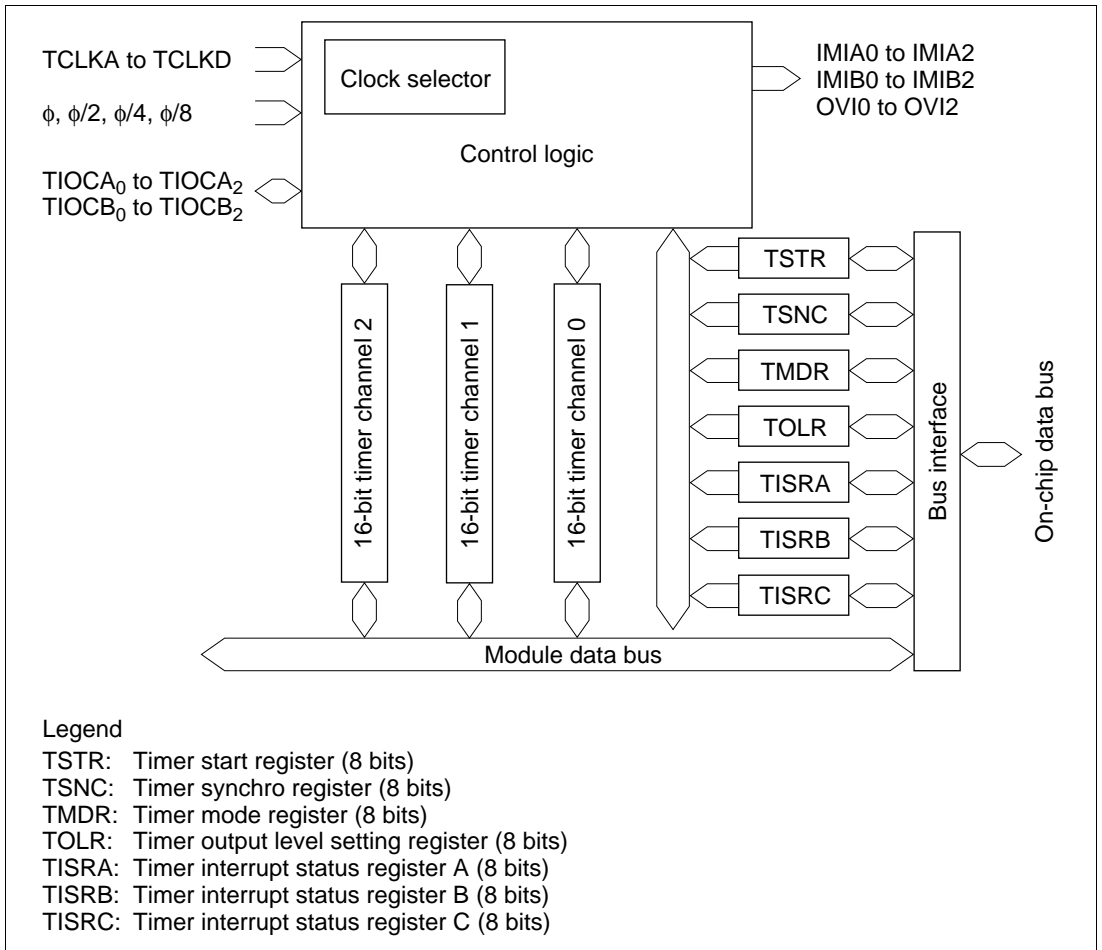
Item	Channel 0	Channel 1	Channel 2
Clock sources	Internal clocks: $\phi$ , $\phi/2$ , $\phi/4$ , $\phi/8$ External clocks: TCLKA, TCLKB, TCLKC, TCLKD, selectable independently		
General registers (output compare/input capture registers)	GRA0, GRB0	GRA1, GRB1	GRA2, GRB2
Input/output pins	TIOCA <sub>0</sub> , TIOCB <sub>0</sub>	TIOCA <sub>1</sub> , TIOCB <sub>1</sub>	TIOCA <sub>2</sub> , TIOCB <sub>2</sub>
Counter clearing function	GRA0/GRB0 compare match or input capture	GRA1/GRB1 compare match or input capture	GRA2/GRB2 compare match or input capture
Initial output value setting function	○	○	○
Compare match output	0	○	○
	1	○	○
	Toggle	○	—
Input capture function	○	○	○
Synchronization	○	○	○
PWM mode	○	○	○
Phase counting mode	—	—	○
Interrupt sources	Three sources <ul style="list-style-type: none"> <li>• Compare match/input capture A0</li> <li>• Compare match/input capture B0</li> <li>• Overflow</li> </ul>	Three sources <ul style="list-style-type: none"> <li>• Compare match/input capture A1</li> <li>• Compare match/input capture B1</li> <li>• Overflow</li> </ul>	Three sources <ul style="list-style-type: none"> <li>• Compare match/input capture A2</li> <li>• Compare match/input capture B2</li> <li>• Overflow</li> </ul>

**Legend**

- : Available
- : Not available

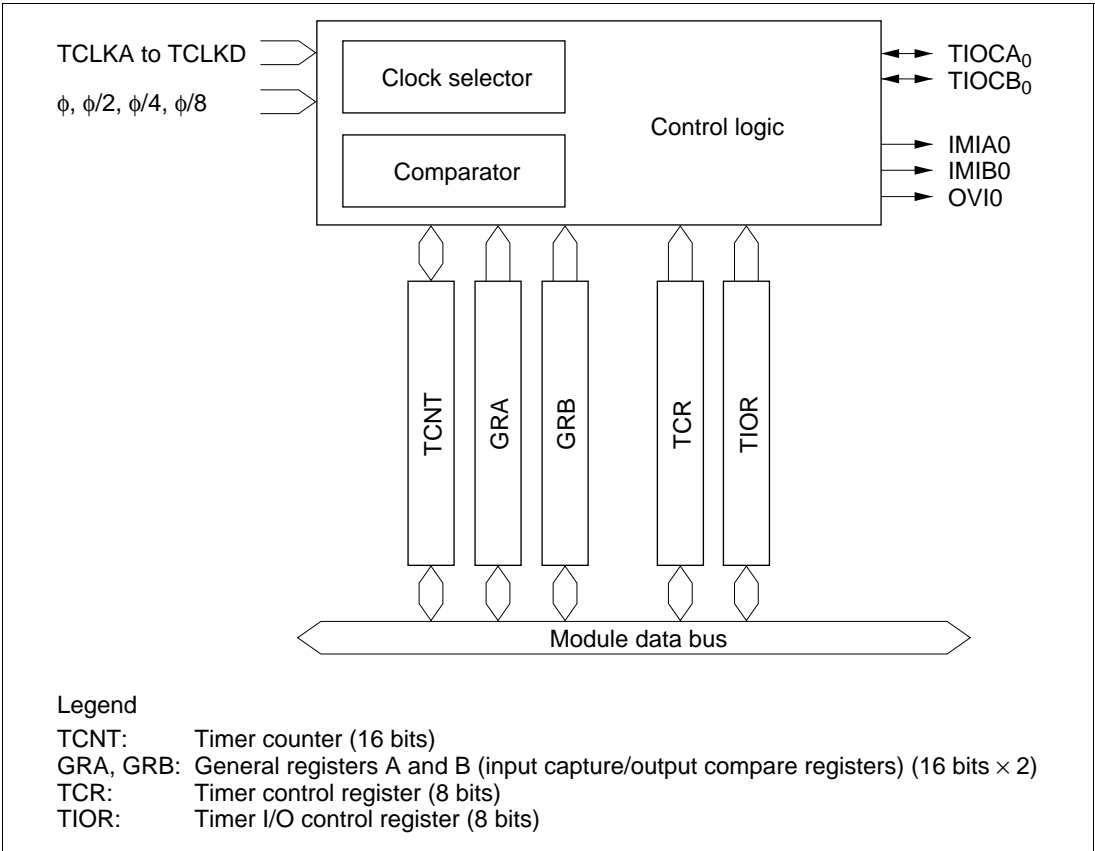
## 9.1.2 Block Diagrams

**16-bit timer Block Diagram (Overall):** Figure 9.1 is a block diagram of the 16-bit timer.



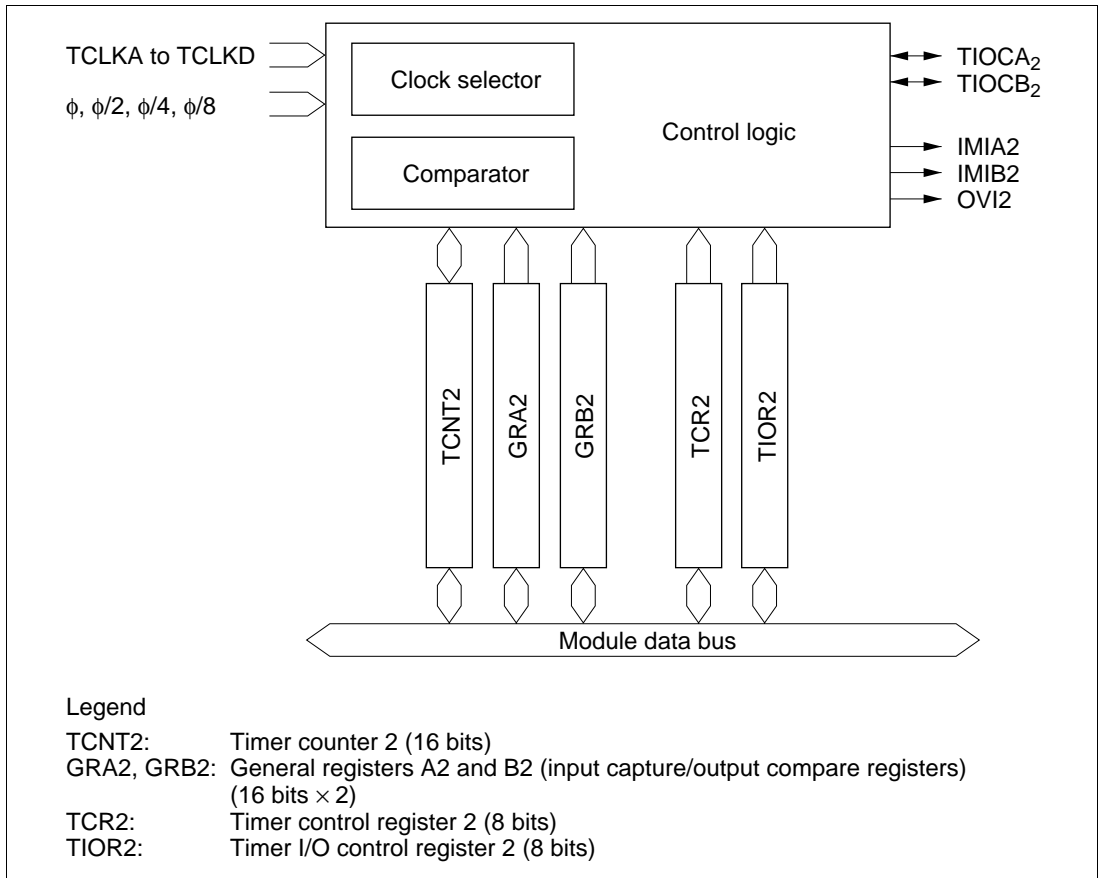
**Figure 9.1 16-bit timer Block Diagram (Overall)**

**Block Diagram of Channels 0 and 1:** 16-bit timer channels 0 and 1 are functionally identical. Both have the structure shown in figure 9.2.



**Figure 9.2 Block Diagram of Channels 0 and 1**

**Block Diagram of Channel 2:** Figure 9.3 is a block diagram of channel 2



**Figure 9.3 Block Diagram of Channel 2**

### 9.1.3 Input/Output Pins

Table 9.2 summarizes the 16-bit timer pins.

**Table 9.2 16-bit timer Pins**

Channel	Name	Abbreviation	Input/Output	Function
Common	Clock input A	TCLKA	Input	External clock A input pin (phase-A input pin in phase counting mode)
	Clock input B	TCLKB	Input	External clock B input pin (phase-B input pin in phase counting mode)
	Clock input C	TCLKC	Input	External clock C input pin
	Clock input D	TCLKD	Input	External clock D input pin
0	Input capture/output compare A0	TIOCA <sub>0</sub>	Input/output	GRA0 output compare or input capture pin PWM output pin in PWM mode
	Input capture/output compare B0	TIOCB <sub>0</sub>	Input/output	GRB0 output compare or input capture pin
1	Input capture/output compare A1	TIOCA <sub>1</sub>	Input/output	GRA1 output compare or input capture pin PWM output pin in PWM mode
	Input capture/output compare B1	TIOCB <sub>1</sub>	Input/output	GRB1 output compare or input capture pin
2	Input capture/output compare A2	TIOCA <sub>2</sub>	Input/output	GRA2 output compare or input capture pin PWM output pin in PWM mode
	Input capture/output compare B2	TIOCB <sub>2</sub>	Input/output	GRB2 output compare or input capture pin

## 9.1.4 Register Configuration

Table 9.3 summarizes the 16-bit timer registers.

**Table 9.3 16-bit timer Registers**

Channel	Address*1	Name	Abbreviation	R/W	Initial Value
Common	H'FFF60	Timer start register	TSTR	R/W	H'F8
	H'FFF61	Timer synchro register	TSNC	R/W	H'F8
	H'FFF62	Timer mode register	TMDR	R/W	H'98
	H'FFF63	Timer output level setting register	TOLR	W	H'C0
	H'FFF64	Timer interrupt status register A	TISRA	R/(W) *2	H'80
	H'FFF65	Timer interrupt status register B	TISRB	R/(W) *2	H'88
	H'FFF66	Timer interrupt status register C	TISRC	R/(W) *2	H'88
0	H'FFF68	Timer control register 0	TCR0	R/W	H'80
	H'FFF69	Timer I/O control register 0	TIOR0	R/W	H'88
	H'FFF6A	Timer counter 0H	TCNT0H	R/W	H'00
	H'FFF6B	Timer counter 0L	TCNT0L	R/W	H'00
	H'FFF6C	General register A0H	GRA0H	R/W	H'FF
	H'FFF6D	General register A0L	GRA0L	R/W	H'FF
	H'FFF6E	General register B0H	GRB0H	R/W	H'FF
	H'FFF6F	General register B0L	GRB0L	R/W	H'FF
1	H'FFF70	Timer control register 1	TCR1	R/W	H'80
	H'FFF71	Timer I/O control register 1	TIOR1	R/W	H'88
	H'FFF72	Timer counter 1H	TCNT1H	R/W	H'00
	H'FFF73	Timer counter 1L	TCNT1L	R/W	H'00
	H'FFF74	General register A1H	GRA1H	R/W	H'FF
	H'FFF75	General register A1L	GRA1L	R/W	H'FF
	H'FFF76	General register B1H	GRB1H	R/W	H'FF
	H'FFF77	General register B1L	GRB1L	R/W	H'FF

Notes: 1. The lower 20 bits of the address in advanced mode are indicated.

2. Only 0 can be written in bits 3 to 0, to clear the flags.

**Table 9.3 16-bit timer Registers (cont)**

<b>Channel</b>	<b>Address*1</b>	<b>Name</b>	<b>Abbreviation</b>	<b>R/W</b>	<b>Initial Value</b>
2	H'FFF78	Timer control register 2	TCR2	R/W	H'80
	H'FFF79	Timer I/O control register 2	TIOR2	R/W	H'88
	H'FFF7A	Timer counter 2H	TCNT2H	R/W	H'00
	H'FFF7B	Timer counter 2L	TCNT2L	R/W	H'00
	H'FFF7C	General register A2H	GRA2H	R/W	H'FF
	H'FFF7D	General register A2L	GRA2L	R/W	H'FF
	H'FFF7E	General register B2H	GRB2H	R/W	H'FF
	H'FFF7F	General register B2L	GRB2L	R/W	H'FF

Notes: 1. The lower 20 bits of the address in advanced mode are indicated.

## 9.2 Register Descriptions

### 9.2.1 Timer Start Register (TSTR)

TSTR is an 8-bit readable/writable register that starts and stops the timer counter (TCNT) in channels 0 to 2.

Bit	7	6	5	4	3	2	1	0
	—	—	—	—	—	STR2	STR1	STR0
Initial value	1	1	1	1	1	0	0	0
Read/Write	—	—	—	—	—	R/W	R/W	R/W

Reserved bits
Counter start 2 to 0  
These bits start and stop TCNT2 to TCNT0

TSTR is initialized to H'F8 by a reset and in standby mode.

**Bits 7 to 3—Reserved:** These bits cannot be modified and are always read as 1.

**Bit 2—Counter Start 2 (STR2):** Starts and stops timer counter 2 (TCNT2).

Bit 2 STR2	Description
0	TCNT2 is halted (Initial value)
1	TCNT2 is counting

**Bit 1—Counter Start 1 (STR1):** Starts and stops timer counter 1 (TCNT1).

Bit 1 STR1	Description
0	TCNT1 is halted (Initial value)
1	TCNT1 is counting

**Bit 0—Counter Start 0 (STR0):** Starts and stops timer counter 0 (TCNT0).

Bit 0 STR0	Description
0	TCNT0 is halted (Initial value)
1	TCNT0 is counting



## 9.2.2 Timer Synchro Register (TSNC)

TSNC is an 8-bit readable/writable register that selects whether channels 0 to 2 operate independently or synchronously. Channels are synchronized by setting the corresponding bits to 1.

Bit	7	6	5	4	3	2	1	0
	—	—	—	—	—	SYNC2	SYNC1	SYNC0
Initial value	1	1	1	1	1	0	0	0
Read/Write	—	—	—	—	—	R/W	R/W	R/W

**Reserved bits**
**Timer sync 2 to 0**  
These bits synchronize channels 2 to 0

TSNC is initialized to H'F8 by a reset and in standby mode.

**Bits 7 to 3—Reserved:** These bits cannot be modified and are always read as 1.

**Bit 2—Timer Sync 2 (SYNC2):** Selects whether channel 2 operates independently or synchronously.

### Bit 2

#### SYNC2 Description

0	Channel 2's timer counter (TCNT2) operates independently TCNT2 is preset and cleared independently of other channels	(Initial value)
1	Channel 2 operates synchronously TCNT2 can be synchronously preset and cleared	

**Bit 1—Timer Sync 1 (SYNC1):** Selects whether channel 1 operates independently or synchronously.

### Bit 1

#### SYNC1 Description

0	Channel 1's timer counter (TCNT1) operates independently TCNT1 is preset and cleared independently of other channels	(Initial value)
1	Channel 1 operates synchronously TCNT1 can be synchronously preset and cleared	

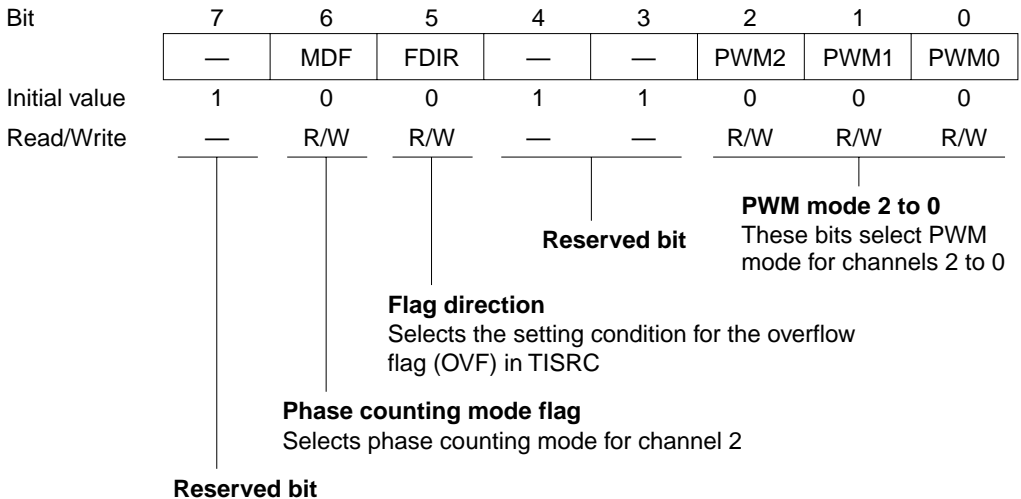
**Bit 0—Timer Sync 0 (SYNC0):** Selects whether channel 0 operates independently or synchronously.

**Bit 0**

SYNC0	Description	(Initial value)
0	Channel 0's timer counter (TCNT0) operates independently TCNT0 is preset and cleared independently of other channels	
1	Channel 0 operates synchronously TCNT0 can be synchronously preset and cleared	

**9.2.3 Timer Mode Register (TMDR)**

TMDR is an 8-bit readable/writable register that selects PWM mode for channels 0 to 2. It also selects phase counting mode and the overflow flag (OVF) setting conditions for channel 2.



TMDR is initialized to H'98 by a reset and in standby mode.









**Bit 7—Reserved:** This bit cannot be modified and is always read as 1.

**Bit 6—Phase Counting Mode Flag (MDF):** Selects whether channel 2 operates normally or in phase counting mode.

**Bit 6**

MDF	Description	(Initial value)
0	Channel 2 operates normally	
1	Channel 2 operates in phase counting mode	

When MDF is set to 1 to select phase counting mode, TCNT2 operates as an up/down-counter and pins TCLKA and TCLKB become counter clock input pins. TCNT2 counts both rising and falling edges of TCLKA and TCLKB, and counts up or down as follows.

Counting Direction	Down-Counting				Up-Counting			
TCLKA pin		High		Low	Low		High	
TCLKB pin	Low		High			High		Low

In phase counting mode channel 2 operates as above regardless of the external clock edges selected by bits CKEG1 and CKEG0 and the clock source selected by bits TPSC2 to TPSC0. Phase counting mode takes precedence over these settings.

The counter clearing condition selected by the CCLR1 and CCLR0 bits in TCR2 and the compare match/input capture settings and interrupt functions of TIOR2, TISRA, TISRB, TISRC remain effective in phase counting mode.

**Bit 5—Flag Direction (FDIR):** Designates the setting condition for the OVF flag in TISRC. The FDIR designation is valid in all modes in channel 2.

**Bit 5**

FDIR	Description
0	OVF is set to 1 in TISRC when TCNT2 overflows or underflows (Initial value)
1	OVF is set to 1 in TISRC when TCNT2 overflows

**Bits 4 and 3—Reserved:** These bits cannot be modified and are always read as 1.

**Bit 2—PWM Mode 2 (PWM2):** Selects whether channel 2 operates normally or in PWM mode.

**Bit 2**

PWM2	Description
0	Channel 2 operates normally (Initial value)
1	Channel 2 operates in PWM mode

When bit PWM2 is set to 1 to select PWM mode, pin TIOCA<sub>2</sub> becomes a PWM output pin. The output goes to 1 at compare match with GRA2, and to 0 at compare match with GRB2.

**Bit 1—PWM Mode 1 (PWM1):** Selects whether channel 1 operates normally or in PWM mode.

**Bit 1**

PWM1	Description	
0	Channel 1 operates normally	(Initial value)
1	Channel 1 operates in PWM mode	

When bit PWM1 is set to 1 to select PWM mode, pin TIOCA<sub>1</sub> becomes a PWM output pin. The output goes to 1 at compare match with GRA1, and to 0 at compare match with GRB1.

**Bit 0—PWM Mode 0 (PWM0):** Selects whether channel 0 operates normally or in PWM mode.

**Bit 0**

PWM0	Description	
0	Channel 0 operates normally	(Initial value)
1	Channel 0 operates in PWM mode	

When bit PWM0 is set to 1 to select PWM mode, pin TIOCA<sub>0</sub> becomes a PWM output pin. The output goes to 1 at compare match with GRA0, and to 0 at compare match with GRB0.

#### 9.2.4 Timer Interrupt Status Register A (TISRA)

TISRA is an 8-bit readable/writable register that indicates GRA compare match or input capture and enables or disables general register compare match and input capture interrupt requests.

Bit	7	6	5	4	3	2	1	0
	—	IMIEA2	IMIEA1	IMIEA0	—	IMFA2	IMFA1	IMFA0
Initial value	1	0	0	0	1	0	0	0
Read/Write	—	R/W	R/W	R/W	—	R/(W)*	R/(W)*	R/(W)*

**Reserved bit**  
**Input capture/compare match interrupt enable A2 to A0**  
 These bits enable or disable interrupts by the IMFA flags

**Input capture/compare match flags A2 to A0**  
 Status flags indicating GRA compare match or input capture

Note: \* Only 0 can be written, to clear the flag.

TISRA is initialized to H'88 by a reset and in standby mode.

**Bit 7—Reserved:** This bit cannot be modified and is always read as 1.

**Bit 6—Input Capture/Compare Match Interrupt Enable A2 (IMIEA2):** Enables or disables the interrupt requested by the IMFA2 flag when IMFA2 is set to 1.

**Bit 6**

**IMIEA2 Description**

0	IMIA2 interrupt requested by IMFA2 flag is disabled	(Initial value)
1	IMIA2 interrupt requested by IMFA2 flag is enabled	

**Bit 5—Input Capture/Compare Match Interrupt Enable A1 (IMIEA1):** Enables or disables the interrupt requested by the IMFA1 flag when IMFA1 is set to 1.

**Bit 5**

**IMIEA1 Description**

0	IMIA1 interrupt requested by IMFA1 flag is disabled	(Initial value)
1	IMIA1 interrupt requested by IMFA1 flag is enabled	

**Bit 4—Input Capture/Compare Match Interrupt Enable A0 (IMIEA0):** Enables or disables the interrupt requested by the IMFA0 flag when IMFA0 is set to 1.

**Bit 4**

**IMIEA0 Description**

0	IMIA0 interrupt requested by IMFA0 flag is disabled	(Initial value)
1	IMIA0 interrupt requested by IMFA0 flag is enabled	

**Bit 3—Reserved:** This bit cannot be modified and is always read as 1.

**Bit 2—Input Capture/Compare Match Flag A2 (IMFA2):** This status flag indicates GRA2 compare match or input capture events.

**Bit 2**

**IMFA2 Description**

0	[Clearing conditions] Read IMFA2 when IMFA2 =1, then write 0 in IMFA2. DMAC activated by IMIA2 interrupt.	(Initial value)
1	[Setting conditions] TCNT2 = GRA2 when GRA2 functions as an output compare register. TCNT2 value is transferred to GRA2 by an input capture signal when GRA2 functions as an input capture register.	

**Bit 1—Input Capture/Compare Match Flag A1 (IMFA1):** This status flag indicates GRA1 compare match or input capture events.

**Bit 1**

**IMFA1 Description**

0	[Clearing conditions] Read IMFA1 when IMFA1 =1, then write 0 in IMFA1. DMAC activated by IMIA1 interrupt.	(Initial value)
1	[Setting conditions] TCNT1 = GRA1 when GRA1 functions as an output compare register. TCNT1 value is transferred to GRA1 by an input capture signal when GRA1 functions as an input capture register.	

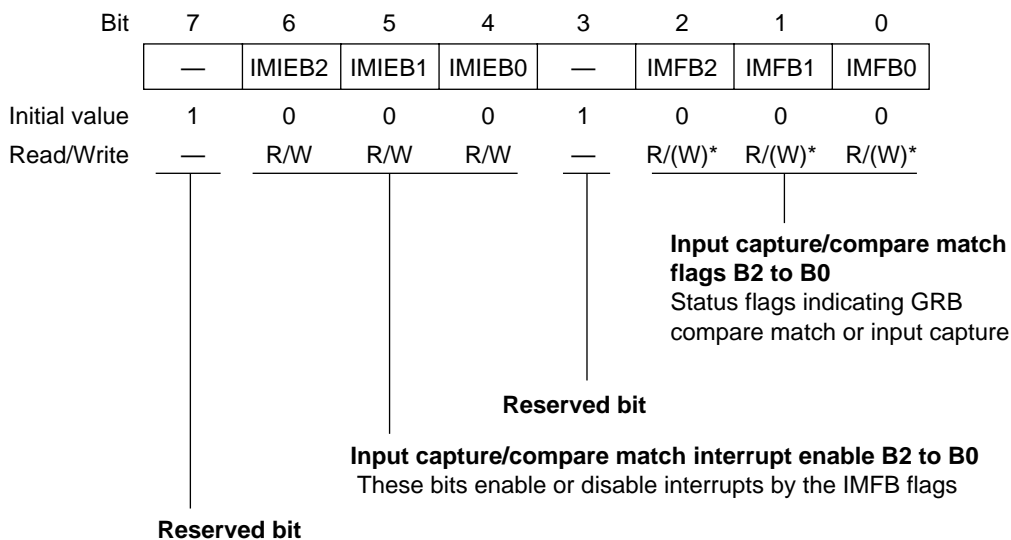
**Bit 0—Input Capture/Compare Match Flag A0 (IMFA0):** This status flag indicates GRA0 compare match or input capture events.

**Bit 0**

IMFA0	Description
0	[Clearing conditions] Read IMFA0 when IMFA0 =1, then write 0 in IMFA0. DMAC activated by IMIA0 interrupt. (Initial value)
1	[Setting conditions] TCNT0 = GRA0 when GRA0 functions as an output compare register. TCNT0 value is transferred to GRA0 by an input capture signal when GRA0 functions as an input capture register.

### 9.2.5 Timer Interrupt Status Register B (TISRB)

TISRB is an 8-bit readable/writable register that indicates GRB compare match or input capture and enables or disables general register compare match and input capture interrupt requests.



Note: \* Only 0 can be written, to clear the flag.

TISRB is initialized to H'88 by a reset and in standby mode.

**Bit 7—Reserved:** This bit cannot be modified and is always read as 1.

**Bit 6—Input Capture/Compare Match Interrupt Enable B2 (IMIEB2):** Enables or disables the interrupt requested by the IMFB2 flag when IMFB2 is set to 1.

**Bit 6**

**IMIEB2 Description**

0	IMIB2 interrupt requested by IMFB2 flag is disabled	(Initial value)
1	IMIB2 interrupt requested by IMFB2 flag is enabled	

**Bit 5—Input Capture/Compare Match Interrupt Enable B1 (IMIEB1):** Enables or disables the interrupt requested by the IMFB1 flag when IMFB1 is set to 1.

**Bit 5**

**IMIEB1 Description**

0	IMIB1 interrupt requested by IMFB1 flag is disabled	(Initial value)
1	IMIB1 interrupt requested by IMFB1 flag is enabled	

**Bit 4—Input Capture/Compare Match Interrupt Enable B0 (IMIEB0):** Enables or disables the interrupt requested by the IMFB0 flag when IMFB0 is set to 1.

**Bit 4**

**IMIEB0 Description**

0	IMIB0 interrupt requested by IMFB0 flag is disabled	(Initial value)
1	IMIB0 interrupt requested by IMFB0 flag is enabled	

**Bit 3—Reserved:** This bit cannot be modified and is always read as 1.

**Bit 2—Input Capture/Compare Match Flag B2 (IMFB2):** This status flag indicates GRB2 compare match or input capture events.

**Bit 2**

**IMFB2 Description**

0	[Clearing condition] Read IMFB2 when IMFB2 =1, then write 0 in IMFB2.	(Initial value)
1	[Setting conditions] TCNT2 = GRB2 when GRB2 functions as an output compare register. TCNT2 value is transferred to GRB2 by an input capture signal when GRB2 functions as an input capture register.	



**Bit 1—Input Capture/Compare Match Flag B1 (IMFB1):** This status flag indicates GRB1 compare match or input capture events.

**Bit 1**

<b>IMFB1</b>	<b>Description</b>	
0	[Clearing condition] Read IMFB1 when IMFB1 =1, then write 0 in IMFB1.	(Initial value)
1	[Setting conditions] TCNT1 = GRB1 when GRB1 functions as an output compare register. TCNT1 value is transferred to GRB1 by an input capture signal when GRB1 functions as an input capture register.	

**Bit 0—Input Capture/Compare Match Flag B0 (IMFB0):** This status flag indicates GRB0 compare match or input capture events.

**Bit 0**

<b>IMFB0</b>	<b>Description</b>	
0	[Clearing condition] Read IMFB0 when IMFB0 =1, then write 0 in IMFB0.	(Initial value)
1	[Setting conditions] TCNT0 = GRB0 when GRB0 functions as an output compare register. TCNT0 value is transferred to GRB0 by an input capture signal when GRB0 functions as an input capture register.	

## 9.2.6 Timer Interrupt Status Register C (TISRC)

TISRC is an 8-bit readable/writable register that indicates TCNT overflow or underflow and enables or disables overflow interrupt requests.

Bit	7	6	5	4	3	2	1	0
	—	OVIE2	OVIE1	OVIE0	—	OVF2	OVF1	OVF0
Initial value	1	0	0	0	1	0	0	0
Read/Write	—	R/W	R/W	R/W	—	R/(W)*	R/(W)*	R/(W)*

**Reserved bit**  
 These bits enable or disable interrupts by the OVF flags

**Overflow interrupt enable 2 to 0**  
 Status flags indicating overflow or underflow

**Reserved bit**

Note: \* Only 0 can be written, to clear the flag.

TISRC is initialized to H'88 by a reset and in standby mode.

**Bit 7—Reserved:** This bit cannot be modified and is always read as 1.

**Bit 6—Overflow Interrupt Enable 2 (OVIE2):** Enables or disables the interrupt requested by the OVF2 flag when OVF2 is set to 1.

### Bit 6

OVIE2	Description	
0	OVI2 interrupt requested by OVF2 flag is disabled	(Initial value)
1	OVI2 interrupt requested by OVF2 flag is enabled	

**Bit 5—Overflow Interrupt Enable 1 (OVIE1):** Enables or disables the interrupt requested by the OVF1 flag when OVF1 is set to 1.

### Bit 5

OVIE1	Description	
0	OVI1 interrupt requested by OVF1 flag is disabled	(Initial value)
1	OVI1 interrupt requested by OVF1 flag is enabled	

**Bit 4—Overflow Interrupt Enable 0 (OVIE0):** Enables or disables the interrupt requested by the OVF0 flag when OVF0 is set to 1.

**Bit 4**

<b>OVIE0</b>	<b>Description</b>	
0	OVI0 interrupt requested by OVF0 flag is disabled	(Initial value)
1	OVI0 interrupt requested by OVF0 flag is enabled	

**Bit 3—Reserved:** This bit cannot be modified and is always read as 1.

**Bit 2—Overflow Flag 2 (OVF2):** This status flag indicates TCNT2 overflow or underflow.

**Bit 2**

<b>OVF2</b>	<b>Description</b>	
0	[Clearing condition] Read OVF2 when OVF2 =1, then write 0 in OVF2.	(Initial value)
1	[Setting condition] TCNT2 overflowed from H'FFFF to H'0000, or underflowed from H'0000 to H'FFFF.	

Note: TCNT underflow occurs when TCNT operates as an up/down-counter. Underflow occurs only when channel 2 operates in phase counting mode (MDF = 1 in TMDR).

**Bit 1—Overflow Flag 1 (OVF1):** This status flag indicates TCNT1 overflow.

**Bit 1**

<b>OVF1</b>	<b>Description</b>	
0	[Clearing condition] Read OVF1 when OVF1 =1, then write 0 in OVF1.	(Initial value)
1	[Setting condition] TCNT1 overflowed from H'FFFF to H'0000.	

**Bit 0—Overflow Flag 0 (OVF0):** This status flag indicates TCNT0 overflow.

**Bit 0**

<b>OVF0</b>	<b>Description</b>	
0	[Clearing condition] Read OVF0 when OVF0 =1, then write 0 in OVF0.	(Initial value)
1	[Setting condition] TCNT0 overflowed from H'FFFF to H'0000.	

### 9.2.7 Timer Counters (TCNT)

TCNT is a 16-bit counter. The 16-bit timer has three TCNTs, one for each channel.

Channel	Abbreviation	Function
0	TCNT0	Up-counter
1	TCNT1	
2	TCNT2	Phase counting mode: up/down-counter Other modes: up-counter

Bit	15	14	13	12	11	10	9	8	7	6	5	4	3	2	1	0
	<input type="checkbox"/>	<input type="checkbox"/>	<input type="checkbox"/>	<input type="checkbox"/>	<input type="checkbox"/>	<input type="checkbox"/>	<input type="checkbox"/>	<input type="checkbox"/>	<input type="checkbox"/>	<input type="checkbox"/>	<input type="checkbox"/>	<input type="checkbox"/>	<input type="checkbox"/>	<input type="checkbox"/>	<input type="checkbox"/>	<input type="checkbox"/>
Initial value	0	0	0	0	0	0	0	0	0	0	0	0	0	0	0	0
Read/Write	R/W	R/W	R/W	R/W	R/W	R/W	R/W	R/W	R/W	R/W	R/W	R/W	R/W	R/W	R/W	R/W

Each TCNT is a 16-bit readable/writable register that counts pulse inputs from a clock source. The clock source is selected by bits TPSC2 to TPSC0 in TCR.

TCNT0 and TCNT1 are up-counters. TCNT2 is an up/down-counter in phase counting mode and an up-counter in other modes.

TCNT can be cleared to H'0000 by compare match with GRA or GRB or by input capture to GRA or GRB (counter clearing function).

When TCNT overflows (changes from H'FFFF to H'0000), the OVF flag is set to 1 in TISRC of the corresponding channel.

When TCNT underflows (changes from H'0000 to H'FFFF), the OVF flag is set to 1 in TISRC of the corresponding channel.

The TCNTs are linked to the CPU by an internal 16-bit bus and can be written or read by either word access or byte access.

Each TCNT is initialized to H'0000 by a reset and in standby mode.

## 9.2.8 General Registers (GRA, GRB)

The general registers are 16-bit registers. The 16-bit timer has 6 general registers, two in each channel.

Channel	Abbreviation	Function
0	GRA0, GRB0	Output compare/input capture register
1	GRA1, GRB1	
2	GRA2, GRB2	

Bit	15	14	13	12	11	10	9	8	7	6	5	4	3	2	1	0
Initial value	1	1	1	1	1	1	1	1	1	1	1	1	1	1	1	1
Read/Write	R/W	R/W	R/W	R/W	R/W	R/W	R/W	R/W	R/W	R/W	R/W	R/W	R/W	R/W	R/W	R/W

A general register is a 16-bit readable/writable register that can function as either an output compare register or an input capture register. The function is selected by settings in TIOR.

When a general register is used as an output compare register, its value is constantly compared with the TCNT value. When the two values match (compare match), the IMFA or IMFB flag is set to 1 in TISRA/TISRB. Compare match output can be selected in TIOR.

When a general register is used as an input capture register, rising edges, falling edges, or both edges of an external input capture signal are detected and the current TCNT value is stored in the general register. The corresponding IMFA or IMFB flag in TISRA/TISRB is set to 1 at the same time. The valid edge or edges of the input capture signal are selected in TIOR.

TIOR settings are ignored in PWM mode.

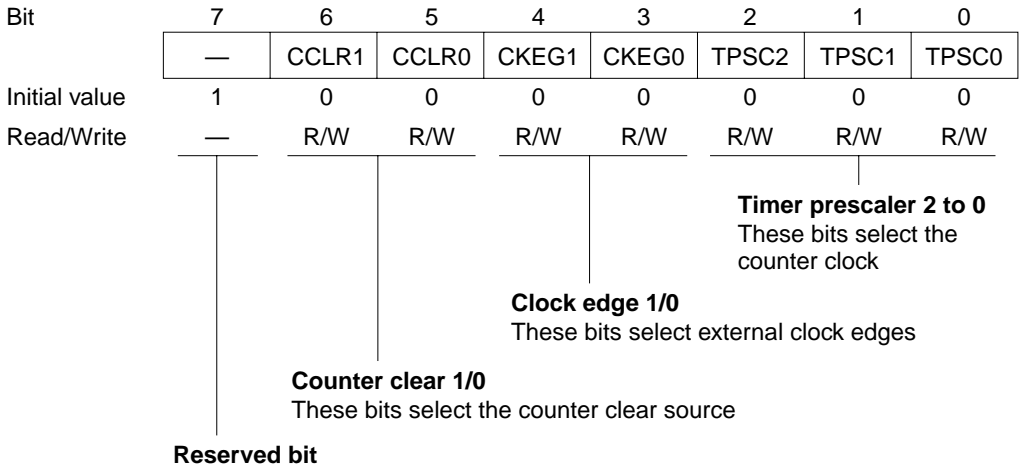
General registers are linked to the CPU by an internal 16-bit bus and can be written or read by either word access or byte access.

General registers are initialized to the output compare function (with no output signal) by a reset and in standby mode. The initial value is H'FFFF.

## 9.2.9 Timer Control Registers (TCR)

TCR is an 8-bit register. The 16-bit timer has three TCRs, one in each channel.

Channel	Abbreviation	Function
0	TCR0	CR controls the timer counter. The TCRs in all channels are functionally identical. When phase counting mode is selected in channel 2, the settings of bits CKEG1 and CKEG0 and TPSC2 to TPSC0 in TCR2 are ignored.
1	TCR1	
2	TCR2	



Each TCR is an 8-bit readable/writable register that selects the timer counter clock source, selects the edge or edges of external clock sources, and selects how the counter is cleared.

TCR is initialized to H'80 by a reset and in standby mode.

**Bit 7—Reserved:** This bit cannot be modified and is always read as 1.

**Bits 6 and 5—Counter Clear 1/0 (CCLR1, CCLR0):** These bits select how TCNT is cleared.

Bit 6 CCLR1	Bit 5 CCLR0	Description
0	0	TCNT is not cleared (Initial value)
	1	TCNT is cleared by GRA compare match or input capture* <sup>1</sup>
1	0	TCNT is cleared by GRB compare match or input capture* <sup>1</sup>
	1	Synchronous clear: TCNT is cleared in synchronization with other synchronized timers* <sup>2</sup>

- Notes:
1. TCNT is cleared by compare match when the general register functions as an output compare register, and by input capture when the general register functions as an input capture register.
  2. Selected in TSNC.

**Bits 4 and 3—Clock Edge 1/0 (CKEG1, CKEG0):** These bits select external clock input edges when an external clock source is used.

Bit 4 CKEG1	Bit 3 CKEG0	Description
0	0	Count rising edges (Initial value)
	1	Count falling edges
1	—	Count both edges

When channel 2 is set to phase counting mode, bits CKEG1 and CKEG0 in TCR2 are ignored. Phase counting takes precedence.

**Bits 2 to 0—Timer Prescaler 2 to 0 (TPSC2 to TPSC0):** These bits select the counter clock source.

Bit 2 TPSC2	Bit 1 TPSC1	Bit 0 TPSC0	Function
0	0	0	Internal clock: $\phi$ (Initial value)
		1	Internal clock: $\phi/2$
	1	0	Internal clock: $\phi/4$
		1	Internal clock: $\phi/8$
1	0	0	External clock A: TCLKA input
		1	External clock B: TCLKB input
	1	0	External clock C: TCLKC input
		1	External clock D: TCLKD input

When bit TPSC2 is cleared to 0 an internal clock source is selected, and the timer counts only falling edges. When bit TPSC2 is set to 1 an external clock source is selected, and the timer counts the edge or edges selected by bits CKEG1 and CKEG0.

When channel 2 is set to phase counting mode (MDF = 1 in TMDR), the settings of bits TPSC2 to TPSC0 in TCR2 are ignored. Phase counting takes precedence.

### 9.2.10 Timer I/O Control Register (TIOR)

TIOR is an 8-bit register. The 16-bit timer has three TIORs, one in each channel.

Channel	Abbreviation	Function
0	TIOR0	TIOR controls the general registers. Some functions differ in PWM mode.
1	TIOR1	
2	TIOR2	



Bit	7	6	5	4	3	2	1	0
	—	IOB2	IOB1	IOB0	—	IOA2	IOA1	IOA0
Initial value	1	0	0	0	1	0	0	0
Read/Write	—	R/W	R/W	R/W	—	R/W	R/W	R/W

**I/O control B2 to B0**  
 These bits select GRB functions

**I/O control A2 to A0**  
 These bits select GRA functions

**Reserved bit**

**Reserved bit**

Each TIOR is an 8-bit readable/writable register that selects the output compare or input capture function for GRA and GRB, and specifies the functions of the TIORA and TIORC pins. If the output compare function is selected, TIOR also selects the type of output. If input capture is selected, TIOR also selects the edge or edges of the input capture signal.

TIOR is initialized to H'88 by a reset and in standby mode.

**Bit 7—Reserved:** This bit cannot be modified and is always read as 1.

**Bits 6 to 4—I/O Control B2 to B0 (IOB2 to IOB0):** These bits select the GRB function.

Bit 6 IOB2	Bit 5 IOB1	Bit 4 IOB0	Function	
0	0	0	GRB is an output compare register	No output at compare match (Initial value)
		1		0 output at GRB compare match* <sup>1</sup>
	1	0	1 output at GRB compare match* <sup>1</sup>	
		1	Output toggles at GRB compare match (1 output in channel 2)* <sup>1</sup> , * <sup>2</sup>	
1	0	0	GRB is an input compare register	GRB captures rising edge of input
		1		GRB captures falling edge of input
	1	0	GRB captures both edges of input	
		1		

- Notes: 1. After a reset, the output conforms to the TOLR setting until the first compare match.  
 2. Channel 2 output cannot be toggled by compare match. This setting selects 1 output instead.

**Bit 3—Reserved:** This bit cannot be modified and is always read as 1.

**Bits 2 to 0—I/O Control A2 to A0 (IOA2 to IOA0):** These bits select the GRA function.

Bit 2 IOA2	Bit 1 IOA1	Bit 0 IOA0	Function
0	0	0	GRA is an output compare register
		1	No output at compare match (Initial value)
	1	0	0 output at GRA compare match* <sup>1</sup>
		1	1 output at GRA compare match* <sup>1</sup>
1	0	0	GRA is an input compare register
		1	GRA captures rising edge of input
		1	GRA captures falling edge of input
	1	0	Output toggles at GRA compare match (1 output in channel 2)* <sup>1</sup> , * <sup>2</sup>
		0	GRA captures both edges of input
		1	

- Notes: 1. After a reset, the output conforms to the TOLR setting until the first compare match.  
 2. Channel 2 output cannot be toggled by compare match. This setting selects 1 output instead.

### 9.2.11 Timer Output Level Setting Register C (TOLR)

TOLR is an 8-bit write-only register that selects the timer output level for channels 0 to 2.

Bit	7	6	5	4	3	2	1	0
	—	—	TOB2	TOA2	TOB1	TOA1	TOB0	TOA0
Initial value	1	1	0	0	0	0	0	0
Read/Write	—	—	W	W	W	W	W	W

Reserved bits

**Output level setting A2 to A0, B2 to B0**  
 These bits set the levels of the timer outputs (TIOCA<sub>2</sub> to TIOCA<sub>0</sub>, and TIOCB<sub>2</sub> to TIOCB<sub>0</sub>)

A TOLR setting can only be made when the corresponding bit in TSTR is 0.

TOLR is a write-only register; if read, a value of 1 will be returned.

TOLR is initialized to H'00 by a reset and in standby mode.

**Bits 7 and 6—Reserved:** These bits cannot be modified.

**Bit 5—Output Level Setting B2 (TOB2):** Sets the value of timer output TIOCB<sub>2</sub>.

**Bit 5**

<b>TOB2</b>	<b>Description</b>
0	TIOCB <sub>2</sub> is 0 (Initial value)
1	TIOCB <sub>2</sub> is 1

**Bit 4—Output Level Setting A2 (TOA2):** Sets the value of timer output TIOCA<sub>2</sub>.

**Bit 4**

<b>TOA2</b>	<b>Description</b>
0	TIOCA <sub>2</sub> is 0 (Initial value)
1	TIOCA <sub>2</sub> is 1

**Bit 3—Output Level Setting B1 (TOB1):** Sets the value of timer output TIOCB<sub>1</sub>.

**Bit 3**

<b>TOB1</b>	<b>Description</b>
0	TIOCB <sub>1</sub> is 0 (Initial value)
1	TIOCB <sub>1</sub> is 1

**Bit 2—Output Level Setting A1 (TOA1):** Sets the value of timer output TIOCA<sub>1</sub>.

**Bit 2**

<b>TOA1</b>	<b>Description</b>
0	TIOCA <sub>1</sub> is 0 (Initial value)
1	TIOCA <sub>1</sub> is 1

**Bit 1—Output Level Setting B0 (TOB0):** Sets the value of timer output TIOCB<sub>0</sub>.

**Bit 0**

<b>TOB0</b>	<b>Description</b>
0	TIOCB <sub>0</sub> is 0 (Initial value)
1	TIOCB <sub>0</sub> is 1

**Bit 0—Output Level Setting A0 (TOA0):** Sets the value of timer output TIOCA<sub>0</sub>.

**Bit 0**

**TOA0**

**Description**

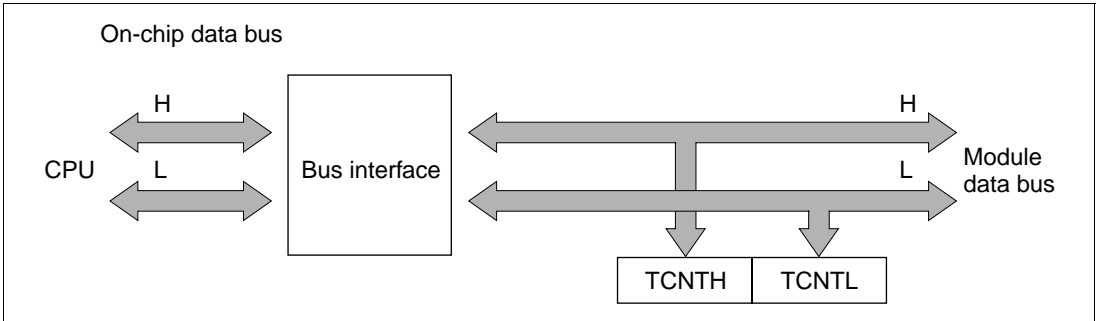
TOA0	Description
0	TIOCA <sub>0</sub> is 0 (Initial value)
1	TIOCA <sub>0</sub> is 1

## 9.3 CPU Interface

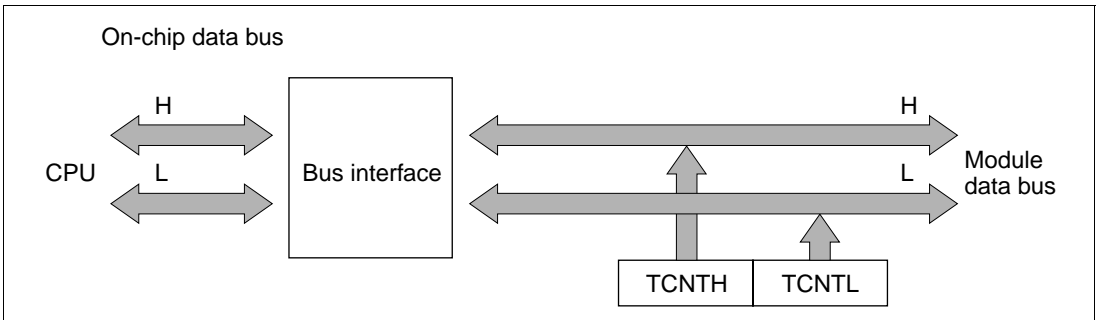
### 9.3.1 16-Bit Accessible Registers

The timer counters (TCNTs), general registers A and B (GRAs and GRBs) are 16-bit registers, and are linked to the CPU by an internal 16-bit data bus. These registers can be written or read a word at a time, or a byte at a time.

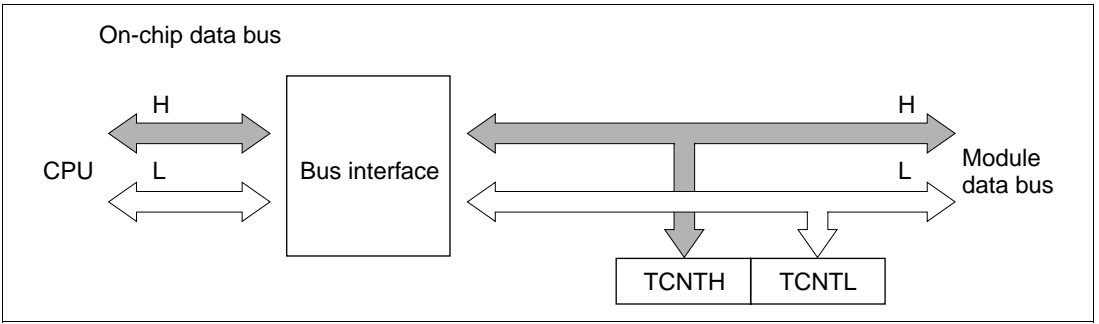
Figures 9.4 and 9.5 show examples of word read/write access to a timer counter (TCNT). Figures 9.6, 9.7, 9.8, and 9.9 show examples of byte read/write access to TCNTH and TCNTL.



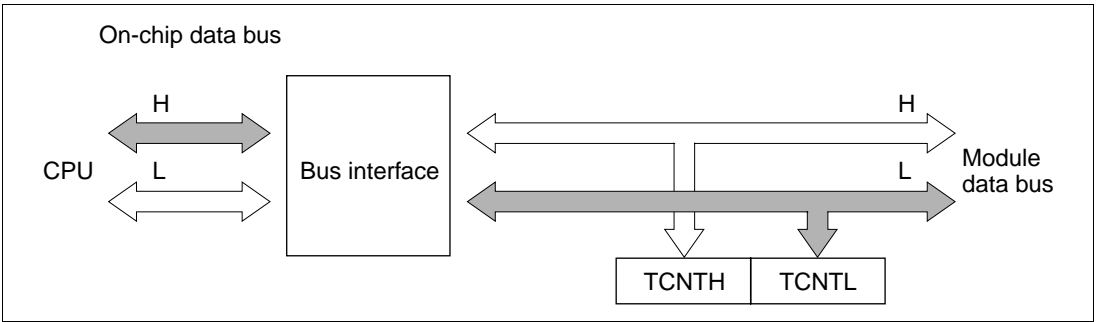
**Figure 9.4 Access to Timer Counter (CPU Writes to TCNT, Word)**



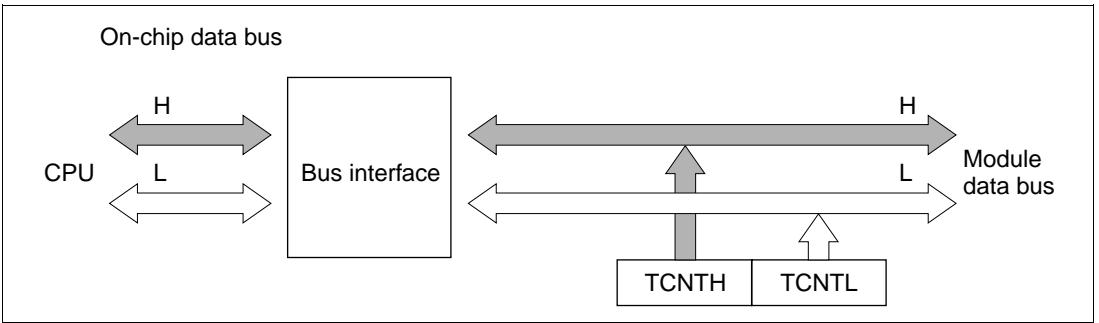
**Figure 9.5 Access to Timer Counter (CPU Reads TCNT, Word)**



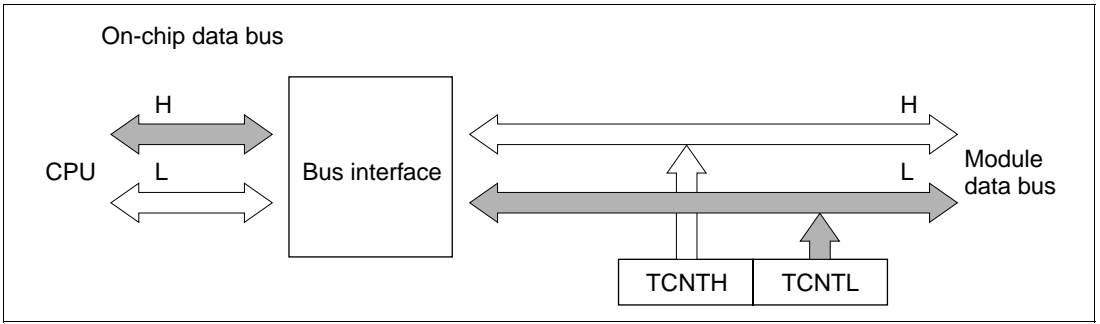
**Figure 9.6 Access to Timer Counter (CPU Writes to TCNT, Upper Byte)**



**Figure 9.7 Access to Timer Counter (CPU Writes to TCNT, Lower Byte)**



**Figure 9.8 Access to Timer Counter (CPU Reads TCNT, Upper Byte)**



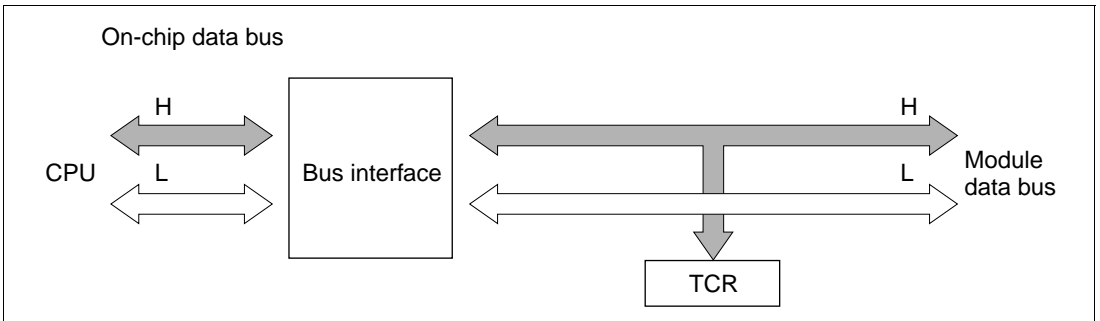
**Figure 9.9 Access to Timer Counter (CPU Reads TCNT, Lower Byte)**

### 9.3.2 8-Bit Accessible Registers

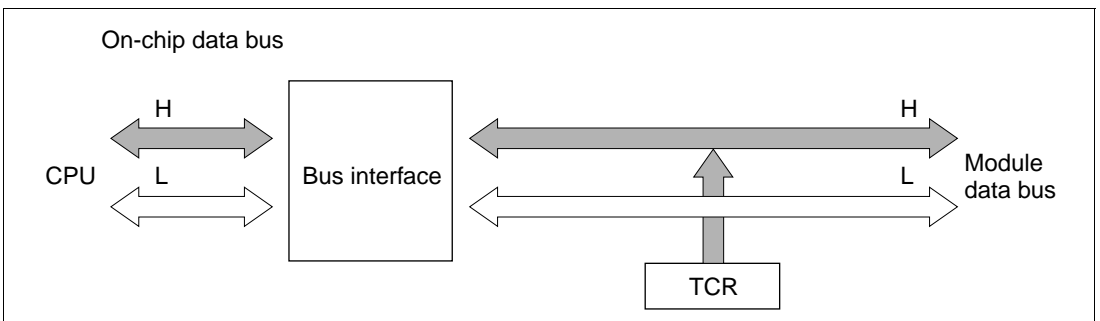
The registers other than the timer counters, general registers, and buffer registers are 8-bit registers. These registers are linked to the CPU by an internal 8-bit data bus.

Figures 9.10 and 9.11 show examples of byte read and write access to a TCR.

If a word-size data transfer instruction is executed, two byte transfers are performed.



**Figure 9.10 TCR Access (CPU Writes to TCR)**



**Figure 9.11 TCR Access (CPU Reads TCR)**

## 9.4 Operation

### 9.4.1 Overview

A summary of operations in the various modes is given below.

**Normal Operation:** Each channel has a timer counter and general registers. The timer counter counts up, and can operate as a free-running counter, periodic counter, or external event counter. General registers A and B can be used for input capture or output compare.

**Synchronous Operation:** The timer counters in designated channels are preset synchronously. Data written to the timer counter in any one of these channels is simultaneously written to the timer counters in the other channels as well. The timer counters can also be cleared synchronously if so designated by the CCLR1 and CCLR0 bits in the TCRs.

**PWM Mode:** A PWM waveform is output from the TIOCA pin. The output goes to 1 at compare match A and to 0 at compare match B. The duty cycle can be varied from 0% to 100% depending on the settings of GRA and GRB. When a channel is set to PWM mode, its GRA and GRB automatically become output compare registers.

**Phase Counting Mode:** The phase relationship between two clock signals input at TCLKA and TCLKB is detected and TCNT2 counts up or down accordingly. When phase counting mode is selected TCLKA and TCLKB become clock input pins and TCNT2 operates as an up/down-counter.

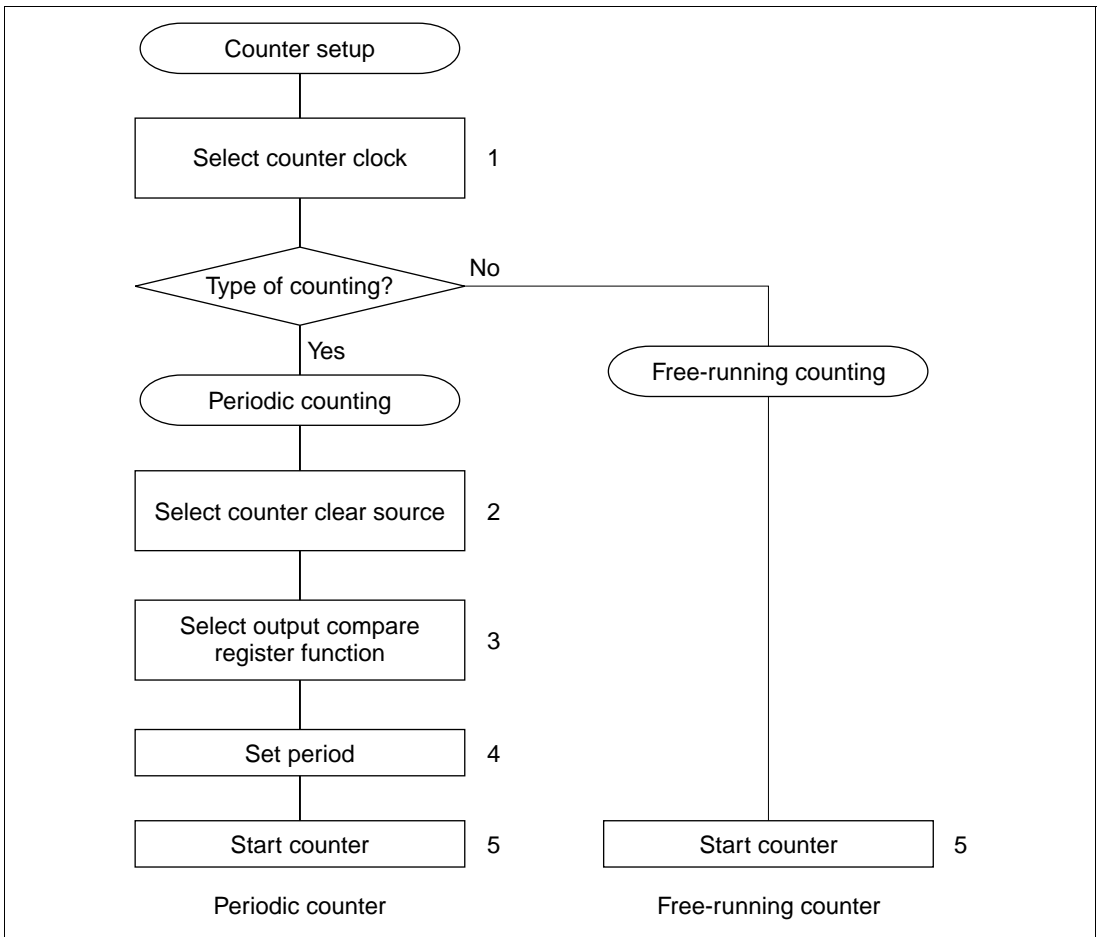
### 9.4.2 Basic Functions

**Counter Operation:** When one of bits STR0 to STR2 is set to 1 in the timer start register (TSTR), the timer counter (TCNT) in the corresponding channel starts counting. The counting can be free-running or periodic.

- Sample setup procedure for counter

Figure 9.12 shows a sample procedure for setting up a counter.



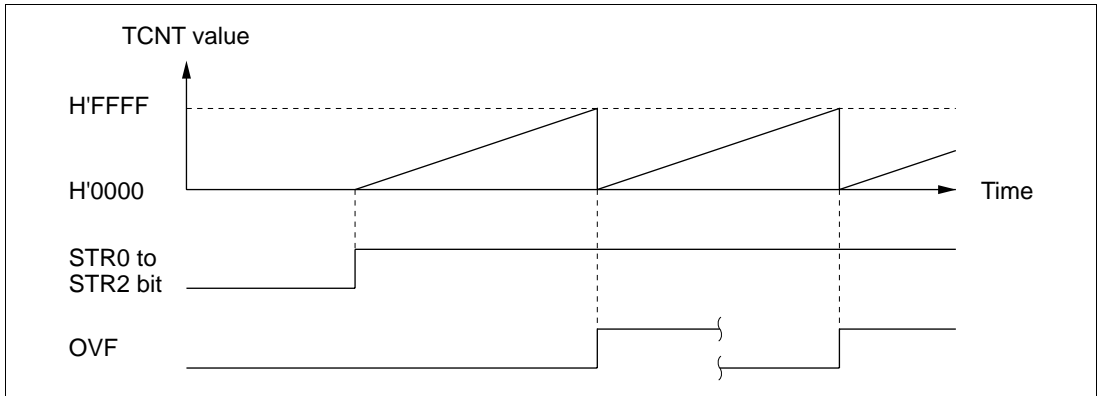


**Figure 9.12 Counter Setup Procedure (Example)**

1. Set bits TPSC2 to TPSC0 in TCR to select the counter clock source. If an external clock source is selected, set bits CKEG1 and CKEG0 in TCR to select the desired edge(s) of the external clock signal.
2. For periodic counting, set CCLR1 and CCLR0 in TCR to have TCNT cleared at GRA compare match or GRB compare match.
3. Set TIOR to select the output compare function of GRA or GRB, whichever was selected in step 2.
4. Write the count period in GRA or GRB, whichever was selected in step 2.
5. Set the STR bit to 1 in TSTR to start the timer counter.

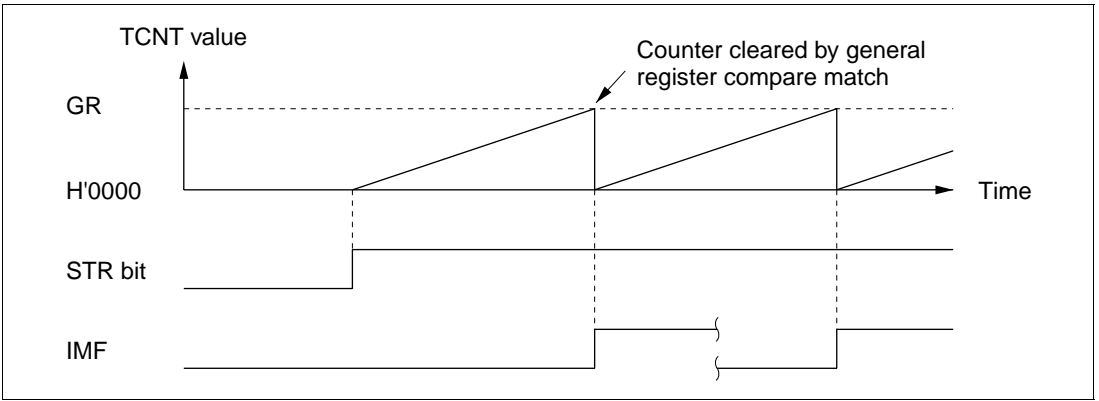
- Free-running and periodic counter operation

A reset leaves the counters (TCNTs) in 16-bit timer channels 0 to 2 all set as free-running counters. A free-running counter starts counting up when the corresponding bit in TSTR is set to 1. When the count overflows from H'FFFF to H'0000, the OVF flag is set to 1 in TISRC. After the overflow, the counter continues counting up from H'0000. Figure 9.13 illustrates free-running counting.



**Figure 9.13 Free-Running Counter Operation**

When a channel is set to have its counter cleared by compare match, in that channel TCNT operates as a periodic counter. Select the output compare function of GRA or GRB, set bit CCLR1 or CCLR0 in TCR to have the counter cleared by compare match, and set the count period in GRA or GRB. After these settings, the counter starts counting up as a periodic counter when the corresponding bit is set to 1 in TSTR. When the count matches GRA or GRB, the IMFA or IMFB flag is set to 1 in TISRA/TISRB and the counter is cleared to H'0000. If the corresponding IMIEA or IMIEB bit is set to 1 in TISRA/TISRB, a CPU interrupt is requested at this time. After the compare match, TCNT continues counting up from H'0000. Figure 9.14 illustrates periodic counting.



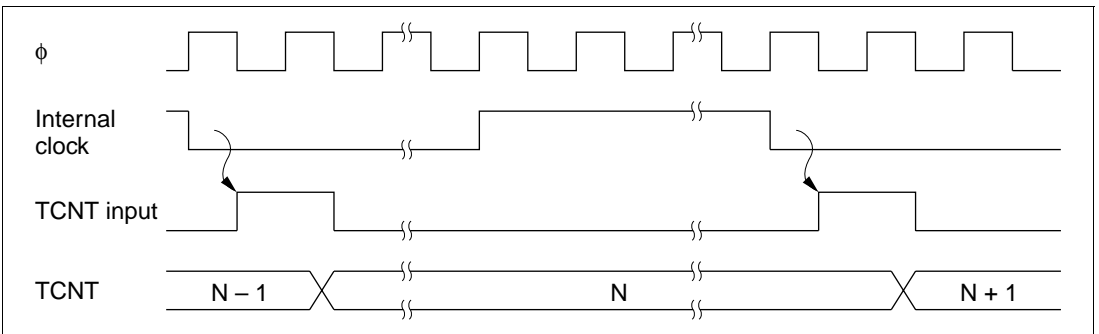
**Figure 9.14 Periodic Counter Operation**

- TCNT count timing

- Internal clock source

Bits TPSC2 to TPSC0 in TCR select the system clock ( $\phi$ ) or one of three internal clock sources obtained by prescaling the system clock ( $\phi/2$ ,  $\phi/4$ ,  $\phi/8$ ).

Figure 9.15 shows the timing.



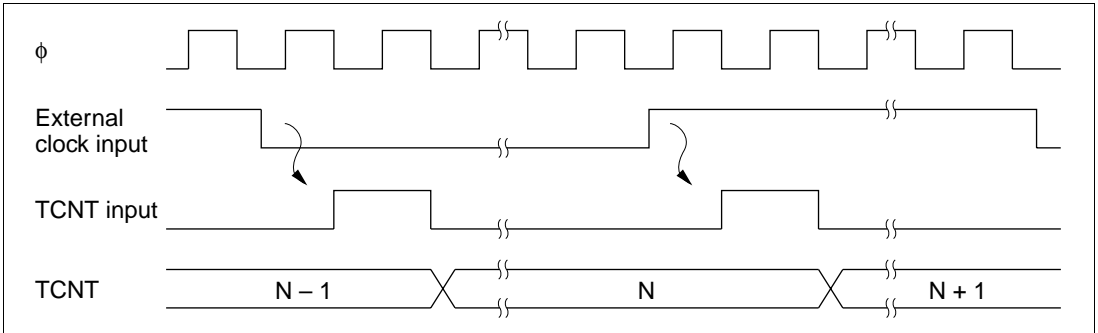
**Figure 9.15 Count Timing for Internal Clock Sources**

— External clock source

Bits TPSC2 to TPSC0 in TCR select an external clock input pin (TCLKA to TCLKD), and its valid edge or edges are selected by bits CKEG1 and CKEG0. The rising edge, falling edge, or both edges can be selected.

The pulse width of the external clock signal must be at least 1.5 system clocks when a single edge is selected, and at least 2.5 system clocks when both edges are selected. Shorter pulses will not be counted correctly.

Figure 9.16 shows the timing when both edges are detected.

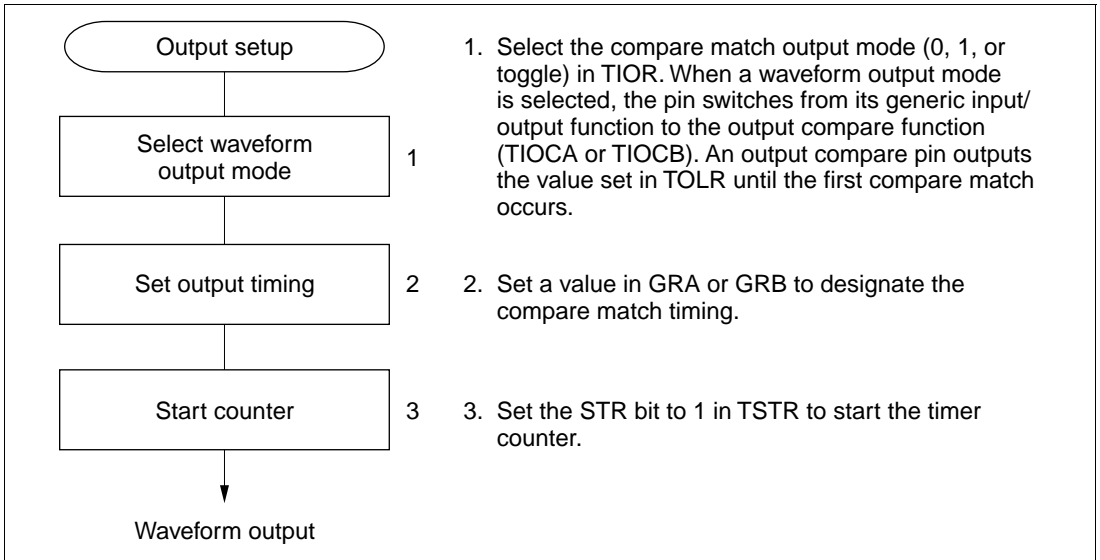


**Figure 9.16 Count Timing for External Clock Sources (when Both Edges are Detected)**

**Waveform Output by Compare Match:** In 16-bit timer channels 0, 1 compare match A or B can cause the output at the TIOCA or TIOCB pin to go to 0, go to 1, or toggle. In channel 2 the output can only go to 0 or go to 1.

- Sample setup procedure for waveform output by compare match

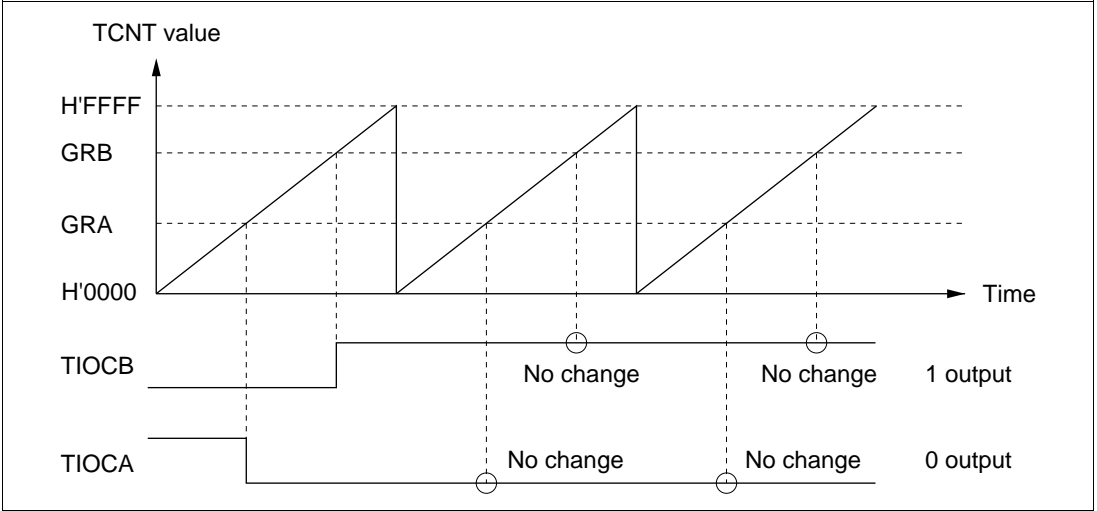
Figure 9.17 shows the timing for detection of both rising and falling edges.



**Figure 9.17 Setup Procedure for Waveform Output by Compare Match (Example)**

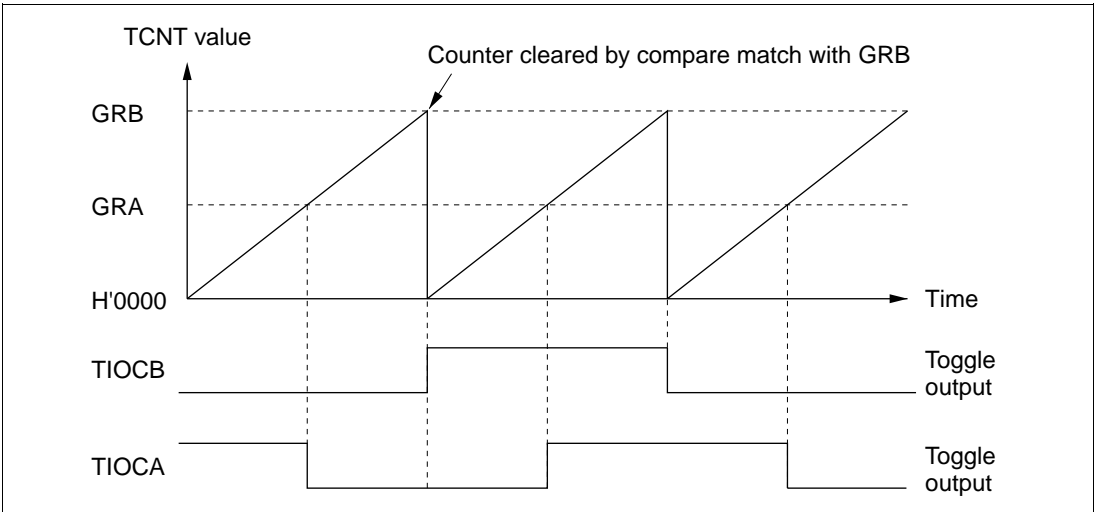
- Examples of waveform output

Figure 9.18 shows examples of 0 and 1 output. TCNT operates as a free-running counter, 0 output is selected for compare match A, and 1 output is selected for compare match B. When the pin is already at the selected output level, the pin level does not change.



**Figure 9.18 0 and 1 Output (TOA = 1, TOB = 0)**

Figure 9.19 shows examples of toggle output. TCNT operates as a periodic counter, cleared by compare match B. Toggle output is selected for both compare match A and B.

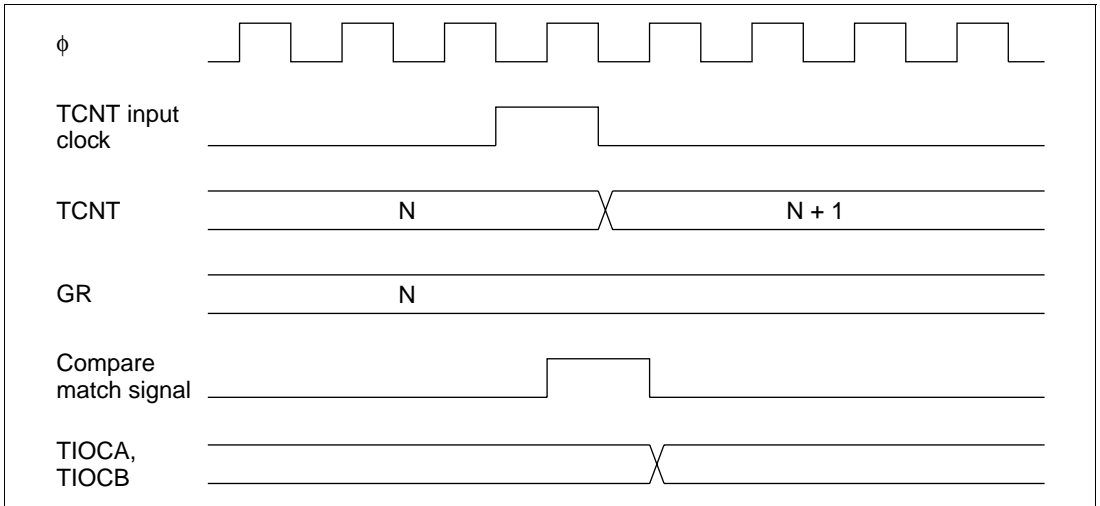


**Figure 9.19 Toggle Output (TOA = 1, TOB = 0)**

- Output compare output timing

The compare match signal is generated in the last state in which TCNT and the general register match (when TCNT changes from the matching value to the next value). When the compare match signal is generated, the output value selected in TIOR is output at the output compare pin (TIOCA or TIOCB). When TCNT matches a general register, the compare match signal is not generated until the next counter clock pulse.

Figure 9.20 shows the output compare timing.

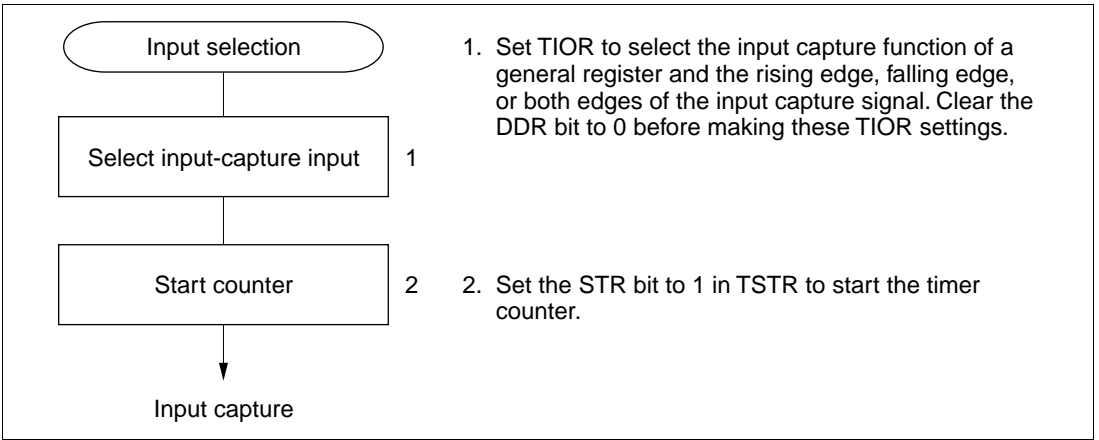


**Figure 9.20 Output Compare Output Timing**

**Input Capture Function:** The TCNT value can be captured into a general register when a transition occurs at an input capture/output compare pin (TIOCA or TIOCB). Capture can take place on the rising edge, falling edge, or both edges. The input capture function can be used to measure pulse width or period.

- Sample setup procedure for input capture

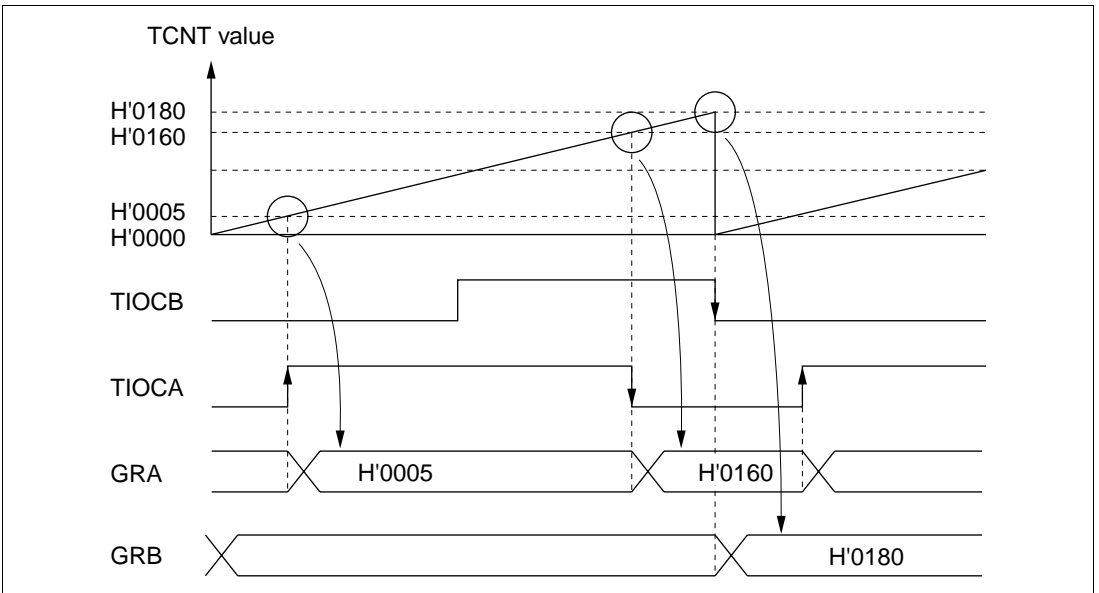
Figure 9.21 shows a sample procedure for setting up input capture.



**Figure 9.21 Setup Procedure for Input Capture (Example)**

- Examples of input capture

Figure 9.22 illustrates input capture when the falling edge of TIOCB and both edges of TIOCA are selected as capture edges. TCNT is cleared by input capture into GRB.

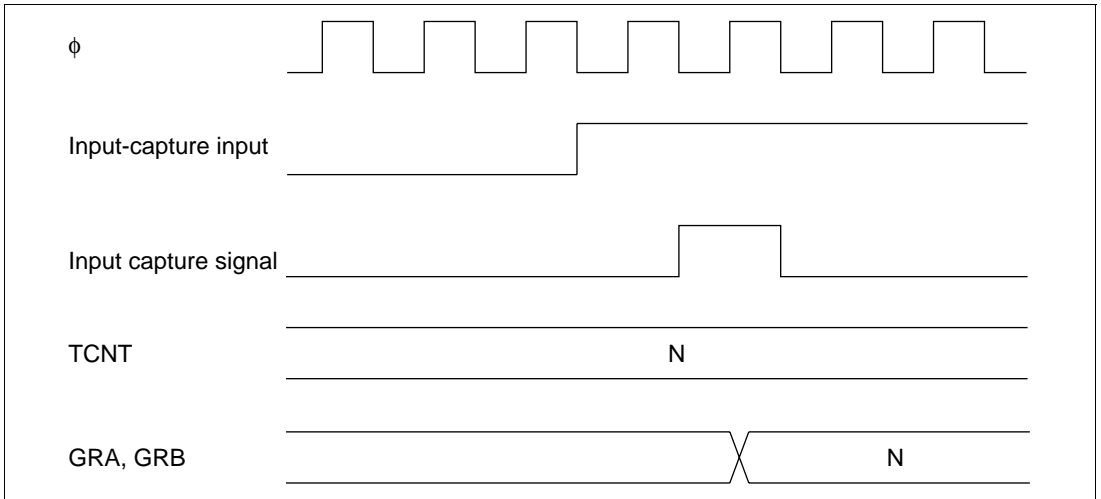


**Figure 9.22 Input Capture (Example)**



- Input capture signal timing

Input capture on the rising edge, falling edge, or both edges can be selected by settings in TIOR. Figure 9.23 shows the timing when the rising edge is selected. The pulse width of the input capture signal must be at least 1.5 system clocks for single-edge capture, and 2.5 system clocks for capture of both edges.

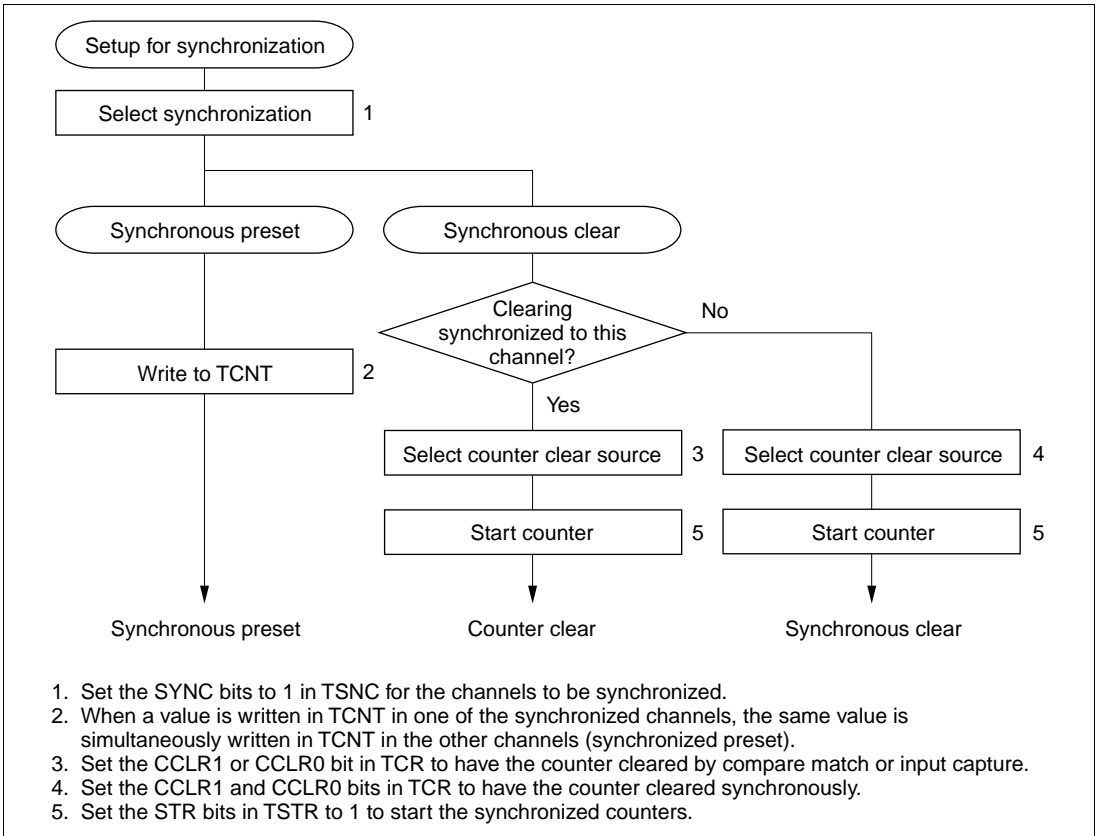


**Figure 9.23 Input Capture Signal Timing**

### 9.4.3 Synchronization

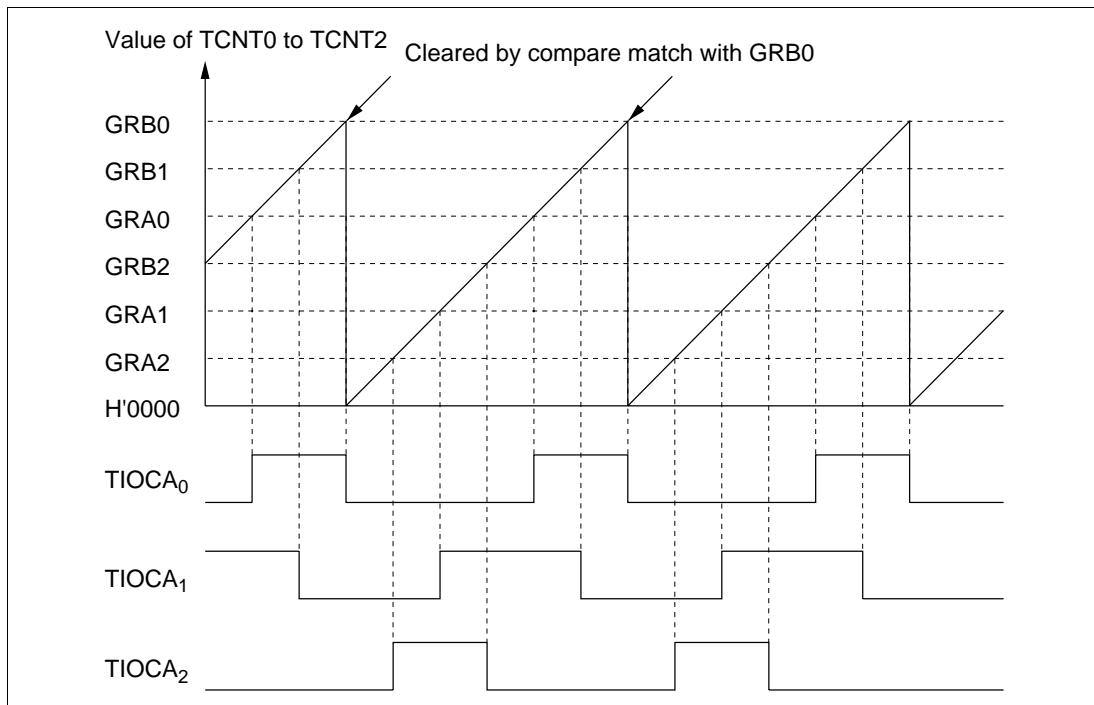
The synchronization function enables two or more timer counters to be synchronized by writing the same data to them simultaneously (synchronous preset). With appropriate TCR settings, two or more timer counters can also be cleared simultaneously (synchronous clear). Synchronization enables additional general registers to be associated with a single time base. Synchronization can be selected for all channels (0 to 2).

**Sample Setup Procedure for Synchronization:** Figure 9.24 shows a sample procedure for setting up synchronization.



**Figure 9.24 Setup Procedure for Synchronization (Example)**

**Example of Synchronization:** Figure 9.25 shows an example of synchronization. Channels 0, 1, and 2 are synchronized, and are set to operate in PWM mode. Channel 0 is set for counter clearing by compare match with GRB0. Channels 1 and 2 are set for synchronous counter clearing. The timer counters in channels 0, 1, and 2 are synchronously preset, and are synchronously cleared by compare match with GRB0. A three-phase PWM waveform is output from pins TIOCA<sub>0</sub>, TIOCA<sub>1</sub>, and TIOCA<sub>2</sub>. For further information on PWM mode, see section 9.4.4, PWM Mode.



**Figure 9.25 Synchronization (Example)**

#### 9.4.4 PWM Mode

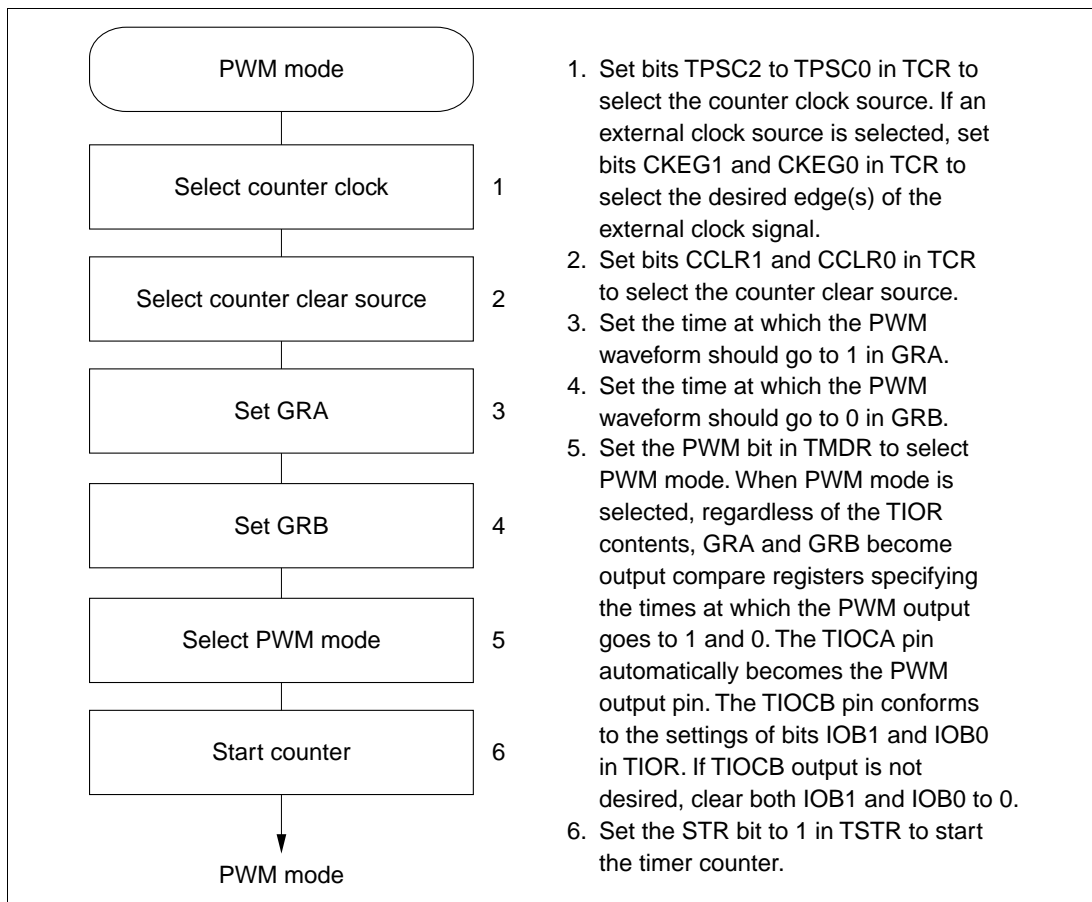
In PWM mode GRA and GRB are paired and a PWM waveform is output from the TIOCA pin. GRA specifies the time at which the PWM output changes to 1. GRB specifies the time at which the PWM output changes to 0. If either GRA or GRB is selected as the counter clear source, a PWM waveform with a duty cycle from 0% to 100% is output at the TIOCA pin. PWM mode can be selected in all channels (0 to 2).

Table 9.4 summarizes the PWM output pins and corresponding registers. If the same value is set in GRA and GRB, the output does not change when compare match occurs.

**Table 9.4 PWM Output Pins and Registers**

<b>Channel</b>	<b>Output Pin</b>	<b>1 Output</b>	<b>0 Output</b>
0	TIOCA <sub>0</sub>	GRA0	GRB0
1	TIOCA <sub>1</sub>	GRA1	GRB1
2	TIOCA <sub>2</sub>	GRA2	GRB2

**Sample Setup Procedure for PWM Mode:** Figure 9.26 shows a sample procedure for setting up PWM mode.

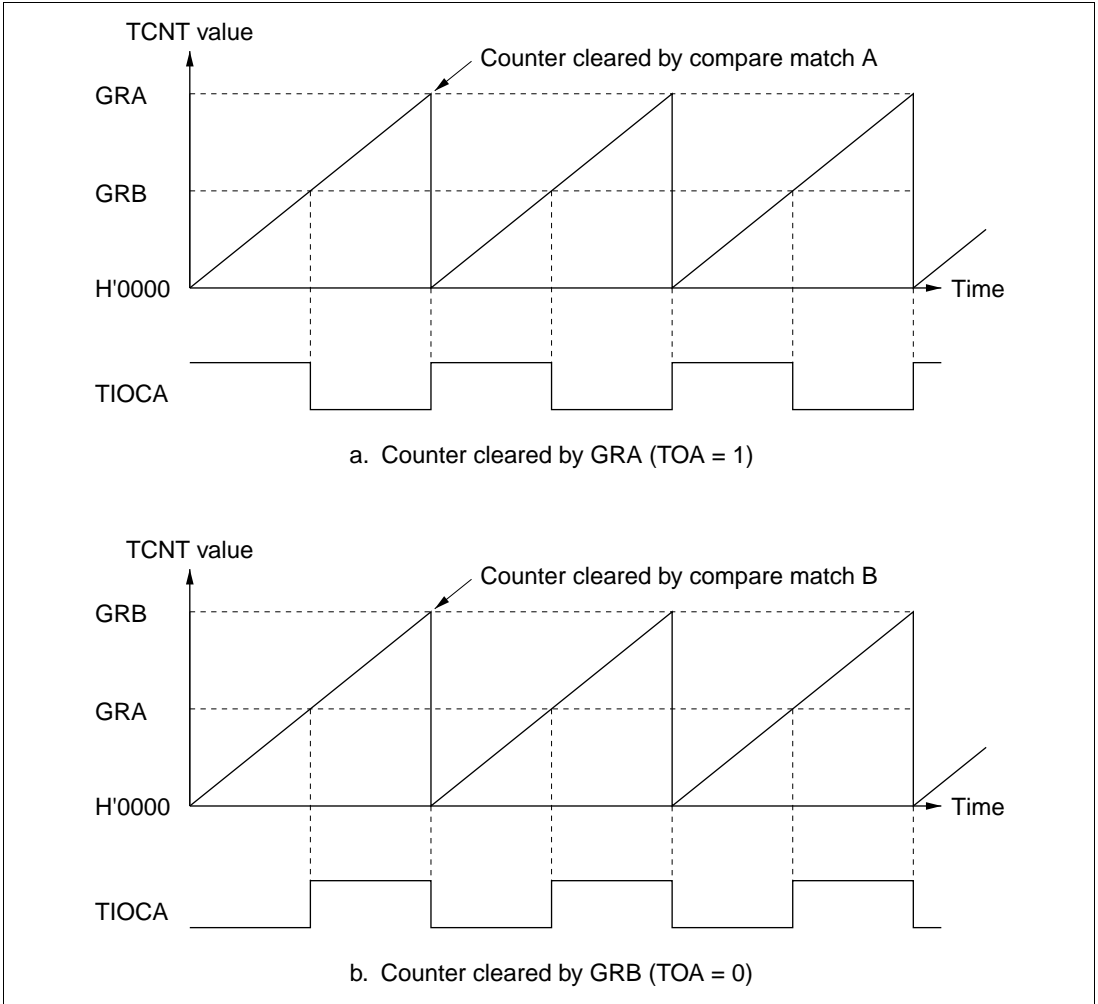


1. Set bits TPSC2 to TPSC0 in TCR to select the counter clock source. If an external clock source is selected, set bits CKEG1 and CKEG0 in TCR to select the desired edge(s) of the external clock signal.
2. Set bits CCLR1 and CCLR0 in TCR to select the counter clear source.
3. Set the time at which the PWM waveform should go to 1 in GRA.
4. Set the time at which the PWM waveform should go to 0 in GRB.
5. Set the PWM bit in TMDR to select PWM mode. When PWM mode is selected, regardless of the TIOR contents, GRA and GRB become output compare registers specifying the times at which the PWM output goes to 1 and 0. The TIOCA pin automatically becomes the PWM output pin. The TIOCB pin conforms to the settings of bits IOB1 and IOB0 in TIOR. If TIOCB output is not desired, clear both IOB1 and IOB0 to 0.
6. Set the STR bit to 1 in TSTR to start the timer counter.

**Figure 9.26 Setup Procedure for PWM Mode (Example)**

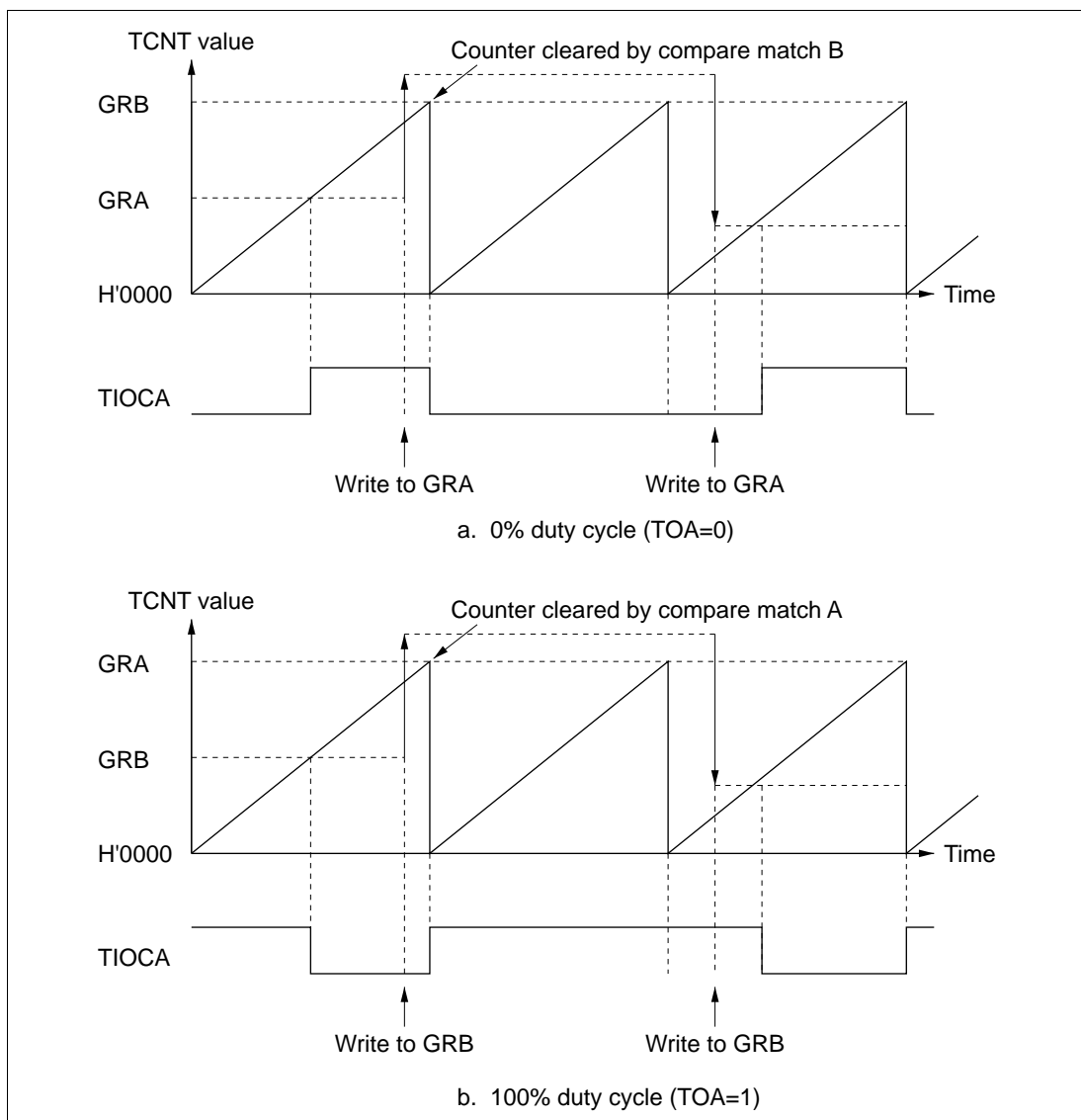
**Examples of PWM Mode:** Figure 9.27 shows examples of operation in PWM mode. In PWM mode TIOCA becomes an output pin. The output goes to 1 at compare match with GRA, and to 0 at compare match with GRB.

In the examples shown, TCNT is cleared by compare match with GRA or GRB. Synchronized operation and free-running counting are also possible.



**Figure 9.27 PWM Mode (Example 1)**

Figure 9.28 shows examples of the output of PWM waveforms with duty cycles of 0% and 100%. If the counter is cleared by compare match with GRB, and GRA is set to a higher value than GRB, the duty cycle is 0%. If the counter is cleared by compare match with GRA, and GRB is set to a higher value than GRA, the duty cycle is 100%.



**Figure 9.28 PWM Mode (Example 2)**

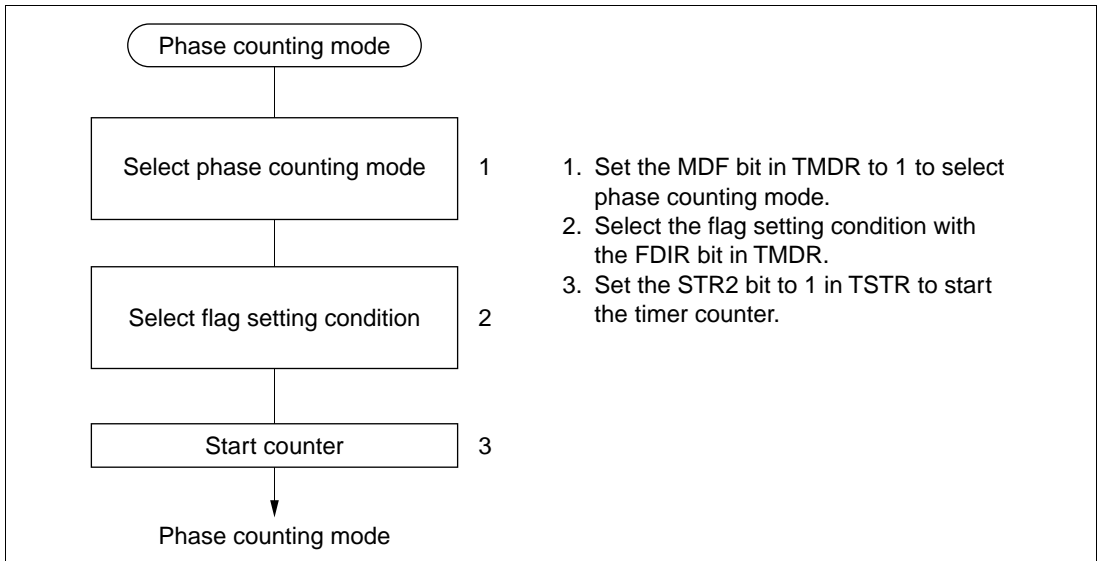
## 9.4.5 Phase Counting Mode

In phase counting mode the phase difference between two external clock inputs (at the TCLKA and TCLKB pins) is detected, and TCNT2 counts up or down accordingly.

In phase counting mode, the TCLKA and TCLKB pins automatically function as external clock input pins and TCNT2 becomes an up/down-counter, regardless of the settings of bits TPSC2 to TPSC0, CKEG1, and CKEG0 in TCR2. Settings of bits CCLR1, CCLR0 in TCR2, and settings in TIOR2, TISRA, TISRB, TISRC, STR2 in TSTR, GRA2, and GRB2 are valid. The input capture and output compare functions can be used, and interrupts can be generated.

Phase counting is available only in channel 2.

**Sample Setup Procedure for Phase Counting Mode:** Figure 9.29 shows a sample procedure for setting up phase counting mode.

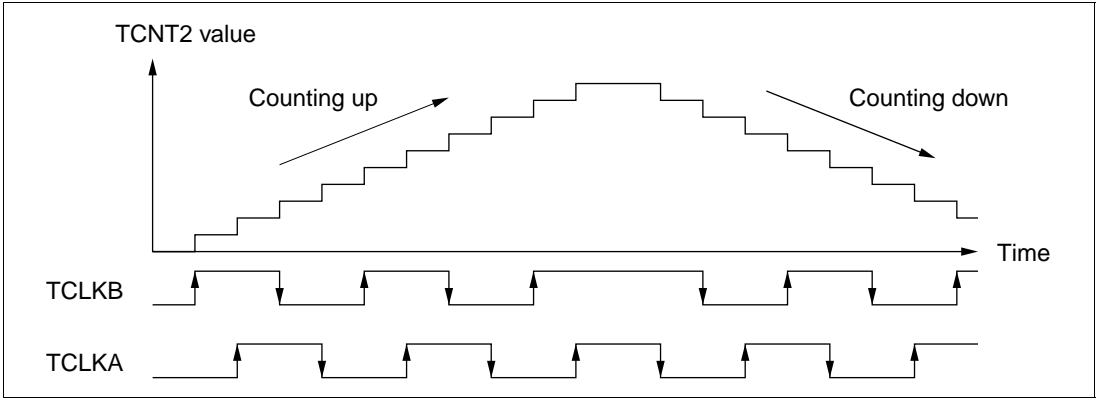


**Figure 9.29 Setup Procedure for Phase Counting Mode (Example)**



**Example of Phase Counting Mode:** Figure 9.30 shows an example of operations in phase counting mode. Table 9.5 lists the up-counting and down-counting conditions for TCNT2.

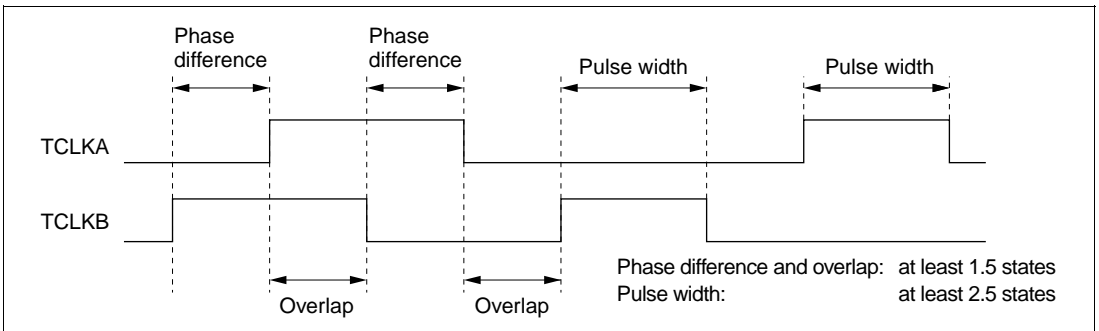
In phase counting mode both the rising and falling edges of TCLKA and TCLKB are counted. The phase difference between TCLKA and TCLKB must be at least 1.5 states, the phase overlap must also be at least 1.5 states, and the pulse width must be at least 2.5 states.



**Figure 9.30 Operation in Phase Counting Mode (Example)**

**Table 9.5 Up/Down Counting Conditions**

Counting Direction	Up-Counting				Down-Counting			
TCLKB pin	↓	High	↑	Low	High	↓	Low	↓
TCLKA pin	Low	↓	High	↑	↑	Low	↓	High



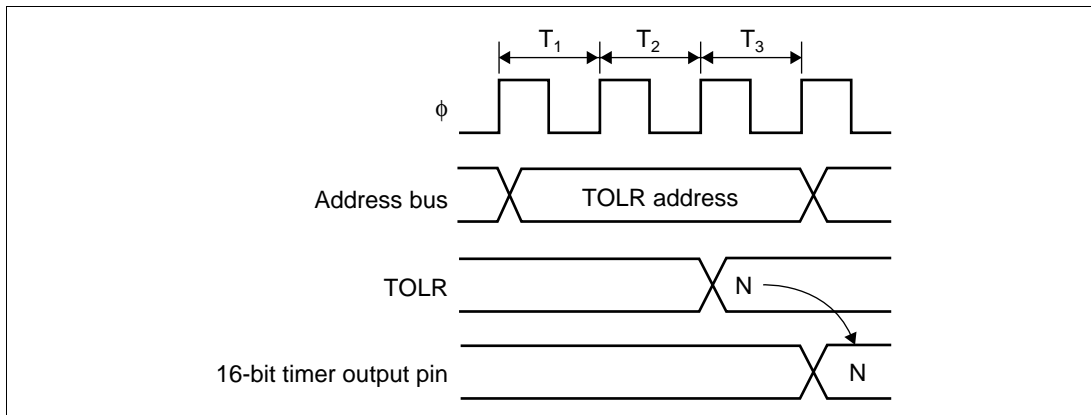
**Figure 9.31 Phase Difference, Overlap, and Pulse Width in Phase Counting Mode**

## 9.4.6 Setting Initial Value of 16-Bit Timer Output

Any desired value can be specified for the initial 16-bit timer output value when a timer count operation is started by making a setting in TOLR.

Figure 9.32 shows the timing for setting the initial output value with TOLR.

Only write to TOLR when the corresponding bit in TSTR is cleared to 0.



**Figure 9.32 Example of Timing for Setting Initial Value of 16-Bit Timer Output by Writing to TOLR**

## 9.5 Interrupts

The 16-bit timer has two types of interrupts: input capture/compare match interrupts, and overflow interrupts.

### 9.5.1 Setting of Status Flags

**Timing of Setting of IMFA and IMFB at Compare Match:** IMFA and IMFB are set to 1 by a compare match signal generated when TCNT matches a general register (GR). The compare match signal is generated in the last state in which the values match (when TCNT is updated from the matching count to the next count). Therefore, when TCNT matches a general register, the compare match signal is not generated until the next TCNT clock input. Figure 9.33 shows the timing of the setting of IMFA and IMFB.

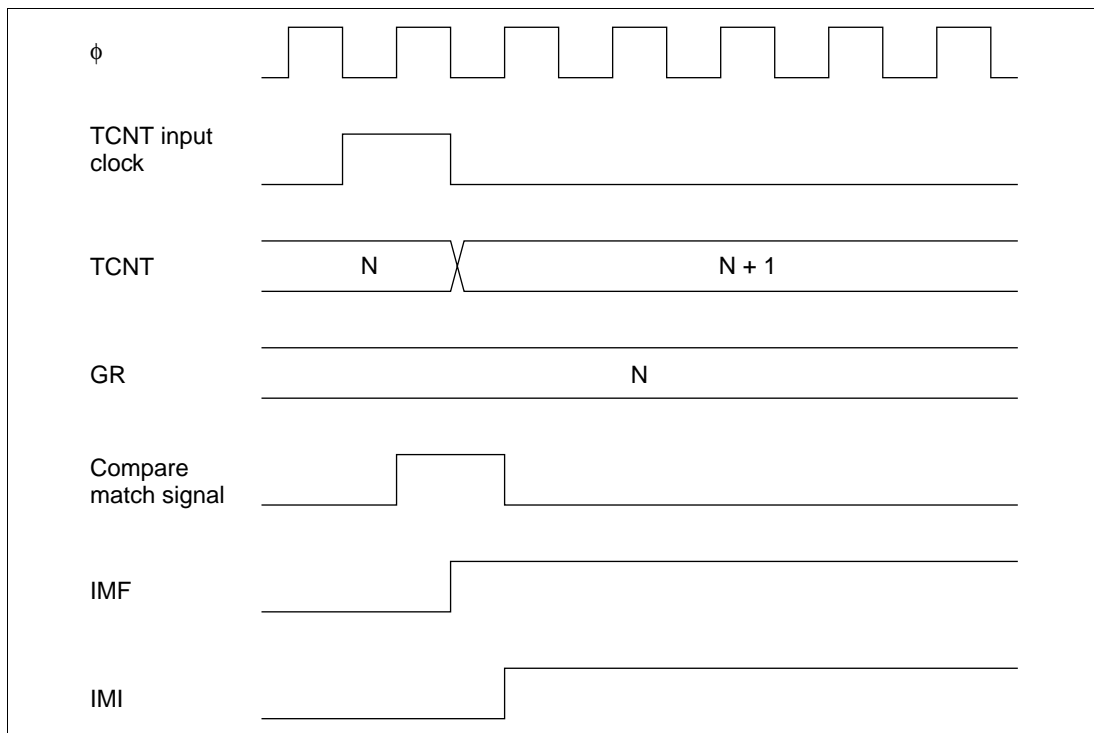
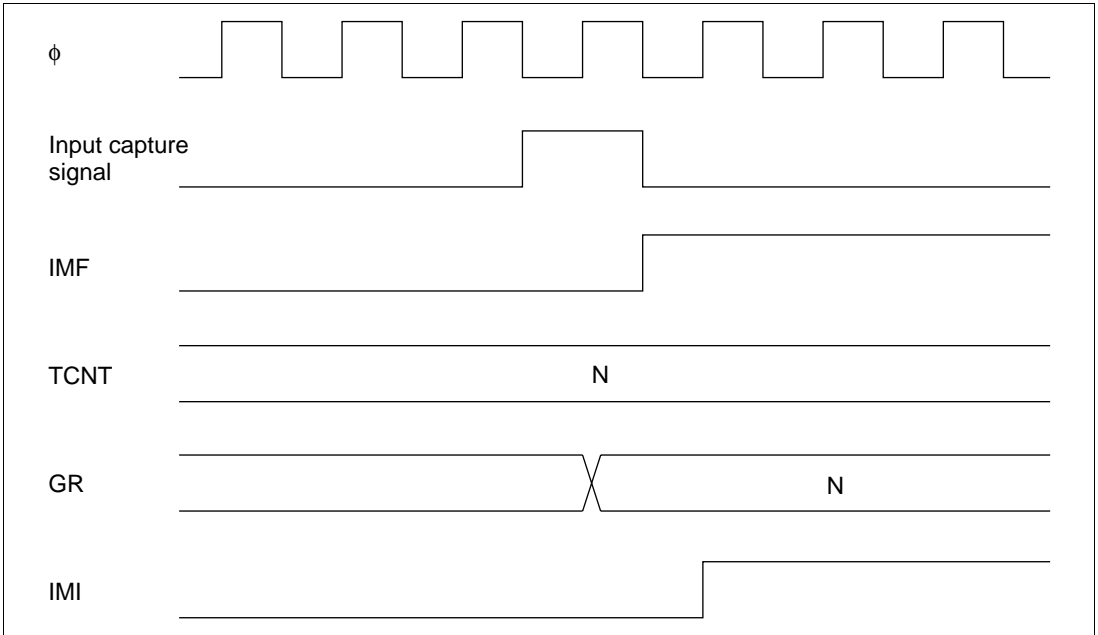


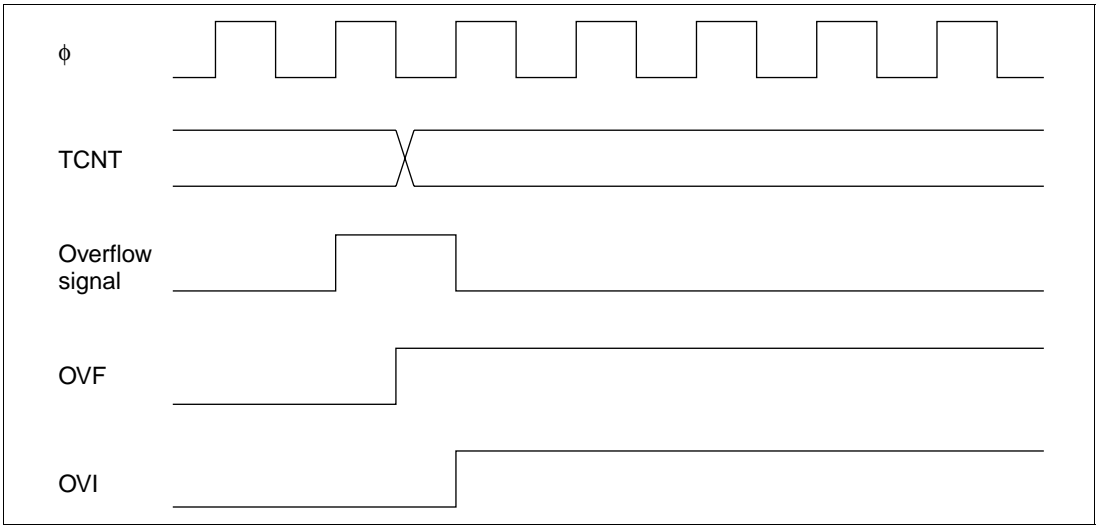
Figure 9.33 Timing of Setting of IMFA and IMFB by Compare Match

**Timing of Setting of IMFA and IMFB by Input Capture:** IMFA and IMFB are set to 1 by an input capture signal. The TCNT contents are simultaneously transferred to the corresponding general register. Figure 9.34 shows the timing.



**Figure 9.34 Timing of Setting of IMFA and IMFB by Input Capture**

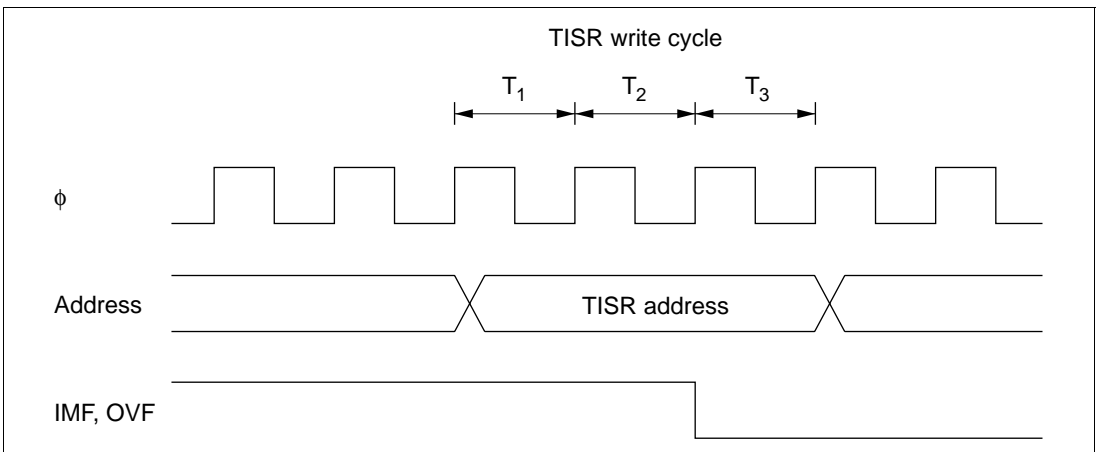
**Timing of Setting of Overflow Flag (OVF):** OVF is set to 1 when TCNT overflows from H'FFFF to H'0000 or underflows from H'0000 to H'FFFF. Figure 9.35 shows the timing.



**Figure 9.35 Timing of Setting of OVF**

### 9.5.2 Timing of Clearing of Status Flags

If the CPU reads a status flag while it is set to 1, then writes 0 in the status flag, the status flag is cleared. Figure 9.36 shows the timing.



**Figure 9.36 Timing of Clearing of Status Flags**

### 9.5.3 Interrupt Sources and DMA Controller Activation


Each 16-bit timer channel can generate a compare match/input capture A interrupt, a compare match/input capture B interrupt, and an overflow interrupt. In total there are nine interrupt sources of three kinds, all independently vectored. An interrupt is requested when the interrupt request flag are set to 1.

The priority order of the channels can be modified in interrupt priority register A (IPRA). For details see section 5, Interrupt Controller.

Compare match/input capture A interrupts in channels 0 to 2 can activate the DMA controller (DMAC). When the DMAC is activated a CPU interrupt is not requested.

Table 9.6 lists the interrupt sources.

**Table 9.6 16-bit timer Interrupt Sources**

Channel	Interrupt Source	Description	DMAC Activatable	Priority*
0	IMIA0	Compare match/input capture A0	Yes	
	IMIB0	Compare match/input capture B0	No	
	OVI0	Overflow 0	No	
1	IMIA1	Compare match/input capture A1	Yes	
	IMIB1	Compare match/input capture B1	No	
	OVI1	Overflow 1	No	
2	IMIA2	Compare match/input capture A2	Yes	
	IMIB2	Compare match/input capture B2	No	
	OVI2	Overflow 2	No	

Note: \* The priority immediately after a reset is indicated. Inter-channel priorities can be changed by settings in IPRA.

## 9.6 Usage Notes

This section describes contention and other matters requiring special attention during 16-bit timer operations.

**Contention between TCNT Write and Clear:** If a counter clear signal occurs in the  $T_3$  state of a TCNT write cycle, clearing of the counter takes priority and the write is not performed. See figure 9.37.

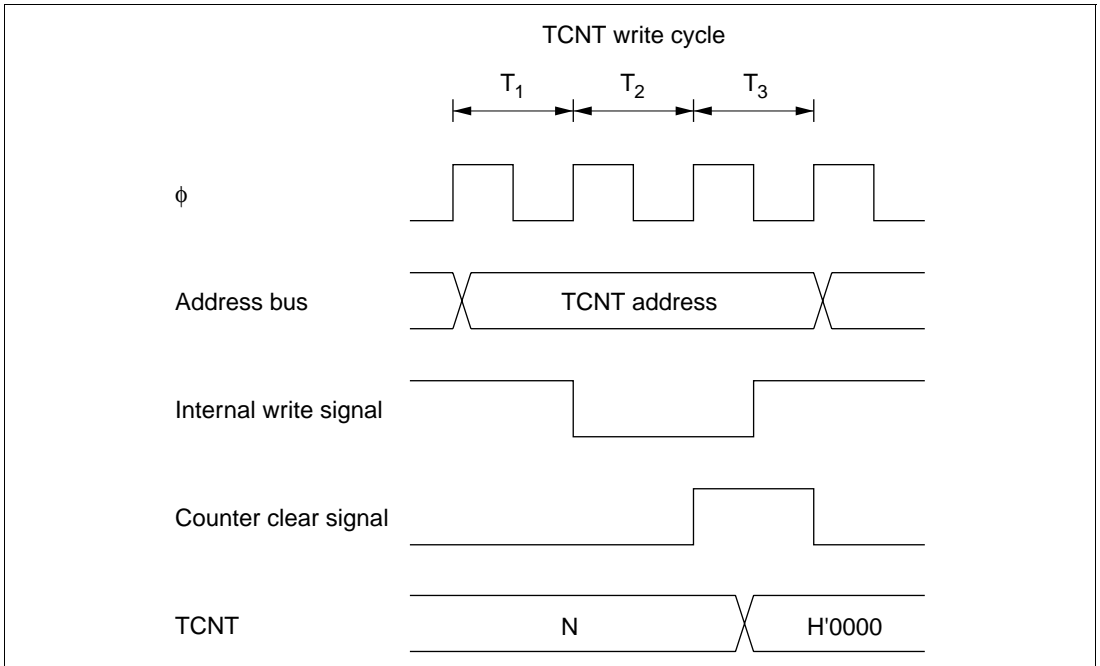
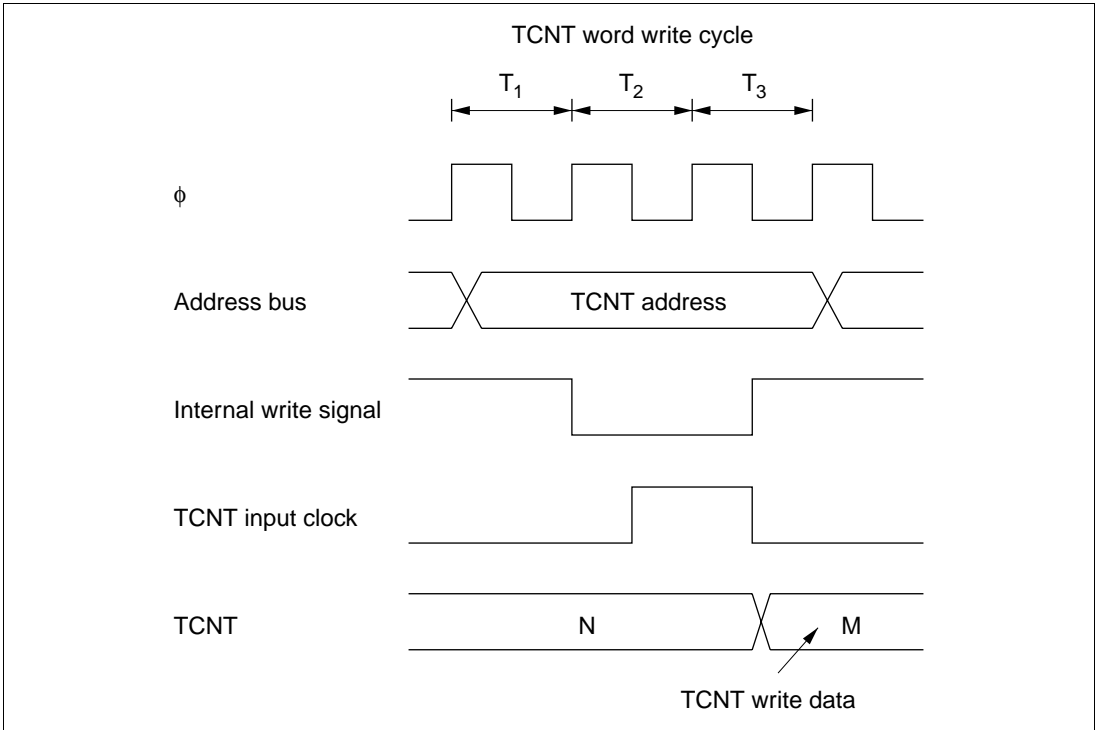


Figure 9.37 Contention between TCNT Write and Clear

**Contention between TCNT Word Write and Increment:** If an increment pulse occurs in the  $T_3$  state of a TCNT word write cycle, writing takes priority and TCNT is not incremented.

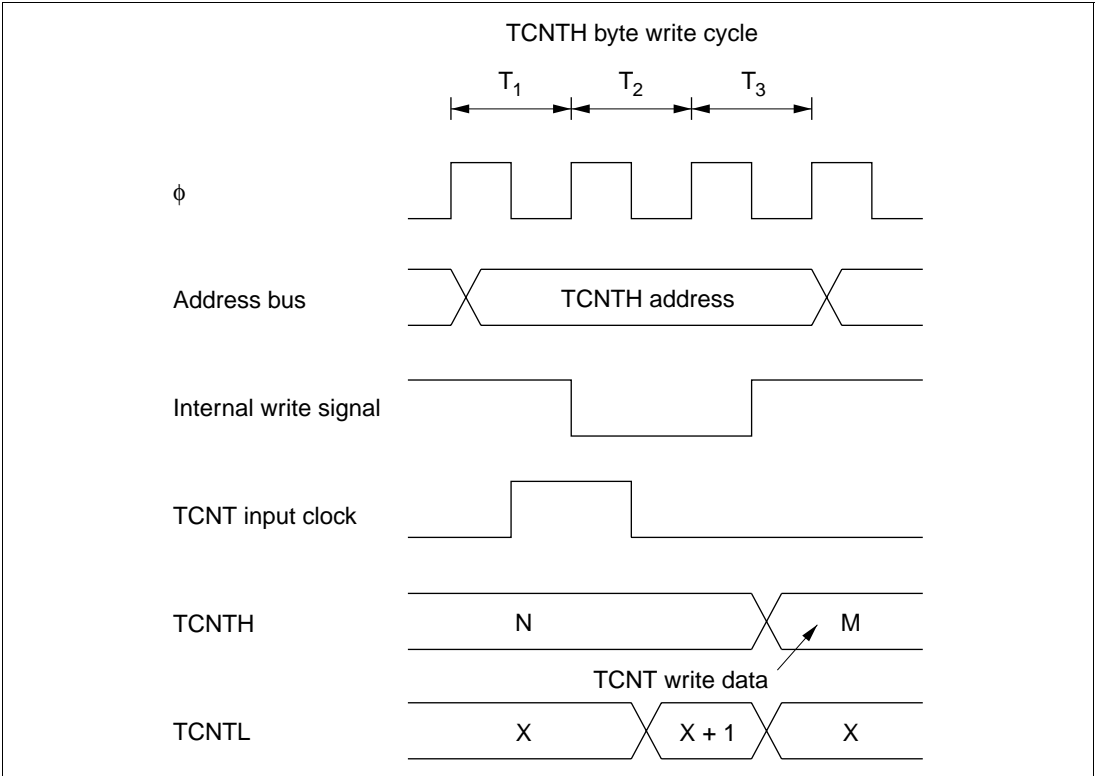
Figure 9.38 shows the timing in this case.



**Figure 9.38** Contention between TCNT Word Write and Increment

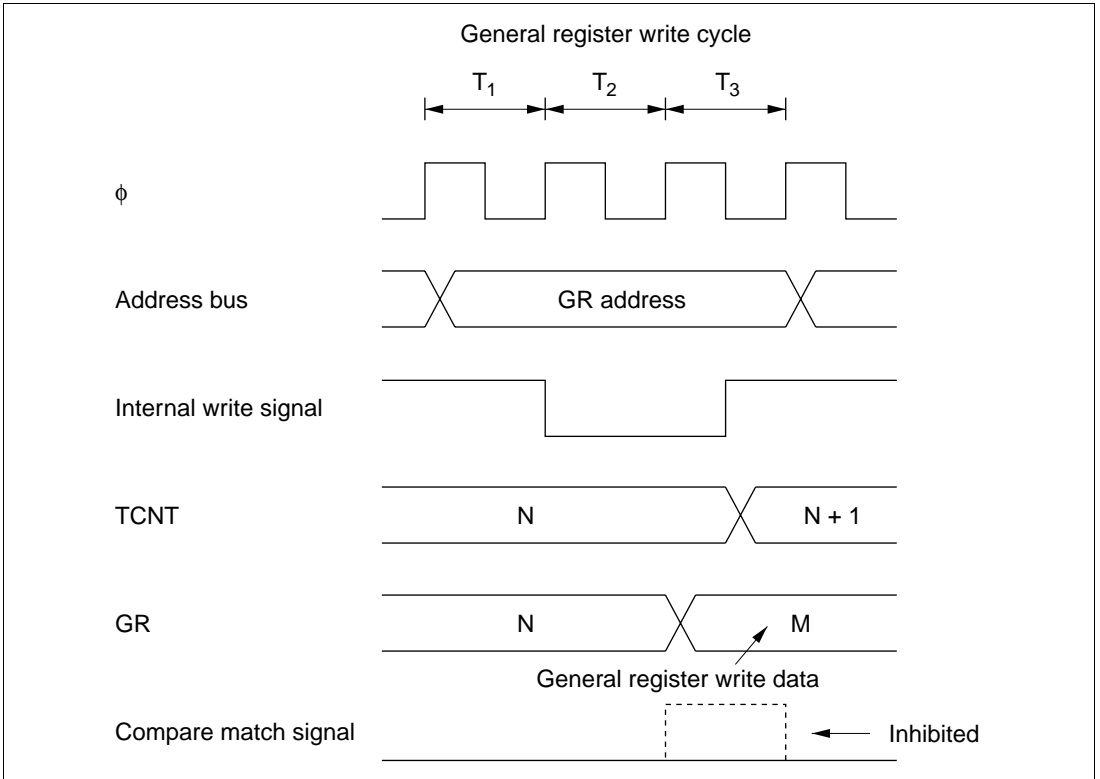


**Contention between TCNT Byte Write and Increment:** If an increment pulse occurs in the  $T_2$  or  $T_3$  state of a TCNT byte write cycle, writing takes priority and TCNT is not incremented. The TCNT byte that was not written retains its previous value. See figure 9.39, which shows an increment pulse occurring in the  $T_2$  state of a byte write to TCNTH.



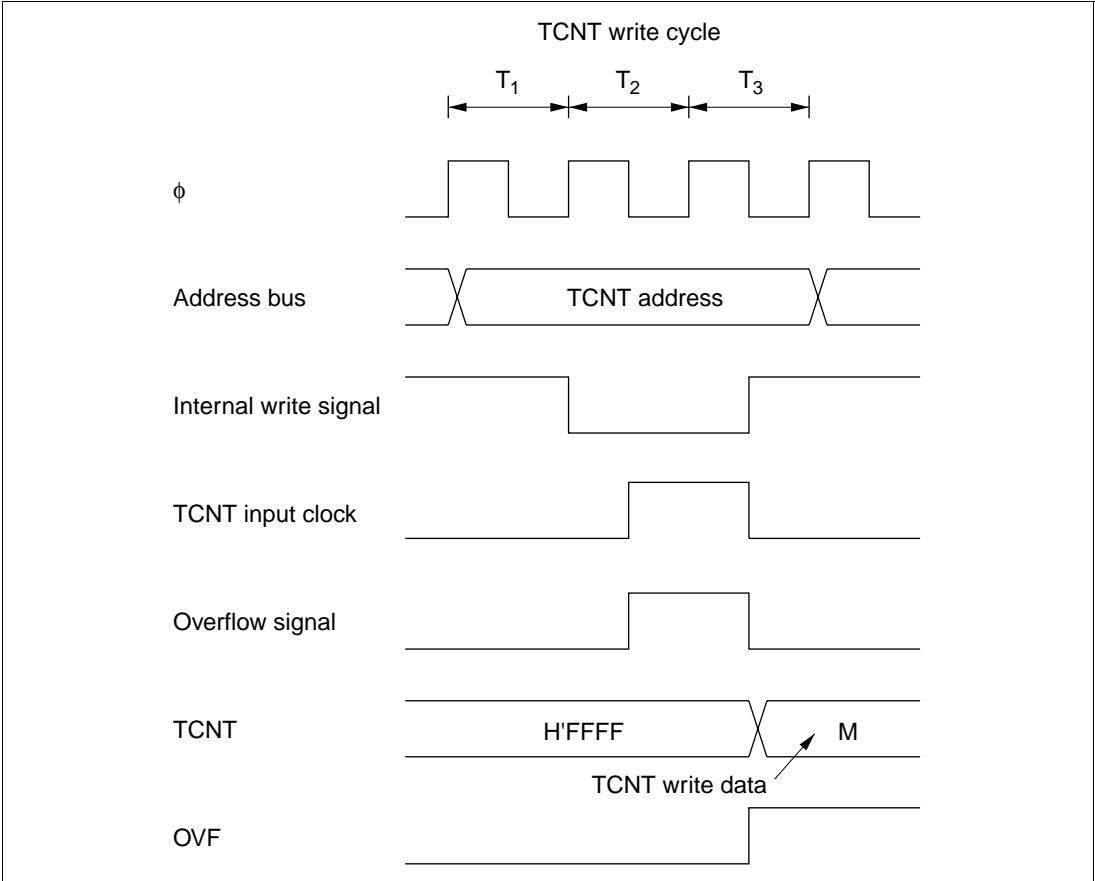
**Figure 9.39** Contention between TCNT Byte Write and Increment

**Contention between General Register Write and Compare Match:** If a compare match occurs in the  $T_3$  state of a general register write cycle, writing takes priority and the compare match signal is inhibited. See figure 9.40.



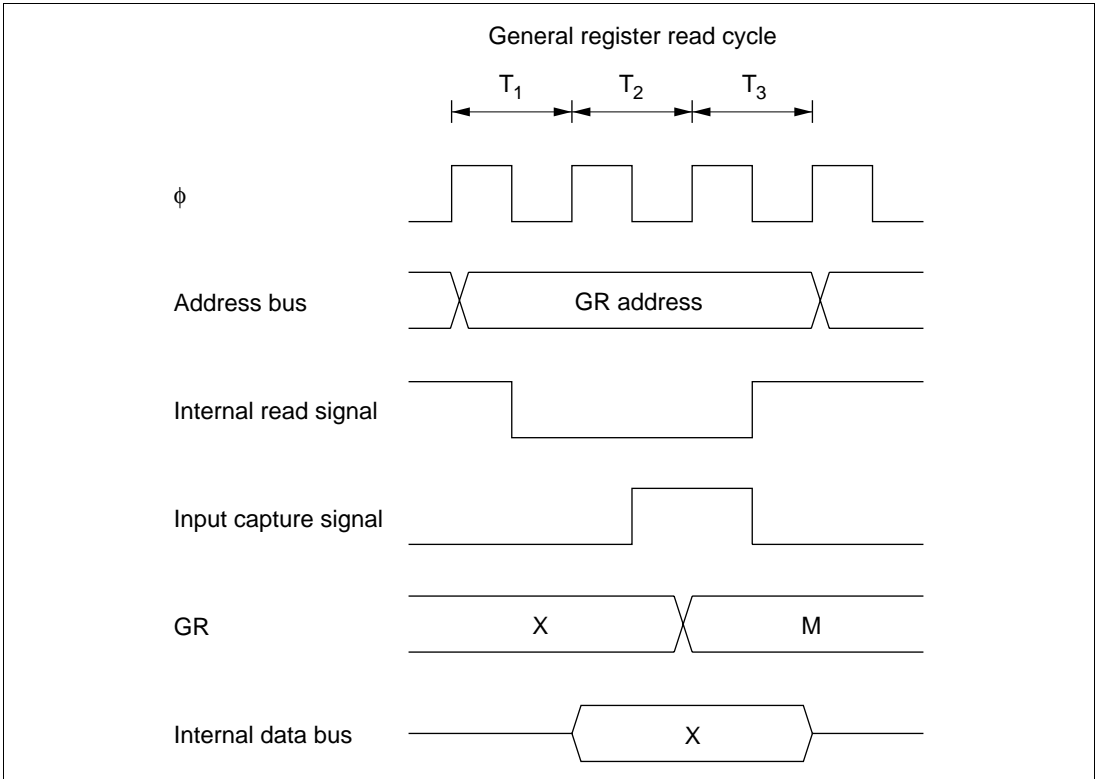
**Figure 9.40 Contention between General Register Write and Compare Match**

**Contention between TCNT Write and Overflow or Underflow:** If an overflow occurs in the  $T_3$  state of a TCNT write cycle, writing takes priority and the counter is not incremented. OVF is set to 1. The same holds for underflow. See figure 9.41.



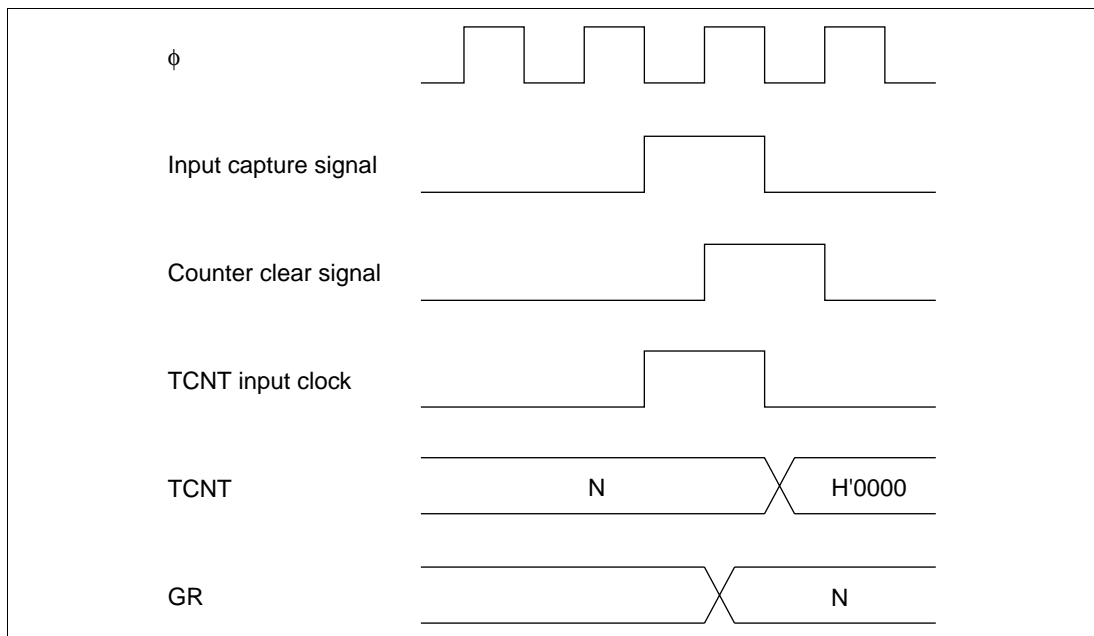
**Figure 9.41 Contention between TCNT Write and Overflow**

**Contention between General Register Read and Input Capture:** If an input capture signal occurs during the  $T_3$  state of a general register read cycle, the value before input capture is read. See figure 9.42.



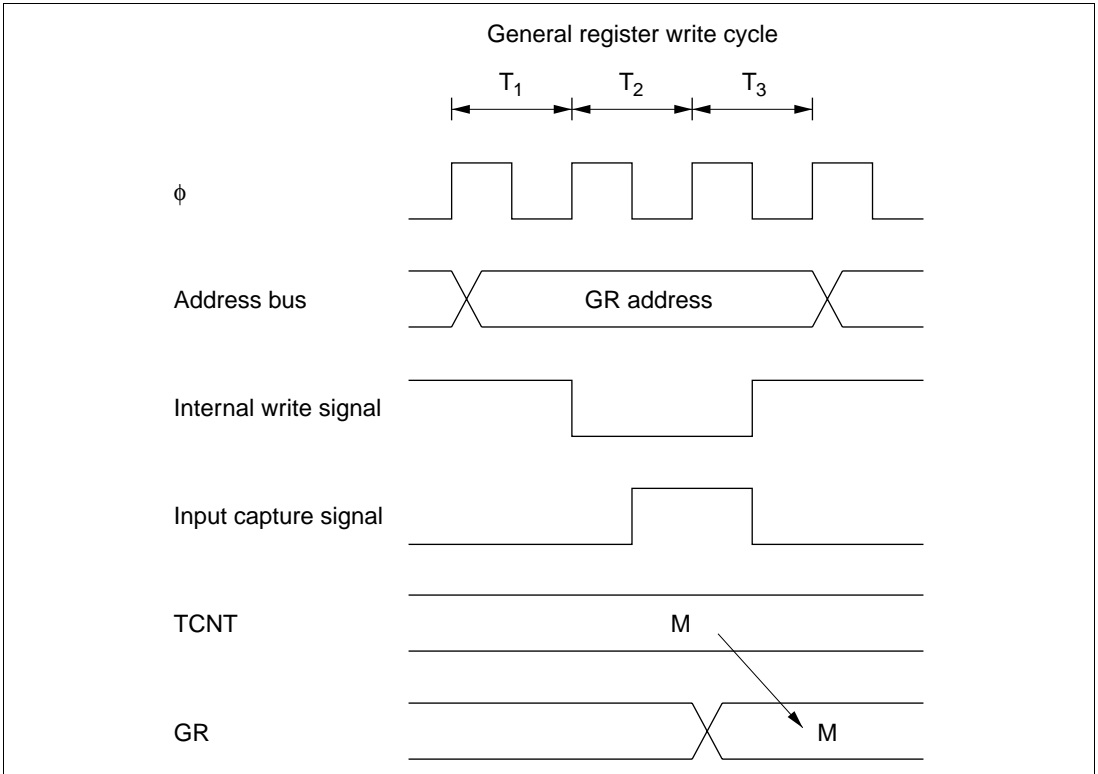
**Figure 9.42 Contention between General Register Read and Input Capture**

**Contention between Counter Clearing by Input Capture and Counter Increment:** If an input capture signal and counter increment signal occur simultaneously, the counter is cleared according to the input capture signal. The counter is not incremented by the increment signal. The counter is not incremented by the increment signal. The value before the counter is cleared is transferred to the general register. See figure 9.43.



**Figure 9.43 Contention between Counter Clearing by Input Capture and Counter Increment**

**Contention between General Register Write and Input Capture:** If an input capture signal occurs in the  $T_3$  state of a general register write cycle, input capture takes priority and the write to the general register is not performed. See figure 9.44.



**Figure 9.44 Contention between General Register Write and Input Capture**

**Note on Waveform Period Setting:** When a counter is cleared by compare match, the counter is cleared in the last state at which the TCNT value matches the general register value, at the time when this value would normally be updated to the next count. The actual counter frequency is therefore given by the following formula:

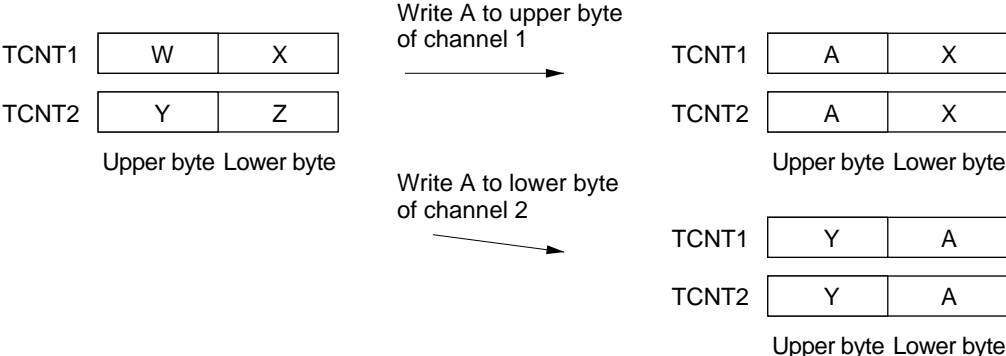
$$f = \frac{\phi}{(N+1)}$$

(f: counter frequency.  $\phi$ : system clock frequency. N: value set in general register.)

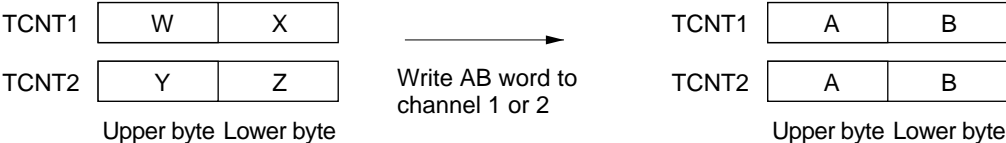
**Note on Writes in Synchronized Operation:** When channels are synchronized, if a TCNT value is modified by byte write access, all 16 bits of all synchronized counters assume the same value as the counter that was addressed.

(Example) When channels 1 and 2 are synchronized

- Byte write to channel 1 or byte write to channel 2



- Word write to channel 1 or word write to channel 2



## 16-bit timer Operating Modes:

**Table 9.7 (a) 16-bit timer Operating Modes (Channel 0)**

Operating Mode		Register Settings								
		TSNC		TMDR			TIOR0		TCR0	
		Synchro- nization	MDF	FDIR	PWM	IOA	IOB	Clear Select	Clock Select	
Synchronous preset		SYNC0 = 1	—	—	○	○	○	○	○	
PWM mode		○	—	—	PWM0 = 1	—	○*	○	○	
Output compare A		○	—	—	PWM0 = 0	IOA2 = 0 Other bits unrestricted	○	○	○	
Output compare B		○	—	—	○	○	IOB2 = 0 Other bits unrestricted	○	○	
Input capture A		○	—	—	PWM0 = 0	IOA2 = 1 Other bits unrestricted	○	○	○	
Input capture B		○	—	—	PWM0 = 0	○	IOB2 = 1 Other bits unrestricted	○	○	
Counter clearing	By compare match/input capture A	○	—	—	○	○	○	CCLR1 = 0 CCLR0 = 1	○	
	By compare match/input capture B	○	—	—	○	○	○	CCLR1 = 1 CCLR0 = 0	○	
	Syn- chronous clear	SYNC0 = 1	—	—	○	○	○	CCLR1 = 1 CCLR0 = 1	○	

Legend: ○ Setting available (valid). — Setting does not affect this mode.

Note: \* The input capture function cannot be used in PWM mode. If compare match A and compare match B occur simultaneously, the compare match signal is inhibited.



**Table 9.7 (b) 16-bit timer Operating Modes (Channel 1)**

Operating Mode		Register Settings							
		TSNC	TMDR			TIOR1		TCR1	
		Synchro- nization	MDF	FDIR	PWM	IOA	IOB	Clear Select	Clock Select
Synchronous preset	○	—	—	○	○	○	○	○	
PWM mode	○	—	—	PWM1 = 1	—	○*	○	○	
Output compare A	○	—	—	PWM1 = 0	IOA2 = 0 Other bits unrestricted	○	○	○	
Output compare B	○	—	—	○	○	IOB2 = 0 Other bits unrestricted	○	○	
Input capture A	○	—	—	PWM1 = 0	IOA2 = 1 Other bits unrestricted	○	○	○	
Input capture B	○	—	—	PWM1 = 0	○	IOB2 = 1 Other bits unrestricted	○	○	
Counter clearing	By compare match/input capture A	○	—	—	○	○	○	CCLR1 = 0 CCLR0 = 1	
	By compare match/input capture B	○	—	—	○	○	○	CCLR1 = 1 CCLR0 = 0	
	Syn-chronous clear	SYNC1 = 1	—	—	○	○	○	CCLR1 = 1 CCLR0 = 1	

Legend: ○ Setting available (valid). — Setting does not affect this mode.

Notes: \* The input capture function cannot be used in PWM mode. If compare match A and compare match B occur simultaneously, the compare match signal is inhibited.

**Table 9.7 (c) 16-bit timer Operating Modes (Channel 2)**

Operating Mode		Register Settings								
		TSNC		TMDR			TIOR2		TCR2	
		Synchro- nization	MDF	FDIR	PWM	IOA	IOB	Clear Select	Clock Select	
Synchronous preset	SYNC2 = 1	○	—	○	○	○	○	○	○	
PWM mode	○	○	—	PWM2 = 1	—	○*	○	○		
Output compare A	○	○	—	PWM2 = 0	IOA2 = 0 Other bits unrestricted	○	○	○		
Output compare B	○	○	—	○	○	IOB2 = 0 Other bits unrestricted	○	○		
Input capture A	○	○	—	PWM2 = 0	IOA2 = 1 Other bits unrestricted	○	○	○		
Input capture B	○	○	—	PWM2 = 0	○	IOB2 = 1 Other bits unrestricted	○	○		
Counter clearing	By compare match/input capture A	○	○	—	○	○	○	CCLR1 = 0 CCLR0 = 1		
	By compare match/input capture B	○	○	—	○	○	○	CCLR1 = 1 CCLR0 = 0		
	Syn-chronous clear	SYNC2 = 1	○	—	○	○	○	CCLR1 = 1 CCLR0 = 1		
Phase counting mode	○	MDF = 1	○	○	○	○	○	—		

Legend: ○ Setting available (valid). — Setting does not affect this mode.

Note: \* The input capture function cannot be used in PWM mode. If compare match A and compare match B occur simultaneously, the compare match signal is inhibited.

# Section 10 8-Bit Timers

## 10.1 Overview

The H8/3067 Series has a built-in 8-bit timer module with four channels (TMR0, TMR1, TMR2, and TMR3), based on 8-bit counters. Each channel has an 8-bit timer counter (TCNT) and two 8-bit time constant registers (TCORA and TCORB) that are constantly compared with the TCNT value to detect compare match events. The timers can be used as multifunctional timers in a variety of applications, including the generation of a rectangular-wave output with an arbitrary duty cycle.

### 10.1.1 Features

The features of the 8-bit timer module are listed below.

- Selection of four clock sources  
The counters can be driven by one of three internal clock signals ( $\phi/8$ ,  $\phi/64$ , or  $\phi/8192$ ) or an external clock input (enabling use as an external event counter).
- Selection of three ways to clear the counters  
The counters can be cleared on compare match A or B, or input capture B.
- Timer output controlled by two compare match signals  
The timer output signal in each channel is controlled by two independent compare match signals, enabling the timer to generate output waveforms with an arbitrary duty cycle or PWM output.
- A/D converter can be activated by a compare match
- Two channels can be cascaded
  - Channels 0 and 1 can be operated as the upper and lower halves of a 16-bit timer (16-bit count mode).
  - Channels 2 and 3 can be operated as the upper and lower halves of a 16-bit timer (16-bit count mode).
  - Channel 1 can count channel 0 compare match events (compare match count mode).
  - Channel 3 can count channel 2 compare match events (compare match count mode).
- Input capture function can be set  
8-bit or 16-bit input capture operation is available.
- Twelve interrupt sources  
There are twelve interrupt sources: four compare match sources, four compare match/input capture sources, four overflow sources.

Two of the compare match sources and two of the combined compare match/input capture sources each have an independent interrupt vector. The remaining compare match interrupts, combined compare match/input capture interrupts, and overflow interrupts have one interrupt vector for two sources.

## 10.1.2 Block Diagram

The 8-bit timers are divided into two groups of two channels each: group 0 comprising channels 0 and 1, and group 1 comprising channels 2 and 3. Figure 10.1 shows a block diagram of 8-bit timer group 0.

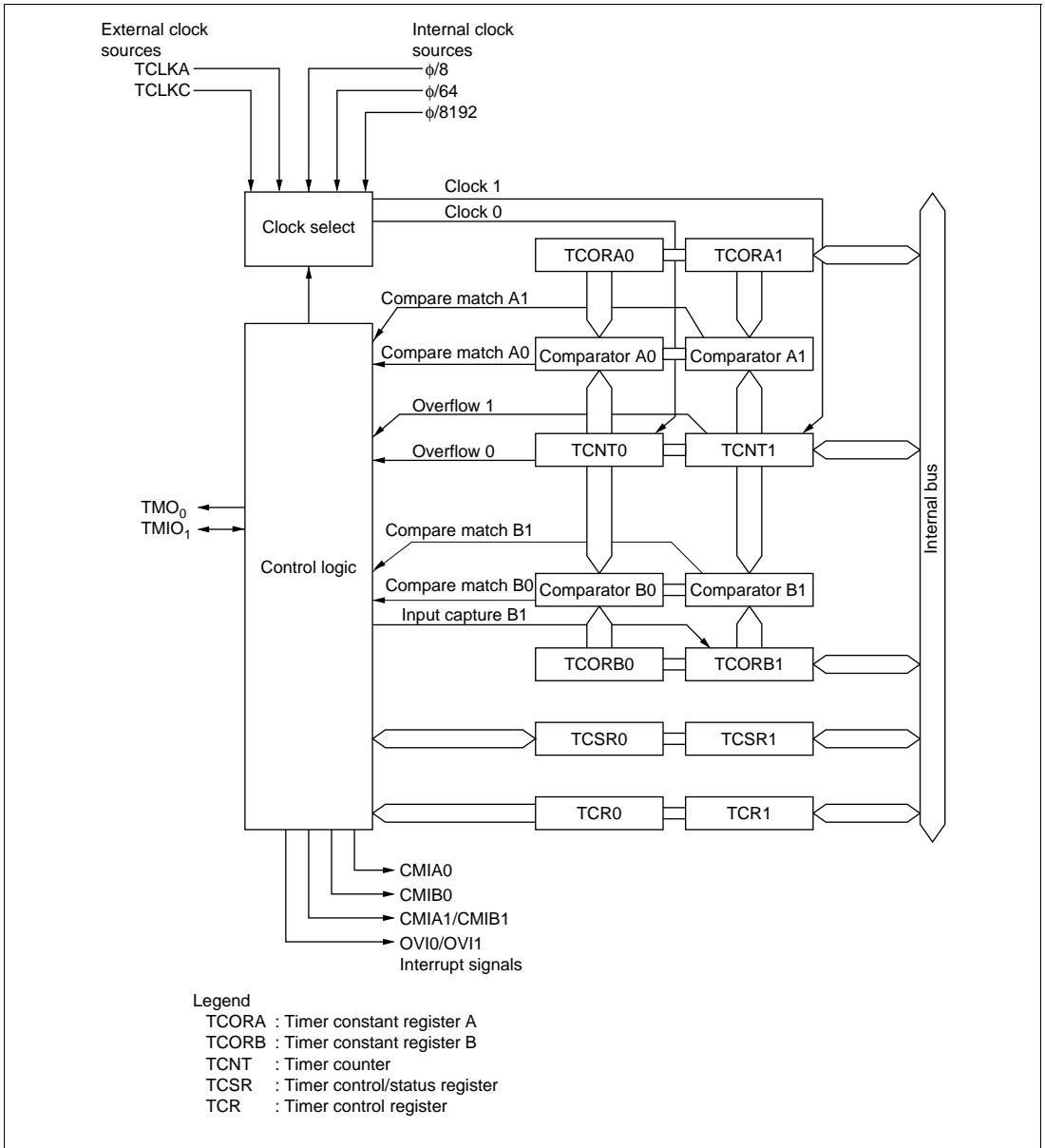


Figure 10.1 Block Diagram of 8-Bit Timer Unit (Two Channels: Group 0)

### 10.1.3 Pin Configuration

Table 10.1 summarizes the input/output pins of the 8-bit timer module.

**Table 10.1 8-Bit Timer Pins**

Group	Channel	Name	Abbreviation	I/O	Input/output
0	0	Timer output	TMO <sub>0</sub>	Output	Compare match output
		Timer clock input	TCLKC	Input	Counter external clock input
	1	Timer input/output	TMIO <sub>1</sub>	I/O	Compare match output/input capture input
		Timer clock input	TCLKA	Input	Counter external clock input
1	2	Timer output	TMO <sub>2</sub>	Output	Compare match output
		Timer clock input	TCLKD	Input	Counter external clock input
	3	Timer input/output	TMIO <sub>3</sub>	I/O	Compare match output/input capture input
		Timer clock input	TCLKB	Input	Counter external clock input

## 10.1.4 Register Configuration

Table 10.2 summarizes the registers of the 8-bit timer module.

**Table 10.2 8-Bit Timer Registers**

Channel	Address*1	Name	Abbreviation	R/W	Initial value
0	H'FFF80	Timer control register 0	TCR0	R/W	H'00
	H'FFF82	Timer control/status register 0	TCSR0	R/(W)*2	H'00
	H'FFF84	Timer constant register A0	TCORA0	R/W	H'FF
	H'FFF86	Timer constant register B0	TCORB0	R/W	H'FF
	H'FFF88	Timer counter 0	TCNT0	R/W	H'00
1	H'FFF81	Timer control register 1	TCR1	R/W	H'00
	H'FFF83	Timer control/status register 1	TCSR1	R/(W)*2	H'00
	H'FFF85	Timer constant register A1	TCORA1	R/W	H'FF
	H'FFF87	Timer constant register B1	TCORB1	R/W	H'FF
	H'FFF89	Timer counter 1	TCNT1	R/W	H'00
2	H'FFF90	Timer control register 2	TCR2	R/W	H'00
	H'FFF92	Timer control/status register 2	TCSR2	R/(W)*2	H'00
	H'FFF94	Timer constant register A2	TCORA2	R/W	H'FF
	H'FFF96	Timer constant register B2	TCORB2	R/W	H'FF
	H'FFF98	Timer counter 2	TCNT2	R/W	H'00
3	H'FFF91	Timer control register 3	TCR3	R/W	H'00
	H'FFF93	Timer control/status register 3	TCSR3	R/(W)*2	H'00
	H'FFF95	Timer constant register A3	TCORA3	R/W	H'FF
	H'FFF97	Timer constant register B3	TCORB3	R/W	H'FF
	H'FFF99	Timer counter 3	TCNT3	R/W	H'00

Notes: 1. Indicates the lower 20 bits of the address in advanced mode.

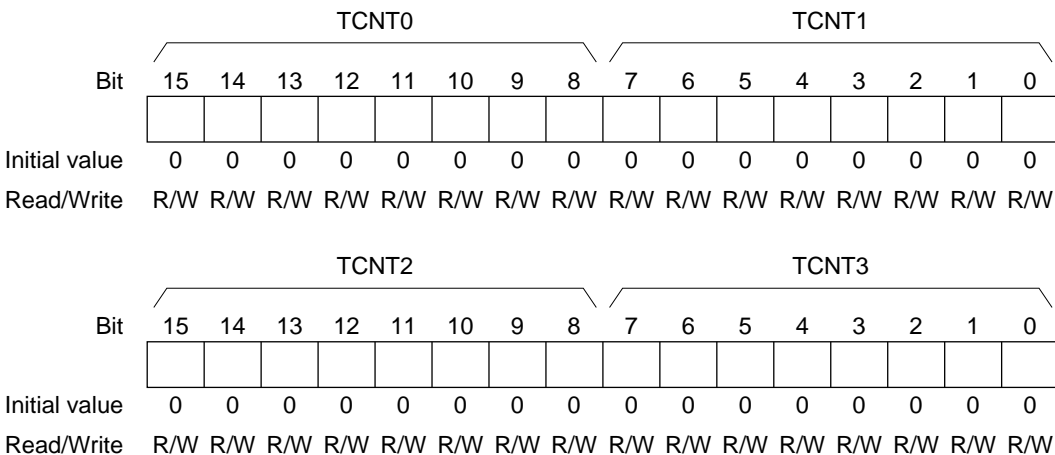
2. Only 0 can be written to bits 7 to 5, to clear these flags.

Each pair of registers for channel 0 and channel 1 comprises a 16-bit register with the channel 0 register as the upper 8 bits and the channel 1 register as the lower 8 bits, so they can be accessed together by word access.

Similarly, each pair of registers for channel 2 and channel 3 comprises a 16-bit register with the channel 2 register as the upper 8 bits and the channel 3 register as the lower 8 bits, so they can be accessed together by word access.

## 10.2 Register Descriptions

### 10.2.1 Timer Counters (TCNT)



The timer counters (TCNT) are 8-bit readable/writable up-counters that increment on pulses generated from an internal or external clock source. The clock source is selected by clock select bits 2 to 0 (CKS2 to CKS0) in the timer control register (TCR). The CPU can always read or write to the timer counters.

The TCNT0 and TCNT1 pair, and the TCNT2 and TCNT3 pair, can each be accessed as a 16-bit register by word access.

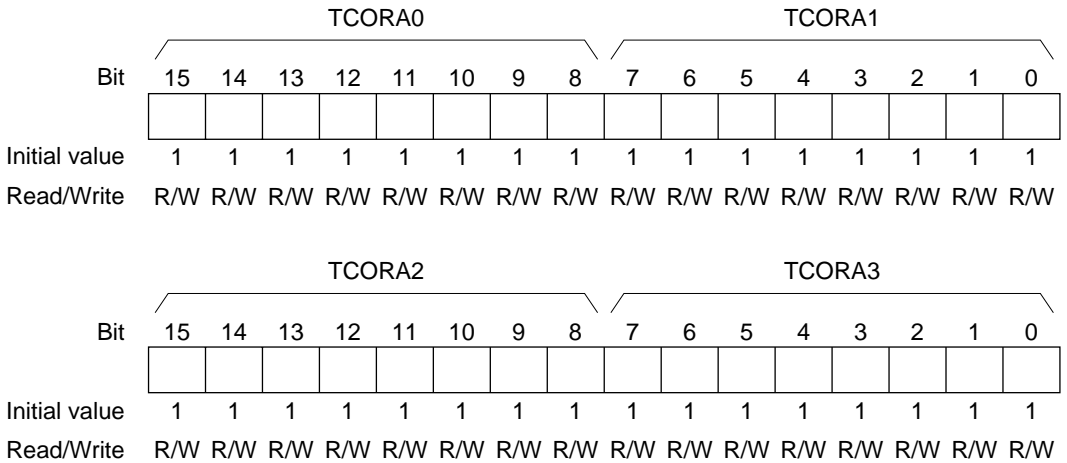
TCNT can be cleared by an input capture signal or compare match signal. Counter clear bits 1 and 0 (CCLR1 and CCLR0) in TCR select the method of clearing.

When TCNT overflows from H'FF to H'00, the overflow flag (OVF) in the timer control/status register (TCSR) is set to 1.

Each TCNT is initialized to H'00 by a reset and in standby mode.



## 10.2.2 Time Constant Registers A (TCORA)



TCORA0 to TCORA3 are 8-bit readable/writable registers. The TCORA0 and TCORA1 pair, and the TCORA2 and TCORA3 pair, can each be accessed as a 16-bit register by word access.

The TCORA value is constantly compared with the TCNT value. When a match is detected, the corresponding compare match flag A (CMFA) is set to 1 in TCSR.

The timer output can be freely controlled by these compare match signals and the settings of output select bits 1 and 0 (OS1, OS0) in TCSR.

Each TCORA register is initialized to H'FF by a reset and in standby mode.

### 10.2.3 Time Constant Registers B (TCORB)

TCORB0								TCORB1								
Bit	15	14	13	12	11	10	9	8	7	6	5	4	3	2	1	0
Initial value	1	1	1	1	1	1	1	1	1	1	1	1	1	1	1	1
Read/Write	R/W	R/W	R/W	R/W	R/W	R/W	R/W	R/W	R/W	R/W	R/W	R/W	R/W	R/W	R/W	R/W

TCORB2								TCORB3								
Bit	15	14	13	12	11	10	9	8	7	6	5	4	3	2	1	0
Initial value	1	1	1	1	1	1	1	1	1	1	1	1	1	1	1	1
Read/Write	R/W	R/W	R/W	R/W	R/W	R/W	R/W	R/W	R/W	R/W	R/W	R/W	R/W	R/W	R/W	R/W

TCORB0 to TCORB3 are 8-bit readable/writable registers. The TCORB0 and TCORB1 pair, and the TCORB2 and TCORB3 pair, can each be accessed as a 16-bit register by word access.

The TCORB value is constantly compared with the TCNT value. When a match is detected, the corresponding compare match flag B (CMFB) is set to 1 in TCSR.

The timer output can be freely controlled by these compare match signals and the settings of output/input capture edge select bits 3 and 2 (OIS3, OIS2) in TCSR.

When TCORB is used for input capture, it stores the TCNT value on detection of an external input capture signal. At this time, the CMFB flag is set to 1 in the corresponding TCSR register. The detected edge of the input capture signal is set in TCSR.

Each TCORB register is initialized to H'FF by a reset and in standby mode.

### 10.2.4 Timer Control Register (TCR)

Bit	7	6	5	4	3	2	1	0
	CMIEB	CMIEA	OVIE	CCLR1	CCLR0	CKS2	CKS1	CKS0
Initial value	0	0	0	0	0	0	0	0
Read/Write	R/W	R/W	R/W	R/W	R/W	R/W	R/W	R/W

TCR is an 8-bit readable/writable register that selects the input clock source and the time at which TCNT is cleared, and enables interrupts.

TCR is initialized to H'00 by a reset and in standby mode.

For the timing, see section 10.4, Operation.

**Bit 7—Compare Match Interrupt Enable B (CMIEB):** Enables or disables the CMIB interrupt request when the CMFB flag is set to 1 in TCSR.

**Bit 7**

CMIEB	Description
0	CMIB interrupt requested by CMFB is disabled (Initial value)
1	CMIB interrupt requested by CMFB is enabled

**Bit 6—Compare Match Interrupt Enable A (CMIEA):** Enables or disables the CMIA interrupt request when the CMFA flag is set to 1 in TCSR.

**Bit 6**

CMIEA	Description
0	CMIA interrupt requested by CMFA is disabled (Initial value)
1	CMIA interrupt requested by CMFA is enabled

**Bit 5—Timer Overflow Interrupt Enable (OVIE):** Enables or disables the OVI interrupt request when the OVF flag is set to 1 in TCSR.

**Bit 5**

OVIE	Description
0	OVI interrupt requested by OVF is disabled (Initial value)
1	OVI interrupt requested by OVF is enabled

**Bits 4 and 3—Counter Clear 1 and 0 (CCLR1 and CCLR0):** These bits select how TCNT is cleared: by compare match A or B, or input capture B..

**Bit 4      Bit 3**

CCLR1	CCLR0	Description
0	0	Clearing is disabled (Initial value)
	1	Cleared by compare match A
1	0	Cleared by compare match B/ input capture B
	1	Cleared by input capture B

**Bits 2 to 0—Clock Select 2 to 0 (CSK2 to CSK0):** These bits select whether the clock input to TCNT is an internal or external clock.

Three internal clocks can be selected, all divided from the system clock ( $\phi$ ):  $\phi/8$ ,  $\phi/64$ , and  $\phi/8192$ . The rising edge of the selected internal clock triggers the count.

When use of an external clock is selected, three types of count can be selected: at the rising edge, the falling edge, and both rising and falling edges.

Some functions differ between channels 0 and 2 and channels 1 and 3.

Bit 2 CKS2	Bit 1 CKS1	Bit 0 CKS0	Description
0	0	0	Clock input disabled (Initial value)
		1	Internal clock, counted on rising edge of $\phi/8$
	1	0	Internal clock, counted on rising edge of $\phi/64$
		1	Internal clock, counted on rising edge of $\phi/8192$
1	0	0	Channel 0: Count on TCNT1 overflow signal* <sup>1</sup> Channel 1: Count on TCNT0 compare match A* <sup>1</sup> Channel 2: Count on TCNT3 overflow signal* <sup>2</sup> Channel 3: Count on TCNT2 compare match A* <sup>2</sup>
		1	External clock, counted on falling edge
	1	0	External clock, counted on rising edge
		1	External clock, counted on both rising and falling edges

- Notes:
1. If the clock input of channel 0 is the TCNT1 overflow signal and that of channel 1 is the TCNT0 compare match signal, no incrementing clock is generated. Do not use this setting.
  2. If the clock input of channel 2 is the TCNT3 overflow signal and that of channel 3 is the TCNT2 compare match signal, no incrementing clock is generated. Do not use this setting.

## 10.2.5 Timer Control/Status Registers (TCSR)

### TCSR0

Bit	7	6	5	4	3	2	1	0
	CMFB	CMFA	OVF	ADTE	OIS3	OIS2	OS1	OS0
Initial value	0	0	0	0	0	0	0	0
Read/Write	R/(W)*	R/(W)*	R/(W)*	R/W	R/W	R/W	R/W	R/W

### TCSR2

Bit	7	6	5	4	3	2	1	0
	CMFB	CMFA	OVF	—	OIS3	OIS2	OS1	OS0
Initial value	0	0	0	1	0	0	0	0
Read/Write	R/(W)*	R/(W)*	R/(W)*	—	R/W	R/W	R/W	R/W

### TCSR1, TCSR3

Bit	7	6	5	4	3	2	1	0
	CMFB	CMFA	OVF	ICE	OIS3	OIS2	OS1	OS0
Initial value	0	0	0	0	0	0	0	0
Read/Write	R/(W)*	R/(W)*	R/(W)*	R/W	R/W	R/W	R/W	R/W

Note: \* Only 0 can be written to bits 7 to 5, to clear these flags.

The timer control/status registers (TCSR0 to TCSR3) are 8-bit registers that indicate compare match/input capture and overflow statuses, and control compare match output/input capture edge selection.

Each TCSR is initialized to H'00 by a reset and in standby mode.

**Bit 7—Compare Match/Input Capture Flag B (CMFB):** Status flag that indicates the occurrence of a TCORB compare match or input capture.

#### Bit 7

CMFB	Description	(Initial value)
0	Clearing condition Read CMFB when CMFB = 1, then write 0 in CMFB	
1	Setting conditions TCNT = TCORB The TCNT value is transferred to TCORB by an input capture signal when TCORB functions as an input capture register	

**Bit 6—Compare Match Flag A (CMFA):** Status flag that indicates the occurrence of a TCORA compare match.

Bit 6 CMFA	Description	
0	Clearing condition Read CMFA when CMFA = 1, then write 0 in CMFA	(Initial value)
1	Setting condition TCNT = TCORA	

**Bit 5—Timer Overflow Flag (OVF):** Status flag that indicates that the TCNT has overflowed (from H'FF to H'00).

Bit 5 OVF	Description	
0	Clearing condition Read OVF when OVF = 1, then write 0 in OVF	(Initial value)
1	Setting condition TCNT overflows from H'FF to H'00	

**Bit 4—A/D Trigger Enable (ADTE) (TCSR0):** In combination with TRGE in the A/D control register (ADCR), enables or disables A/D converter start requests by compare match A or an external trigger. TCSR2 is a reserved bit, but can be read and written.

TRGE*	Bit 4 ADTE	Description
0	0	A/D converter start requests by compare match A or an external trigger are disabled (Initial value)
	1	A/D converter start requests by compare match A or an external trigger are disabled
1	0	A/D converter start requests by an external trigger are enabled, and A/D converter start requests by compare match A are disabled
	1	A/D converter start requests by compare match A are enabled, and A/D converter start requests by an external trigger are disabled

Note: \* TRGE is bit 7 of the A/D control register (ADCR).

**Bit 4—Input Capture Enable (ICE) (TCSR1, TCSR3):** Selects the function of TCORB.

**Bit 4**

ICE	Description
0	TCORB is a compare match register (Initial value)
1	TCORB is an input capture register

**Bits 3 and 2—Output/Input Capture Edge Select B3 and B2 (OIS3, OIS2):** In combination with the ICE bit in TCSR1 (TCSR3), these bits select the compare match B output level or the input capture input detected edge.

The function of TCORB1 (TCORB3) depends on the setting of bit 4 of TCSR1 (TCSR3). TCORB0 and TCORB2 function as compare match registers regardless of the setting of bit 4 of TCSR1 (TCSR3).

**ICE Bit in**

TCSR1 (TCSR3)	Bit 3 OIS3	Bit 2 OIS2	Description
0	0	0	No change when compare match B occurs (Initial value)
		1	0 is output when compare match B occurs
	1	0	1 is output when compare match B occurs
		1	Output is inverted when compare match B occurs (toggle output)
1	0	0	TCORB input capture on rising edge
		1	TCORB input capture on falling edge
	1	0	TCORB input capture on both rising and falling edges
		1	

- When the compare match register function is used, the timer output priority order is: toggle output > 1 output > 0 output.
- If compare match A and B occur simultaneously, the output changes in accordance with the higher-priority compare match.
- When bits OIS3, OIS2, OS1, and OS0 are all cleared to 0, timer output is disabled.

**Bits 1 and 0—Output Select A1 and A0 (OS1, OS0):** These bits select the compare match A output level.

<b>Bit 1 OS1</b>	<b>Bit 0 OS0</b>	<b>Description</b>
0	0	No change when compare match A occurs (Initial value)
	1	0 is output when compare match A occurs
1	0	1 is output when compare match A occurs
	1	Output is inverted when compare match A occurs (toggle output)

- When the compare match register function is used, the timer output priority order is: toggle output > 1 output > 0 output.
- If compare match A and B occur simultaneously, the output changes in accordance with the higher-priority compare match.
- When bits OIS3, OIS2, OS1, and OS0 are all cleared to 0, timer output is disabled.



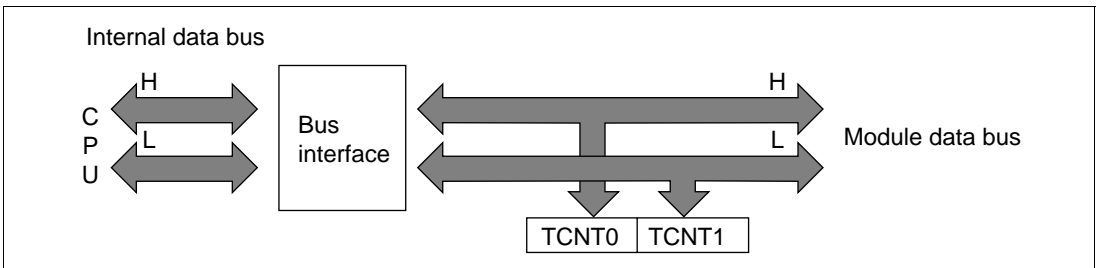
## 10.3 CPU Interface

### 10.3.1 8-Bit Registers

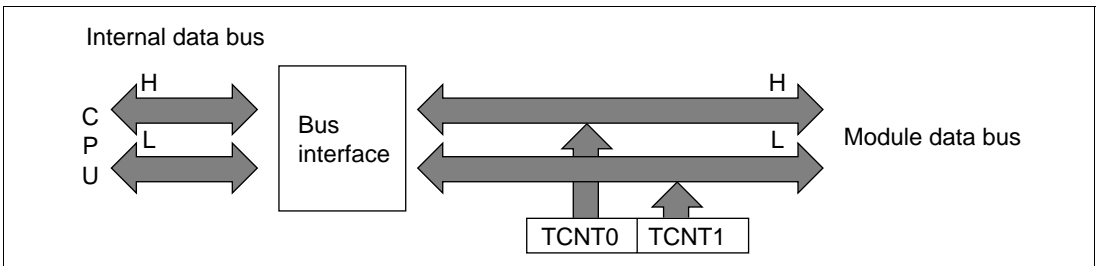
TCNT, TCORA, TCORB, TCR, and TCSR are 8-bit registers. These registers are connected to the CPU by an internal 16-bit data bus and can be read and written a word at a time or a byte at a time.

Figures 10.2 and 10.3 show the operation in word read and write accesses to TCNT.

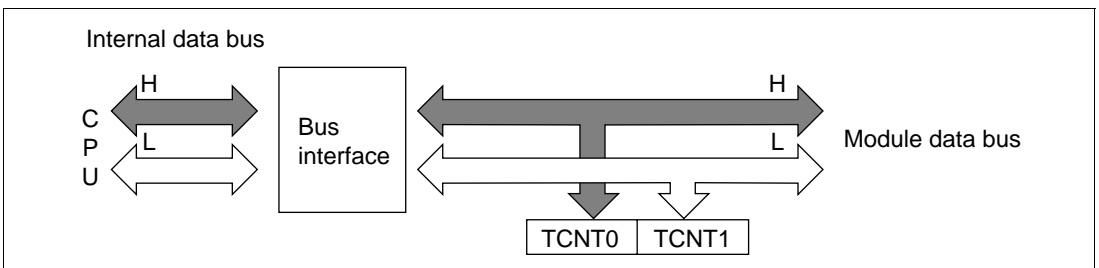
Figures 10.4 to 10.7 show the operation in byte read and write accesses to TCNT0 and TCNT1.



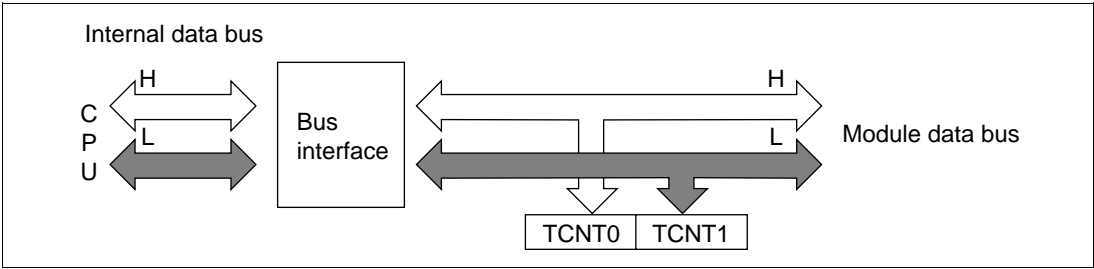
**Figure 10.2 TCNT Access Operation (CPU Writes to TCNT, Word)**



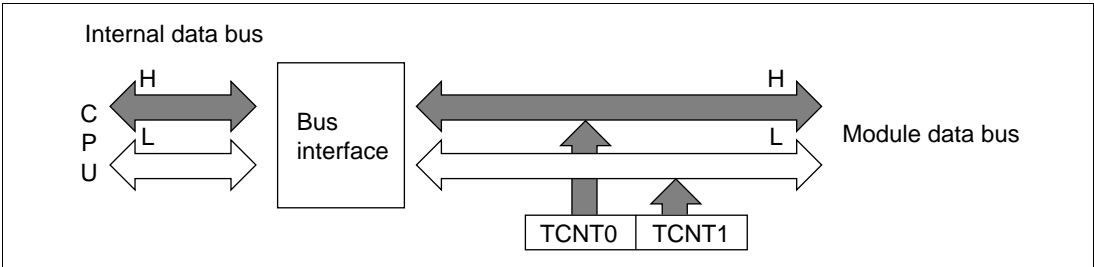
**Figure 10.3 TCNT Access Operation (CPU Reads TCNT, Word)**



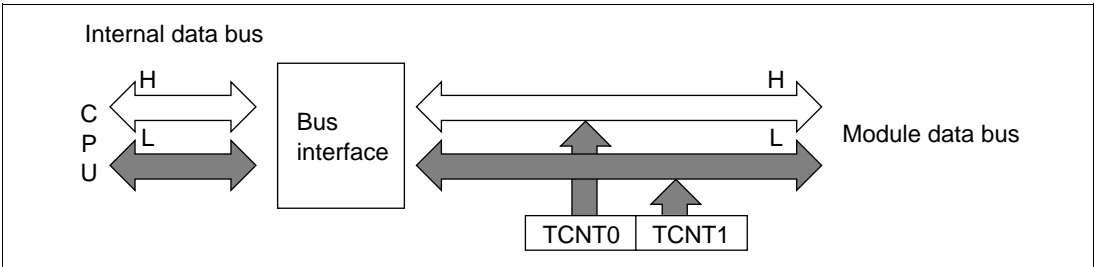
**Figure 10.4 TCNT Access Operation (CPU Writes to TCNT, Upper Byte)**



**Figure 10.5 TCNT Access Operation (CPU Writes to TCNT, Lower Byte)**



**Figure 10.6 TCNT Access Operation (CPU Reads TCNT, Upper Byte)**



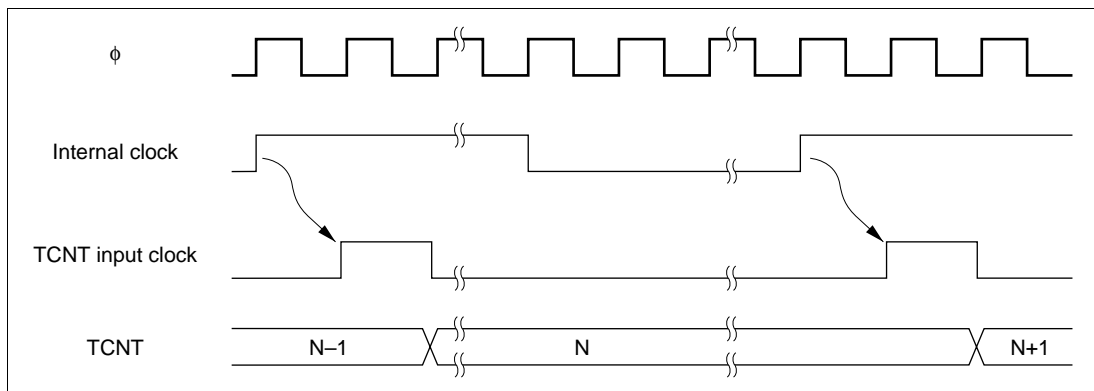
**Figure 10.7 TCNT Access Operation (CPU Reads TCNT, Lower Byte)**

## 10.4 Operation

### 10.4.1 TCNT Count Timing

TCNT is incremented by input clock pulses (either internal or external).

**Internal Clock:** Three different internal clock signals ( $\phi/8$ ,  $\phi/64$ , or  $\phi/8192$ ) divided from the system clock ( $\phi$ ) can be selected, by setting bits CKS2 to CKS0 in TCR. Figure 10.8 shows the count timing.



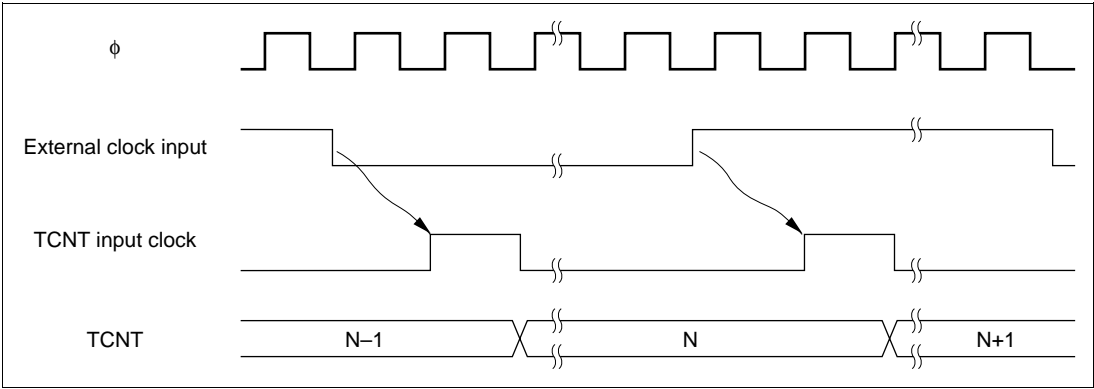
**Figure 10.8 Count Timing for Internal Clock Input**

**Note:** Even when the same internal clock is selected for both the 16- and 8-bit timers, they do not operate in the same manner because the count-up edge differs.

**External Clock:** Three incrementation methods can be selected by setting bits CKS2 to CKS0 in TCR: on the rising edge, the falling edge, and both rising and falling edges.

The pulse width of the external clock signal must be at least 1.5 serial clocks when a single edge is selected, and at least 2.5 system clocks when both edges are selected. Shorter pulses will not be counted correctly.

Figure 10.9 shows the timing for incrementation on both edges of the external clock signal.

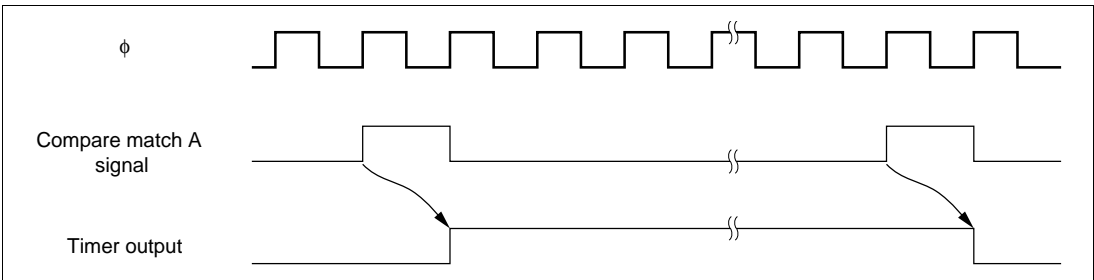


**Figure 10.9 Count Timing for External Clock Input (when Detecting the Both Edges)**

### 10.4.2 Compare Match Timing

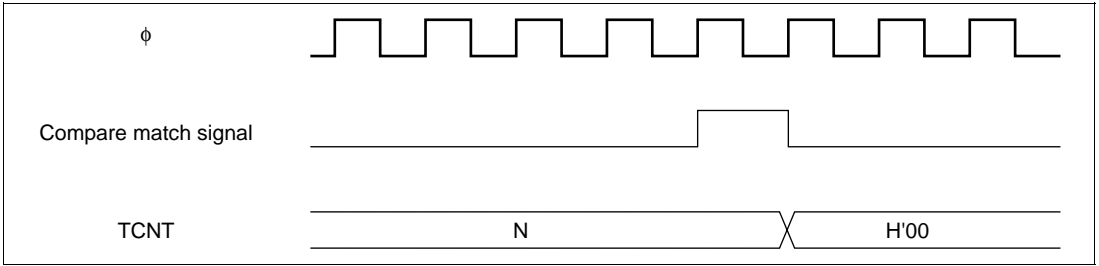
**Timer Output Timing:** When compare match A or B occurs, the timer output is as specified by the OIS3, OIS2, OS1, and OS0 bits in TCSR (unchanged, 0 output, 1 output, or toggle output).

Figure 10.10 shows the timing when the output is set to toggle on compare match A.



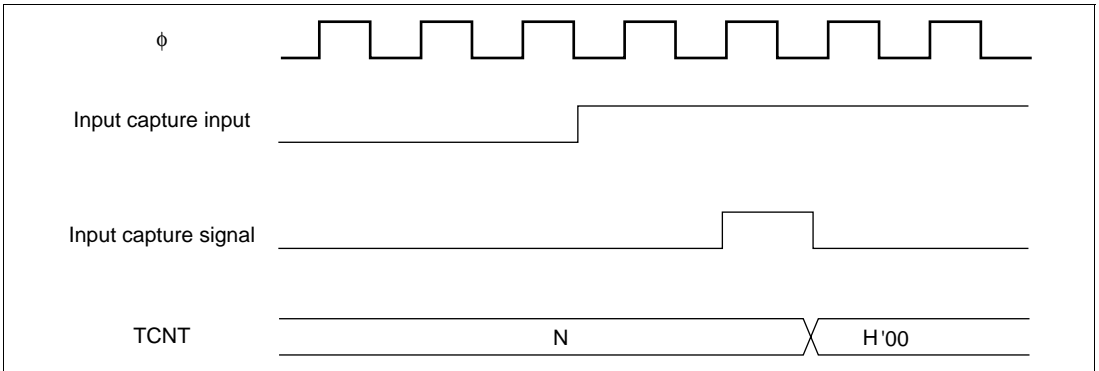
**Figure 10.10 Timing of Timer Output**

**Clear by Compare Match:** Depending on the setting of the CCLR1 and CCLR0 bits in TCR, TCNT can be cleared when compare match A or B occurs, Figure 10.11 shows the timing of this operation.



**Figure 10.11 Timing of Clear by Compare Match**

**Clear by Input Capture:** Depending on the setting of the CCLR1 and CCLR0 bits in TCR, TCNT can be cleared when input capture B occurs. Figure 10.12 shows the timing of this operation.



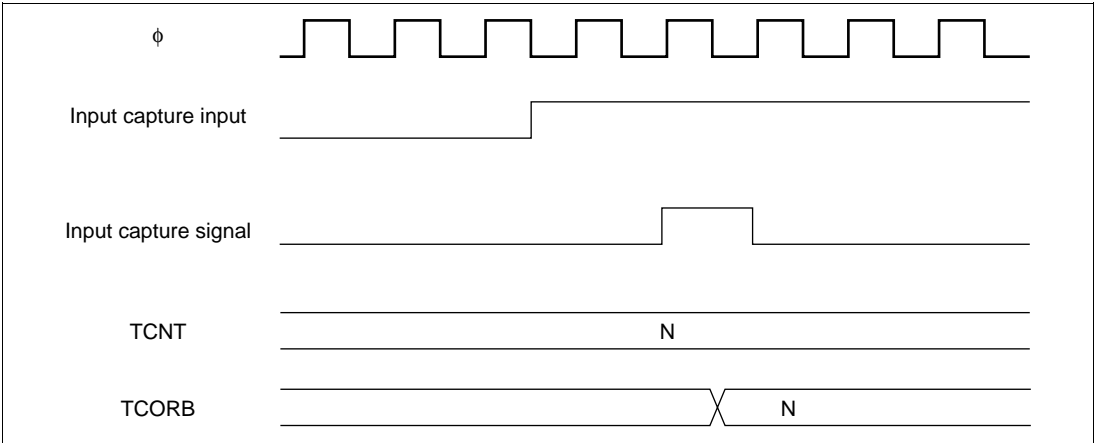
**Figure 10.12 Timing of Clear by Input Capture**

### 10.4.3 Input Capture Signal Timing

Input capture on the rising edge, falling edge, or both edges can be selected by settings in TCSR.

Figure 10.13 shows the timing when the rising edge is selected.

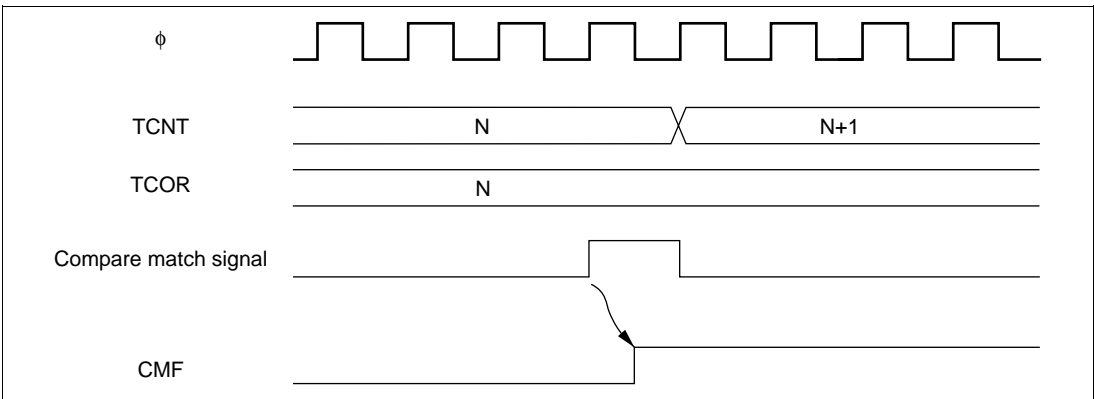
The pulse width of the input capture input signal must be at least 1.5 system clocks when a single edge is selected, and at least 2.5 system clocks when both edges are selected.



**Figure 10.13 Timing of Input Capture Input Signal**

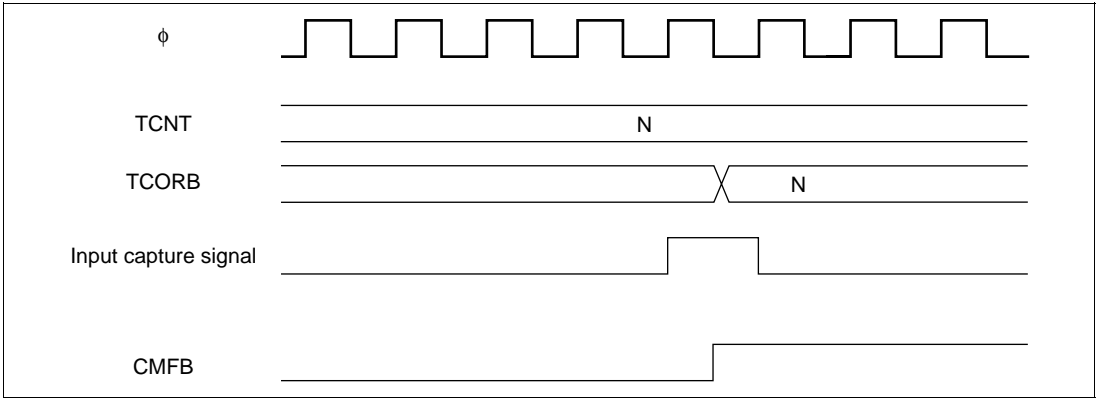
#### 10.4.4 Timing of Status Flag Setting

**Timing of CMFA/CMFB Flag Setting when Compare Match Occurs:** CMFA and CMFB in TCSR are set to 1 by the compare match signal output when the TCOR and TCNT values match. The compare match signal is generated in the last state of the match (when the matched TCNT count value is updated). Therefore, after the TCNT and TCOR values match, the compare match signal is not generated until an incrementing clock pulse is generated. Figure 10.14 shows the timing in this case.



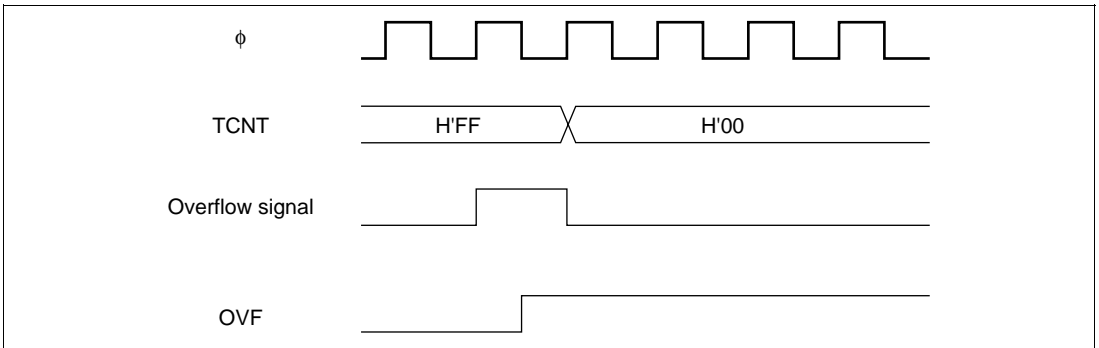
**Figure 10.14 CMF Flag Setting Timing when Compare Match Occurs**

**Timing of CMFB Flag Setting when Input Capture Occurs:** On generation of an input capture signal, the CMFB flag is set to 1 and at the same time the TCNT value is transferred to TCORB. Figure 10.15 shows the timing in this case.



**Figure 10.15 CMFB Flag Setting Timing when Input Capture Occurs**

**Timing of Overflow Flag (OVF) Setting:** The OVF flag in TCSR is set to 1 by the overflow signal generated when TCNT overflows (from H'FF to H'00). Figure 10.16 shows the timing in this case.



**Figure 10.16 Timing of OVF Setting**

#### 10.4.5 Operation with Cascaded Connection

If bits CKS2 to CKS0 are set to B'100 in either TCR0 or TCR1, the 8-bit timers of channels 0 and 1 are cascaded. With this configuration, the two timers can be used as a single 16-bit timer (16-bit count mode), or channel 0 8-bit timer compare matches can be counted in channel 1 (compare match count mode). In this case, the timer operates as below. Similarly, if bits CKS2 to CKS0 are set to B'100 in either TCR2 or TCR3, the 8-bit timers of channels 0 and 1 are cascaded. With this configuration, the two timers can be used as a single 16-bit timer (16-bit count mode), or channel 2 8-bit timer compare matches can be counted in channel 3 (compare match count mode). Timer operation in these cases is described below.

## 16-Bit Count Mode

- Channels 0 and 1:

When bits CKS2 to CKS0 are set to B'100 in TCR0, the timer functions as a single 16-bit timer with channel 0 occupying the upper 8 bits and channel 1 occupying the lower 8 bits.

— Setting when Compare Match Occurs

- The CMF flag is set to 1 in TCR0 when a 16-bit compare match occurs.
- The CMF flag is set to 1 in TCR1 when a lower 8-bit compare match occurs.
- TMO<sub>0</sub> pin output control by bits OIS3, OIS2, OS1, and OS0 in TCSR0 is in accordance with the 16-bit compare match conditions.
- TMIO<sub>1</sub> pin output control by bits OIS3, OIS2, OS1, and OS0 in TCSR1 is in accordance with the lower 8-bit compare match conditions.

— Setting when Input Capture Occurs

- The CMFB flag is set to 1 in TCR0 and TCR1 when the ICE bit is 1 in TCSR1 and input capture occurs.
- TMIO<sub>1</sub> pin input capture input signal edge detection is selected by bits OIS3 and OIS2 in TCSR0.

— Counter Clear Specification

- If counter clear on compare match or input capture has been selected by the CCLR1 and CCLR0 bits in TCR0, the 16-bit counter (both TCNT0 and TCNT1) is cleared.
- The settings of the CCLR1 and CCLR0 bits in TCR1 are ignored. The lower 8 bits cannot be cleared independently.

— OVF Flag Operation

- The OVF flag is set to 1 in TCSR0 when the 16-bit counter (TCNT0 and TCNT1) overflows (from H'FFFF to H'0000).
- The OVF flag is set to 1 in TCSR1 when the 8-bit counter (TCNT1) overflows (from H'FF to H'00).

- Channels 2 and 3:

When bits CKS2 to CKS0 are set to B'100 in TCR2, the timer functions as a single 16-bit timer with channel 2 occupying the upper 8 bits and channel 3 occupying the lower 8 bits.

— Setting when Compare Match Occurs

- The CMF flag is set to 1 in TCR2 when a 16-bit compare match occurs.
- The CMF flag is set to 1 in TCR3 when a lower 8-bit compare match occurs.
- TMO<sub>2</sub> pin output control by bits OIS3, OIS2, OS1, and OS0 in TCSR2 is in accordance with the 16-bit compare match conditions.
- TMIO<sub>3</sub> pin output control by bits OIS3, OIS2, OS1, and OS0 in TCSR3 is in accordance with the lower 8-bit compare match conditions.



— Setting when Input Capture Occurs

- The CMFB flag is set to 1 in TCR2 and TCR3 when the ICE bit is 1 in TCSR3 and input capture occurs.
- TMIO<sub>3</sub> pin input capture input signal edge detection is selected by bits OIS3 and OIS2 in TCSR2.

— Counter Clear Specification

- If counter clear on compare match has been selected by the CCLR1 and CCLR0 bits in TCR2, the 16-bit counter (both TCNT2 and TCNT3) is cleared.
- The settings of the CCLR1 and CCLR0 bits in TCR3 are ignored. The lower 8 bits cannot be cleared independently.

— OVF Flag Operation

- The OVF flag is set to 1 in TCSR2 when the 16-bit counter (TCNT2 and TCNT3) overflows (from H'FFFF to H'0000).
- The OVF flag is set to 1 in TCSR3 when the 16-bit counter (TCNT3) overflows (from H'FF to H'00).

## Compare Match Count Mode

- Channels 0 and 1:

When bits CKS2 to CKS0 are set to B'100 in TCR1, TCNT1 counts channel 0 compare match A events.

Channels 0 and 1 are controlled independently. CMF flag setting, interrupt generation, TMO pin output, counter clearing, and so on, is in accordance with the settings for each channel.

- Channels 2 and 3:

When bits CKS2 to CKS0 are set to B'100 in TCR3, TCNT3 counts channel 2 compare match A events.

Channels 2 and 3 are controlled independently. CMF flag setting, interrupt generation, TMO pin output, counter clearing, and so on, is in accordance with the settings for each channel.

## Caution

Do not set 16-bit count mode and compare match count mode simultaneously within the same group, as the TCNT input clock will not be generated and the counters will not operate.

### 10.4.6 Input Capture Setting

The TCNT value can be transferred to TCORB on detection of an input edge on the input capture/output compare pin (TMIO<sub>1</sub> or TMIO<sub>3</sub>). Rising edge, falling edge, or both edge detection can be selected. In 16-bit count mode, 16-bit input capture can be used.

## Setting Input Capture Operation in 8-Bit Timer Mode (Normal Operation)

- Channel 1:
  - Set TCORB1 as an 8-bit input capture register with the ICE bit in TCSR1.
  - Select rising edge, falling edge, or both edges as the input edge(s) for the input capture signal (TMIO<sub>1</sub>) with bits OIS3 and OIS2 in TCSR1.
  - Select the input clock with bits CKS2 to CKS0 in TCR1, and start the TCNT count.
- Channel 3:
  - Set TCORB3 as an 8-bit input capture register with the ICE bit in TCSR3.
  - Select rising edge, falling edge, or both edges as the input edge(s) for the input capture signal (TMIO<sub>3</sub>) with bits OIS3 and OIS2 in TCSR3.
  - Select the input clock with bits CKS2 to CKS0 in TCR3, and start the TCNT count.

## Setting Input Capture Operation in 16-Bit Count Mode

- Channels 0 and 1:
  - In 16-bit count mode, TCORB0 and TCORB1 function as a 16-bit input capture register when the ICE bit is set to 1 in TCSR1.
  - Select rising edge, falling edge, or both edges as the input edge(s) for the input capture signal (TMIO<sub>1</sub>) with bits OIS3 and OIS2 in TCSR0. (In 16-bit count mode, the settings of bits OIS3 and OIS2 in TCSR1 are ignored.)
  - Select the input clock with bits CKS2 to CKS0 in TCR1, and start the TCNT count.
- Channels 2 and 3:
  - In 16-bit count mode, TCORB2 and TCORB3 function as a 16-bit input capture register when the ICE bit is set to 1 in TCSR3.
  - Select rising edge, falling edge, or both edges as the input edge(s) for the input capture signal (TMIO<sub>3</sub>) with bits OIS3 and OIS2 in TCSR2. (In 16-bit count mode, the settings of bits OIS3 and OIS2 in TCSR3 are ignored.)
  - Select the input clock with bits CKS2 to CKS0 in TCR3, and start the TCNT count.

## 10.5 Interrupts

### 10.5.1 Interrupt Sources

The 8-bit timer unit can generate three types of interrupt: compare match A and B (CMIA and CMIB) and overflow (OVI). Table 10.3 shows the interrupt sources and their priority order. Each interrupt source is enabled or disabled by the corresponding interrupt enable bit in TCR. A separate interrupt request signal is sent to the interrupt controller by each interrupt source.

**Table 10.3 Types of 8-Bit Timer Interrupt Sources and Priority Order**

Interrupt Source	Description	Priority
CMIA	Interrupt by CMFA	High
CMIB	Interrupt by CMFB	↑
TOVI	Interrupt by OVF	Low

For compare match interrupts CMIA1/CMIB1 and CMIA3/CMIB3 and the overflow interrupts (TOVI0/TOVI1 and TOVI2/TOVI3), one vector is shared by two interrupts.

Table 10.4 lists the interrupt sources.

**Table 10.4 8-Bit Timer Interrupt Sources**

Channel	Interrupt Source	Description
0	CMIA0	TCORA0 compare match
	CMIB0	TCORB0 compare match/input capture
1	CMIA1/CMIB1	TCORA1 compare match, or TCORB1 compare match/input capture
0, 1	TOVI0/TOVI1	Counter 0 or counter 1 overflow
2	CMIA2	TCORA2 compare match
	CMIB2	TCORB2 compare match/input capture
3	CMIA3/CMIB3	TCORA3 compare match, or TCORB3 compare match/input capture
2,3	TOVI2/TOVI3	Counter 2 or counter 3 overflow

## 10.5.2 A/D Converter Activation

The A/D converter can only be activated by channel 0 compare match A.

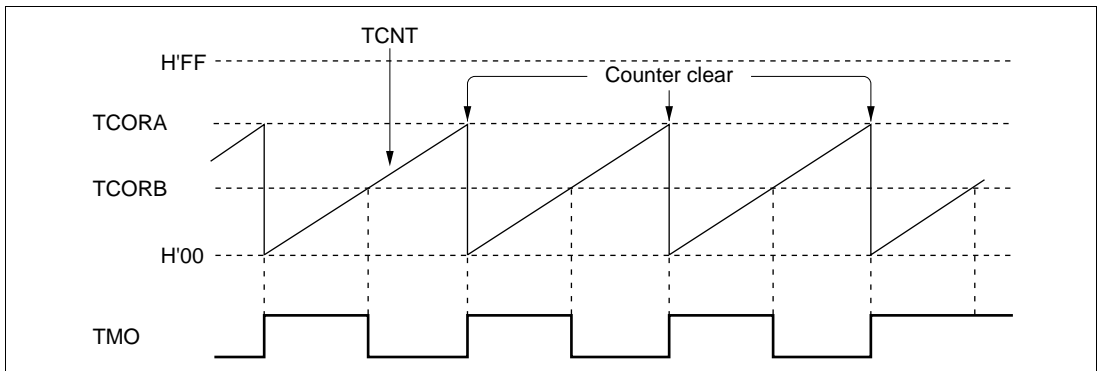
If the ADTE bit setting is 1 when the CMFA flag in TCSR0 is set to 1 by generation of channel 0 compare match A, an A/D conversion start request will be issued to the A/D converter. If the TRGE bit in ADCR is 1 at this time, the A/D converter will be started. If the ADTE bit in TCSR0 is 1, the A/D converter external trigger input ( $\overline{\text{ADTRG}}$ ) is disabled.

## 10.6 8-Bit Timer Application Example

Figure 10.17 shows how the 8-bit timer module can be used to output pulses with any desired duty cycle. The settings for this example are as follows:

- Clear the CCLR1 bit to 0 and set the CCLR0 bit to 1 in TCR so that TCNT is cleared by a TCORA compare match.
- Set bits OIS3, OIS2, OS1, and OS0 to B'0110 in TCSR so that 1 is output on a TCORA compare match and 0 is output on a TCORB compare match.

The above settings enable a waveform with the cycle determined by TCORA and the pulse width detected by TCORB to be output without software intervention.



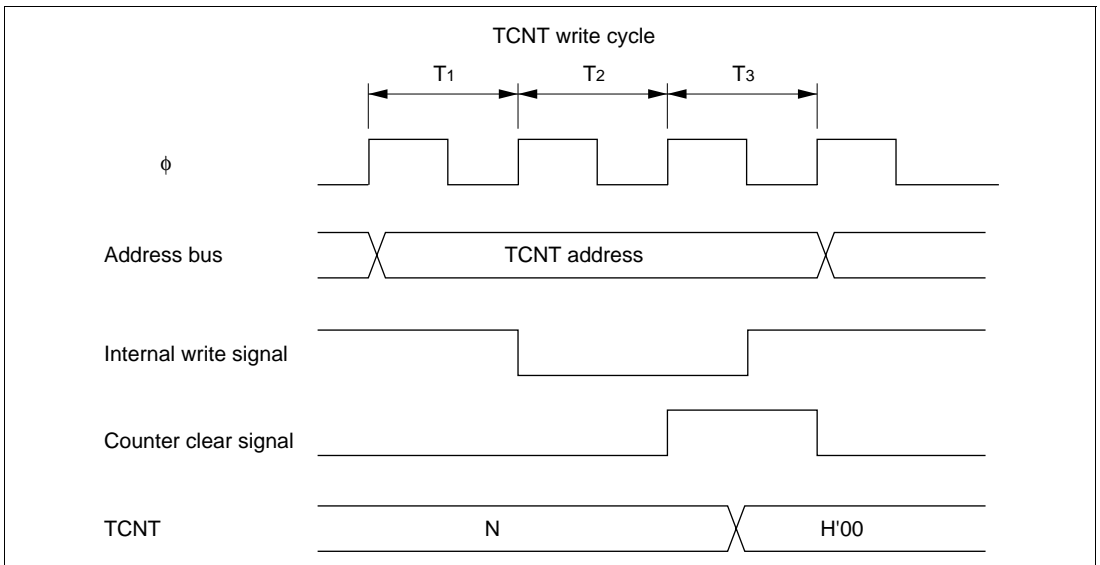
**Figure 10.17 Example of Pulse Output**

## 10.7 Usage Notes

Note that the following kinds of contention can occur in 8-bit timer operation.

### 10.7.1 Contention between TCNT Write and Clear

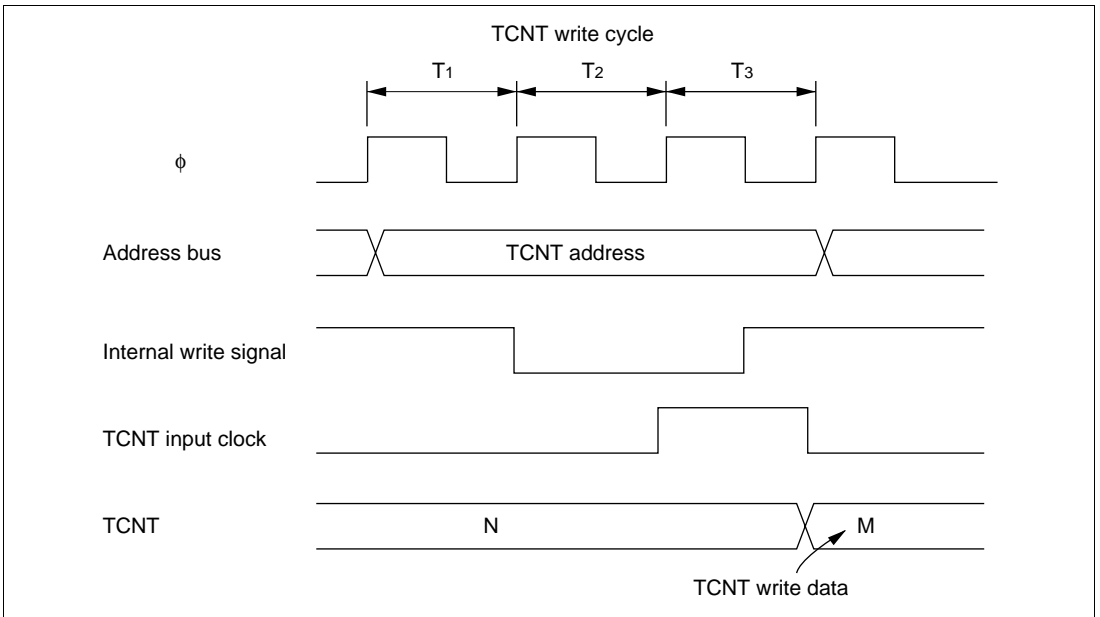
If a timer counter clear signal occurs in the  $T_3$  state of a TCNT write cycle, clearing of the counter takes priority and the write is not performed. Figure 10.18 shows the timing in this case.



**Figure 10.18** Contention between TCNT Write and Clear

## 10.7.2 Contention between TCNT Write and Increment

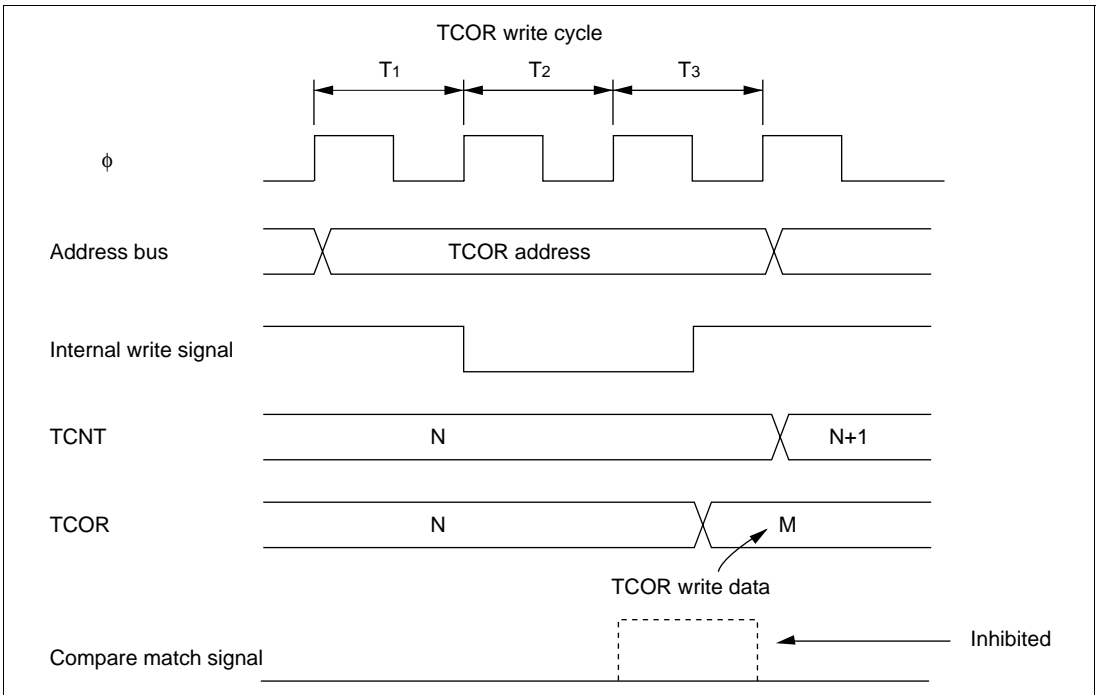
If an increment pulse occurs in the  $T_3$  state of a TCNT write cycle, writing takes priority and TCNT is not incremented. Figure 10.19 shows the timing in this case.



**Figure 10.19** Contention between TCNT Write and Increment

### 10.7.3 Contention between TCOR Write and Compare Match

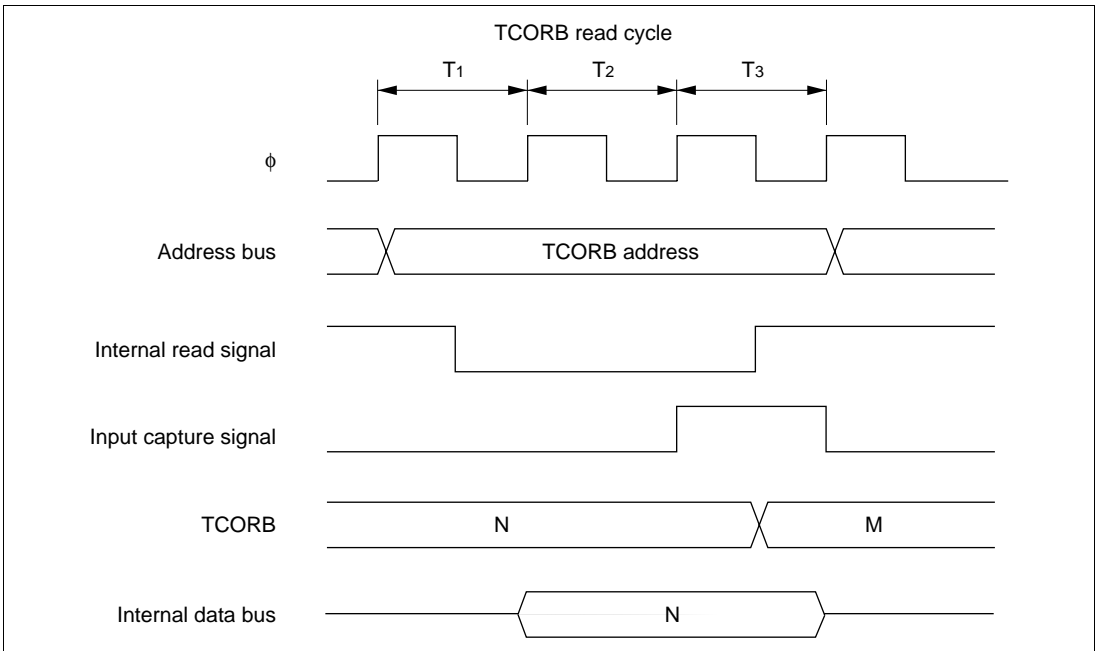
If a compare match occurs in the  $T_3$  state of a TCOR write cycle, writing takes priority and the compare match signal is inhibited. Figure 10.20 shows the timing in this case.



**Figure 10.20** Contention between TCOR Write and Compare Match

### 10.7.4 Contention between TCOR Read and Input Capture

If an input capture signal occurs in the  $T_3$  state of a TCOR read cycle, the value before input capture is read. Figure 10.21 shows the timing in this case.

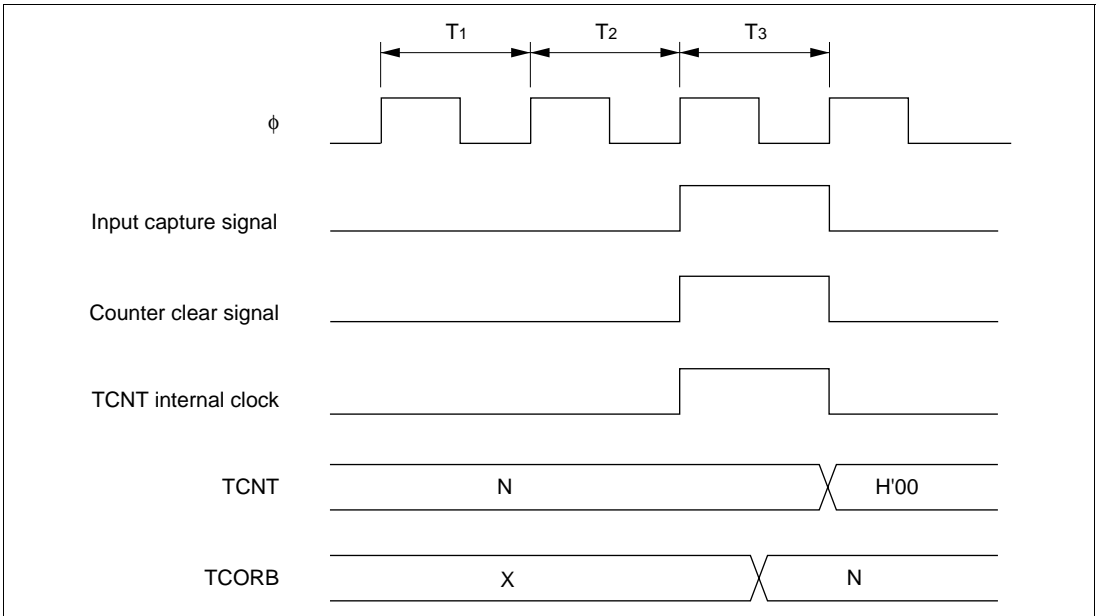


**Figure 10.21** Contention between TCOR Read and Input Capture



## 10.7.5 Contention between Counter Clearing by Input Capture and Counter Increment

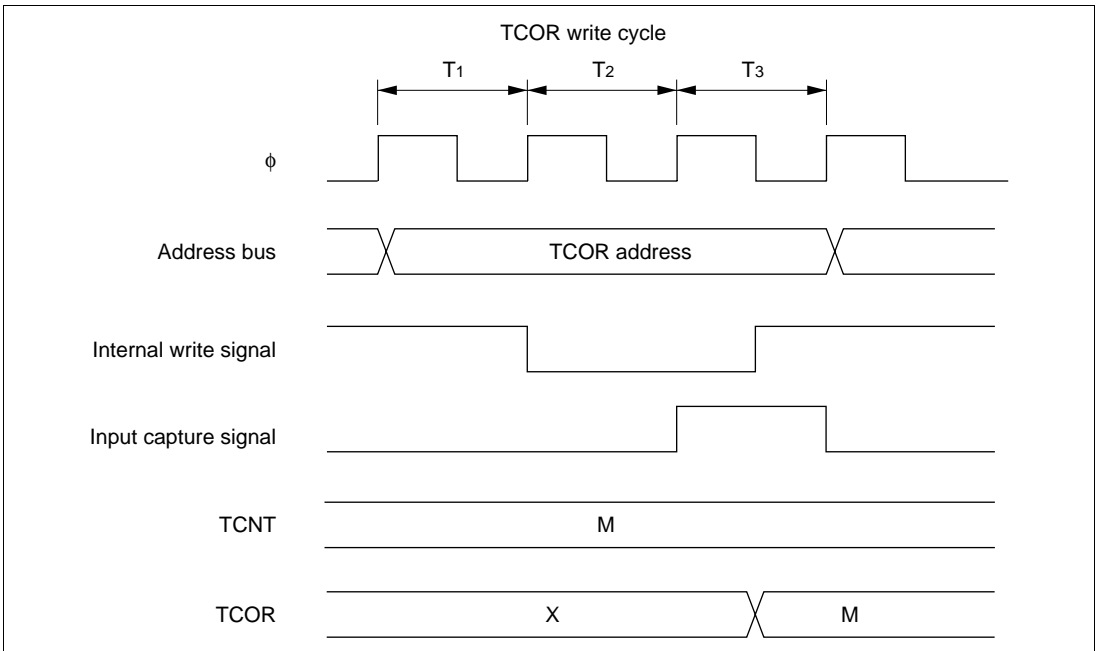
If an input capture signal and counter increment signal occur simultaneously, counter clearing by the input capture signal takes priority and the counter is not incremented. The value before the counter is cleared is transferred to TCORB. Figure 10.22 shows the timing in this case.



**Figure 10.22 Contention between Counter Clearing by Input Capture and Counter Increment**

## 10.7.6 Contention between TCOR Write and Input Capture

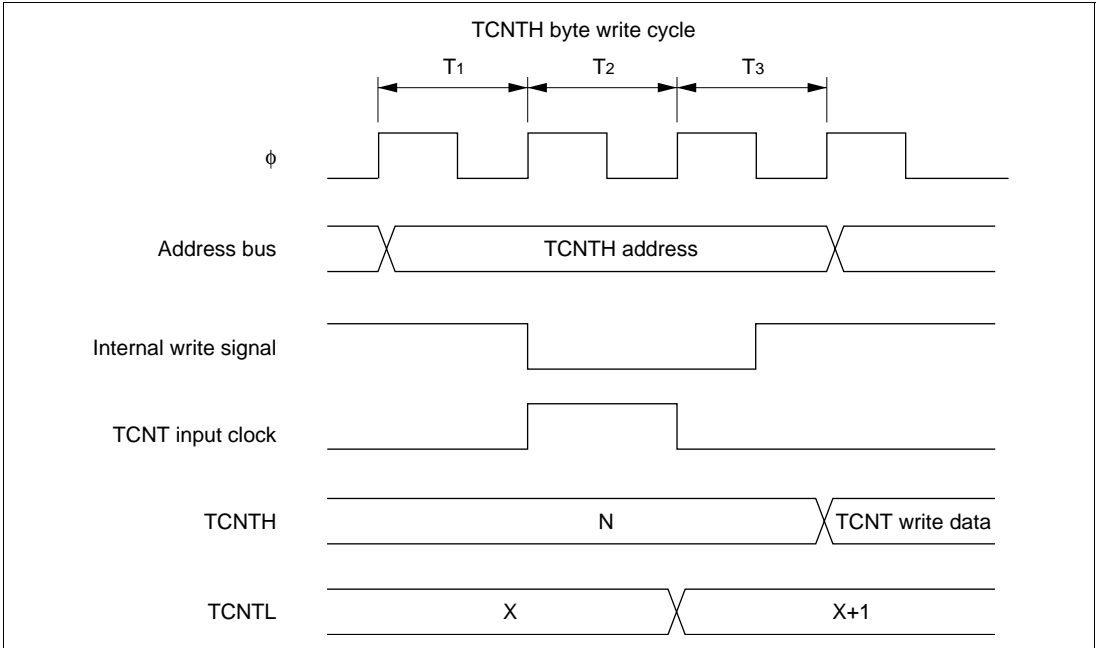
If an input capture signal occurs in the  $T_3$  state of a TCOR write cycle, input capture takes priority and the write to TCOR is not performed. Figure 10.23 shows the timing in this case.



**Figure 10.23 Contention between TCOR Write and Input Capture**

### 10.7.7 Contention between TCNT Byte Write and Increment in 16-Bit Count Mode (Cascaded Connection)

If an increment pulse occurs in the  $T_2$  or  $T_3$  state of a TCNT byte write cycle in 16-bit count mode, writing takes priority and TCNT is not incremented. The TCNT byte that was not written retains its previous value. Figure 10.24 shows the timing when an increment pulse occurs in the  $T_2$  state of a byte write to TCNTH.



**Figure 10.24** Contention between TCNT Byte Write and Increment in 16-Bit Count Mode

## 10.7.8 Contention between Compare Matches A and B

If compare matches A and B occur at the same time, the 8-bit timer operates according to the relative priority of the output states set for compare match A and compare match B, as shown in Table 10.5.

**Table 10.5 Timer Output Priority Order**

Output Setting	Priority
Toggle output	High
1 output	↑
0 output	
No change	Low

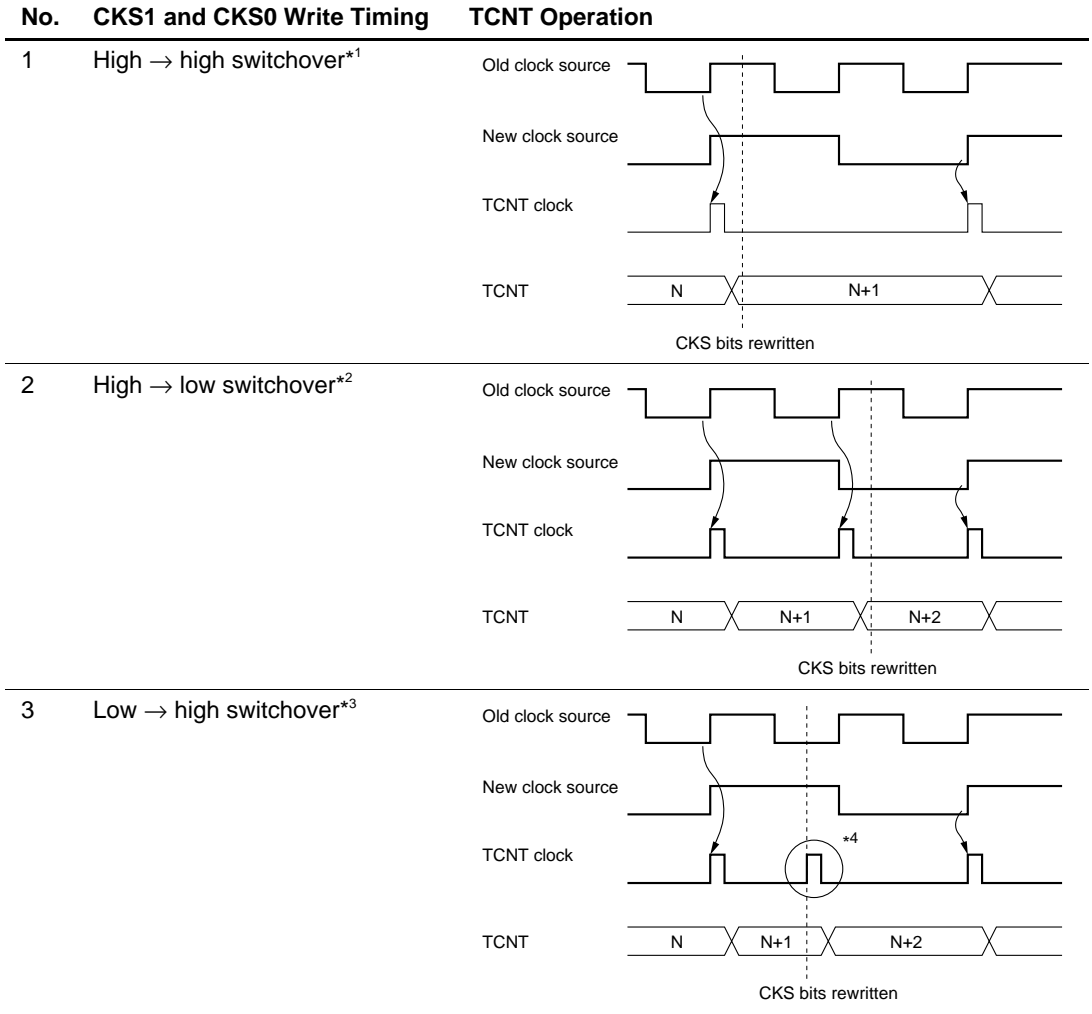
## 10.7.9 TCNT Operation at Internal Clock Source Switchover

Switching internal clock sources may cause TCNT to increment, depending on the switchover timing. Table 10.6 shows the relation between the time of the switchover (by writing to bits CKS1 and CKS0) and the operation of TCNT.

The TCNT input clock is generated from the internal clock source by detecting the rising edge of the internal clock. If a switchover is made from a Low clock source to a High clock source, as in case No. 3 in Table 10.6, the switchover will be regarded as a falling edge, a TCNT clock pulse will be generated, and TCNT will be incremented.

TCNT may also be incremented when switching between internal and external clocks.

**Table 10.6 Internal Clock Switchover and TCNT Operation**



**Table 10.6 Internal Clock Switchover and TCNT Operation (cont)**

No.	CKS1 and CKS0 Write Timing	TCNT Operation
4	Low → low switchover	<p>The diagram illustrates the timing for a low-to-low clock switchover. It shows four signals over time:         <ul style="list-style-type: none"> <li><b>Old clock source:</b> High during the first two TCNT clock cycles (N and N+1), then transitions to low.</li> <li><b>New clock source:</b> Low during the first two TCNT clock cycles, then transitions to high.</li> <li><b>TCNT clock:</b> A square wave with three rising edges corresponding to TCNT values N, N+1, and N+2.</li> <li><b>TCNT:</b> A counter that increments from N to N+1 at the first rising edge, and from N+1 to N+2 at the second rising edge. A vertical dashed line labeled "CKS bits rewritten" is placed between the second and third rising edges of the TCNT clock.</li> </ul> </p>

- Notes:
1. Including switchovers from a high clock source to the halted state, and from the halted state to a high clock source.
  2. Including switchover from the halted state to a low clock source.
  3. Including switchover from a low clock source to the halted state.
  4. The switchover is regarded as a rising edge, causing TCNT to increment.

# Section 11 Programmable Timing Pattern Controller (TPC)

## 11.1 Overview

The H8/3067 Series has a built-in programmable timing pattern controller (TPC) that provides pulse outputs by using the 16-bit timer as a time base. The TPC pulse outputs are divided into 4-bit groups (group 3 to group 0) that can operate simultaneously and independently.

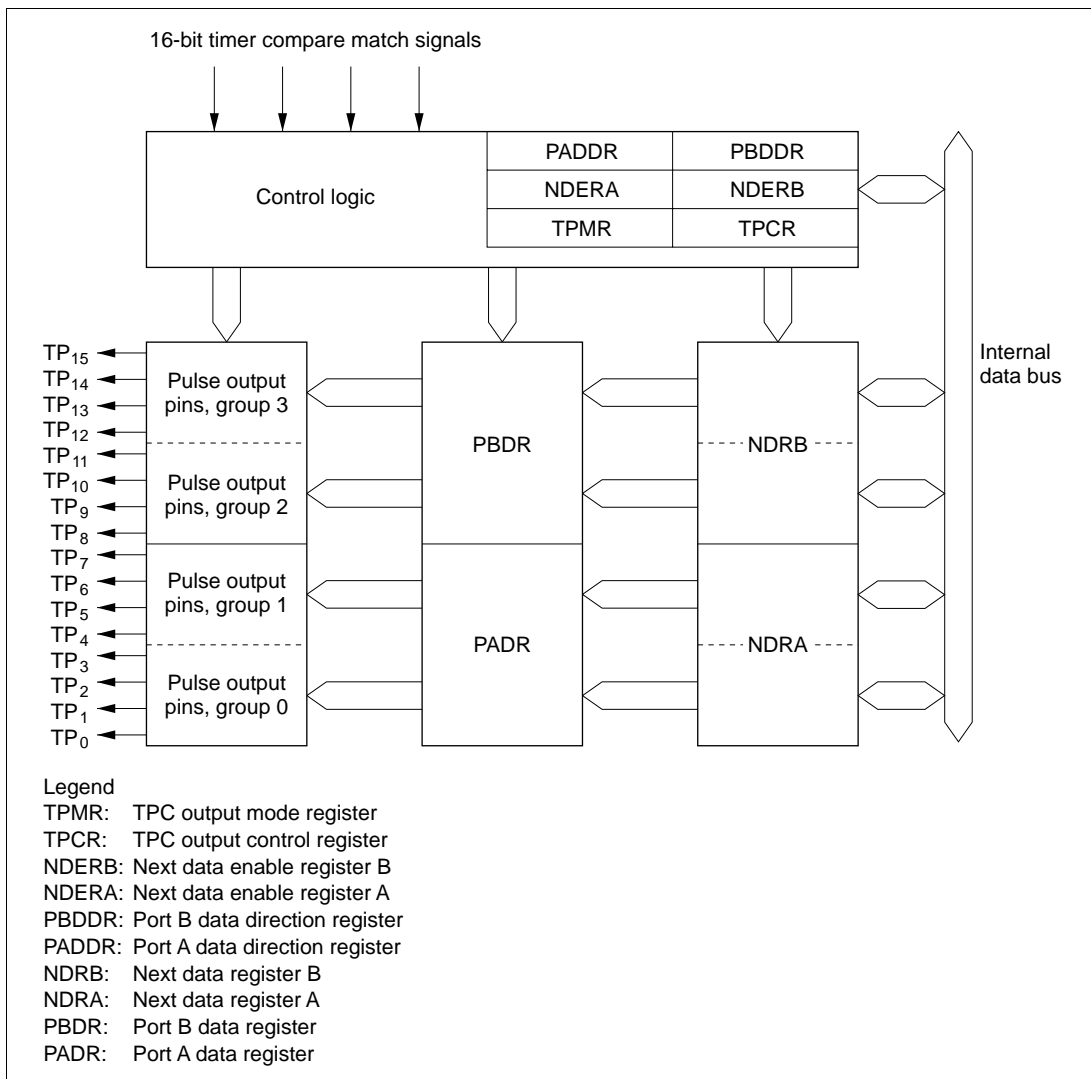
### 11.1.1 Features

TPC features are listed below.

- 16-bit output data  
Maximum 16-bit data can be output. TPC output can be enabled on a bit-by-bit basis.
- Four output groups  
Output trigger signals can be selected in 4-bit groups to provide up to four different 4-bit outputs.
- Selectable output trigger signals  
Output trigger signals can be selected for each group from the compare match signals of three 16-bit timer channels.
- Non-overlap mode  
A non-overlap margin can be provided between pulse outputs.
- Can operate together with the DMA controller (DMAC)  
The compare-match signals selected as trigger signals can activate the DMAC for sequential output of data without CPU intervention.

## 11.1.2 Block Diagram

Figure 11.1 shows a block diagram of the TPC.



**Figure 11.1 TPC Block Diagram**



### 11.1.3 TPC Pins

Table 11.1 summarizes the TPC output pins.

**Table 11.1 TPC Pins**

<b>Name</b>	<b>Symbol</b>	<b>I/O</b>	<b>Function</b>
TPC output 0	TP <sub>0</sub>	Output	Group 0 pulse output
TPC output 1	TP <sub>1</sub>	Output	
TPC output 2	TP <sub>2</sub>	Output	
TPC output 3	TP <sub>3</sub>	Output	Group 1 pulse output
TPC output 4	TP <sub>4</sub>	Output	
TPC output 5	TP <sub>5</sub>	Output	
TPC output 6	TP <sub>6</sub>	Output	
TPC output 7	TP <sub>7</sub>	Output	Group 2 pulse output
TPC output 8	TP <sub>8</sub>	Output	
TPC output 9	TP <sub>9</sub>	Output	
TPC output 10	TP <sub>10</sub>	Output	Group 3 pulse output
TPC output 11	TP <sub>11</sub>	Output	
TPC output 12	TP <sub>12</sub>	Output	
TPC output 13	TP <sub>13</sub>	Output	
TPC output 14	TP <sub>14</sub>	Output	
TPC output 15	TP <sub>15</sub>	Output	

## 11.1.4 Registers

Table 11.2 summarizes the TPC registers.

**Table 11.2 TPC Registers**

Address* <sup>1</sup>	Name	Abbreviation	R/W	Function
H'EE009	Port A data direction register	PADDR	W	H'00
H'FFFD9	Port A data register	PADR	R/(W)* <sup>2</sup>	H'00
H'EE00A	Port B data direction register	PBDDR	W	H'00
H'FFFDA	Port B data register	PBDR	R/(W)* <sup>2</sup>	H'00
H'FFFA0	TPC output mode register	TPMR	R/W	H'F0
H'FFFA1	TPC output control register	TPCR	R/W	H'FF
H'FFFA2	Next data enable register B	NDERB	R/W	H'00
H'FFFA3	Next data enable register A	NDERA	R/W	H'00
H'FFFA5/ H'FFFA7* <sup>3</sup>	Next data register A	NDRA	R/W	H'00
H'FFFA4/ H'FFFA6* <sup>3</sup>	Next data register B	NDRB	R/W	H'00

Notes: 1. Lower 20 bits of the address in advanced mode.

2. Bits used for TPC output cannot be written.

3. The NDRA address is H'FFFA5 when the same output trigger is selected for TPC output groups 0 and 1 by settings in TPCR. When the output triggers are different, the NDRA address is H'FFFA7 for group 0 and H'FFFA5 for group 1. Similarly, the address of NDRB is H'FFFA4 when the same output trigger is selected for TPC output groups 2 and 3 by settings in TPCR. When the output triggers are different, the NDRB address is H'FFFA6 for group 2 and H'FFFA4 for group 3.

## 11.2 Register Descriptions

### 11.2.1 Port A Data Direction Register (PADDR)

PADDR is an 8-bit write-only register that selects input or output for each pin in port A.

Bit	7	6	5	4	3	2	1	0
	PA <sub>7</sub> DDR	PA <sub>6</sub> DDR	PA <sub>5</sub> DDR	PA <sub>4</sub> DDR	PA <sub>3</sub> DDR	PA <sub>2</sub> DDR	PA <sub>1</sub> DDR	PA <sub>0</sub> DDR
Initial value	0	0	0	0	0	0	0	0
Read/Write	W	W	W	W	W	W	W	W

#### Port A data direction 7 to 0

These bits select input or output for port A pins

Port A is multiplexed with pins TP<sub>7</sub> to TP<sub>0</sub>. Bits corresponding to pins used for TPC output must be set to 1. For further information about PADDR, see section 8.11, Port A.

### 11.2.2 Port A Data Register (PADR)

PADR is an 8-bit readable/writable register that stores TPC output data for groups 0 and 1, when these TPC output groups are used.

Bit	7	6	5	4	3	2	1	0
	PA <sub>7</sub>	PA <sub>6</sub>	PA <sub>5</sub>	PA <sub>4</sub>	PA <sub>3</sub>	PA <sub>2</sub>	PA <sub>1</sub>	PA <sub>0</sub>
Initial value	0	0	0	0	0	0	0	0
Read/Write	R/(W)*	R/(W)*	R/(W)*	R/(W)*	R/(W)*	R/(W)*	R/(W)*	R/(W)*

#### Port A data 7 to 0

These bits store output data for TPC output groups 0 and 1

Note: \* Bits selected for TPC output by NDERA settings become read-only bits.

For further information about PADR, see section 8.11, Port A.

### 11.2.3 Port B Data Direction Register (PBDDR)

PBDDR is an 8-bit write-only register that selects input or output for each pin in port B.

Bit	7	6	5	4	3	2	1	0
	PB <sub>7</sub> DDR	PB <sub>6</sub> DDR	PB <sub>5</sub> DDR	PB <sub>4</sub> DDR	PB <sub>3</sub> DDR	PB <sub>2</sub> DDR	PB <sub>1</sub> DDR	PB <sub>0</sub> DDR
Initial value	0	0	0	0	0	0	0	0
Read/Write	W	W	W	W	W	W	W	W

#### Port B direction 7 to 0

These bits select input or output for port B pins

Port B is multiplexed with pins TP<sub>15</sub> to TP<sub>8</sub>. Bits corresponding to pins used for TPC output must be set to 1. For further information about PBDDR, see section 8.12, Port B.

### 11.2.4 Port B Data Register (PBDR)

PBDR is an 8-bit readable/writable register that stores TPC output data for groups 2 and 3, when these TPC output groups are used.

Bit	7	6	5	4	3	2	1	0
	PB <sub>7</sub>	PB <sub>6</sub>	PB <sub>5</sub>	PB <sub>4</sub>	PB <sub>3</sub>	PB <sub>2</sub>	PB <sub>1</sub>	PB <sub>0</sub>
Initial value	0	0	0	0	0	0	0	0
Read/Write	R/(W)*	R/(W)*	R/(W)*	R/(W)*	R/(W)*	R/(W)*	R/(W)*	R/(W)*

#### Port B data 7 to 0

These bits store output data for TPC output groups 2 and 3

Note: \* Bits selected for TPC output by NDERB settings become read-only bits.

For further information about PBDR, see section 8.12, Port B.

## 11.2.5 Next Data Register A (NDRA)

NDRA is an 8-bit readable/writable register that stores the next output data for TPC output groups 1 and 0 (pins TP<sub>7</sub> to TP<sub>0</sub>). During TPC output, when an 16-bit timer compare match event specified in TPCR occurs, NDRA contents are transferred to the corresponding bits in PADR. The address of NDRA differs depending on whether TPC output groups 0 and 1 have the same output trigger or different output triggers.

NDRA is initialized to H'00 by a reset and in hardware standby mode. It is not initialized in software standby mode.

**Same Trigger for TPC Output Groups 0 and 1:** If TPC output groups 0 and 1 are triggered by the same compare match event, the NDRA address is H'FFFA5. The upper 4 bits belong to group 1 and the lower 4 bits to group 0. Address H'FFFA7 consists entirely of reserved bits that cannot be modified and always read 1.

Address H'FFFA5

Bit	7	6	5	4	3	2	1	0
	NDR7	NDR6	NDR5	NDR4	NDR3	NDR2	NDR1	NDR0
Initial value	0	0	0	0	0	0	0	0
Read/Write	R/W	R/W	R/W	R/W	R/W	R/W	R/W	R/W

**Next data 7 to 4**  
These bits store the next output data for TPC output group 1

**Next data 3 to 0**  
These bits store the next output data for TPC output group 0

Address H'FFFA7

Bit	7	6	5	4	3	2	1	0
	—	—	—	—	—	—	—	—
Initial value	1	1	1	1	1	1	1	1
Read/Write	—	—	—	—	—	—	—	—

**Reserved bits**

**Different Triggers for TPC Output Groups 0 and 1:** If TPC output groups 0 and 1 are triggered by different compare match events, the address of the upper 4 bits of NDRA (group 1) is H'FFFA5 and the address of the lower 4 bits (group 0) is H'FFFA7. Bits 3 to 0 of address H'FFFA5 and bits 7 to 4 of address H'FFFA7 are reserved bits that cannot be modified and always read 1.

Address H'FFFA5

Bit	7	6	5	4	3	2	1	0
	NDR7	NDR6	NDR5	NDR4	—	—	—	—
Initial value	0	0	0	0	1	1	1	1
Read/Write	R/W	R/W	R/W	R/W	—	—	—	—

**Next data 7 to 4**  
These bits store the next output data for TPC output group 1
**Reserved bits**

Address H'FFFA7

Bit	7	6	5	4	3	2	1	0
	—	—	—	—	NDR3	NDR2	NDR1	NDR0
Initial value	1	1	1	1	0	0	0	0
Read/Write	—	—	—	—	R/W	R/W	R/W	R/W

**Reserved bits**
**Next data 3 to 0**  
These bits store the next output data for TPC output group 0

## 11.2.6 Next Data Register B (NDRB)

NDRB is an 8-bit readable/writable register that stores the next output data for TPC output groups 3 and 2 (pins TP<sub>15</sub> to TP<sub>8</sub>). During TPC output, when an 16-bit timer compare match event specified in TPCR occurs, NDRB contents are transferred to the corresponding bits in PBDR. The address of NDRB differs depending on whether TPC output groups 2 and 3 have the same output trigger or different output triggers.

NDRB is initialized to H'00 by a reset and in hardware standby mode. It is not initialized in software standby mode.

**Same Trigger for TPC Output Groups 2 and 3:** If TPC output groups 2 and 3 are triggered by the same compare match event, the NDRB address is H'FFFA4. The upper 4 bits belong to group 3 and the lower 4 bits to group 2. Address H'FFFA6 consists entirely of reserved bits that cannot be modified and always read 1.

Address H'FFFA4

Bit	7	6	5	4	3	2	1	0
	NDR15	NDR14	NDR13	NDR12	NDR11	NDR10	NDR9	NDR8
Initial value	0	0	0	0	0	0	0	0
Read/Write	R/W	R/W	R/W	R/W	R/W	R/W	R/W	R/W

<b>Next data 15 to 12</b>	<b>Next data 11 to 8</b>
These bits store the next output data for TPC output group 3	These bits store the next output data for TPC output group 2

Address H'FFFA6

Bit	7	6	5	4	3	2	1	0
	—	—	—	—	—	—	—	—
Initial value	1	1	1	1	1	1	1	1
Read/Write	—	—	—	—	—	—	—	—

<b>Reserved bits</b>
----------------------

**Different Triggers for TPC Output Groups 2 and 3:** If TPC output groups 2 and 3 are triggered by different compare match events, the address of the upper 4 bits of NDRB (group 3) is H'FFFA4 and the address of the lower 4 bits (group 2) is H'FFFA6. Bits 3 to 0 of address H'FFFA4 and bits 7 to 4 of address H'FFFA6 are reserved bits that cannot be modified and always read 1.

Address H'FFFA4

Bit	7	6	5	4	3	2	1	0
	NDR15	NDR14	NDR13	NDR12	—	—	—	—
Initial value	0	0	0	0	1	1	1	1
Read/Write	R/W	R/W	R/W	R/W	—	—	—	—

**Next data 15 to 12**  
These bits store the next output data for TPC output group 3
**Reserved bits**

Address H'FFFA6

Bit	7	6	5	4	3	2	1	0
	—	—	—	—	NDR11	NDR10	NDR9	NDR8
Initial value	1	1	1	1	0	0	0	0
Read/Write	—	—	—	—	R/W	R/W	R/W	R/W

**Reserved bits**
**Next data 11 to 8**  
These bits store the next output data for TPC output group 2



## 11.2.7 Next Data Enable Register A (NDERA)

NDERA is an 8-bit readable/writable register that enables or disables TPC output groups 1 and 0 (TP<sub>7</sub> to TP<sub>0</sub>) on a bit-by-bit basis.

Bit	7	6	5	4	3	2	1	0
	NDER7	NDER6	NDER5	NDER4	NDER3	NDER2	NDER1	NDER0
Initial value	0	0	0	0	0	0	0	0
Read/Write	R/W	R/W	R/W	R/W	R/W	R/W	R/W	R/W

### Next data enable 7 to 0

These bits enable or disable  
TPC output groups 1 and 0

If a bit is enabled for TPC output by NDERA, then when the 16-bit timer compare match event selected in the TPC output control register (TPCR) occurs, the NDRA value is automatically transferred to the corresponding PADR bit, updating the output value. If TPC output is disabled, the bit value is not transferred from NDRA to PADR and the output value does not change.

NDERA is initialized to H'00 by a reset and in hardware standby mode. It is not initialized in software standby mode.

**Bits 7 to 0—Next Data Enable 7 to 0 (NDER7 to NDER0):** These bits enable or disable TPC output groups 1 and 0 (TP<sub>7</sub> to TP<sub>0</sub>) on a bit-by-bit basis.

### Bits 7 to 0

NDER7 to NDER0	Description
0	TPC outputs TP <sub>7</sub> to TP <sub>0</sub> are disabled (NDR7 to NDR0 are not transferred to PA <sub>7</sub> to PA <sub>0</sub> ) (Initial value)
1	TPC outputs TP <sub>7</sub> to TP <sub>0</sub> are enabled (NDR7 to NDR0 are transferred to PA <sub>7</sub> to PA <sub>0</sub> )

## 11.2.8 Next Data Enable Register B (NDERB)

NDERB is an 8-bit readable/writable register that enables or disables TPC output groups 3 and 2 (TP<sub>15</sub> to TP<sub>8</sub>) on a bit-by-bit basis.

Bit	7	6	5	4	3	2	1	0
	NDER15	NDER14	NDER13	NDER12	NDER11	NDER10	NDER9	NDER8
Initial value	0	0	0	0	0	0	0	0
Read/Write	R/W	R/W	R/W	R/W	R/W	R/W	R/W	R/W

### Next data enable 15 to 8

These bits enable or disable  
TPC output groups 3 and 2

If a bit is enabled for TPC output by NDERB, then when the 16-bit timer compare match event selected in the TPC output control register (TPCR) occurs, the NDRB value is automatically transferred to the corresponding PBDR bit, updating the output value. If TPC output is disabled, the bit value is not transferred from NDRB to PBDR and the output value does not change.

NDERB is initialized to H'00 by a reset and in hardware standby mode. It is not initialized in software standby mode.

**Bits 7 to 0—Next Data Enable 15 to 8 (NDER15 to NDER8):** These bits enable or disable TPC output groups 3 and 2 (TP<sub>15</sub> to TP<sub>8</sub>) on a bit-by-bit basis.

### Bits 7 to 0

NDER15 to NDER8	Description
0	TPC outputs TP <sub>15</sub> to TP <sub>8</sub> are disabled (NDR15 to NDR8 are not transferred to PB <sub>7</sub> to PB <sub>0</sub> ) (Initial value)
1	TPC outputs TP <sub>15</sub> to TP <sub>8</sub> are enabled (NDR15 to NDR8 are transferred to PB <sub>7</sub> to PB <sub>0</sub> )

## 11.2.9 TPC Output Control Register (TPCR)

TPCR is an 8-bit readable/writable register that selects output trigger signals for TPC outputs on a group-by-group basis.

Bit	7	6	5	4	3	2	1	0
	G3CMS1	G3CMS0	G2CMS1	G2CMS0	G1CMS1	G1CMS0	G0CMS1	G0CMS0
Initial value	1	1	1	1	1	1	1	1
Read/Write	R/W	R/W	R/W	R/W	R/W	R/W	R/W	R/W

**Group 3 compare match select 1 and 0**  
These bits select the compare match event that triggers TPC output group 3 (TP<sub>15</sub> to TP<sub>12</sub>)

**Group 2 compare match select 1 and 0**  
These bits select the compare match event that triggers TPC output group 2 (TP<sub>11</sub> to TP<sub>8</sub>)

**Group 1 compare match select 1 and 0**  
These bits select the compare match event that triggers TPC output group 1 (TP<sub>7</sub> to TP<sub>4</sub>)

**Group 0 compare match select 1 and 0**  
These bits select the compare match event that triggers TPC output group 0 (TP<sub>3</sub> to TP<sub>0</sub>)

TPCR is initialized to H'FF by a reset and in hardware standby mode. It is not initialized in software standby mode.

**Bits 7 and 6—Group 3 Compare Match Select 1 and 0 (G3CMS1, G3CMS0):** These bits select the compare match event that triggers TPC output group 3 (TP<sub>15</sub> to TP<sub>12</sub>).

Bit 7 G3CMS1	Bit 6 G3CMS0	Description
0	0	TPC output group 3 (TP <sub>15</sub> to TP <sub>12</sub> ) is triggered by compare match in 16-bit timer channel 0
	1	TPC output group 3 (TP <sub>15</sub> to TP <sub>12</sub> ) is triggered by compare match in 16-bit timer channel 1
1	0	TPC output group 3 (TP <sub>15</sub> to TP <sub>12</sub> ) is triggered by compare match in 16-bit timer channel 2
	1	TPC output group 3 (TP <sub>15</sub> to TP <sub>12</sub> ) is triggered by compare match in 16-bit timer channel 2 (Initial value)

**Bits 5 and 4—Group 2 Compare Match Select 1 and 0 (G2CMS1, G2CMS0):** These bits select the compare match event that triggers TPC output group 2 (TP<sub>11</sub> to TP<sub>8</sub>).

Bit 5 G2CMS1	Bit 4 G2CMS0	Description
0	0	TPC output group 2 (TP <sub>11</sub> to TP <sub>8</sub> ) is triggered by compare match in 16-bit timer channel 0
	1	TPC output group 2 (TP <sub>11</sub> to TP <sub>8</sub> ) is triggered by compare match in 16-bit timer channel 1
1	0	TPC output group 2 (TP <sub>11</sub> to TP <sub>8</sub> ) is triggered by compare match in 16-bit timer channel 2
	1	TPC output group 2 (TP <sub>11</sub> to TP <sub>8</sub> ) is triggered by compare match in 16-bit timer channel 2 (Initial value)

**Bits 3 and 2—Group 1 Compare Match Select 1 and 0 (G1CMS1, G1CMS0):** These bits select the compare match event that triggers TPC output group 1 (TP<sub>7</sub> to TP<sub>4</sub>).

Bit 3 G1CMS1	Bit 2 G1CMS0	Description
0	0	TPC output group 1 (TP <sub>7</sub> to TP <sub>4</sub> ) is triggered by compare match in 16-bit timer channel 0
	1	TPC output group 1 (TP <sub>7</sub> to TP <sub>4</sub> ) is triggered by compare match in 16-bit timer channel 1
1	0	TPC output group 1 (TP <sub>7</sub> to TP <sub>4</sub> ) is triggered by compare match in 16-bit timer channel 2
	1	TPC output group 1 (TP <sub>7</sub> to TP <sub>4</sub> ) is triggered by compare match in 16-bit timer channel 2 (Initial value)

**Bits 1 and 0—Group 0 Compare Match Select 1 and 0 (G0CMS1, G0CMS0):** These bits select the compare match event that triggers TPC output group 0 (TP<sub>3</sub> to TP<sub>0</sub>).

Bit 1 G0CMS1	Bit 0 G0CMS0	Description
0	0	TPC output group 0 (TP <sub>3</sub> to TP <sub>0</sub> ) is triggered by compare match in 16-bit timer channel 0
	1	TPC output group 0 (TP <sub>3</sub> to TP <sub>0</sub> ) is triggered by compare match in 16-bit timer channel 1
1	0	TPC output group 0 (TP <sub>3</sub> to TP <sub>0</sub> ) is triggered by compare match in 16-bit timer channel 2
	1	TPC output group 0 (TP <sub>3</sub> to TP <sub>0</sub> ) is triggered by compare match in 16-bit timer channel 2 (Initial value)

## 11.2.10 TPC Output Mode Register (TPMR)

TPMR is an 8-bit readable/writable register that selects normal or non-overlapping TPC output for each group.

Bit	7	6	5	4	3	2	1	0
	—	—	—	—	G3NOV	G2NOV	G1NOV	G0NOV
Initial value	1	1	1	1	0	0	0	0
Read/Write	—	—	—	—	R/W	R/W	R/W	R/W

**Reserved bits**

**Group 3 non-overlap**  
Selects non-overlapping TPC output for group 3 (TP<sub>15</sub> to TP<sub>12</sub>)

**Group 2 non-overlap**  
Selects non-overlapping TPC output for group 2 (TP<sub>11</sub> to TP<sub>8</sub>)

**Group 1 non-overlap**  
Selects non-overlapping TPC output for group 1 (TP<sub>7</sub> to TP<sub>4</sub>)

**Group 0 non-overlap**  
Selects non-overlapping TPC output for group 0 (TP<sub>3</sub> to TP<sub>0</sub>)

The output trigger period of a non-overlapping TPC output waveform is set in general register B (GRB) in the 16-bit timer channel selected for output triggering. The non-overlap margin is set in general register A (GRA). The output values change at compare match A and B. For details see section 11.3.4, Non-Overlapping TPC Output.

TPMR is initialized to H'F0 by a reset and in hardware standby mode. It is not initialized in software standby mode.

**Bits 7 to 4—Reserved:** These bits cannot be modified and are always read as 1.

**Bit 3—Group 3 Non-Overlap (G3NOV):** Selects normal or non-overlapping TPC output for group 3 (TP<sub>15</sub> to TP<sub>12</sub>).

**Bit 3**

G3NOV	Description	
0	Normal TPC output in group 3 (output values change at compare match A in the selected 16-bit timer channel)	(Initial value)
1	Non-overlapping TPC output in group 3 (independent 1 and 0 output at compare match A and B in the selected 16-bit timer channel)	

**Bit 2—Group 2 Non-Overlap (G2NOV):** Selects normal or non-overlapping TPC output for group 2 (TP<sub>11</sub> to TP<sub>8</sub>).

**Bit 2**

G2NOV	Description	
0	Normal TPC output in group 2 (output values change at compare match A in the selected 16-bit timer channel)	(Initial value)
1	Non-overlapping TPC output in group 2 (independent 1 and 0 output at compare match A and B in the selected 16-bit timer channel)	

**Bit 1—Group 1 Non-Overlap (G1NOV):** Selects normal or non-overlapping TPC output for group 1 (TP<sub>7</sub> to TP<sub>4</sub>).

**Bit 1**

G1NOV	Description	
0	Normal TPC output in group 1 (output values change at compare match A in the selected 16-bit timer channel)	(Initial value)
1	Non-overlapping TPC output in group 1 (independent 1 and 0 output at compare match A and B in the selected 16-bit timer channel)	

**Bit 0—Group 0 Non-Overlap (G0NOV):** Selects normal or non-overlapping TPC output for group 0 (TP<sub>3</sub> to TP<sub>0</sub>).

**Bit 0**

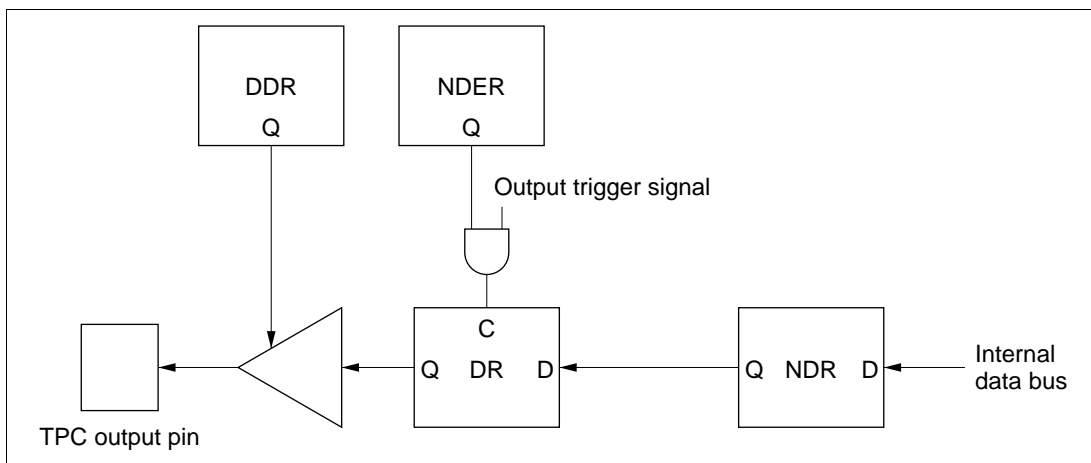
G0NOV	Description	
0	Normal TPC output in group 0 (output values change at compare match A in the selected 16-bit timer channel)	(Initial value)
1	Non-overlapping TPC output in group 0 (independent 1 and 0 output at compare match A and B in the selected 16-bit timer channel)	

## 11.3 Operation

### 11.3.1 Overview

When corresponding bits in PADDR or PBDDR and NDERA or NDERB are set to 1, TPC output is enabled. The TPC output initially consists of the corresponding PADDR or PBDDR contents. When a compare-match event selected in TPCR occurs, the corresponding NDRA or NDRB bit contents are transferred to PADDR or PBDDR to update the output values.

Figure 11.2 illustrates the TPC output operation. Table 11.3 summarizes the TPC operating conditions.



**Figure 11.2 TPC Output Operation**

**Table 11.3 TPC Operating Conditions**

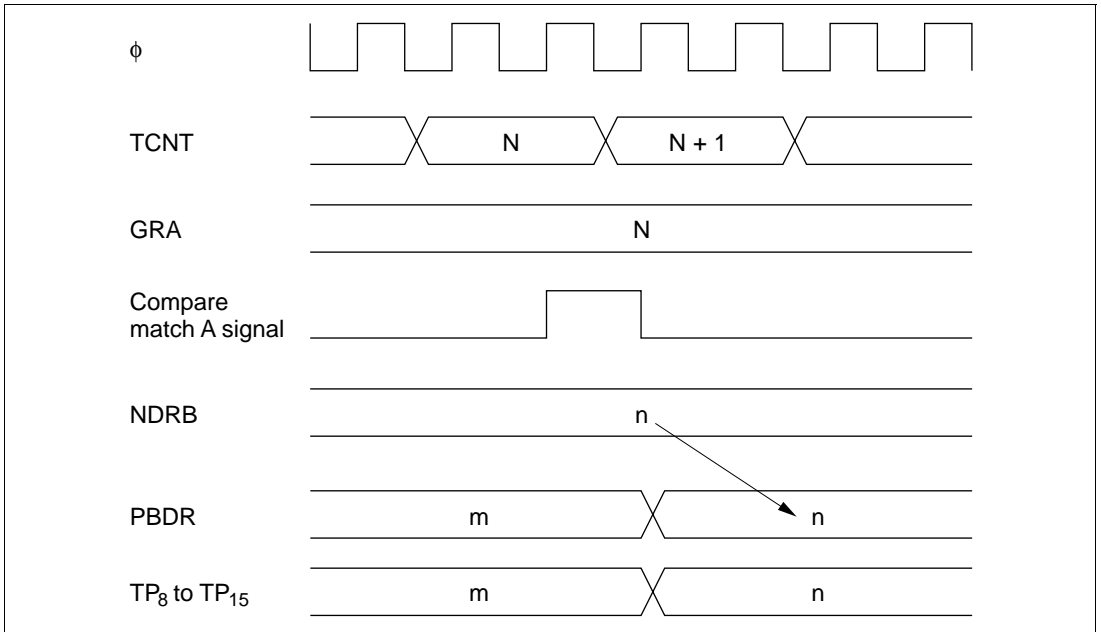
NDER	DDR	Pin Function
0	0	Generic input port
	1	Generic output port
1	0	Generic input port (but the DR bit is a read-only bit, and when compare match occurs, the NDR bit value is transferred to the DR bit)
	1	TPC pulse output

Sequential output of up to 16-bit patterns is possible by writing new output data to NDRA and NDRB before the next compare match. For information on non-overlapping operation, see section 11.3.4, Non-Overlapping TPC Output.



### 11.3.2 Output Timing

If TPC output is enabled, NDRA/NDRB contents are transferred to PADR/PBDR and output when the selected compare match event occurs. Figure 11.3 shows the timing of these operations for the case of normal output in groups 2 and 3, triggered by compare match A.



**Figure 11.3 Timing of Transfer of Next Data Register Contents and Output (Example)**

### 11.3.3 Normal TPC Output

Sample Setup Procedure for Normal TPC Output: Figure 11.4 shows a sample procedure for setting up normal TPC output.

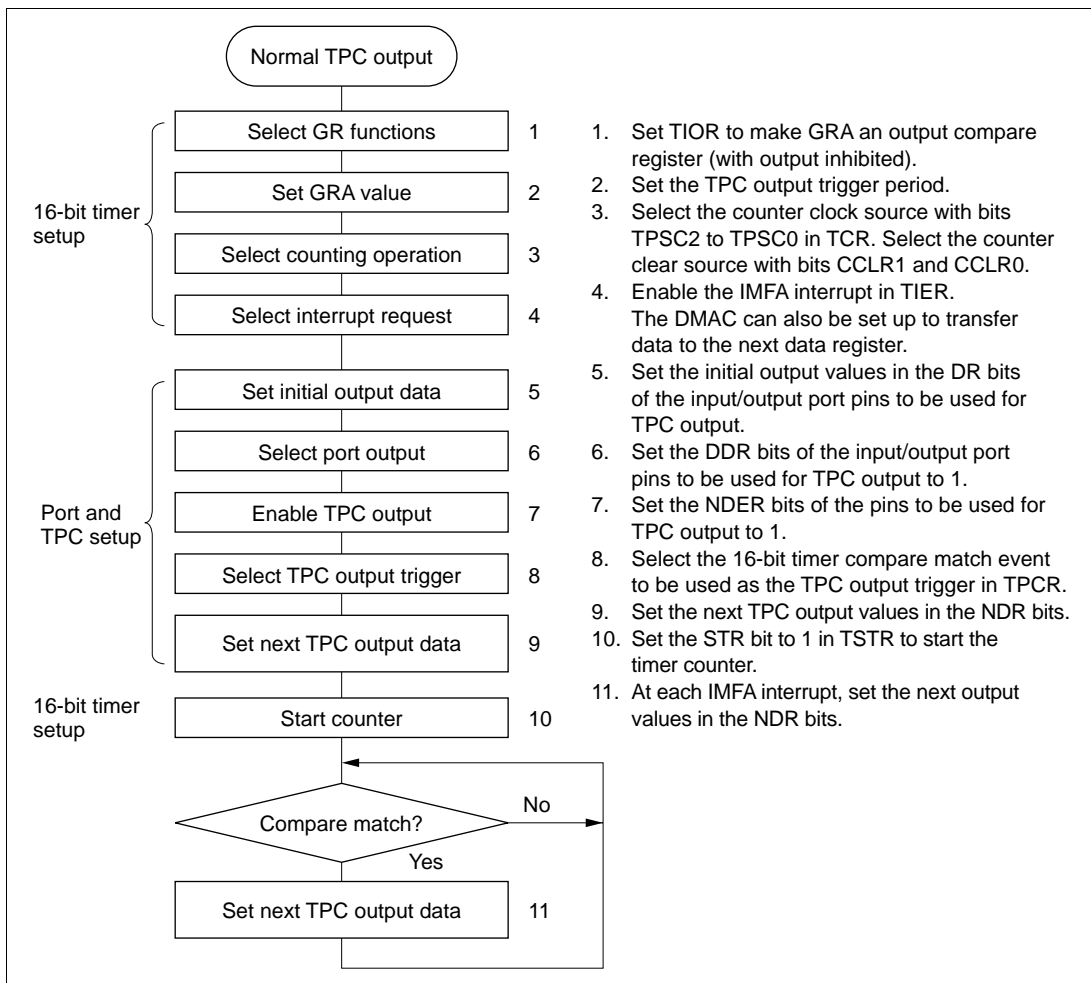
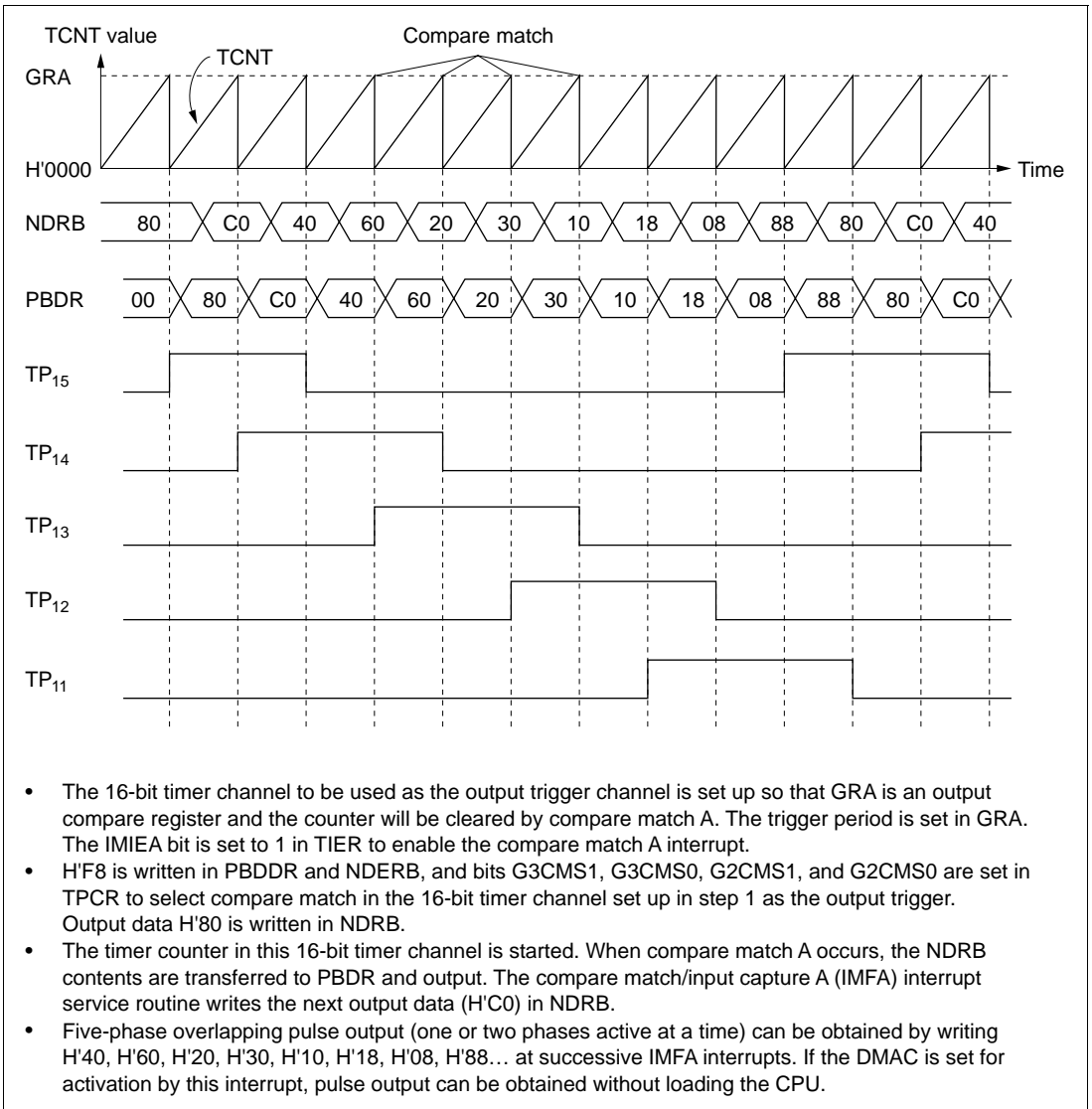


Figure 11.4 Setup Procedure for Normal TPC Output (Example)

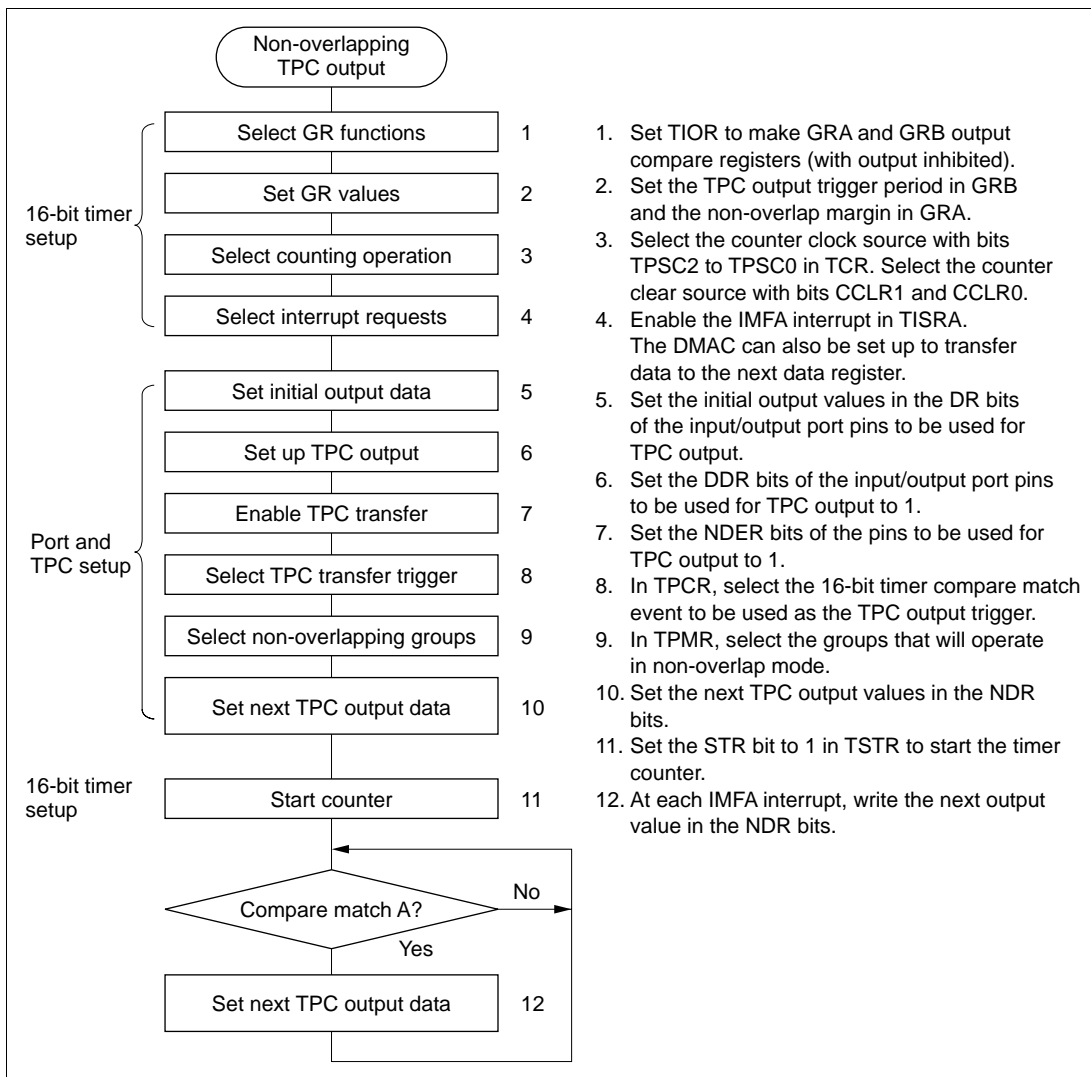
**Example of Normal TPC Output (Example of Five-Phase Pulse Output):** Figure 11.5 shows an example in which the TPC is used for cyclic five-phase pulse output.



**Figure 11.5 Normal TPC Output Example (Five-Phase Pulse Output)**

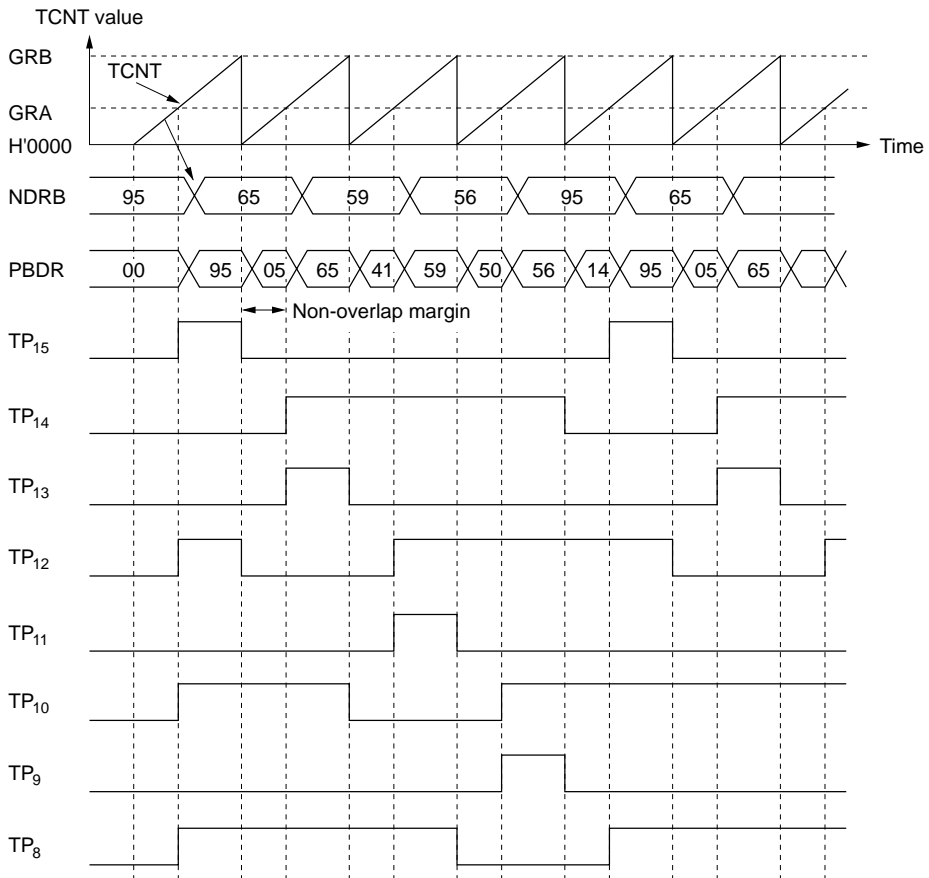
### 11.3.4 Non-Overlapping TPC Output

**Sample Setup Procedure for Non-Overlapping TPC Output:** Figure 11.6 shows a sample procedure for setting up non-overlapping TPC output.



**Figure 11.6 Setup Procedure for Non-Overlapping TPC Output (Example)**

**Example of Non-Overlapping TPC Output (Example of Four-Phase Complementary Non-Overlapping Output):** Figure 11.7 shows an example of the use of TPC output for four-phase complementary non-overlapping pulse output.

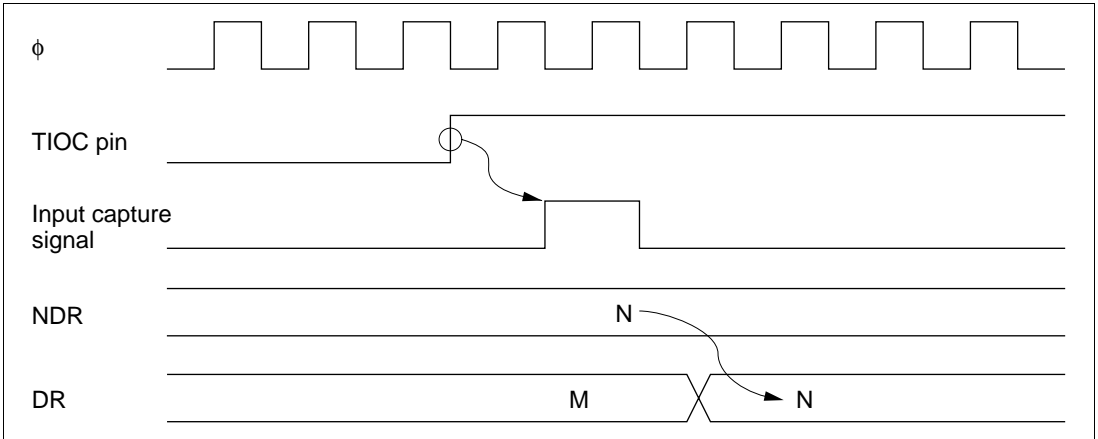


- The 16-bit timer channel to be used as the output trigger channel is set up so that GRA and GRB are output compare registers and the counter will be cleared by compare match B. The TPC output trigger period is set in GRB. The non-overlap margin is set in GRA. The IMIEA bit is set to 1 in TISRA to enable IMFA interrupts.
- H'FF is written in PBDDR and NDERB, and bits G3CMS1, G3CMS0, G2CMS1, and G2CMS0 are set in TPCR to select compare match in the 16-bit timer channel set up in step 1 as the output trigger. Bits G3NOV and G2NOV are set to 1 in TPMP to select non-overlapping output. Output data H'95 is written in NDRB.
- The timer counter in this 16-bit timer channel is started. When compare match B occurs, outputs change from 1 to 0. When compare match A occurs, outputs change from 0 to 1 (the change from 0 to 1 is delayed by the value of GRA). The IMFA interrupt service routine writes the next output data (H'65) in NDRB.
- Four-phase complementary non-overlapping pulse output can be obtained by writing H'59, H'56, H'95... at successive IMFA interrupts. If the DMAC is set for activation by this interrupt, pulse output can be obtained without loading the CPU.

**Figure 11.7 Non-Overlapping TPC Output Example (Four-Phase Complementary Non-Overlapping Pulse Output)**

### 11.3.5 TPC Output Triggering by Input Capture

TPC output can be triggered by 16-bit timer input capture as well as by compare match. If GRA functions as an input capture register in the 16-bit timer channel selected in TPCR, TPC output will be triggered by the input capture signal. Figure 11.8 shows the timing.



**Figure 11.8 TPC Output Triggering by Input Capture (Example)**

## 11.4 Usage Notes

### 11.4.1 Operation of TPC Output Pins

TP<sub>0</sub> to TP<sub>15</sub> are multiplexed with 16-bit timer, DMAC, address bus, and other pin functions. When 16-bit timer, DMAC, or address output is enabled, the corresponding pins cannot be used for TPC output. The data transfer from NDR bits to DR bits takes place, however, regardless of the usage of the pin.

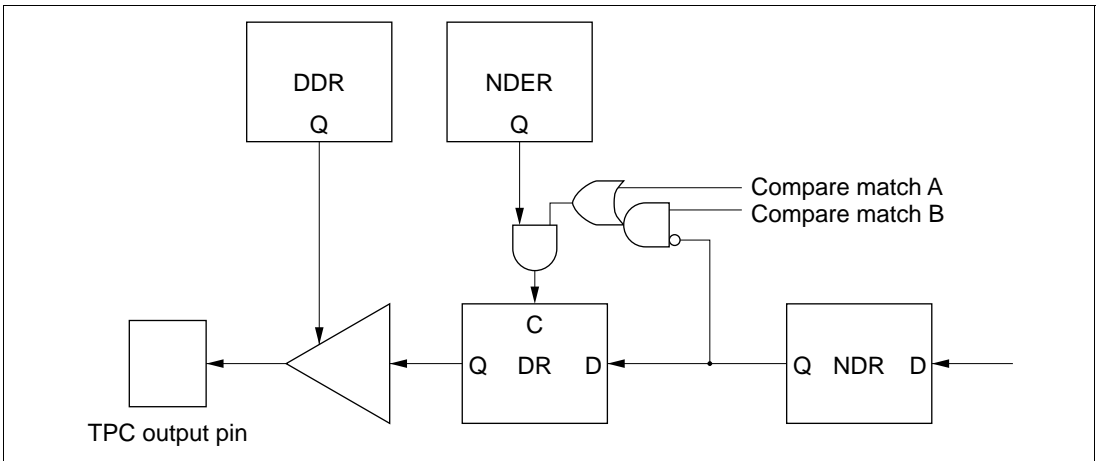
Pin functions should be changed only under conditions in which the output trigger event will not occur.

### 11.4.2 Note on Non-Overlapping Output

During non-overlapping operation, the transfer of NDR bit values to DR bits takes place as follows.

1. NDR bits are always transferred to DR bits at compare match A.
2. At compare match B, NDR bits are transferred only if their value is 0. Bits are not transferred if their value is 1.

Figure 11.9 illustrates the non-overlapping TPC output operation.

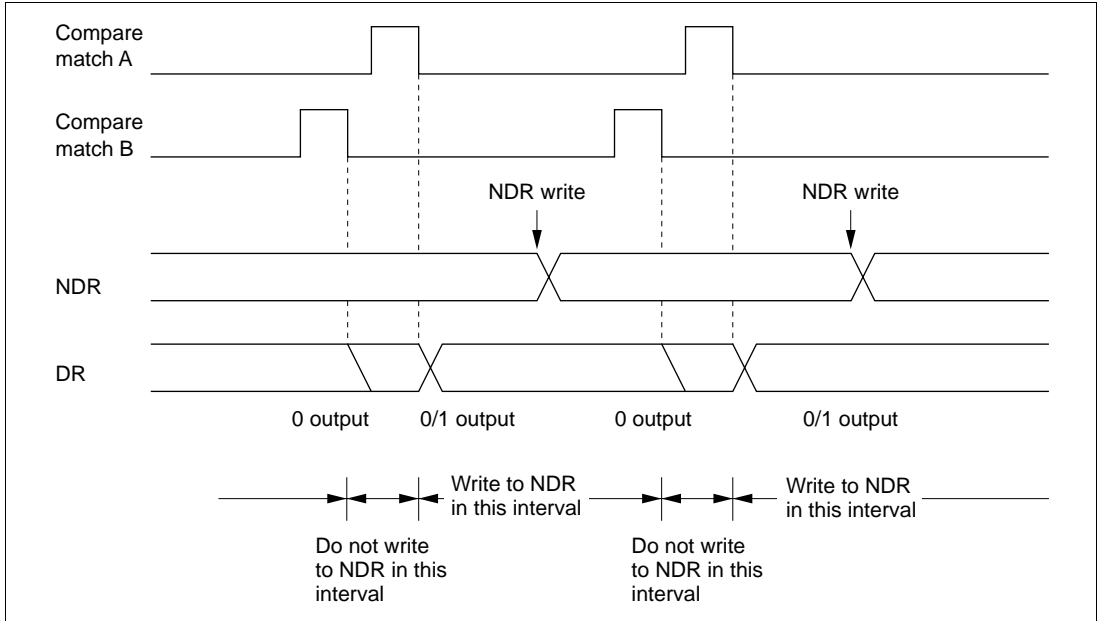


**Figure 11.9 Non-Overlapping TPC Output**

Therefore, 0 data can be transferred ahead of 1 data by making compare match B occur before compare match A. NDR contents should not be altered during the interval from compare match B to compare match A (the non-overlap margin).

This can be accomplished by having the IMFA interrupt service routine write the next data in NDR, or by having the IMFA interrupt activate the DMAC. The next data must be written before the next compare match B occurs.

Figure 11.10 shows the timing relationships.



**Figure 11.10 Non-Overlapping Operation and NDR Write Timing**



# Section 12 Watchdog Timer

## 12.1 Overview

The H8/3067 has an on-chip watchdog timer (WDT). The WDT has two selectable functions: it can operate as a watchdog timer to supervise system operation, or it can operate as an interval timer. As a watchdog timer, it generates a reset signal for the H8/3067 chip if a system crash allows the timer counter (TCNT) to overflow before being rewritten. In interval timer operation, an interval timer interrupt is requested at each TCNT overflow.

### 12.1.1 Features

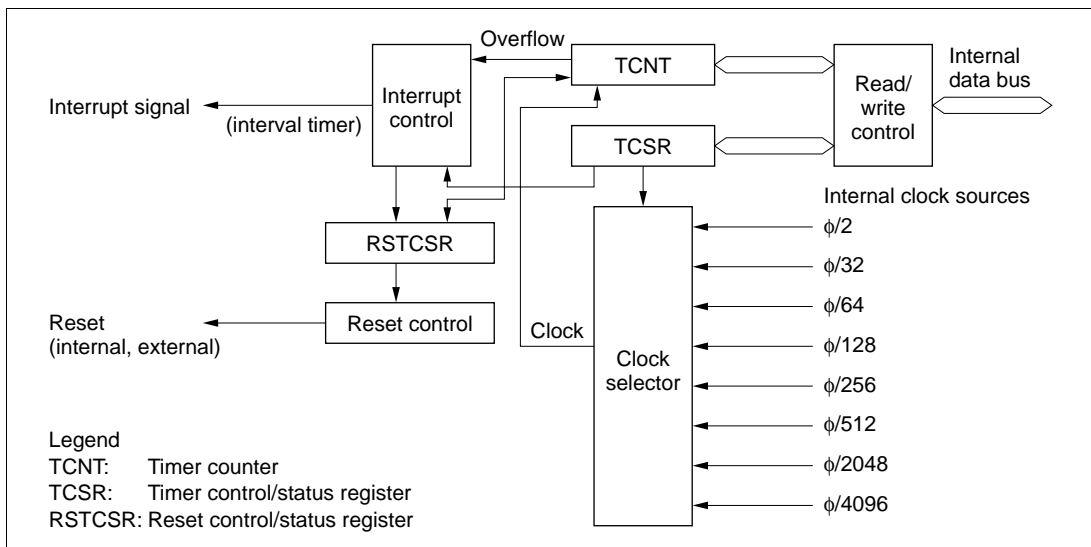
WDT features are listed below.

- Selection of eight counter clock sources  
 $\phi/2$ ,  $\phi/32$ ,  $\phi/64$ ,  $\phi/128$ ,  $\phi/256$ ,  $\phi/512$ ,  $\phi/2048$ , or  $\phi/4096$
- Interval timer option
- Timer counter overflow generates a reset signal or interrupt.  
The reset signal is generated in watchdog timer operation. An interval timer interrupt is generated in interval timer operation.
- Watchdog timer reset signal resets the entire H8/3067 internally, and can also be output externally.

The reset signal generated by timer counter overflow during watchdog timer operation resets the entire H8/3067 internally. An external reset signal can be output from the  $\overline{\text{RESO}}$  pin to reset other system devices simultaneously. This function is not provided in the flash memory and flash memory R versions.

## 12.1.2 Block Diagram

Figure 12.1 shows a block diagram of the WDT.



**Figure 12.1 WDT Block Diagram**

## 12.1.3 Pin Configuration

Table 12.1 describes the WDT output pin\*<sup>1</sup>.

**Table 12.1 WDT Pin**

Name	Abbreviation	I/O	Function
Reset output	$\overline{\text{RESO}}$	Output* <sup>2</sup>	External output of the watchdog timer reset signal

Notes: 1. Not present in the flash memory and flash memory R versions.

2. Open-drain output.

## 12.1.4 Register Configuration

Table 12.2 summarizes the WDT registers.

**Table 12.2 WDT Registers**

<b>Address*<sup>1</sup></b>					
<b>Write*<sup>2</sup></b>	<b>Read</b>	<b>Name</b>	<b>Abbreviation</b>	<b>R/W</b>	<b>Initial Value</b>
H'FFF8C	H'FFF8C	Timer control/status register	TCSR	R/(W)* <sup>3</sup>	H'18
	H'FFF8D	Timer counter	TCNT	R/W	H'00
H'FFF8E	H'FFF8F	Reset control/status register	RSTCSR	R/(W)* <sup>3</sup>	H'3F

Notes: 1. Lower 20 bits of the address in advanced mode.  
2. Write word data starting at this address.  
3. Only 0 can be written in bit 7, to clear the flag.

## 12.2 Register Descriptions

### 12.2.1 Timer Counter (TCNT)

TCNT is an 8-bit readable and writable up-counter.

Bit	7	6	5	4	3	2	1	0
Initial value	0	0	0	0	0	0	0	0
Read/Write	R/W	R/W	R/W	R/W	R/W	R/W	R/W	R/W

Note: TCNT is write-protected by a password. For details see section 12.2.4, Notes on Register Access.

When the TME bit is set to 1 in TCSR, TCNT starts counting pulses generated from an internal clock source selected by bits CKS2 to CKS0 in TCSR. When the count overflows (changes from H'FF to H'00), the OVF bit is set to 1 in TCSR. TCNT is initialized to H'00 by a reset and when the TME bit is cleared to 0.

## 12.2.2 Timer Control/Status Register (TCSR)

TCSR is an 8-bit readable and writable register. Its functions include selecting the timer mode and clock source.

Bit	7	6	5	4	3	2	1	0
	OVF	WT/IT	TME	—	—	CKS2	CKS1	CKS0
Initial value	0	0	0	1	1	0	0	0
Read/Write	R/(W) *	R/W	R/W	—	—	R/W	R/W	R/W

**Overflow flag**  
 Status flag indicating overflow

**Timer mode select**  
 Selects the mode

**Timer enable**  
 Selects whether TCNT runs or halts

**Reserved bits**

**Clock select**  
 These bits select the TCNT clock source

Notes: TCSR is write-protected by a password. For details see section 12.2.4, Notes on Register Access.

\* Only 0 can be written, to clear the flag.

Bits 7 to 5 are initialized to 0 by a reset and in standby mode. Bits 2 to 0 are initialized to 0 by a reset. In software standby mode bits 2 to 0 are not initialized, but retain their previous values.

**Bit 7—Overflow Flag (OVF):** This status flag indicates that the timer counter has overflowed from H'FF to H'00.

Bit 7 OVF	Description
0	[Clearing condition] Cleared by reading OVF when OVF = 1, then writing 0 in OVF (Initial value)
1	[Setting condition] Set when TCNT changes from H'FF to H'00

**Bit 6—Timer Mode Select (WT/ $\overline{\text{IT}}$ ):** Selects whether to use the WDT as a watchdog timer or interval timer. If used as an interval timer, the WDT generates an interval timer interrupt request when TCNT overflows. If used as a watchdog timer, the WDT generates a reset signal when TCNT overflows.

Bit 6 WT/ $\overline{\text{IT}}$	Description
0	Interval timer: requests interval timer interrupts (Initial value)
1	Watchdog timer: generates a reset signal

**Bit 5—Timer Enable (TME):** Selects whether TCNT runs or is halted. When WT/ $\overline{\text{IT}}$  = 1, clear the software standby bit (SSBY) to 0 in SYSCR before setting TME. When setting SSBY to 1, TME should be cleared to 0.

Bit 5 TME	Description
0	TCNT is initialized to H'00 and halted (Initial value)
1	TCNT is counting

**Bits 4 and 3—Reserved:** These bits cannot be modified and are always read as 1.

**Bits 2 to 0—Clock Select 2 to 0 (CKS2/1/0):** These bits select one of eight internal clock sources, obtained by prescaling the system clock ( $\phi$ ), for input to TCNT.

Bit 2 CKS2	Bit 1 CKS1	Bit 0 CKS0	Description
0	0	0	$\phi/2$ (Initial value)
		1	$\phi/32$
	1	0	$\phi/64$
		1	$\phi/128$
1	0	0	$\phi/256$
		1	$\phi/512$
	1	0	$\phi/2048$
		1	$\phi/4096$

### 12.2.3 Reset Control/Status Register (RSTCSR)

RSTCSR is an 8-bit readable and writable register that indicates when a reset signal has been generated by watchdog timer overflow, and controls external output of the reset signal.

Bit	7	6	5	4	3	2	1	0
	WRST	RSTOE	—	—	—	—	—	—
Initial value	0	0	1	1	1	1	1	1
Read/Write	R/(W)*	R/W	—	—	—	—	—	—

**Reserved bits**

**Reset output enable**  
Enables or disables external output of the reset signal

**Watchdog timer reset**  
Indicates that a reset signal has been generated

Notes: RSTCSR is write-protected by a password. For details see section 12.2.4, Notes on Register Access.

\* Only 0 can be written in bit 7, to clear the flag.

Bits 7 and 6 are initialized by input of a reset signal at the  $\overline{\text{RES}}$  pin. They are not initialized by reset signals generated by watchdog timer overflow.

**Bit 7—Watchdog Timer Reset (WRST):** During watchdog timer operation, this bit indicates that TCNT has overflowed and generated a reset signal. This reset signal resets the entire H8/3067 chip internally. If bit RSTOE is set to 1, this reset signal is also output (low) at the  $\overline{\text{RESO}}$  pin to initialize external system devices. Note that there is no  $\overline{\text{RESO}}$  pin in the flash memory and flash memory R versions.

<b>Bit 7</b>	
<b>WRST</b>	<b>Description</b>
0	[Clearing condition] Reset signal at $\overline{\text{RES}}$ pin. Read WRST when WRST =1, then write 0 in WRST. (Initial value)
1	[Setting condition] Set when TCNT overflow generates a reset signal during watchdog timer operation

**Bit 6—Reset Output Enable (RSTOE):** Enables or disables external output at the  $\overline{\text{RESO}}$  pin of the reset signal generated if TCNT overflows during watchdog timer operation. Note that there is no  $\overline{\text{RESO}}$  pin in the flash memory and flash memory R versions.

<b>Bit 6</b>	
<b>RSTOE</b>	<b>Description</b>
0	Reset signal is not output externally (Initial value) (Initial value)
1	Reset signal is output externally

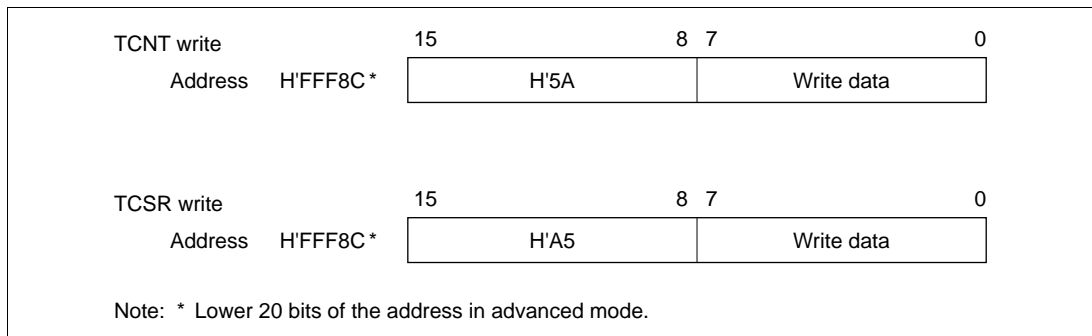
**Bits 5 to 0—Reserved:** These bits cannot be modified and are always read as 1.



## 12.2.4 Notes on Register Access

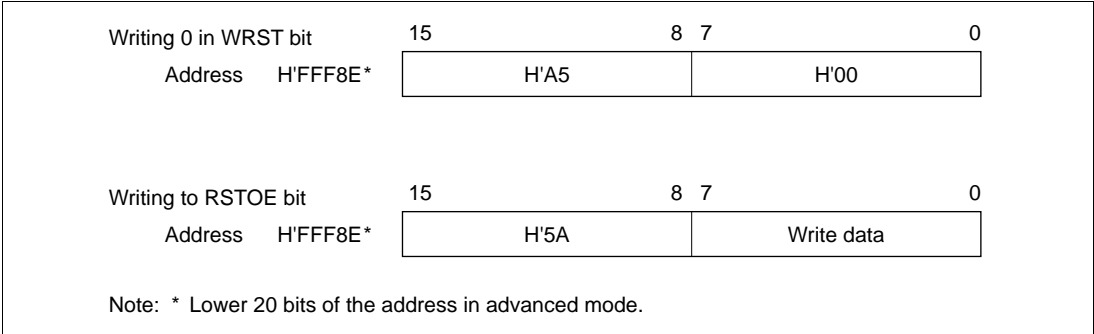
The watchdog timer's TCNT, TCSR, and RSTCSR registers differ from other registers in being more difficult to write. The procedures for writing and reading these registers are given below.

**Writing to TCNT and TCSR:** These registers must be written by a word transfer instruction. They cannot be written by byte instructions. Figure 12.2 shows the format of data written to TCNT and TCSR. TCNT and TCSR both have the same write address. The write data must be contained in the lower byte of the written word. The upper byte must contain H'5A (password for TCNT) or H'A5 (password for TCSR). This transfers the write data from the lower byte to TCNT or TCSR.



**Figure 12.2 Format of Data Written to TCNT and TCSR**

**Writing to RSTCSR:** RSTCSR must be written by a word transfer instruction. It cannot be written by byte transfer instructions. Figure 12.3 shows the format of data written to RSTCSR. To write 0 in the WRST bit, the write data must have H'A5 in the upper byte and H'00 in the lower byte. The data (H'00) in the lower byte is written to RSTCSR, clearing the WRST bit to 0. To write to the RSTOE bit, the upper byte must contain H'5A and the lower byte must contain the write data. Writing this word transfers a write data value into the RSTOE bit.



**Figure 12.3 Format of Data Written to RSTCSR**

**Reading TCNT, TCSR, and RSTCSR:** These registers are read like other registers. Reading TCNT, TCSR, and RSTCSR: These registers are read like other registers. Byte transfer instructions can be used. The read addresses are H'FFF8C for TCSR, H'FFF8D for TCNT, and H'FFF8F for RSTCSR, as listed in table 12-3.

**Table 12.3 Read Addresses of TCNT, TCSR, and RSTCSR**

Address*	Register
H'FFF8C	TCSR
H'FFF8D	TCNT
H'FFF8F	RSTCSR

Note: \* Lower 20 bits of the address in advanced mode.

## 12.3 Operation

Operations when the WDT is used as a watchdog timer and as an interval timer are described below.

### 12.3.1 Watchdog Timer Operation

Figure 12.4 illustrates watchdog timer operation. To use the WDT as a watchdog timer, set the  $\overline{WT}/\overline{IT}$  and  $\overline{TME}$  bits to 1 in  $\overline{TCSR}$ . Software must prevent  $\overline{TCNT}$  overflow by rewriting the  $\overline{TCNT}$  value (normally by writing H'00) before overflow occurs. If  $\overline{TCNT}$  fails to be rewritten and overflows due to a system crash etc., the H8/3067 is internally reset for a duration of 518 states.

The watchdog reset signal can be externally output from the  $\overline{RESO}$  pin to reset external system devices. The reset signal is output externally for 132 states. External output can be enabled or disabled by the  $\overline{RSTOE}$  bit in  $\overline{RSTCSR}$ . The  $\overline{RESO}$  pin function is not available in the flash memory and flash memory R versions.

A watchdog reset has the same vector as a reset generated by input at the  $\overline{RES}$  pin. Software can distinguish a  $\overline{RES}$  reset from a watchdog reset by checking the  $\overline{WRST}$  bit in  $\overline{RSTCSR}$ .

If a  $\overline{RES}$  reset and a watchdog reset occur simultaneously, the  $\overline{RES}$  reset takes priority.

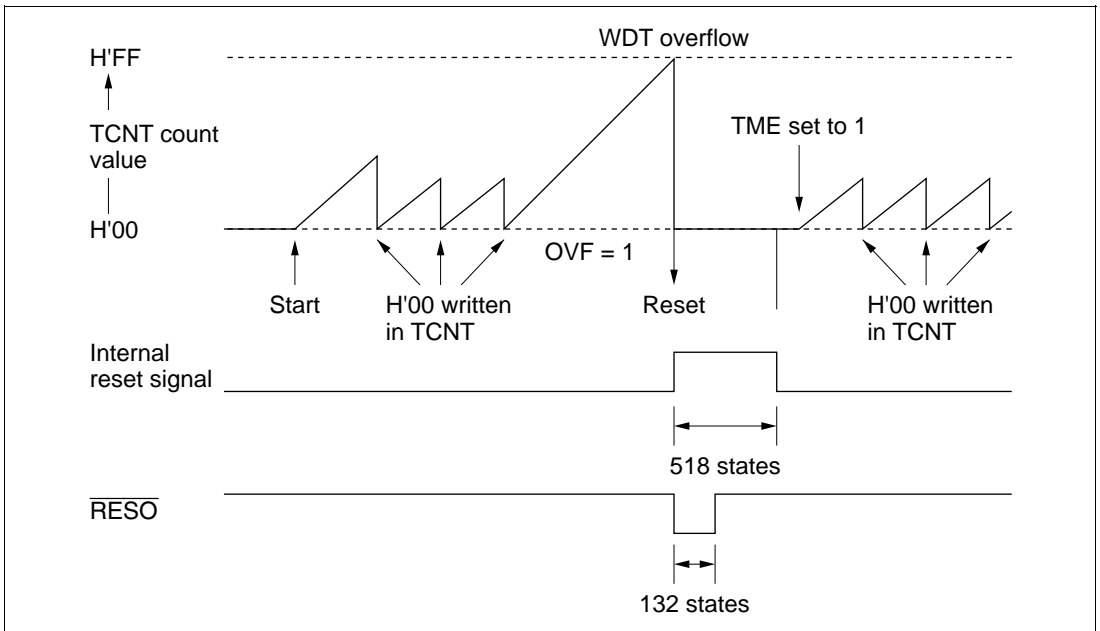
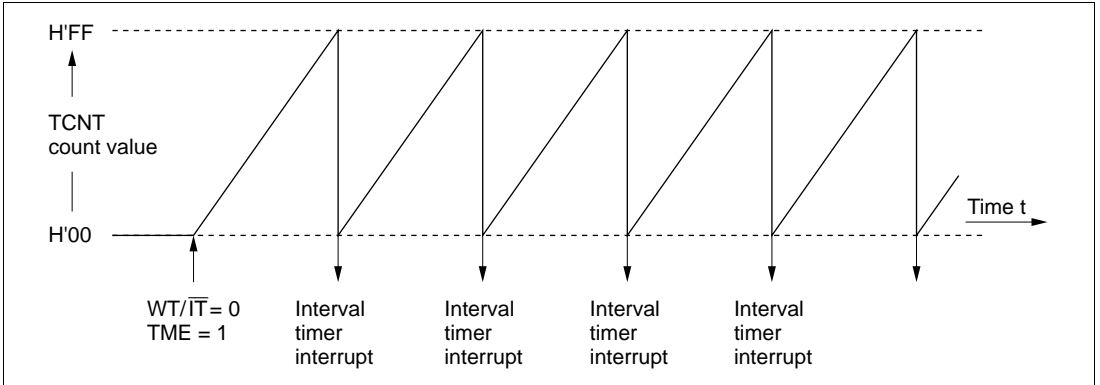


Figure 12.4 Operation in Watchdog Timer Mode

### 12.3.2 Interval Timer Operation

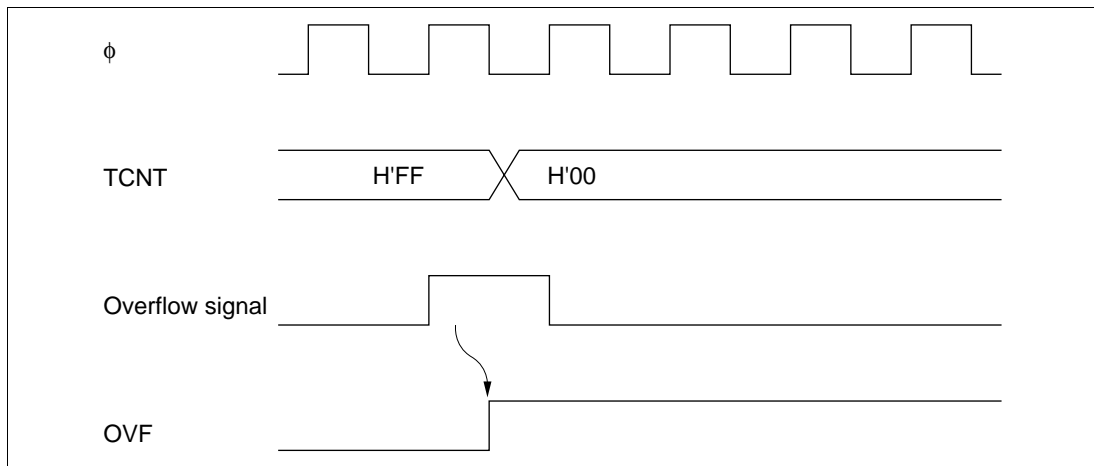
Figure 12.5 illustrates interval timer operation. To use the WDT as an interval timer, clear bit  $\overline{WT/IT}$  to 0 and set bit TME to 1 in TCSR. An interval timer interrupt request is generated at each TCNT overflow. This function can be used to generate interval timer interrupts at regular intervals.



**Figure 12.5 Interval Timer Operation**

### 12.3.3 Timing of Setting of Overflow Flag (OVF)

Figure 12.6 shows the timing of setting of the OVF flag. The OVF flag is set to 1 when TCNT overflows. At the same time, a reset signal is generated in watchdog timer operation, or an interval timer interrupt is generated in interval timer operation.

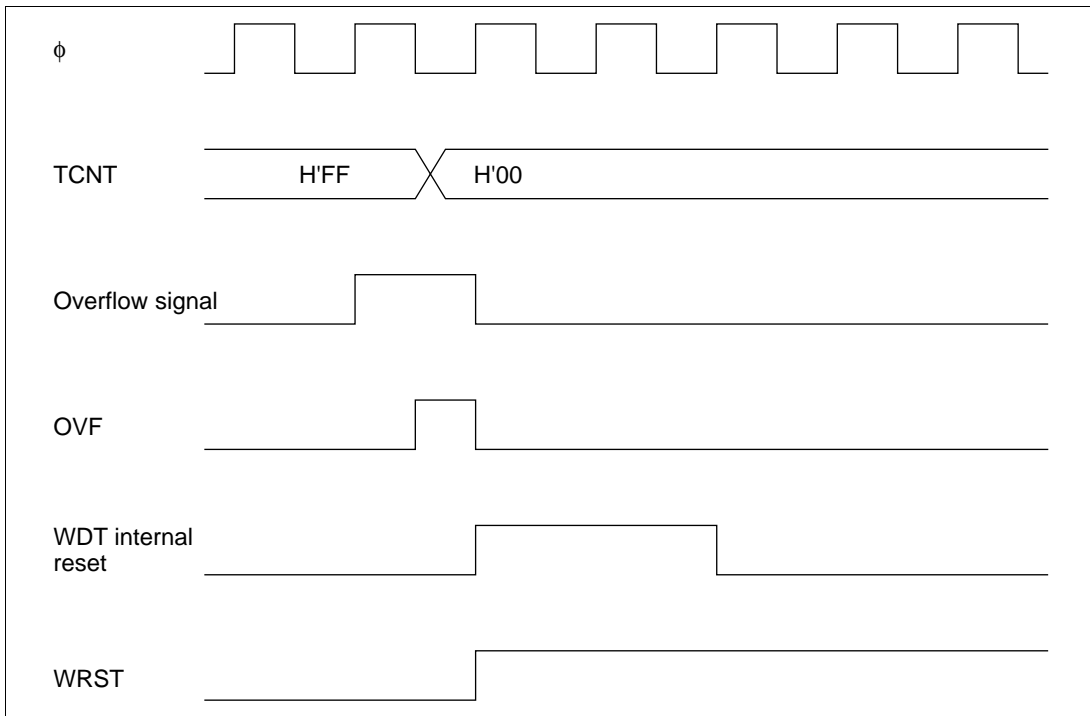


**Figure 12.6 Timing of Setting of OVF**

### 12.3.4 Timing of Setting of Watchdog Timer Reset Bit (WRST)

The WRST bit in RSTCSR is valid when bits  $\overline{WT/IT}$  and TME are both set to 1 in TCSR.

Figure 12.7 shows the timing of setting of WRST and the internal reset timing. The WRST bit is set to 1 when TCNT overflows and OVF is set to 1. At the same time an internal reset signal is generated for the entire H8/3067 chip. This internal reset signal clears OVF to 0, but the WRST bit remains set to 1. The reset routine must therefore clear the WRST bit.



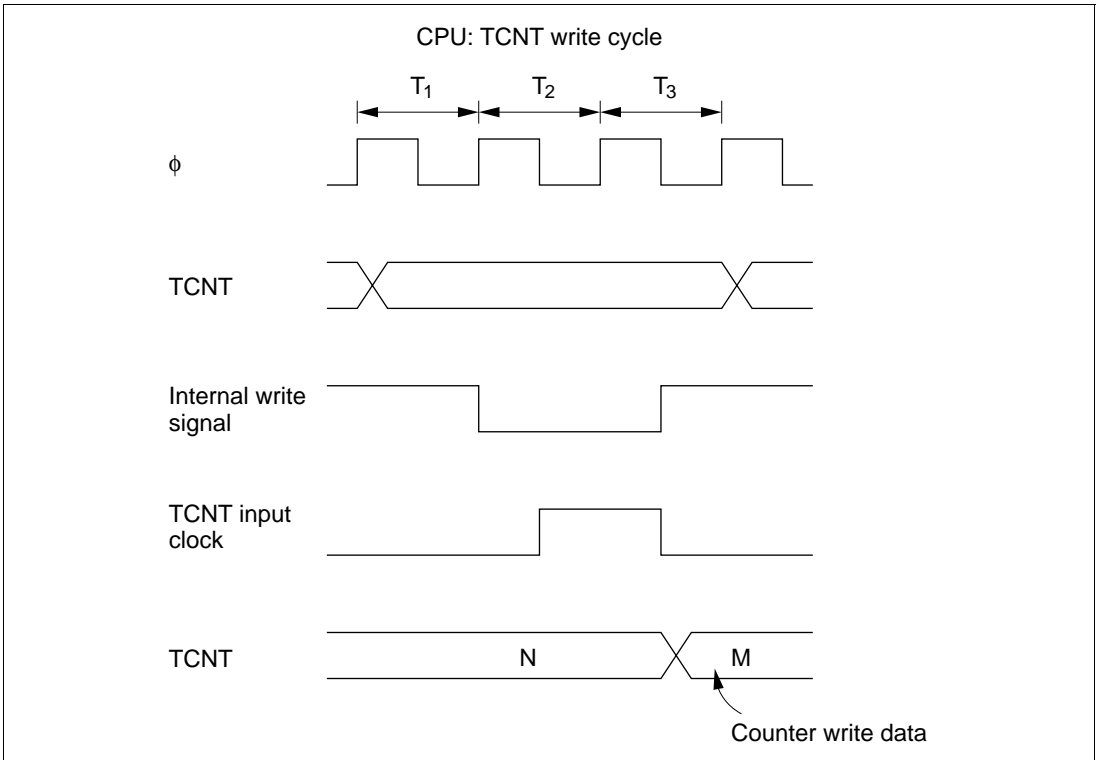
**Figure 12.7 Timing of Setting of WRST Bit and Internal Reset**

## 12.4 Interrupts

During interval timer operation, an overflow generates an interval timer interrupt (WOVI). The interval timer interrupt is requested whenever the OVF bit is set to 1 in TCSR.

## 12.5 Usage Notes

**Contention between TCNT Write and Increment:** If a timer counter clock pulse is generated during the  $T_3$  state of a write cycle to TCNT, the write takes priority and the timer count is not incremented. See figure 12.8.



**Figure 12.8 Contention between TCNT Write and Count up**

**Changing CKS2 to CKS0 Bit:** Halt TCNT by clearing the TME bit to 0 in TCSR before changing the values of bits CKS2 to CKS0.





# Section 13 Serial Communication Interface

## 13.1 Overview

The H8/3067 Series has a serial communication interface (SCI) with three independent channels. All three channels have identical functions. The SCI can communicate in both asynchronous and synchronous mode. It also has a multiprocessor communication function for serial communication among two or more processors.

When the SCI is not used, it can be halted to conserve power. Each SCI channel can be halted independently. For details, see section 20.6, Module Standby Function.

The SCI also has a smart card interface function conforming to the ISO/IEC 7816-3 (Identification Card) standard. This function supports serial communication with a smart card. Switching between the normal serial communication interface and the smart card interface is carried out by means of a register setting.

### 13.1.1 Features

SCI features are listed below.

- Selection of synchronous or asynchronous mode for serial communication

#### **Asynchronous mode**

Serial data communication is synchronized one channel at a time. The SCI can communicate with a universal asynchronous receiver/transmitter (UART), asynchronous communication interface adapter (ACIA), or other chip that employs standard asynchronous communication. It can also communicate with two or more other processors using the multiprocessor communication function. There are twelve selectable serial data transfer formats.

- Data length: 7 or 8 bits
- Stop bit length: 1 or 2 bits
- Parity: even/odd/none
- Multiprocessor bit: 1 or 0
- Receive error detection: parity, overrun, and framing errors
- Break detection: by reading the RxD level directly when a framing error occurs

#### **Synchronous mode**

Serial data communication is synchronized with a clock signal. The SCI can communicate with other chips having a synchronous communication function.

There is a single serial data communication format.

- Data length: 8 bits
- Receive error detection: overrun errors

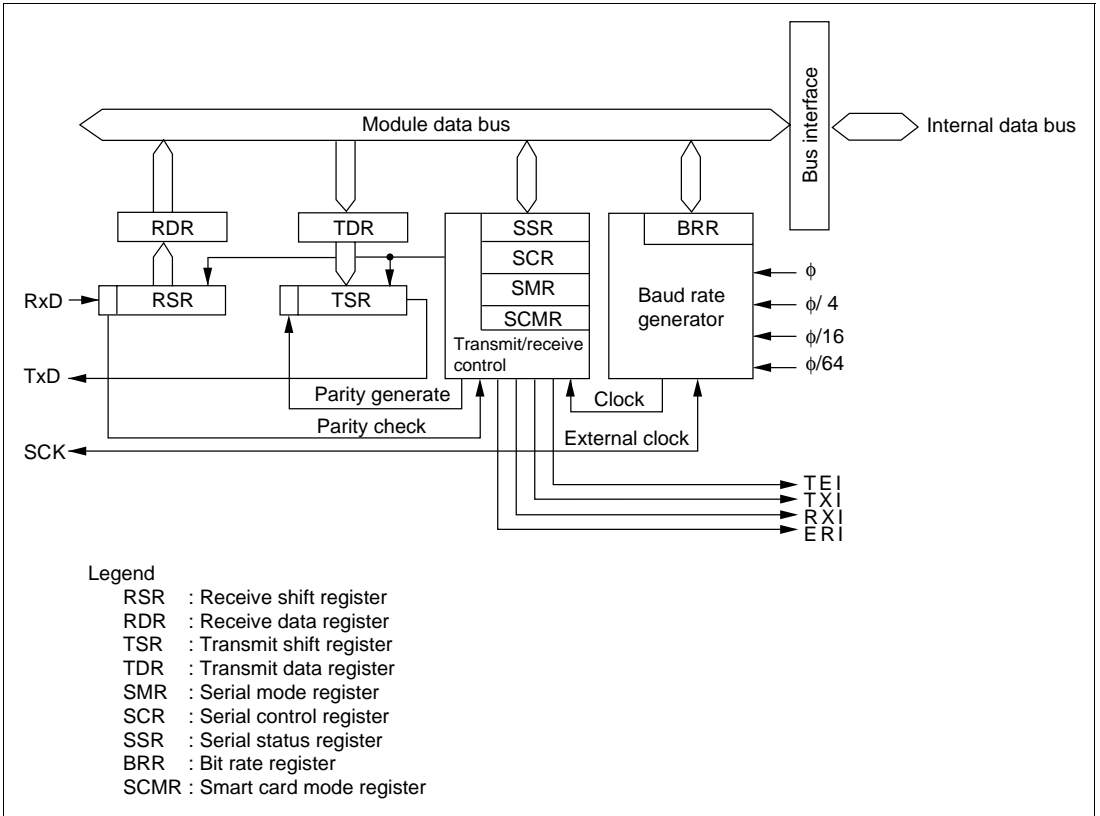
- Full-duplex communication  
The transmitting and receiving sections are independent, so the SCI can transmit and receive simultaneously. The transmitting and receiving sections are both double-buffered, so serial data can be transmitted and received continuously.
- The following settings can be made for the serial data to be transferred:
  - LSB-first or MSB-first transfer
  - Inversion of data logic level
- Built-in baud rate generator with selectable bit rates
- Selectable transmit/receive clock sources: internal clock from baud rate generator, or external clock from the SCK pin
- Four types of interrupts  
Transmit-data-empty, transmit-end, receive-data-full, and receive-error interrupts are requested independently. The transmit-data-empty and receive-data-full interrupts from SCIO can activate the DMA controller (DMAC) to transfer data.

Features of the smart card interface are listed below.

- Asynchronous communication
  - Data length: 8 bits
  - Parity bits generated and checked
  - Error signal output in receive mode (parity error)
  - Error signal detect and automatic data retransmit in transmit mode
  - Supports both direct convention and inverse convention
- Built-in baud rate generator with selectable bit rates
- Three types of interrupts  
Transmit-data-empty, receive-data-full, and transmit/receive-error interrupts are requested independently. The transmit-data-empty and receive-data-full interrupts can activate the DMA controller (DMAC) to transfer data.

## 13.1.2 Block Diagram

Figure 13.1 shows a block diagram of the SCI.



**Figure 13.1 SCI Block Diagram**

### 13.1.3 Input/Output Pins

The SCI has serial pins for each channel as listed in table 13.1.

**Table 13.1 SCI Pins**

<b>Channel</b>	<b>Name</b>	<b>Abbreviation</b>	<b>I/O</b>	<b>Function</b>
0	Serial clock pin	SCK <sub>0</sub>	Input/output	SCI <sub>0</sub> clock input/output
	Receive data pin	RxD <sub>0</sub>	Input	SCI <sub>0</sub> receive data input
	Transmit data pin	TxD <sub>0</sub>	Output	SCI <sub>0</sub> transmit data output
1	Serial clock pin	SCK <sub>1</sub>	Input/output	SCI <sub>1</sub> clock input/output
	Receive data pin	RxD <sub>1</sub>	Input	SCI <sub>1</sub> receive data input
	Transmit data pin	TxD <sub>1</sub>	Output	SCI <sub>1</sub> transmit data output
2	Serial clock pin	SCK <sub>2</sub>	Input/output	SCI <sub>2</sub> clock input/output
	Receive data pin	RxD <sub>2</sub>	Input	SCI <sub>2</sub> receive data input
	Transmit data pin	TxD <sub>2</sub>	Output	SCI <sub>2</sub> transmit data output

### 13.1.4 Register Configuration

The SCI has internal registers as listed in table 13.2. These registers select asynchronous or synchronous mode, specify the data format and bit rate, control the transmitter and receiver sections, and specify switching between the serial communication interface and smart card interface.

**Table 13.2 SCI Registers**

Channel	Address* <sup>1</sup>	Name	Abbreviation	R/W	Initial Value
0	H'FFFB0	Serial mode register	SMR	R/W	H'00
	H'FFFB1	Bit rate register	BRR	R/W	H'FF
	H'FFFB2	Serial control register	SCR	R/W	H'00
	H'FFFB3	Transmit data register	TDR	R/W	H'FF
	H'FFFB4	Serial status register	SSR	R/(W)* <sup>2</sup>	H'84
	H'FFFB5	Receive data register	RDR	R	H'00
	H'FFFB6	Smart card mode register	SCMR	R/W	H'F2
1	H'FFFB8	Serial mode register	SMR	R/W	H'00
	H'FFFB9	Bit rate register	BRR	R/W	H'FF
	H'FFFB A	Serial control register	SCR	R/W	H'00
	H'FFFB B	Transmit data register	TDR	R/W	H'FF
	H'FFFB C	Serial status register	SSR	R/(W)* <sup>2</sup>	H'84
	H'FFFB D	Receive data register	RDR	R	H'00
	H'FFFB E	Smart card mode register	SCMR	R/W	H'F2
2	H'FFFC0	Serial mode register	SMR	R/W	H'00
	H'FFFC1	Bit rate register	BRR	R/W	H'FF
	H'FFFC2	Serial control register	SCR	R/W	H'00
	H'FFFC3	Transmit data register	TDR	R/W	H'FF
	H'FFFC4	Serial status register	SSR	R/(W)* <sup>2</sup>	H'84
	H'FFFC5	Receive data register	RDR	R	H'00
	H'FFFC6	Smart card mode register	SCMR	R/W	H'F2

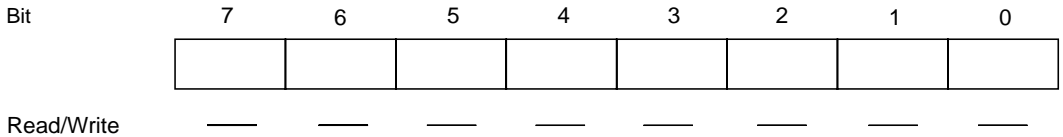
Notes: 1. Indicates the lower 20 bits of the address in advanced mode.

2. Only 0 can be written, to clear flags.

## 13.2 Register Descriptions

### 13.2.1 Receive Shift Register (RSR)

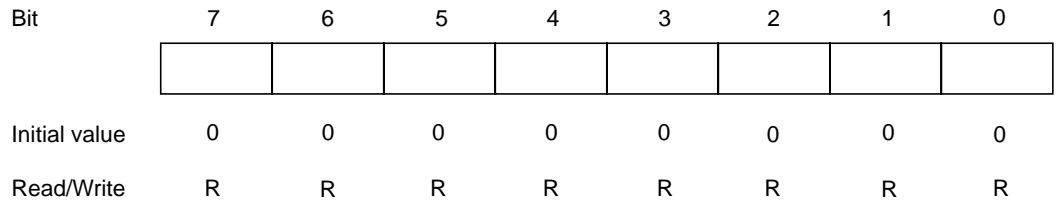
RSR is the register that receives serial data.



The SCI loads serial data input at the RxD pin into RSR in the order received, LSB (bit 0) first, thereby converting the data to parallel data. When one byte of data has been received, it is automatically transferred to RDR. The CPU cannot read or write RSR directly.

### 13.2.2 Receive Data Register (RDR)

RDR is the register that stores received serial data.

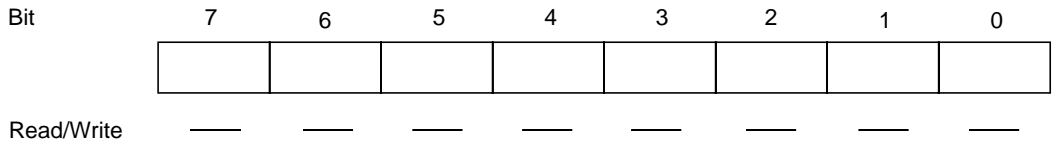


When the SCI has received one byte of serial data, it transfers the received data from RSR into RDR for storage, completing the receive operation. RSR is then ready to receive the next data. This double-buffering allows data to be received continuously.

RDR is a read-only register. Its contents cannot be modified by the CPU. RDR is initialized to H'00 by a reset and in standby mode.

### 13.2.3 Transmit Shift Register (TSR)

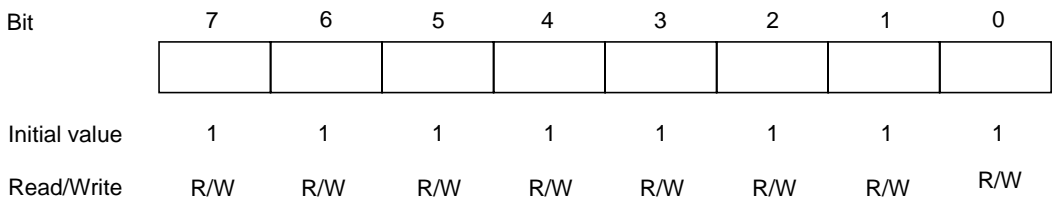
TSR is the register that transmits serial data.



The SCI loads transmit data from TDR to TSR, then transmits the data serially from the TxD pin, LSB (bit 0) first. After transmitting one data byte, the SCI automatically loads the next transmit data from TDR into TSR and starts transmitting it. If the TDRE flag is set to 1 in SSR, however, the SCI does not load the TDR contents into TSR. The CPU cannot read or write TSR directly.

### 13.2.4 Transmit Data Register (TDR)

TDR is an 8-bit register that stores data for serial transmission.

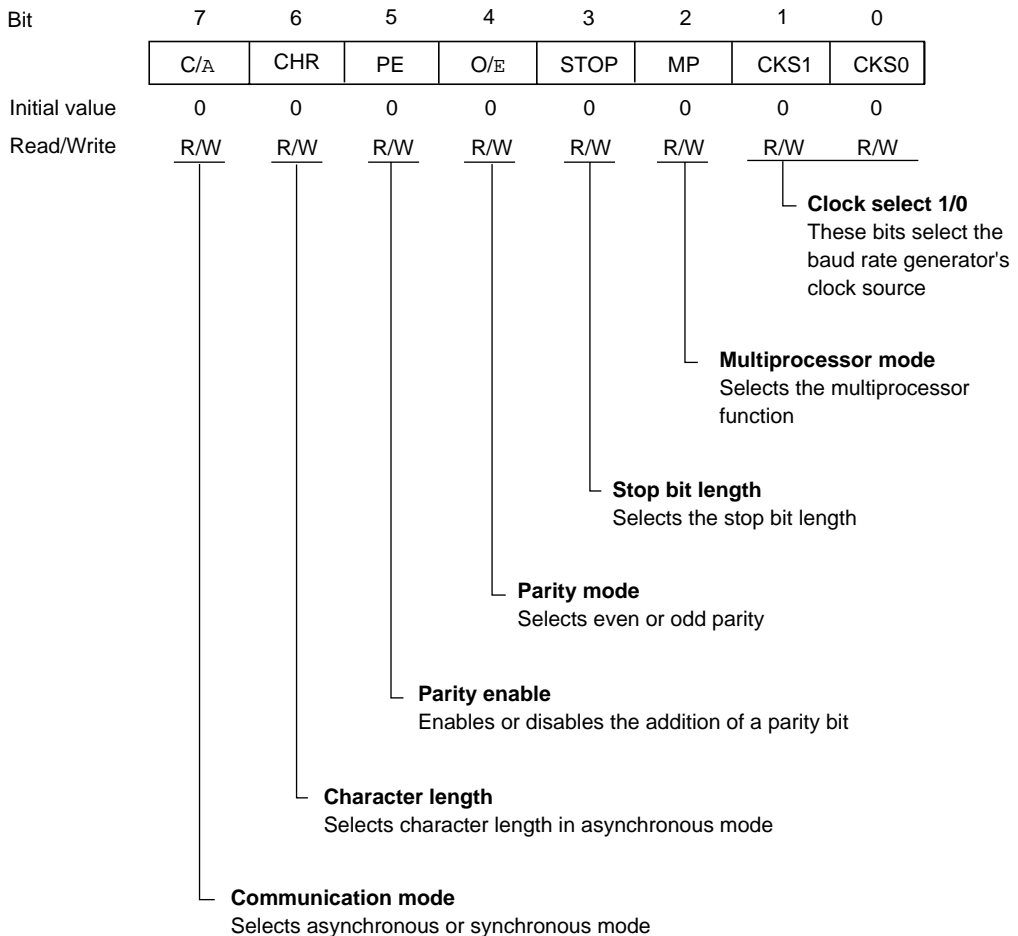


When the SCI detects that TSR is empty, it moves transmit data written in TDR from TDR into TSR and starts serial transmission. Continuous serial transmission is possible by writing the next transmit data in TDR during serial transmission from TSR.

The CPU can always read and write TDR. TDR is initialized to H'FF by a reset and in standby mode.

### 13.2.5 Serial Mode Register (SMR)

SMR is an 8-bit register that specifies the SCI's serial communication format and selects the clock source for the baud rate generator.



The CPU can always read and write SMR. SMR is initialized to H'00 by a reset and in standby mode.

**Bit 7—Communication Mode (C/A)/GSM Mode (GM):** The function of this bit differs for the normal serial communication interface and for the smart card interface. Its function is switched with the SMIF bit in SCMR.



**For serial communication interface (SMIF bit in SCMR cleared to 0):** Selects whether the SCI operates in asynchronous or synchronous mode.

**Bit 7**

<b>C/<math>\bar{A}</math></b>	<b>Description</b>	
0	Asynchronous mode	(Initial value)
1	Synchronous mode	

**For smart card interface (SMIF bit in SCMR set to 1):** Selects GSM mode for the smart card interface.

**Bit 7**

<b>GM</b>	<b>Description</b>	
0	The TEND flag is set 12.5 etu after the start bit	(Initial value)
1	The TEND flag is set 11.0 etu after the start bit	

Note: etu: Elementary time unit (time required to transmit one bit)

**Bit 6—Character Length (CHR):** Selects 7-bit or 8-bits data length in asynchronous mode. In synchronous mode, the data length is 8 bits regardless of the CHR setting,

**Bit 6**

<b>CHR</b>	<b>Description</b>	
0	8-bit data	(Initial value)
1	7-bit data*	

Note: \* When 7-bit data is selected, the MSB (bit 7) of TDR is not transmitted.

**Bit 5—Parity Enable (PE):** In asynchronous mode, this bit enables or disables the addition of a parity bit to transmit data, and the checking of the parity bit in receive data. In synchronous mode, the parity bit is neither added nor checked, regardless of the PE bit setting.

**Bit 5**

<b>PE</b>	<b>Description</b>	
0	Parity bit not added or checked	(Initial value)
1	Parity bit added and checked*	

Note: \* When PE bit is set to 1, an even or odd parity bit is added to transmit data according to the even or odd parity mode selection by the O/ $\bar{E}$  bit, and the parity bit in receive data is checked to see that it matches the even or odd mode selected by the O/ $\bar{E}$  bit.

**Bit 4—Parity Mode (O $\bar{E}$ ):** Selects even or odd parity. The O $\bar{E}$  bit setting is only valid when the PE bit is set to 1, enabling parity bit addition and checking, in asynchronous mode. The O $\bar{E}$  bit setting is ignored in synchronous mode, or when parity addition and checking is disabled in asynchronous mode.

Bit 4 O $\bar{E}$	Description	
0	Even parity* <sup>1</sup>	(Initial value)
1	Odd parity* <sup>2</sup>	

Notes: 1. When even parity is selected, the parity bit added to transmit data makes an even number of 1s in the transmitted character and parity bit combined. Receive data must have an even number of 1s in the received character and parity bit combined.

2. When odd parity is selected, the parity bit added to transmit data makes an odd number of 1s in the transmitted character and parity bit combined. Receive data must have an odd number of 1s in the received character and parity bit combined.

**Bit 3—Stop Bit Length (STOP):** Selects one or two stop bits in asynchronous mode. This setting is used only in asynchronous mode. In synchronous mod no stop bit is added, so the STOP bit setting is ignored.

Bit 3 STOP	Description	
0	1 stop bit* <sup>1</sup>	(Initial value)
1	2 stop bits* <sup>2</sup>	

Notes: 1. One stop bit (with value 1) is added to the end of each transmitted character.

2. Two stop bits (with value 1) are added to the end of each transmitted character.

In receiving, only the first stop bit is checked, regardless of the STOP bit setting. If the second stop bit is 1, it is treated as a stop bit. If the second stop bit is 0, it is treated as the start bit of the next incoming character.

**Bit 2—Multiprocessor Mode (MP):** Selects a multiprocessor format. When a multiprocessor format is selected, parity settings made by the PE and O $\bar{E}$  bits are ignored. The MP bit setting is valid only in asynchronous mode. It is ignored in synchronous mode.

For further information on the multiprocessor communication function, see section 13.3.3, Multiprocessor Communication.

Bit 2 MP	Description	
0	Multiprocessor function disabled	(Initial value)
1	Multiprocessor format selected	

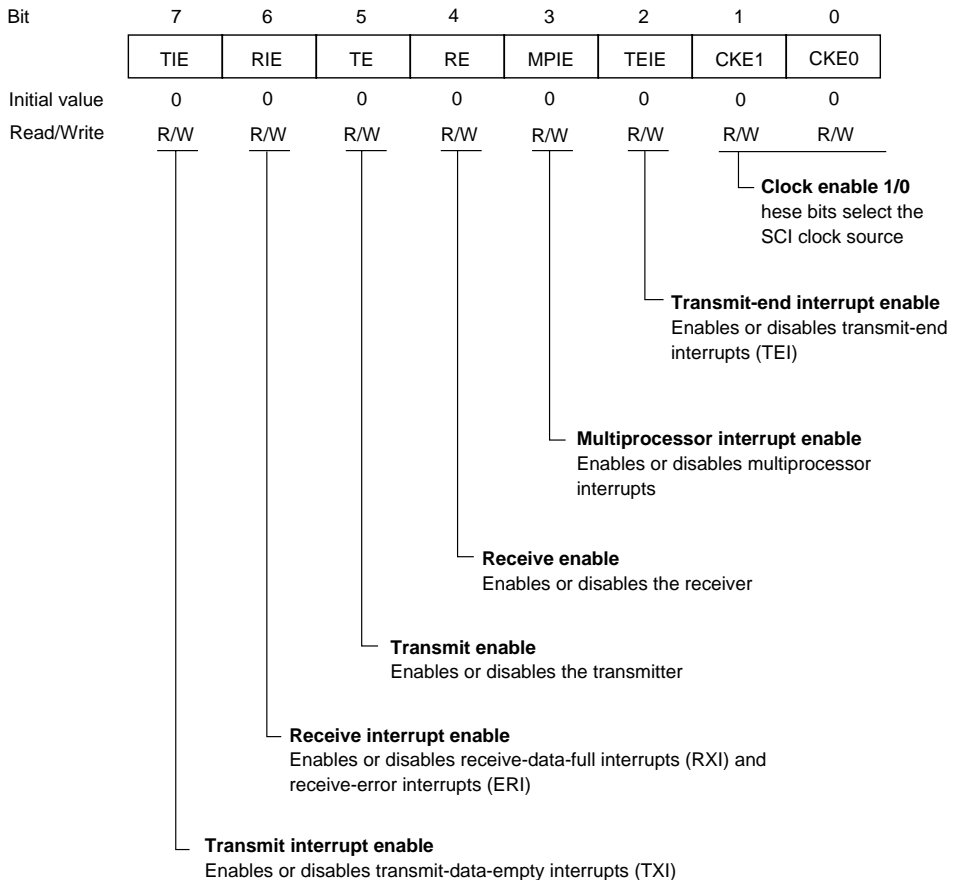
**Bits 1 and 0—Clock Select 1 and 0 (CKS1/0):** These bits select the clock source for the on-chip baud rate generator. Four clock sources are available:  $\phi$ ,  $\phi/4$ ,  $\phi/16$ , and  $\phi/64$ .

For the relationship between the clock source, bit rate register setting, and baud rate, see section 13.2.8, Bit Rate Register (BRR).

<b>Bit 1 CKS1</b>	<b>Bit 0 CKS0</b>	<b>Description</b>
0	0	$\phi$ (Initial value)
0	1	$\phi/4$
1	0	$\phi/16$
1	1	$\phi/64$

### 13.2.6 Serial Control Register (SCR)

SCR register enables or disables the SCI transmitter and receiver, enables or disables serial clock output in asynchronous mode, enables or disables interrupts, and selects the transmit/receive clock source.



The CPU can always read and write SCR. SCR is initialized to H'00 by a reset and in standby mode.

**Bit 7—Transmit Interrupt Enable (TIE):** Enables or disables the transmit-data-empty interrupt (TXI) requested when the TDRE flag in SSR is set to 1 due to transfer of serial transmit data from TDR to TSR.

**Bit 7**

TIE	Description
0	Transmit-data-empty interrupt request (TXI) is disabled* (Initial value)
1	Transmit-data-empty interrupt request (TXI) is enabled

Note: \* TXI interrupt requests can be cleared by reading the value 1 from the TDRE flag, then clearing it to 0; or by clearing the TIE bit to 0.

**Bit 6—Receive Interrupt Enable (RIE):** Enables or disables the receive-data-full interrupt (RXI) requested when the RDRF flag in SSR is set to 1 due to transfer of serial receive data from RSR to RDR; also enables or disables the receive-error interrupt (ERI).

**Bit 6**

RIE	Description
0	Receive-data-full (RXI) and receive-error (ERI) interrupt requests are disabled* (Initial value)
1	Receive-data-full (RXI) and receive-error (ERI) interrupt requests are enabled

Note: \* RXI and ERI interrupt requests can be cleared by reading the value 1 from the RDRF, FER, PER, or ORER flag, then clearing the flag to 0; or by clearing the RIE bit to 0.

**Bit 5—Transmit Enable (TE):** Enables or disables the start of SCI serial transmitting operations.

**Bit 5**

TE	Description
0	Transmitting disabled* <sup>1</sup> (Initial value)
1	Transmitting enabled* <sup>2</sup>

Notes: 1. The TDRE flag is fixed at 1 in SSR.

2. In the enabled state, serial transmission starts when the TDRE flag in SSR is cleared to 0 after writing of transmit data into TDR. Select the transmit format in SMR before setting the TE bit to 1.

**Bit 4—Receive Enable (RE):** Enables or disables the start of SCI serial receiving operations.

**Bit 4**

RE	Description	
0	Receiving disabled* <sup>1</sup>	(Initial value)
1	Receiving enabled* <sup>2</sup>	

Notes: 1. Clearing the RE bit to 0 does not affect the RDRF, FER, PER, and ORER flags. These flags retain their previous values.

2. In the enabled state, serial receiving starts when a start bit is detected in asynchronous mode, or serial clock input is detected in synchronous mode. Select the receive format in SMR before setting the RE bit to 1.

**Bit 3—Multiprocessor Interrupt Enable (MPIE):** Enables or disables multiprocessor interrupts. The MPIE bit setting is valid only in asynchronous mode, and only if the MP bit is set to 1 in SMR. The MPIE bit setting is ignored in synchronous mode or when the MP bit is cleared to 0.

**Bit 3**

MPIE	Description	
0	Multiprocessor interrupts are disabled (normal receive operation) (Initial value) Clearing conditions (1) The MPIE bit is cleared to 0 (2) MPB = 1 in received data	
1	Multiprocessor interrupts are enabled* Receive-data-full interrupts (RXI), receive-error interrupts (ERI), and setting of the RDRF, FER, and ORER status flags in SSR are disabled until data with the multiprocessor bit set to 1 is received.	

Note: \* The SCI does not transfer receive data from RSR to RDR, does not detect receive errors, and does not set the RDRF, FER, and ORER flags in SSR. When it receives data in which MPB = 1, the SCI sets the MPB bit to 1 in SSR, automatically clears the MPIE bit to 0, enables RXI and ERI interrupts (if the TIE and RIE bits in SCR are set to 1), and allows the FER and ORER flags to be set.

**Bit 2—Transmit-End interrupt Enable (TEIE):** Enables or disables the transmit-end interrupt (TEI) requested if TDR does not contain valid transmit data when the MSB is transmitted.

**Bit 2**

TEIE	Description	
0	Transmit-end interrupt requests (TEI) are disabled*	(Initial value)
1	Transmit-end interrupt requests (TEI) are enabled*	

Note: \* TEI interrupt requests can be cleared by reading the value 1 from the TDRE flag in SSR, then clearing the TDRE flag to 0, thereby also clearing the TEND flag to 0; or by clearing the TEIE bit to 0.

**Bits 1 and 0—Clock Enable 1 and 0 (CKE1/0):** The function of these bits differs for the normal serial communication interface and for the smart card interface. Their function is switched with the SMIF bit in SCMR.

**For serial communication interface (SMIF bit in SCMR cleared to 0):** These bits select the SCI clock source and enable or disable clock output from the SCK pin. Depending on the settings of CKE1 and CKE0, the SCK pin can be used for generic input/output, serial clock output, or serial clock input.

The CKE0 setting is valid only in asynchronous mode, and only when the SCI is internally clocked (CKE1 = 0). The CKE0 setting is ignored in synchronous mode, or when an external clock source is selected (CKE1 = 1). Select the SCI operating mode in SMR before setting the CKE1 and CKE0 bits. For further details on selection of the SCI clock source, see table 13.9 in section 13.3, Operation.

**Bit 1    Bit 0**

**CKE1   CKE0   Description**

0	0	Asynchronous mode	Internal clock, SCK pin available for generic input/output* <sup>1</sup>
		Synchronous mode	Internal clock, SCK pin used for serial clock output* <sup>1</sup>
0	1	Asynchronous mode	Internal clock, SCK pin used for clock output* <sup>2</sup>
		Synchronous mode	Internal clock, SCK pin used for serial clock output
1	0	Asynchronous mode	External clock, SCK pin used for clock input* <sup>3</sup>
		Synchronous mode	External clock, SCK pin used for serial clock input
1	1	Asynchronous mode	External clock, SCK pin used for clock input* <sup>3</sup>
		Synchronous mode	External clock, SCK pin used for serial clock input

Notes: 1. Initial value

2. The output clock frequency is the same as the bit rate.

3. The input clock frequency is 16 times the bit rate.

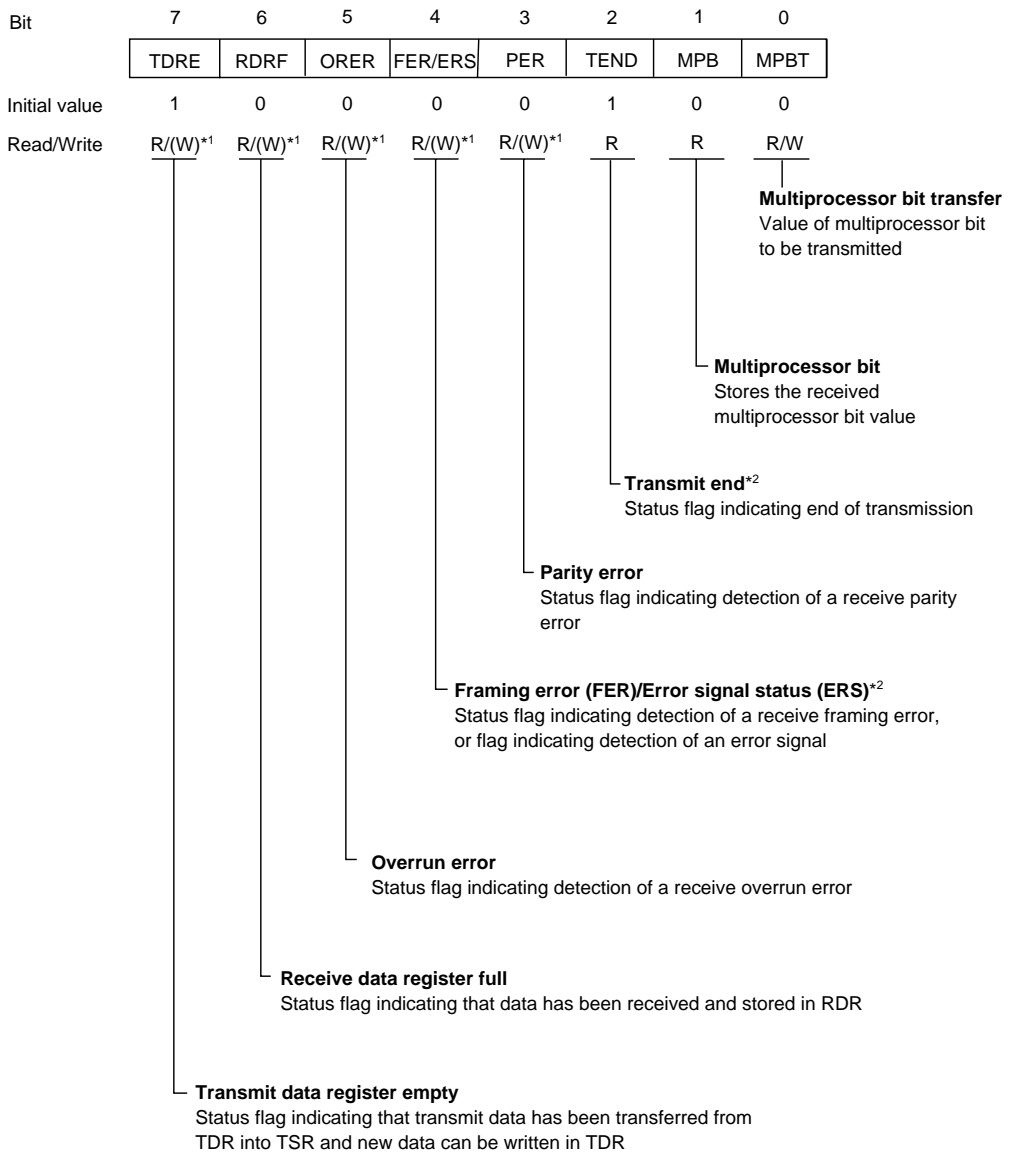
**For smart card interface (SMIF bit in SCMR set to 1):** These bits, together with the GM bit in SMR, determine whether the SCK pin is used for generic input/output or as the serial clock output pin.

<b>SMR</b>	<b>Bit 1</b>	<b>Bit 0</b>	<b>Description</b>	
<b>GM</b>	<b>CKE1</b>	<b>CKE0</b>		
0	0	0	SCK pin available for generic input/output	(Initial value)
0	0	1	SCK pin used for clock output	
1	0	0	SCK pin output fixed low	
1	0	1	SCK pin used for clock output	
1	1	0	SCK pin output fixed high	
1	1	1	SCK pin used for clock output	

### 13.2.7 Serial Status Register (SSR)

SSR is an 8-bit register containing multiprocessor bit values, and status flags that indicate the operating status of the SCI.





Notes: \*1. Only 0 can be written, to clear the flag.

\*2. Function differs between the normal serial communication interface and the smart card interface.

The CPU can always read and write SSR, but cannot write 1 in the TDRE, RDRF, ORER, PER, and FER flags. These flags can be cleared to 0 only if they have first been read while set to 1. The TEND and MPB flags are read-only bits that cannot be written.

SSR is initialized to H'84 by a reset and in standby mode.

**Bit 7—Transmit Data Register Empty (TDRE):** Indicates that the SCI has loaded transmit data from TDR into TSR and the next serial data can be written in TDR.

**Bit 7**

**TDRE**

**Description**

0	TDR contains valid transmit data Clearing conditions Read TDRE when TDRE = 1, then write 0 in TDRE The DMAC writes data in TDR	
1	TDR does not contain valid transmit data Setting conditions The chip is reset or enters standby mode The TE bit in SCR is cleared to 0 TDR contents are loaded into TSR, so new data can be written in TDR	(Initial value)

**Bit 6—Receive Data Register Full (RDRF):** Indicates that RDR contains new receive data.

**Bit 6**

**RDRF**

**Description**

0	RDR does not contain new receive data Clearing conditions The chip is reset or enters standby mode Read RDRF when RDRF = 1, then write 0 in RDRF The DMAC reads data from RDR	(Initial value)
1	RDR contains new receive data Setting condition Serial data is received normally and transferred from RSR to RDR	

**Note:** The RDR contents and the RDRF flag are not affected by detection of receive errors or by clearing of the RE bit to 0 in SCR. They retain their previous values. If the RDRF flag is still set to 1 when reception of the next data ends, an overrun error will occur and the receive data will be lost.

**Bit 5—Overrun Error (ORER):** Indicates that data reception ended abnormally due to an overrun error.

**Bit 5**

ORER	Description
0	Receiving is in progress or has ended normally* <sup>1</sup> (Initial value) Clearing conditions The chip is reset or enters standby mode Read ORER when ORER = 1, then write 0 in ORER
1	A receive overrun error occurred* <sup>2</sup> Setting condition Reception of the next serial data ends when RDRF = 1

- Notes:
1. Clearing the RE bit to 0 in SCR does not affect the ORER flag, which retains its previous value.
  2. RDR continues to hold the receive data prior to the overrun error, so subsequent receive data is lost. Serial receiving cannot continue while the ORER flag is set to 1. In synchronous mode, serial transmitting is also disabled.

**Bit 4—Framing Error (FER)/Error Signal Status (ERS):** The function of this bit differs for the normal serial communication interface and for the smart card interface. Its function is switched with the SMIF bit in SCMR.

**For serial communication interface (SMIF bit in SCMR cleared to 0):** Indicates that data reception ended abnormally due to a framing error in asynchronous mode.

**Bit 4**

FER	Description
0	Receiving is in progress or has ended normally* <sup>1</sup> (Initial value) Clearing conditions The chip is reset or enters standby mode Read FER when FER = 1, then write 0 in FER
1	A receive framing error occurred* <sup>2</sup> Setting condition The stop bit at the end of the receive data is checked and found to be 0

- Notes:
1. Clearing the RE bit to 0 in SCR does not affect the FER flag, which retains its previous value.
  2. When the stop bit length is 2 bits, only the first bit is checked. The second stop bit is not checked. When a framing error occurs the SCI transfers the receive data into RDR but does not set the RDRF flag. Serial receiving cannot continue while the FER flag is set to 1. In synchronous mode, serial transmitting is also disabled.

**For smart card interface (SMIF bit in SCMR set to 1):** Indicates the status of the error signal sent back from the receiving side during transmission. Framing errors are not detected in smart card interface mode.

**Bit 4**

ERS	Description	
0	Normal reception, no error signal* Clearing conditions The chip is reset or enters standby mode Read ERS when ERS = 1, then write 0 in ERS	(Initial value)
1	An error signal has been sent from the receiving side indicating detection of a parity error Setting condition The error signal is low when sampled	

Note: \* Clearing the TE bit to 0 in SCR does not affect the ERS flag, which retains its previous value.

**Bit 3—Parity Error (PER):** Indicates that data reception ended abnormally due to a parity error in asynchronous mode.

**Bit 3**

PER	Description	
0	Receiving is in progress or has ended normally* <sup>1</sup> Clearing conditions The chip is reset or enters standby mode Read PER when PER = 1, then write 0 in PER	(Initial value)
1	A receive parity error occurred* <sup>2</sup> Setting condition The number of 1s in receive data, including the parity bit, does not match the even or odd parity setting of O/E in SMR	

Notes: 1. Clearing the RE bit to 0 in SCR does not affect the PER flag, which retains its previous value.  
2. When a parity error occurs the SCI transfers the receive data into RDR but does not set the RDRF flag. Serial receiving cannot continue while the PER flag is set to 1. In synchronous mode, serial transmitting is also disabled.

**Bit 2—Transmit End (TEND):** The function of this bit differs for the normal serial communication interface and for the smart card interface. Its function is switched with the SMIF bit in SCMR.

**For serial communication interface (SMIF bit in SCMR cleared to 0):** Indicates that when the last bit of a serial character was transmitted TDR did not contain valid transmit data, so transmission has ended. The TEND flag is a read-only bit and cannot be written.

Bit 2 TEND	Description
0	Transmission is in progress Clearing conditions Read TDRE when TDRE = 1, then write 0 in TDRE The DMAC writes data in TDR
1	End of transmission (Initial value) Setting conditions The chip is reset or enters standby mode The TE bit in SCR is cleared to 0 TDRE is 1 when the last bit of a 1-byte serial transmit character is transmitted

**For smart card interface (SMIF bit in SCMR set to 1):** Indicates that when the last bit of a serial character was transmitted TDR did not contain valid transmit data, so transmission has ended. The TEND flag is a read-only bit and cannot be written.

Bit 2 TEND	Description
0	Transmission is in progress Clearing conditions Read TDRE when TDRE = 1, then write 0 in TDRE The DMAC writes data in TDR
1	End of transmission (Initial value) Setting conditions The chip is reset or enters standby mode The TE bit is cleared to 0 in SCR and the FER/ERS bit is also cleared to 0 TDRE is 1 and FER/ERS is 0 (normal transmission) 2.5 etu (when GM = 0) or 1.0 etu (when GM = 1) after a 1-byte serial character is transmitted

Note: etu: Elementary time unit (time required to transmit one bit)

**Bit 1—Multiprocessor bit (MPB):** Stores the value of the multiprocessor bit in the receive data when a multiprocessor format is used in asynchronous mode. MPB is a read-only bit, and cannot be written.

Bit 1 MPB	Description
0	Multiprocessor bit value in receive data is 0* (Initial value)
1	Multiprocessor bit value in receive data is 1

Note: \* If the RE bit in SCR is cleared to 0 when a multiprocessor format is selected, MPB retains its previous value.

**Bit 0—Multiprocessor Bit Transfer (MPBT):** Stores the value of the multiprocessor bit added to transmit data when a multiprocessor format is selected for transmitting in asynchronous mode.

The MPBT bit setting is ignored in synchronous mode, when a multiprocessor format is not selected, or when the SCI cannot transmit.

**Bit 1**

**MPBT**

**Description**

MPBT	Description
0	Multiprocessor bit value in transmit data is 0 (Initial value)
1	Multiprocessor bit value in transmit data is 1

### 13.2.8 Bit Rate Register (BRR)

BRR is an 8-bit register that, together with the CKS1 and CKS0 bits in SMR that select the baud rate generator clock source, determines the serial communication bit rate.

Bit	7	6	5	4	3	2	1	0
Initial value	1	1	1	1	1	1	1	1
Read/Write	R/W	R/W	R/W	R/W	R/W	R/W	R/W	R/W

The CPU can always read and write BRR. BRR is initialized to H'FF by a reset and in standby mode. Each SCI channel has independent baud rate generator control, so different values can be set in the three channels.

Table 13.3 shows examples of BRR settings in asynchronous mode. Table 13.4 shows examples of BRR settings in synchronous mode.

**Table 13.3 Examples of Bit Rates and BRR Settings in Asynchronous Mode**

Bit Rate (bit/s)	$\phi$ (MHz)											
	2			2.097152			2.4576			3		
	n	N	Error (%)	n	N	Error (%)	n	N	Error (%)	n	N	Error (%)
110	1	141	0.03	1	148	-0.04	1	174	-0.26	1	212	0.03
150	1	103	0.16	1	108	0.21	1	127	0.00	1	155	0.16
300	0	207	0.16	0	217	0.21	0	255	0.00	1	77	0.16
600	0	103	0.16	0	108	0.21	0	127	0.00	0	155	0.16
1200	0	51	0.16	0	54	-0.70	0	63	0.00	0	77	0.16
2400	0	25	0.16	0	26	1.14	0	31	0.00	0	38	0.16
4800	0	12	0.16	0	13	-2.48	0	15	0.00	0	19	-2.34
9600	0	6	-6.99	0	6	-2.48	0	7	0.00	0	9	-2.34
19200	0	2	8.51	0	2	13.78	0	3	0.00	0	4	-2.34
31250	0	1	0.00	0	1	4.86	0	1	22.88	0	2	0.00
38400	0	1	-18.62	0	1	-14.67	0	1	0.00	—	—	—

**Table 13.3 Examples of Bit Rates and BRR Settings in Asynchronous Mode (cont)**

Bit Rate (bit/s)	$\phi$ (MHz)											
	3.6864			4			4.9152			5		
	n	N	Error (%)	n	N	Error (%)	n	N	Error (%)	n	N	Error (%)
110	2	64	0.07	2	70	0.03	2	86	0.31	2	88	-0.25
150	1	191	0.00	1	207	0.16	1	255	0.00	2	64	0.16
300	1	95	0.00	1	103	0.16	1	127	0.00	1	129	0.16
600	0	191	0.00	0	207	0.16	0	255	0.00	1	64	0.16
1200	0	95	0.00	0	103	0.16	0	127	0.00	0	129	0.16
2400	0	47	0.00	0	51	0.16	0	63	0.00	0	64	0.16
4800	0	23	0.00	0	25	0.16	0	31	0.00	0	32	-1.36
9600	0	11	0.00	0	12	0.16	0	15	0.00	0	15	1.73
19200	0	5	0.00	0	6	-6.99	0	7	0.00	0	7	1.73
31250	—	—	—	0	3	0.00	0	4	-1.70	0	4	0.00
38400	0	2	0.00	0	2	8.51	0	3	0.00	0	3	1.73

Bit Rate (bit/s)	$\phi$ (MHz)											
	6			6.144			7.3728			8		
	n	N	Error (%)	n	N	Error (%)	n	N	Error (%)	n	N	Error (%)
110	2	106	-0.44	2	108	0.08	2	130	-0.07	2	141	0.03
150	2	77	0.16	2	79	0.00	2	95	0.00	2	103	0.16
300	1	155	0.16	1	159	0.00	1	191	0.00	1	207	0.16
600	1	77	0.16	1	79	0.00	1	95	0.00	1	103	0.16
1200	0	155	0.16	0	159	0.00	0	191	0.00	0	207	0.16
2400	0	77	0.16	0	79	0.00	0	95	0.00	0	103	0.16
4800	0	38	0.16	0	39	0.00	0	47	0.00	0	51	0.16
9600	0	19	-2.34	0	19	0.00	0	23	0.00	0	25	0.16
19200	0	9	-2.34	0	9	0.00	0	11	0.00	0	12	0.16
31250	0	5	0.00	0	5	2.40	0	6	5.33	0	7	0.00
38400	0	4	-2.34	0	4	0.00	0	5	0.00	0	6	-6.99



**Table 13.3 Examples of Bit Rates and BRR Settings in Asynchronous Mode (cont)**

Bit Rate (bit/s)	$\phi$ (MHz)											
	9.8304			10			12			12.288		
	n	N	Error (%)	n	N	Error (%)	n	N	Error (%)	n	N	Error (%)
110	2	174	-0.26	2	177	-0.25	2	212	0.03	2	217	0.08
150	2	127	0.00	2	129	0.16	2	155	0.16	2	159	0.00
300	1	255	0.00	2	64	0.16	2	77	0.16	2	79	0.00
600	1	127	0.00	1	129	0.16	1	155	0.16	1	159	0.00
1200	0	255	0.00	1	64	0.16	1	77	0.16	1	79	0.00
2400	0	127	0.00	0	129	0.16	0	155	0.16	0	159	0.00
4800	0	63	0.00	0	64	0.16	0	77	0.16	0	79	0.00
9600	0	31	0.00	0	32	-1.36	0	38	0.16	0	39	0.00
19200	0	15	0.00	0	15	1.73	0	19	-2.34	0	19	0.00
31250	0	9	-1.70	0	9	0.00	0	11	0.00	0	11	2.40
38400	0	7	0.00	0	7	1.73	0	9	-2.34	0	9	0.00

Bit Rate (bit/s)	$\phi$ (MHz)																	
	13			14			14.7456			16			18			20		
	n	N	Error (%)	n	N	Error (%)	n	N	Error (%)	n	N	Error (%)	n	N	Error (%)	n	N	Error (%)
110	2	230	-0.08	2	248	-0.17	3	64	0.70	3	70	0.03	3	79	-0.12	3	88	-0.25
150	2	168	0.16	2	181	0.16	2	191	0.00	2	207	0.16	2	233	0.16	3	64	0.16
300	2	84	-0.43	2	90	0.16	2	95	0.00	2	103	0.16	2	116	0.16	2	129	0.16
600	1	168	0.16	1	181	0.16	1	191	0.00	1	207	0.16	1	233	0.16	2	64	0.16
1200	1	84	-0.43	1	90	0.16	1	95	0.00	1	103	0.16	1	116	0.16	1	129	0.16
2400	0	168	0.16	0	181	0.16	0	191	0.00	0	207	0.16	0	233	0.16	1	64	0.16
4800	0	84	-0.43	0	90	0.16	0	95	0.00	0	103	0.16	0	116	0.16	0	129	0.16
9600	0	41	0.76	0	45	-0.93	0	47	0.00	0	51	0.16	0	58	-0.69	0	64	0.16
19200	0	20	0.76	0	22	-0.93	0	23	0.00	0	25	0.16	0	28	1.02	0	32	-1.36
31250	0	12	0.00	0	13	0.00	0	14	-1.70	0	15	0.00	0	17	0.00	0	19	0.00
38400	0	10	-3.82	0	10	3.57	0	11	0.00	0	12	0.16	0	14	-2.34	0	15	1.73

**Table 13.4 Examples of Bit Rates and BRR Settings in Synchronous Mode**

Bit Rate (bit/s)	$\phi$ (MHz)															
	2		4		8		10		13		16		18		20	
	n	N	n	N	n	N	n	N	n	N	n	N	n	N	n	N
110	3	70	—	—	—	—	—	—	—	—	—	—	—	—	—	—
250	2	124	2	249	3	124	—	—	3	202	3	249	—	—	—	—
500	1	249	2	124	2	249	—	—	3	101	3	124	3	140	3	155
1k	1	124	1	249	2	124	—	—	2	202	2	249	3	69	3	77
2.5k	0	199	1	99	1	199	1	249	2	80	2	99	2	112	2	124
5k	0	99	0	199	1	99	1	124	1	162	1	199	1	224	1	249
10k	0	49	0	99	0	199	0	249	1	80	1	99	1	112	1	124
25k	0	19	0	39	0	79	0	99	0	129	0	159	0	179	0	199
50k	0	9	0	19	0	39	0	49	0	64	0	79	0	89	0	99
100k	0	4	0	9	0	19	0	24	—	—	0	39	0	44	0	49
250k	0	1	0	3	0	7	0	9	0	12	0	15	0	17	0	19
500k	0	0*	0	1	0	3	0	4	—	—	0	7	0	8	0	9
1M			0	0*	0	1	—	—	—	—	0	3	0	4	0	4
2M					0	0*	—	—	—	—	0	1	—	—	—	—
2.5M					—	—	0	0*	—	—	—	—	—	—	—	—
4M											0	0*	—	—	—	—

Note: Settings with an error of 1% or less are recommended.

### Legend

Blank : No setting available

— : Setting possible, but error occurs

\* : Continuous transmission/reception not possible

The BRR setting is calculated as follows:

**Asynchronous mode:**

$$N = \frac{\phi}{64 \times 2^{2n-1} \times B} \times 10^6 - 1$$

**Synchronous mode:**

$$N = \frac{\phi}{8 \times 2^{2n-1} \times B} \times 10^6 - 1$$

B: Bit rate (bit/s)

N: BRR setting for baud rate generator (0 N 255)

$\phi$ : System clock frequency (MHz)

n: Baud rate generator clock source (n = 0, 1, 2, 3)

(For the clock sources and values of n, see the following table.)

n	Clock Source	SMR Settings	
		CKS1	CKS0
0	$\phi$	0	0
1	$\phi/4$	0	1
2	$\phi/16$	1	0
3	$\phi/64$	1	1

The bit rate error in asynchronous mode is calculated as follows:

$$\text{Error (\%)} = \left\{ \frac{\phi \times 10^6}{(N + 1) \times B \times 64 \times 2^{2n-1}} - 1 \right\} \times 100$$

Table 13.5 shows the maximum bit rates in asynchronous mode for various system clock frequencies. Table 13.6 and 13.7 shows the maximum bit rates with external clock input.

**Table 13.5 Maximum Bit Rates for Various Frequencies (Asynchronous Mode)**

$\phi$ (MHz)	Maximum Bit Rate (bit/s)	Settings	
		n	N
2	62500	0	0
2.097152	65536	0	0
2.4576	76800	0	0
3	93750	0	0
3.6864	115200	0	0
4	125000	0	0
4.9152	153600	0	0
5	156250	0	0
6	187500	0	0
6.144	192000	0	0
7.3728	230400	0	0
8	250000	0	0
9.8304	307200	0	0
10	312500	0	0
12	375000	0	0
12.288	384000	0	0
14	437500	0	0
14.7456	460800	0	0
16	500000	0	0
17.2032	537600	0	0
18	562500	0	0
20	625000	0	0

**Table 13.6 Maximum Bit Rates with External Clock Input (Asynchronous Mode)**

$\phi$ (MHz)	External Input Clock (MHz)	Maximum Bit Rate (bit/s)
2	0.5000	31250
2.097152	0.5243	32768
2.4576	0.6144	38400
3	0.7500	46875
3.6864	0.9216	57600
4	1.0000	62500
4.9152	1.2288	76800
5	1.2500	78125
6	1.5000	93750
6.144	1.5360	96000
7.3728	1.8432	115200
8	2.0000	125000
9.8304	2.4576	153600
10	2.5000	156250
12	3.0000	187500
12.288	3.0720	192000
14	3.5000	218750
14.7456	3.6864	230400
16	4.0000	250000
17.2032	4.3008	268800
18	4.5000	281250
20	5.0000	312500

**Table 13.7 Maximum Bit Rates with External Clock Input (Synchronous Mode)**

$\phi$ (MHz)	External Input Clock (MHz)	Maximum Bit Rate (bit/s)
2	0.3333	333333.3
4	0.6667	666666.7
6	1.0000	1000000.0
8	1.3333	1333333.3
10	1.6667	1666666.7
12	2.0000	2000000.0
14	2.3333	2333333.3
16	2.6667	2666666.7
18	3.0000	3000000.0
20	3.3333	3333333.3

## 13.3 Operation

### 13.3.1 Overview

The SCI can carry out serial communication in two modes: asynchronous mode in which synchronization is achieved character by character, and synchronous mode in which synchronization is achieved with clock pulses. A smart card interface is also supported as a serial communication function for an IC card interface.

Selection of asynchronous or synchronous mode and the transmission format for the normal serial communication interface is made in SMR, as shown in table 13.8. The SCI clock source is selected by the  $C/\bar{A}$  bit in SMR and the CKE1 and CKE0 bits in SCR, as shown in table 13.9.

For details of the procedures for switching between LSB-first and MSB-first mode and inverting the data logic level, see section 14.2.1, Smart Card Mode Register (SCMR).

For selection of the smart card interface format, see section 14.3.3, Data Format.

#### Asynchronous Mode

- Data length is selectable: 7 or 8 bits
- Parity and multiprocessor bits are selectable, and so is the stop bit length (1 or 2 bits). These selections determine the communication format and character length.
- In receiving, it is possible to detect framing errors, parity errors, overrun errors, and the break state.
- An internal or external clock can be selected as the SCI clock source.
  - When an internal clock is selected, the SCI operates using the on-chip baud rate generator, and can output a serial clock signal with a frequency matching the bit rate.
  - When an external clock is selected, the external clock input must have a frequency 16 times the bit rate. (The on-chip baud rate generator is not used.)

#### Synchronous Mode

- The communication format has a fixed 8-bit data length.
- In receiving, it is possible to detect overrun errors.
- An internal or external clock can be selected as the SCI clock source.
  - When an internal clock is selected, the SCI operates using the on-chip baud rate generator, and can output a serial clock signal to external devices.
  - When an external clock is selected, the SCI operates on the input serial clock. The on-chip baud rate generator is not used.

## Smart Card Interface

- One frame consists of 8-bit data and a parity bit.
- In transmitting, a guard time of at least two elementary time units (2 etu) is provided between the end of the parity bit and the start of the next frame. (An elementary time unit is the time required to transmit one bit.)
- In receiving, if a parity error is detected, a low error signal level is output for 1 etu, beginning 10.5 etu after the start bit..
- In transmitting, if an error signal is received, the same data is automatically transmitted again after at least 2 etu.
- Only asynchronous communication is supported. There is no synchronous communication function.

For details of smart card interface operation, see section 14, Smart Card Interface.

**Table 13.8 SMR Settings and Serial Communication Formats**

SMR Settings						SCI Communication Format												
Bit 7 C/A	Bit 6 CHR	Bit 2 MP	Bit 5 PE	Bit 3 STOP	Mode	Data Length	Multi- pro- cessor Bit	Parity Bit	Stop Bit Length									
0	0	0	0	0	Asyn- chronous mode	8-bit data	Absent	Absent	1 bit									
				1					2 bits									
				0	mode				8-bit data	Absent	Present	1 bit						
				1								2 bits						
				1	0							7-bit data	Absent	Absent	1 bit			
				1											2 bits			
	1	0	7-bit data	Present	Present	1 bit												
	1					2 bits												
	0	1				—	—	0	Asyn- chronous mode (multi- processor format)	8-bit data	Present				Absent	1 bit		
								1								2 bits		
								1	0			7-bit data	Absent	Absent		1 bit		
								1								2 bits		
1			—	—	—			—	Syn- chronous mode							8-bit data	Absent	None



**Table 13.9 SMR and SCR Settings and SCI Clock Source Selection**

SMR Bit 7 C/A	SCR Setting			SCI Transmit/Receive clock	
	Bit 1 CKE1	Bit 0 CKE0	Mode	Clock Source	SCK Pin Function
0	0	0	Asynchronous mode	Internal	SCI does not use the SCK pin
		1			Outputs clock with frequency matching the bit rate
	1	0		External	Inputs clock with frequency 16 times the bit rate
		1			
1	0	0	Synchronous mode	Internal	Outputs the serial clock
		1			
	1	0		External	Inputs the serial clock
		1			

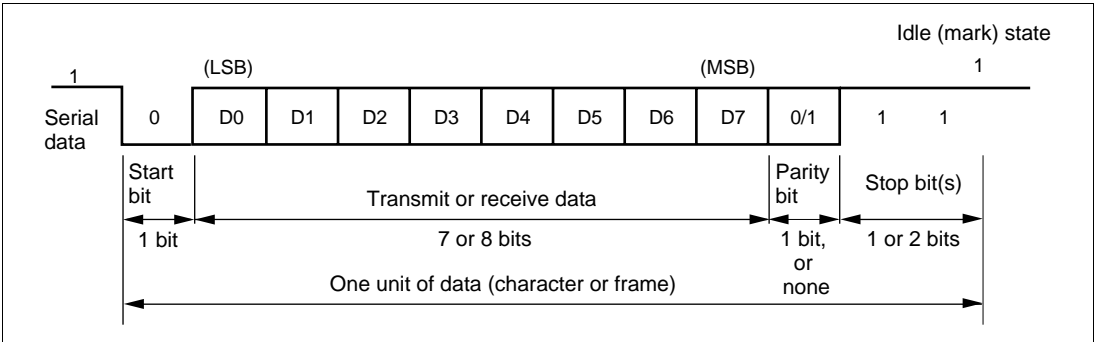
### 13.3.2 Operation in Asynchronous Mode

In asynchronous mode, each transmitted or received character begins with a start bit and ends with one or two stop bits. Serial communication is synchronized one character at a time.

The transmitting and receiving sections of the SCI are independent, so full-duplex communication is possible. The transmitter and the receiver are both double-buffered, so data can be written and read while transmitting and receiving are in progress, enabling continuous transmitting and receiving.

Figure 13.2 shows the general format of asynchronous serial communication. In asynchronous serial communication the communication line is normally held in the mark (high) state. The SCI monitors the line and starts serial communication when the line goes to the space (low) state, indicating a start bit. One serial character consists of a start bit (low), data (LSB first), parity bit (high or low), and one or two stop bits (high), in that order.

When receiving in asynchronous mode, the SCI synchronizes at the falling edge of the start bit. The SCI samples each data bit on the eighth pulse of a clock with a frequency 16 times the bit rate. Receive data is latched at the center of each bit.



**Figure 13.2 Data Format in Asynchronous Communication  
(Example: 8-Bit Data with Parity and 2 Stop Bits)**

**Communication Formats:** Table 13.10 shows the 12 communication formats that can be selected in asynchronous mode. The format is selected by settings in SMR.

**Table 13.10 Serial Communication Formats (Asynchronous Mode)**

SMR Settings				Serial Communication Format and Frame Length													
CHR	PE	MP	STOP	1	2	3	4	5	6	7	8	9	10	11	12		
0	0	0	0	S	8-bit data								STOP				
0	0	0	1	S	8-bit data								STOP	STOP			
0	1	0	0	S	8-bit data								P	STOP			
0	1	0	1	S	8-bit data								P	STOP	STOP		
1	0	0	0	S	7-bit data							STOP					
1	0	0	1	S	7-bit data							STOP	STOP				
1	1	0	0	S	7-bit data							P	STOP				
1	1	0	1	S	7-bit data							P	STOP	STOP			
0	—	1	0	S	8-bit data								MPB	STOP			
0	—	1	1	S	8-bit data								MPB	STOP	STOP		
1	—	1	0	S	7-bit data							MPB	STOP				
1	—	1	1	S	7-bit data							MPB	STOP	STOP			

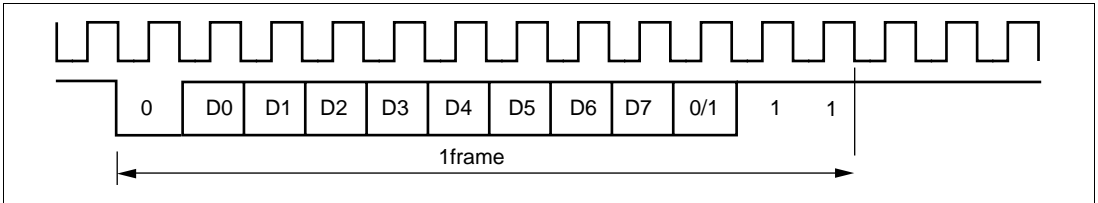
**Legend**

- S: Start bit
- STOP: Stop bit
- P: Parity bit
- MPB: Multiprocessor bit

**Clock:** An internal clock generated by the on-chip baud rate generator or an external clock input from the SCK pin can be selected as the SCI transmit/receive clock. The clock source is selected by the  $C/\overline{A}$  bit in SMR and bits CKE1 and CKE0 in SCR. For details of SCI clock source selection, see table 13.9.

When an external clock is input at the SCK pin, it must have a frequency 16 times the desired bit rate.

When the SCI is operated on an internal clock, it can output a clock signal at the SCK pin. The frequency of this output clock is equal to the bit rate. The phase is aligned as shown in figure 13.3 so that the rising edge of the clock occurs at the center of each transmit data bit.



**Figure 13.3 Phase Relationship between Output Clock and Serial Data (Asynchronous Mode)**

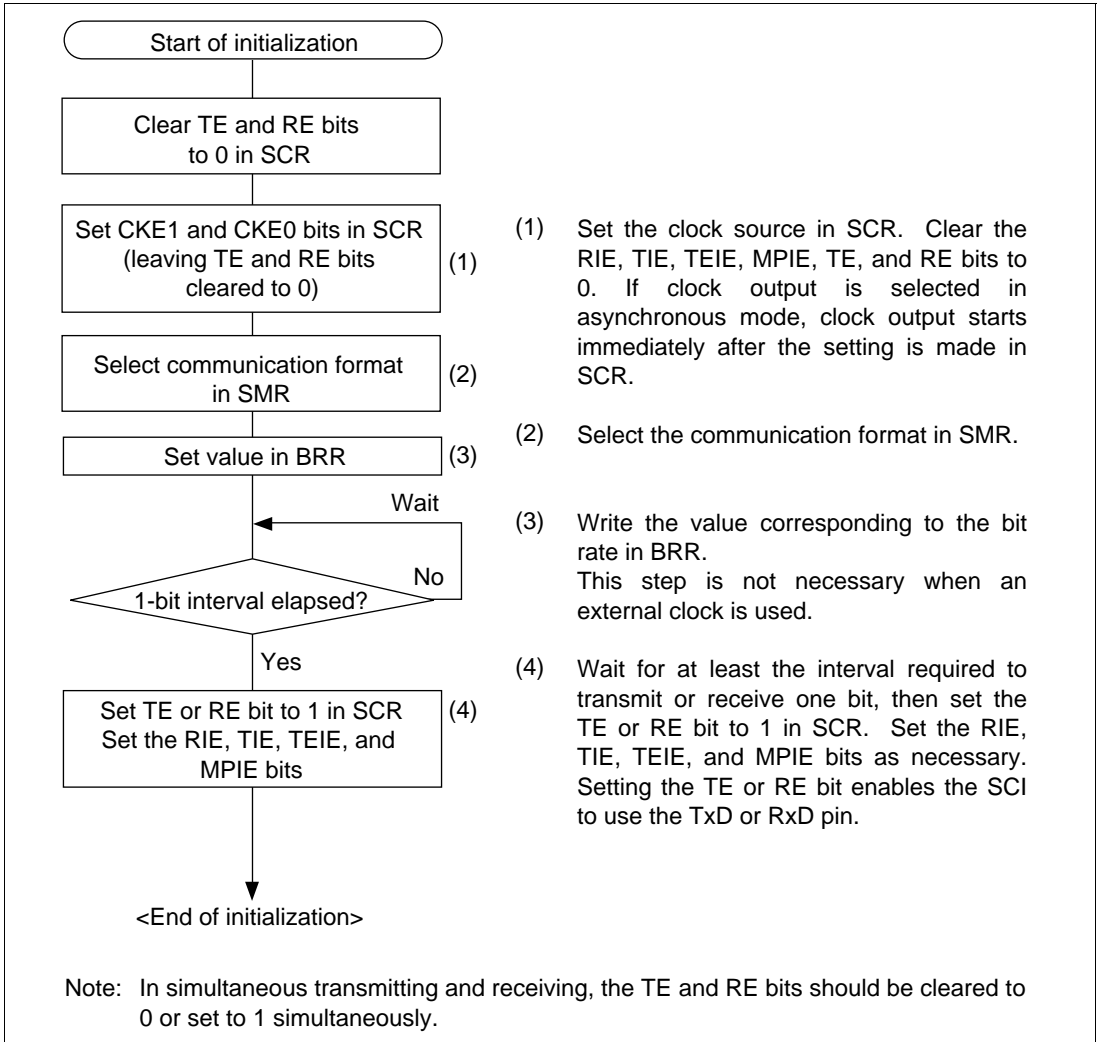
#### **Transmitting and Receiving Data:**

- **SCI Initialization (Asynchronous Mode):** Before transmitting or receiving data, clear the TE and RE bits to 0 in SCR, then initialize the SCI as follows.

When changing the communication mode or format, always clear the TE and RE bits to 0 before following the procedure given below. Clearing TE to 0 sets the TDRE flag to 1 and initializes TSR. Clearing RE to 0, however, does not initialize the RDRF, PER, FER, and ORER flags, or RDR, which retain their previous contents.

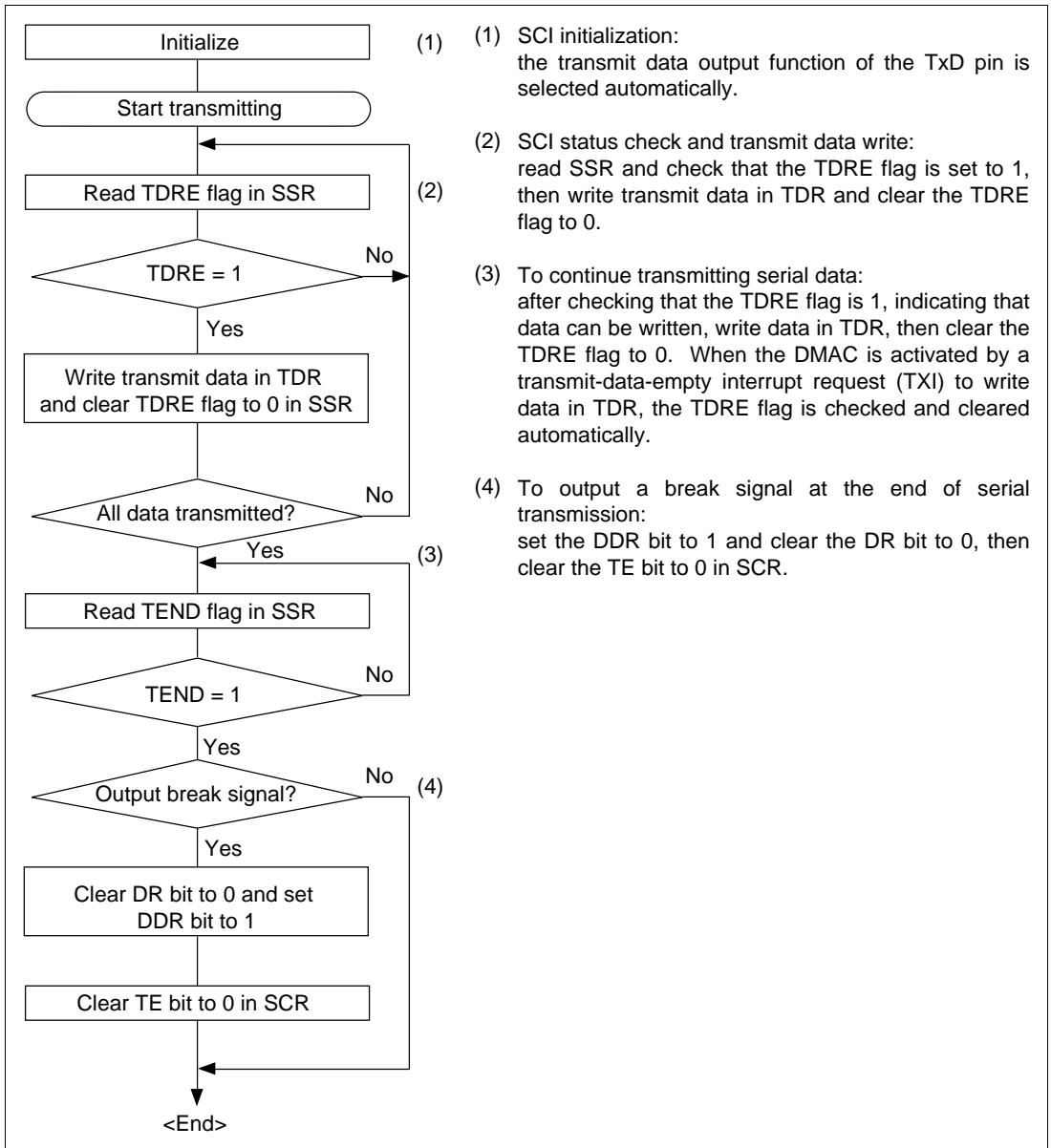
When an external clock is used the clock should not be stopped during initialization or subsequent operation, since operation will be unreliable in this case.

Figure 13.4 shows a sample flowchart for initializing the SCI.



**Figure 13.4 Sample Flowchart for SCI Initialization**

- **Transmitting Serial Data (Asynchronous Mode):** Figure 13.5 shows a sample flowchart for transmitting serial data and indicates the procedure to follow.



**Figure 13.5 Sample Flowchart for Transmitting Serial Data**

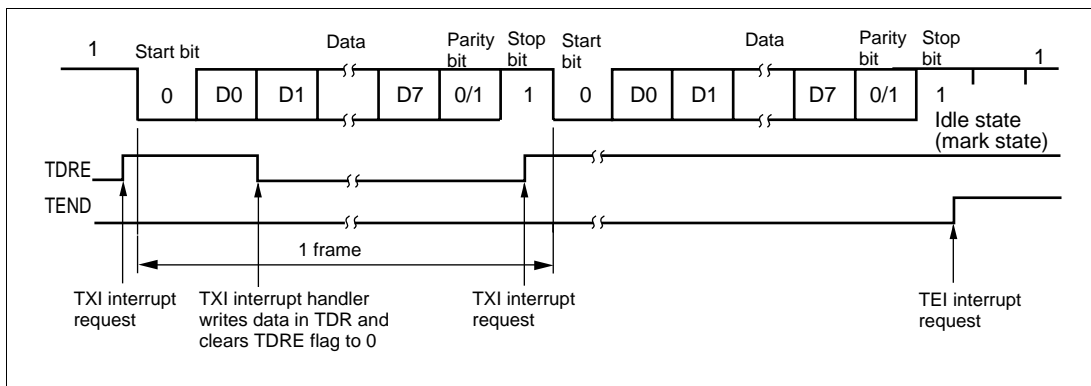
In transmitting serial data, the SCI operates as follows:

- The SCI monitors the TDRE flag in SSR. When the TDRE flag is cleared to 0, the SCI recognizes that TDR contains new data, and loads this data from TDR into TSR.
- After loading the data from TDR to TSR, the SCI sets the TDRE flag to 1 and starts transmitting. If the TIE bit is set to 1 in SCR, the SCI requests a transmit-data-empty interrupt (TXI) at this time.

Serial transmit data is transmitted in the following order from the TxD pin:

- Start bit: One 0 bit is output.
- Transmit data: 7 or 8 bits are output, LSB first.
- Parity bit or multiprocessor bit: One parity bit (even or odd parity), or one multiprocessor bit is output. Formats in which neither a parity bit nor a multiprocessor bit is output can also be selected.
- Stop bit(s): One or two 1 bits (stop bits) are output.
- Mark state: Output of 1 bits continues until the start bit of the next transmit data.
- The SCI checks the TDRE flag when it outputs the stop bit. If the TDRE flag is 0, the SCI loads new data from TDR into TSR, outputs the stop bit, then begins serial transmission of the next frame. If the TDRE flag is 1, the SCI sets the TEND flag to 1 in SSR, outputs the stop bit, then continues output of 1 bits in the mark state. If the TEIE bit is set to 1 in SCR, a transmit-end interrupt (TEI) is requested at this time

Figure 13.6 shows an example of SCI transmit operation in asynchronous mode.



**Figure 13.6 Example of SCI Transmit Operation in Asynchronous Mode (8-Bit Data with Parity and One Stop Bit)**

- Receiving Serial Data (Asynchronous Mode): Figure 13.7 shows a sample flowchart for receiving serial data and indicates the procedure to follow.

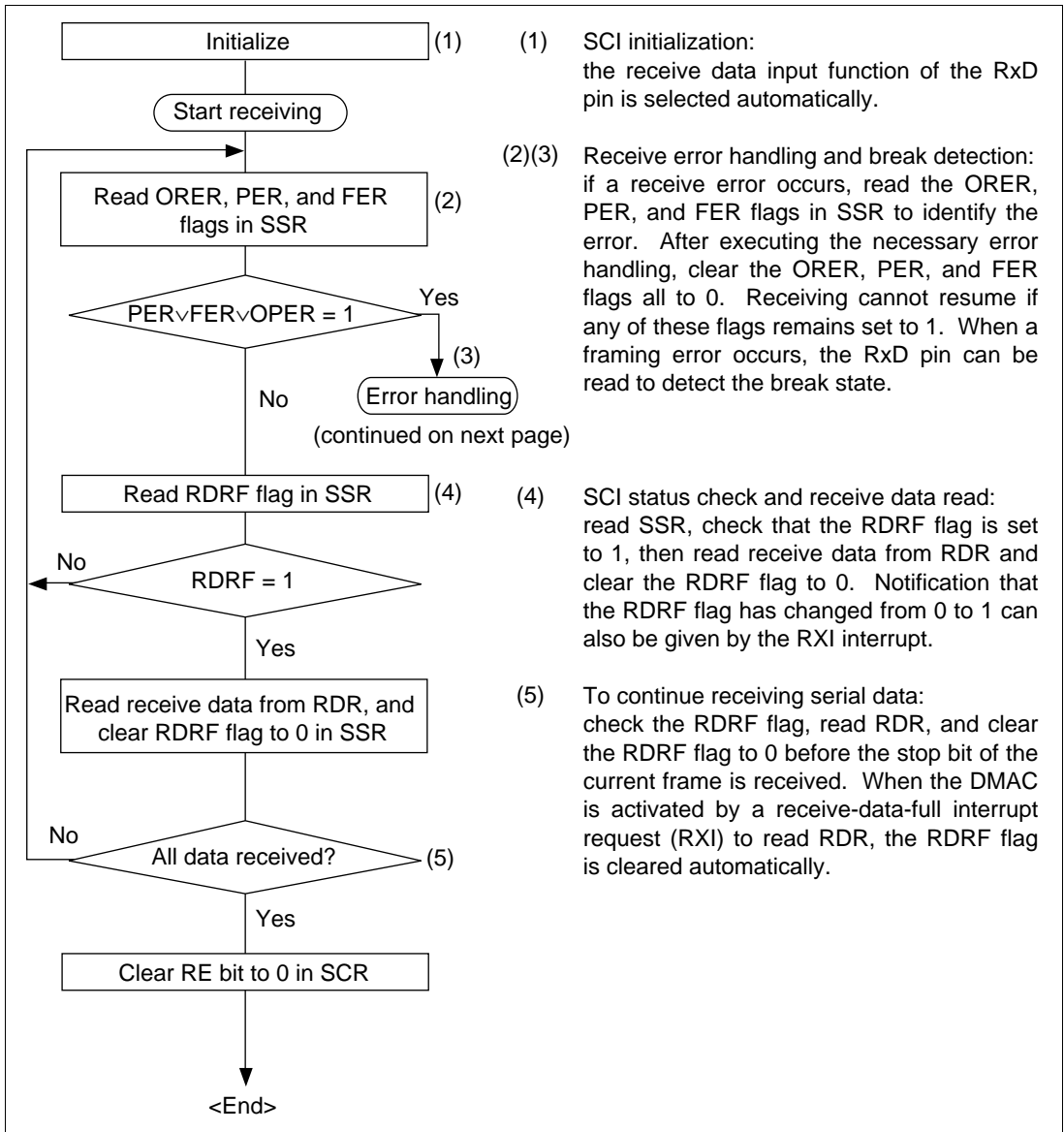
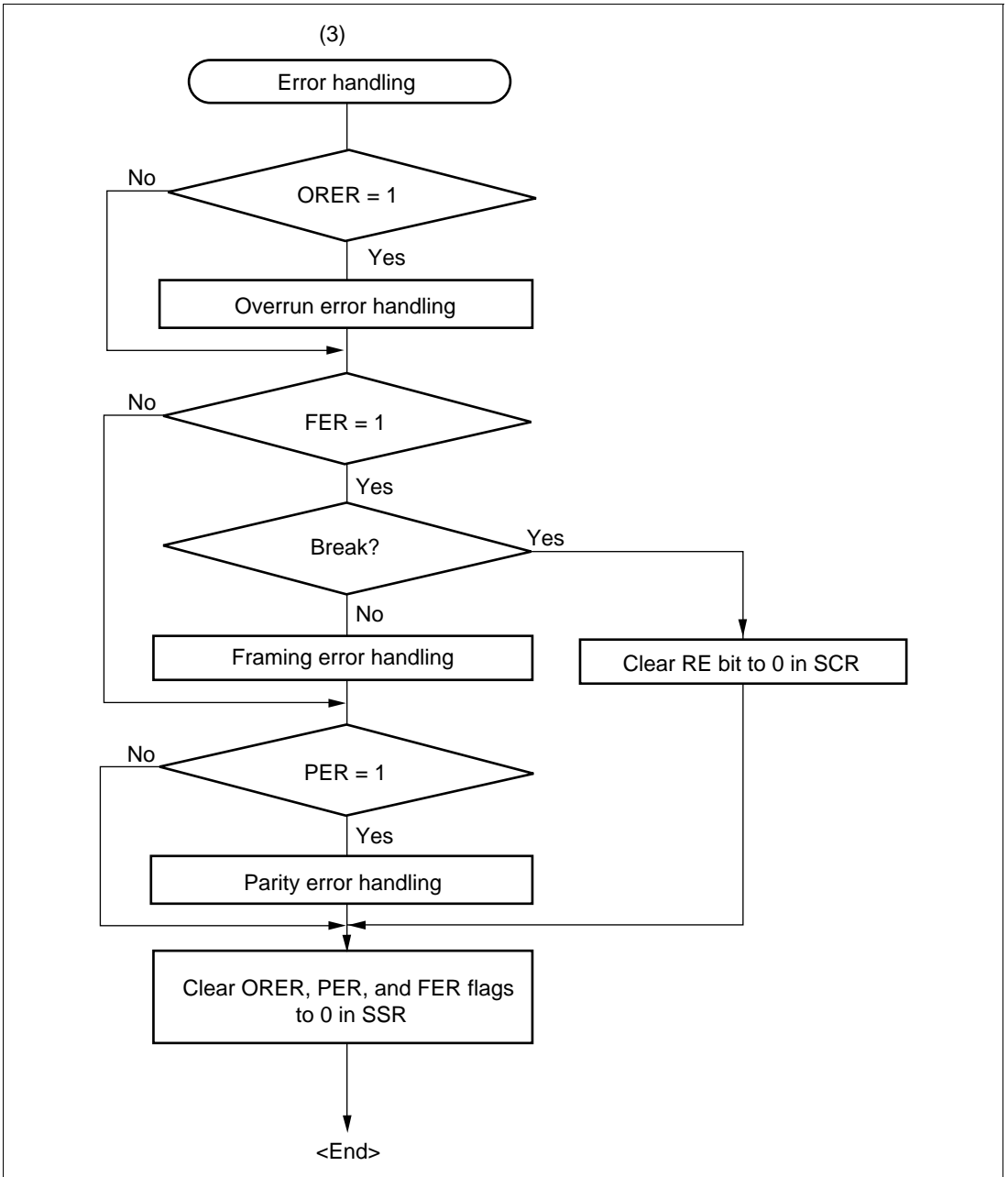


Figure 13.7 Sample Flowchart for Receiving Serial Data (1)





**Figure 13.7 Sample Flowchart for Receiving Serial Data (2)**

In receiving, the SCI operates as follows:

- The SCI monitors the communication line. When it detects a start bit (0 bit), the SCI synchronizes internally and starts receiving.
  - Receive data is stored in RSR in order from LSB to MSB.
  - The parity bit and stop bit are received.
- After receiving these bits, the SCI carries out the following checks:
- Parity check: The number of 1s in the receive data must match the even or odd parity setting of in the  $O/\bar{E}$  bit in SMR.
  - Stop bit check: The stop bit value must be 1. If there are two stop bits, only the first is checked.
  - Status check: The RDRF flag must be 0, indicating that the receive data can be transferred from RSR into RDR.

If these all checks pass, the RDRF flag is set to 1 and the received data is stored in RDR. If one of the checks fails (receive error\*), the SCI operates as shown in table 13.11.

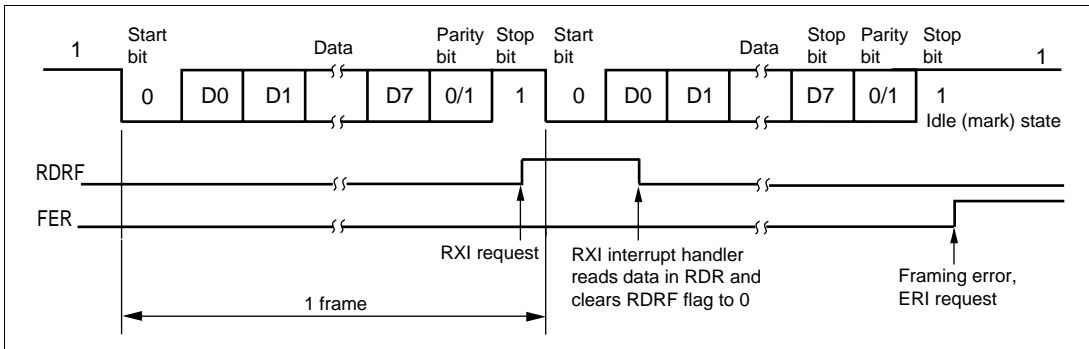
Note: \* When a receive error occurs, further receiving is disabled. In receiving, the RDRF flag is not set to 1. Be sure to clear the error flags to 0.

- When the RDRF flag is set to 1, if the RIE bit is set to 1 in SCR, a receive-data-full interrupt (RXI) is requested. If the ORER, PER, or FER flag is set to 1 and the RIE bit in SCR is also set to 1, a receive-error interrupt (ERI) is requested.

**Table 13.11 Receive Error Conditions**

Receive Error	Abbreviation	Condition	Data Transfer
Overflow error	ORER	Receiving of next data ends while RDRF flag is still set to 1 in SSR	Receive data is not transferred from RSR to RDR
Framing error	FER	Stop bit is 0	Receive data is transferred from RSR to RDR
Parity error	PER	Parity of received data differs from even/odd parity setting in SMR	Receive data is transferred from RSR to RDR

Figure 13.8 shows an example of SCI receive operation in asynchronous mode.



**Figure 13.8 Example of SCI Receive Operation  
(8-Bit Data with Parity and One Stop Bit)**

### 13.3.3 Multiprocessor Communication

The multiprocessor communication function enables several processors to share a single serial communication line. The processors communicate in asynchronous mode using a format with an additional multiprocessor bit (multiprocessor format).

In multiprocessor communication, each receiving processor is addressed by an ID. A serial communication cycle consists of an ID-sending cycle that identifies the receiving processor, and a data-sending cycle. The multiprocessor bit distinguishes ID-sending cycles from data-sending cycles.

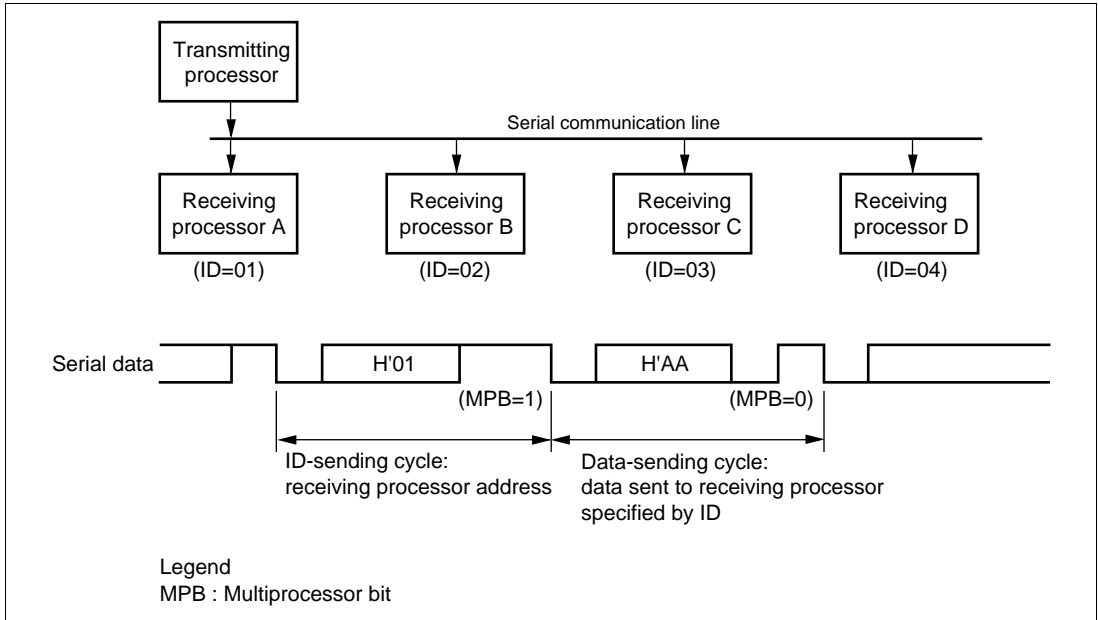
The transmitting processor starts by sending the ID of the receiving processor with which it wants to communicate as data with the multiprocessor bit set to 1. Next the transmitting processor sends transmit data with the multiprocessor bit cleared to 0.

Receiving processors skip incoming data until they receive data with the multiprocessor bit set to 1. When they receive data with the multiprocessor bit set to 1, receiving processors compare the data with their IDs. Processors with IDs not matching the received data skip further incoming data until they again receive data with the multiprocessor bit set to 1. Multiple processors can send and receive data in this way.

Figure 13.9 shows an example of communication among different processors using a multiprocessor format.

**Communication Formats:** Four formats are available. Parity bit settings are ignored when a multiprocessor format is selected. For details see table 13.10.

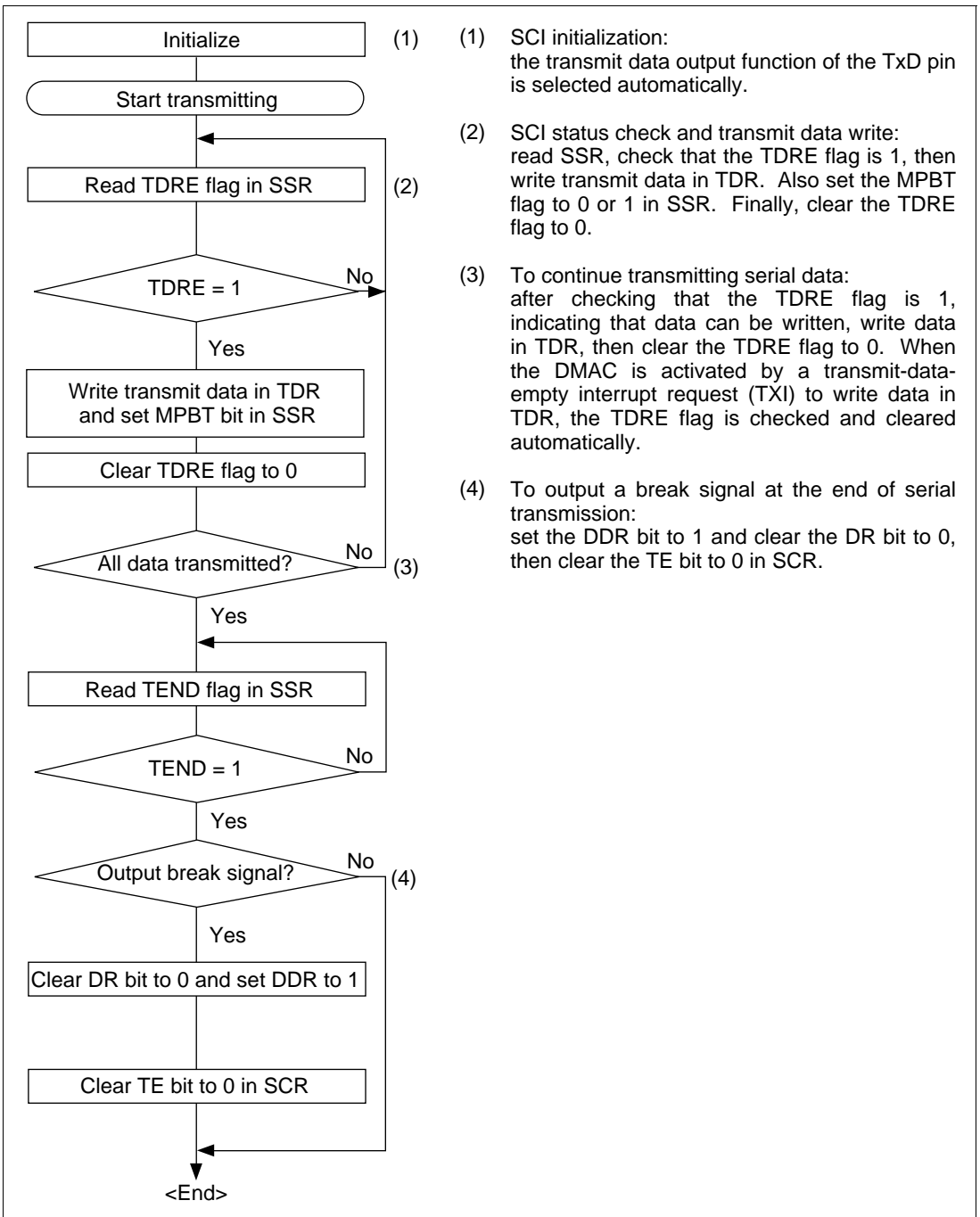
**Clock:** See the description of asynchronous mode.



**Figure 13.9 Example of Communication among Processors using Multiprocessor Format (Sending Data H'AA to Receiving Processor A)**

### Transmitting and Receiving Data:

- Transmitting Multiprocessor Serial Data: Figure 13.10 shows a sample flowchart for transmitting multiprocessor serial data and indicates the procedure to follow.



**Figure 13.10 Sample Flowchart for Transmitting Multiprocessor Serial Data**

In transmitting serial data, the SCI operates as follows:

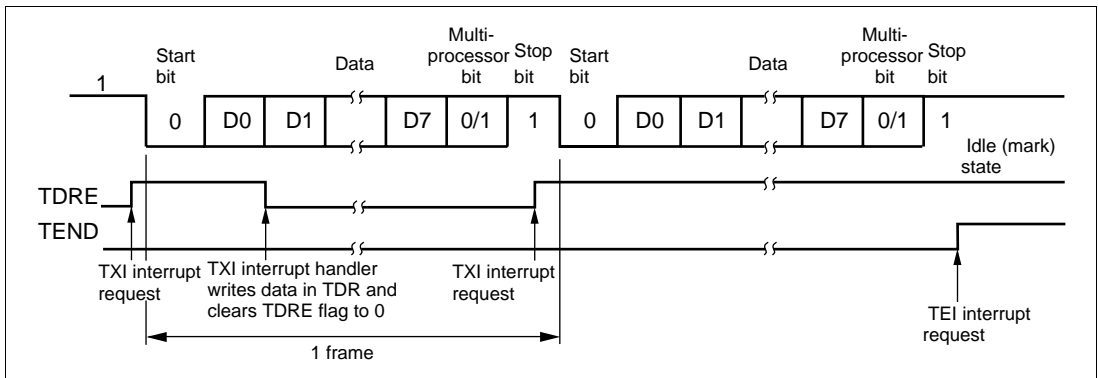
- The SCI monitors the TDRE flag in SSR. When the TDRE flag is cleared to 0, the SCI recognizes that TDR contains new data, and loads this data from TDR into TSR.
- After loading the data from TDR to TSR, the SCI sets the TDRE flag to 1 and starts transmitting. If the TIE bit is set to 1 in SCR, the SCI requests a transmit-data-empty interrupt (TXI) at this time.

Serial transmit data is transmitted in the following order from the TxD pin:

- Start bit: One 0 bit is output.
- Transmit data: 7 or 8 bits are output, LSB first.
- Multiprocessor bit: One multiprocessor bit (MPBT value) is output.
- Stop bit(s): One or two 1 bits (stop bits) are output.
- Mark state: Output of 1 bits continues until the start bit of the next transmit data.

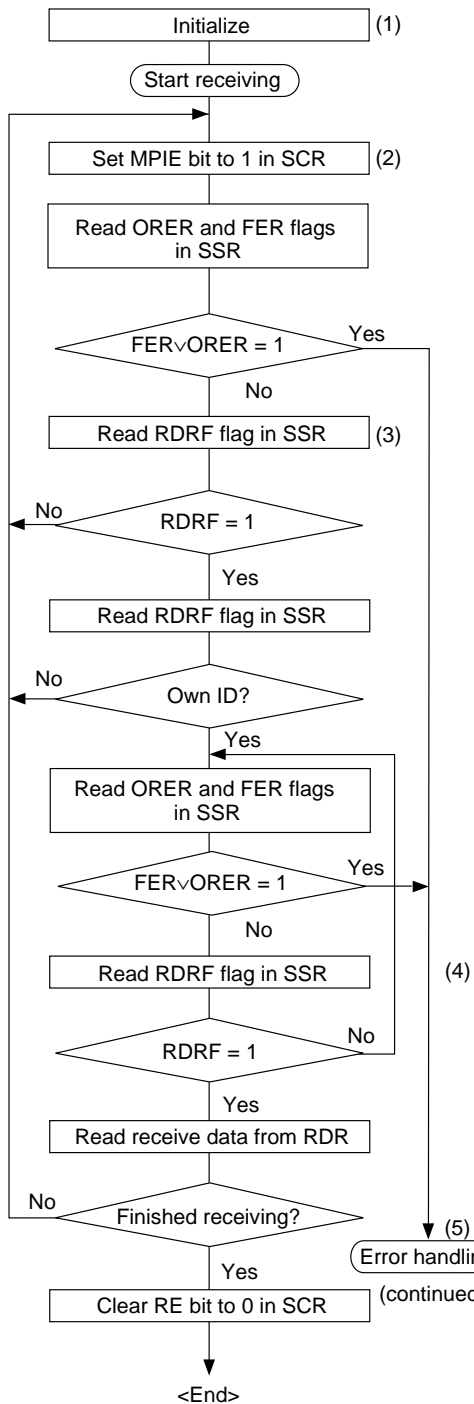
- The SCI checks the TDRE flag when it outputs the stop bit. If the TDRE flag is 0, the SCI loads new data from TDR into TSR, outputs the stop bit, then begins serial transmission of the next frame. If the TDRE flag is 1, the SCI sets the TEND flag to 1 in SSR, outputs the stop bit, then continues output of 1 bits in the mark state. If the TEIE bit is set to 1 in SCR, a transmit-end interrupt (TEI) is requested at this time

Figure 13.11 shows an example of SCI transmit operation using a multiprocessor format.



**Figure 13.11 Example of SCI Transmit Operation  
(8-Bit Data with Multiprocessor Bit and One Stop Bit)**

- Receiving Multiprocessor Serial Data: Figure 13.12 shows a sample flowchart for receiving multiprocessor serial data and indicates the procedure to follow.



- (1) SCI initialization:  
the receive data input function of the RxD pin is selected automatically.
- (2) ID receive cycle:  
set the MPIOE bit to 1 in SCR.
- (3) SCI status check and ID check:  
read SSR, check that the RDRF flag is set to 1, then read data from RDR and compare it with the processor's own ID. If the ID does not match, set the MPIOE bit to 1 again and clear the RDRF flag to 0. If the ID matches, clear the RDRF flag to 0.
- (4) SCI status check and data receiving:  
read SSR, check that the RDRF flag is set to 1, then read data from RDR.
- (5) Receive error handling and break detection:  
if a receive error occurs, read the ORER and FER flags in SSR to identify the error. After executing the necessary error handling, clear the ORER and FER flags both to 0. Receiving cannot resume while either the ORER or FER flag remains set to 1. When a framing error occurs, the RxD pin can be read to detect the break state.

(4)

(5)

(continued on next page)

**Figure 13.12 Sample Flowchart for Receiving Multiprocessor Serial Data (1)**

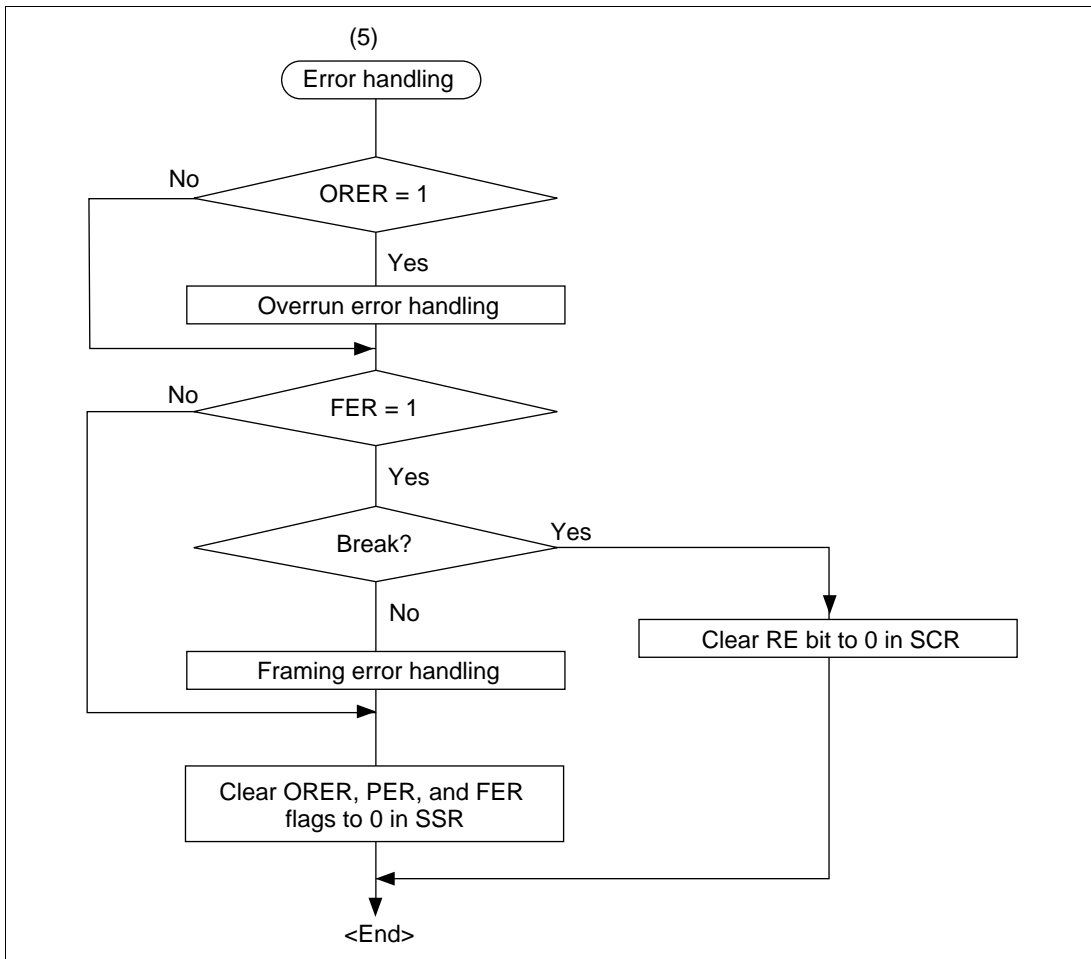
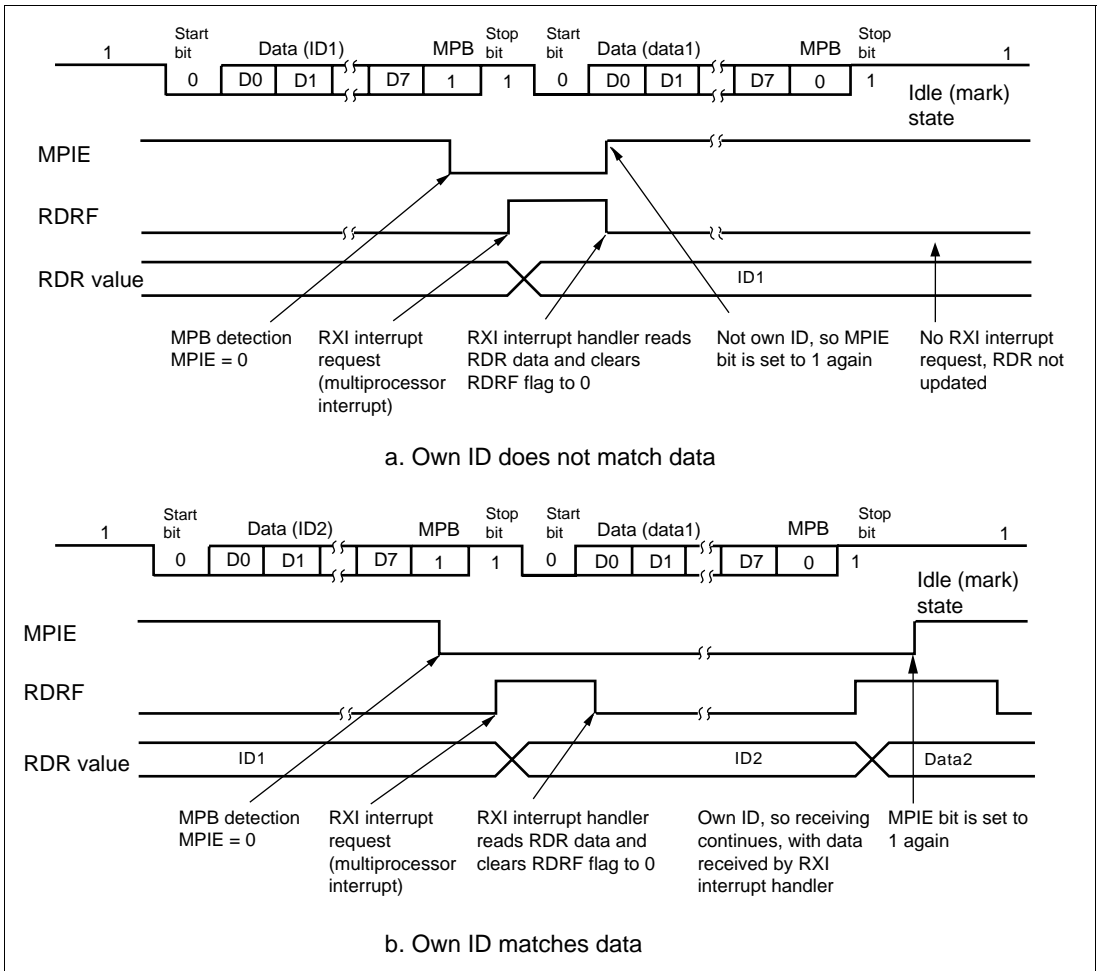


Figure 13.12 Sample Flowchart for Receiving Multiprocessor Serial Data (2)



Figure 13.13 shows an example of SCI receive operation using a multiprocessor format.



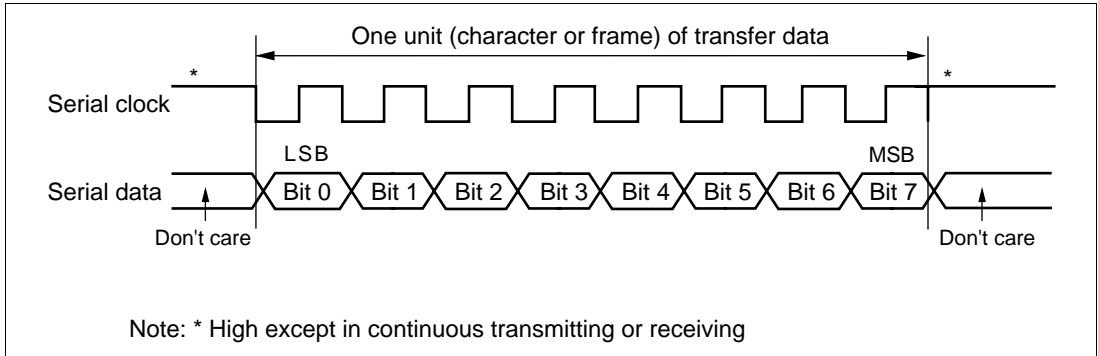
**Figure 13.13 Example of SCI Receive Operation (8-Bit Data with Multiprocessor Bit and One Stop Bit)**

### 13.3.4 Synchronous Operation

In synchronous mode, the SCI transmits and receives data in synchronization with clock pulses. This mode is suitable for high-speed serial communication.

The SCI transmitter and receiver share the same clock but are otherwise independent, so full-duplex communication is possible. The transmitter and the receiver are also double-buffered, so continuous transmitting or receiving is possible by reading or writing data while transmitting or receiving is in progress.

Figure 13.14 shows the general format in synchronous serial communication.



**Figure 13.14 Data Format in Synchronous Communication**

In synchronous serial communication, each data bit is placed on the communication line from one falling edge of the serial clock to the next. Data is guaranteed valid at the rise of the serial clock. In each character, the serial data bits are transferred in order from LSB (first) to MSB (last). After output of the MSB, the communication line remains in the state of the MSB. In synchronous mode the SCI receives data by synchronizing with the rise of the serial clock.

**Communication Format:** The data length is fixed at 8 bits. No parity bit or multiprocessor bit can be added.

**Clock:** An internal clock generated by the on-chip baud rate generator or an external clock input from the SCK pin can be selected by means of the  $C/\bar{A}$  bit in SMR and the CKE1 and CKE0 bits in SCR. See table 13.6 for details of SCI clock source selection.

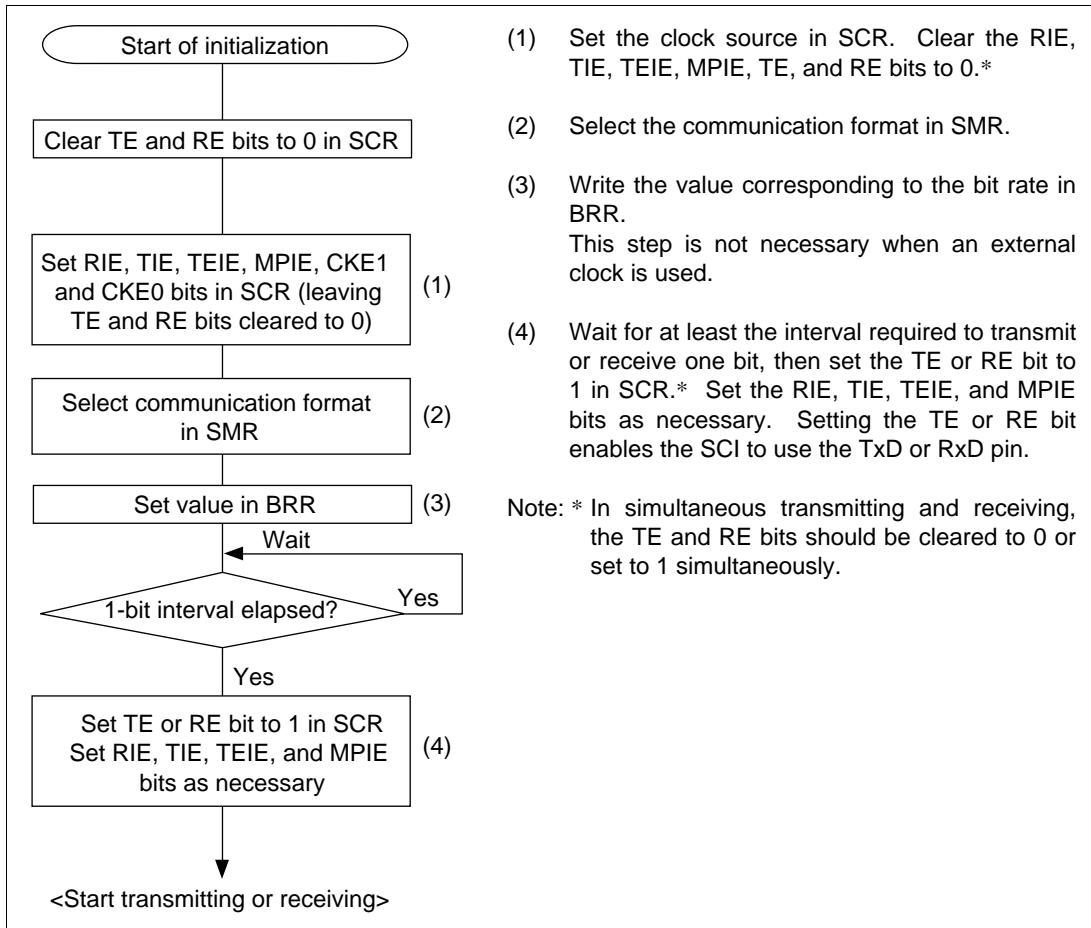
When the SCI operates on an internal clock, it outputs the clock source at the SCK pin. Eight clock pulses are output per transmitted or received character. When the SCI is not transmitting or receiving, the clock signal remains in the high state. If receiving in single-character units is required, an external clock should be selected.

#### **Transmitting and Receiving Data:**

- **SCI Initialization (Synchronous Mode):** Before transmitting or receiving data, clear the TE and RE bits to 0 in SCR, then initialize the SCI as follows.

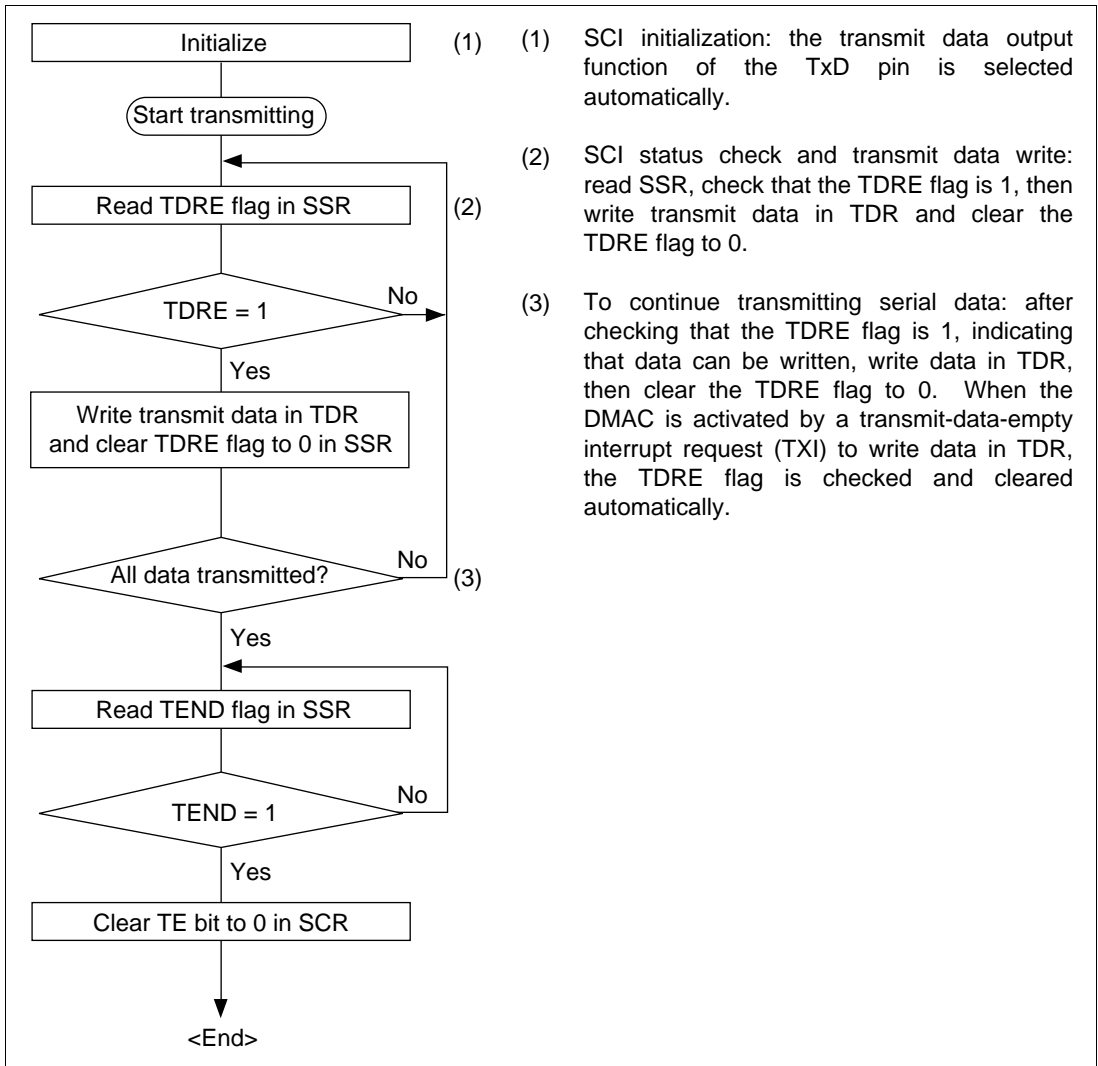
When changing the communication mode or format, always clear the TE and RE bits to 0 before following the procedure given below. Clearing TE to 0 sets the TDRE flag to 1 and initializes TSR. Note that clearing RE to 0, however, does not initialize the RDRF, PER, and ORE flags, or RDR, which retain their previous contents.

Figure 13.15 shows a sample flowchart for initializing the SCI.



**Figure 13.15 Sample Flowchart for SCI Initialization**

- **Transmitting Serial Data (Synchronous Mode):** Figure 13.16 shows a sample flowchart for transmitting serial data and indicates the procedure to follow.



**Figure 13.16 Sample Flowchart for Serial Transmitting**

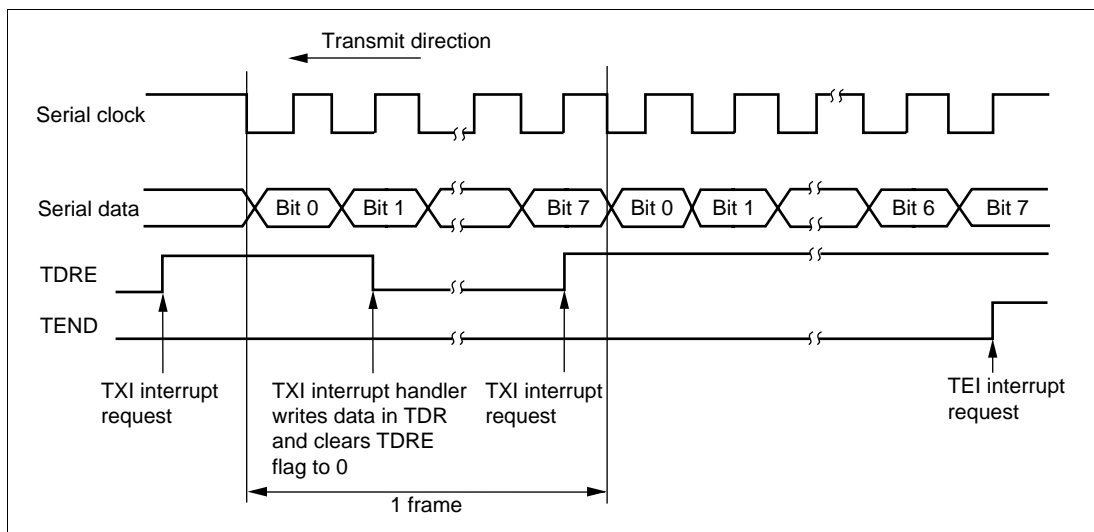
In transmitting serial data, the SCI operates as follows.

- The SCI monitors the TDRE flag in SSR. When the TDRE flag is cleared to 0, the SCI recognizes that TDR contains new data, and loads this data from TDR into TSR.
- After loading the data from TDR to TSR, the SCI sets the TDRE flag to 1 and starts transmitting. If the TIE bit is set to 1 in SCR, the SCI requests a transmit-data-empty interrupt (TXI) at this time.

If clock output is selected, the SCI outputs eight serial clock pulses. If an external clock source is selected, the SCI outputs data in synchronization with the input clock. Data is output from the TxD pin in order from LSB (bit 0) to MSB (bit 7).

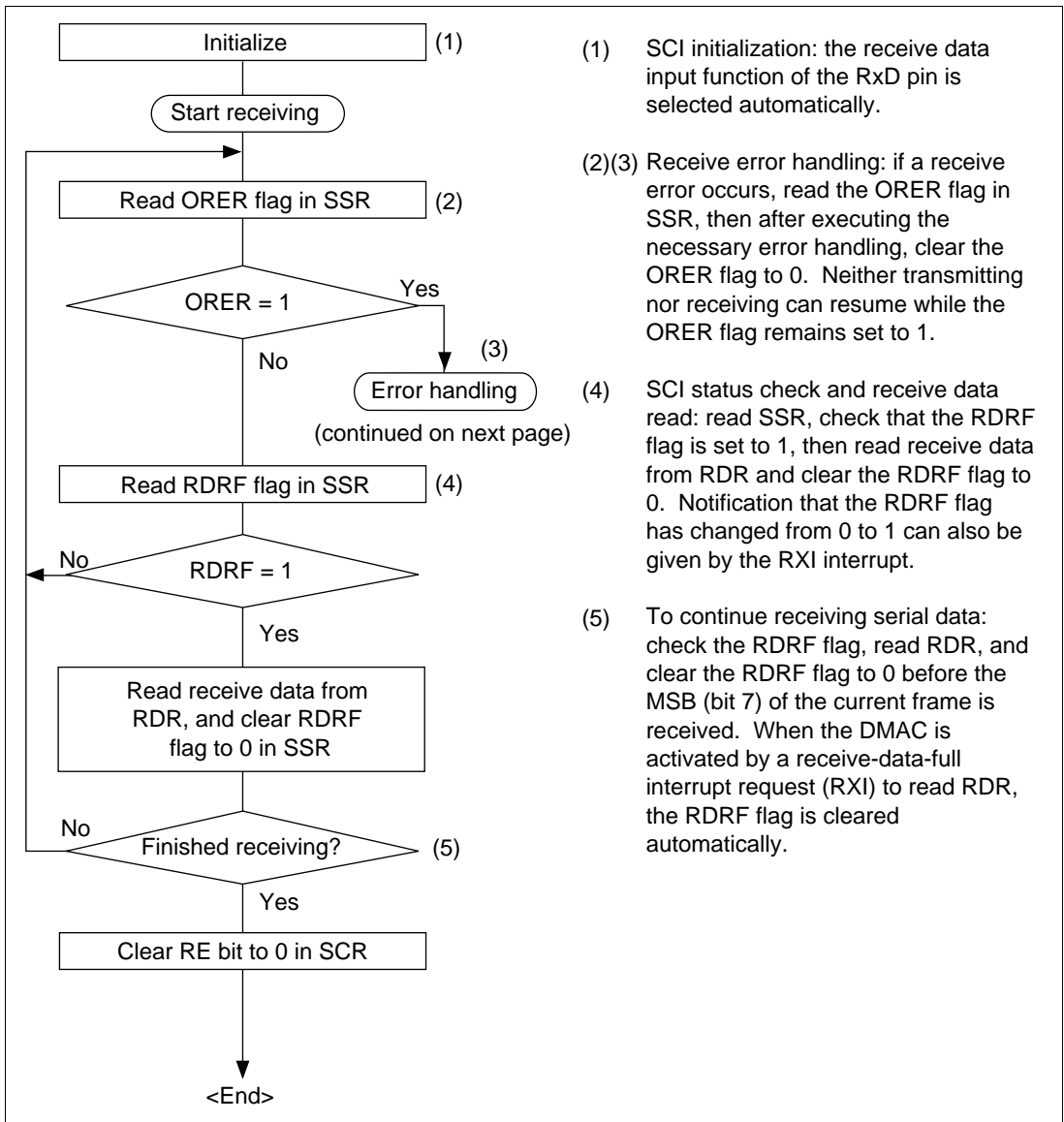
- The SCI checks the TDRE flag when it outputs the MSB (bit 7). If the TDRE flag is 0, the SCI loads data from TDR into TSR and begins serial transmission of the next frame. If the TDRE flag is 1, the SCI sets the TEND flag to 1 in SSR, and after transmitting the MSB (bit 7), holds the TxD pin in the MSB state. If the TEIE bit is set to 1 in SCR, a transmit-end interrupt (TEI) is requested at this time
- After the end of serial transmission, the SCK pin is held in a constant state.

Figure 13.17 shows an example of SCI transmit operation.

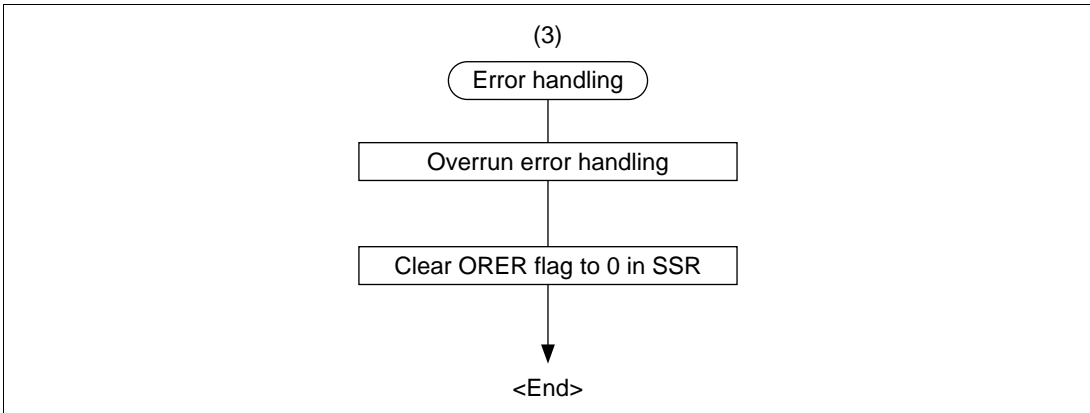


**Figure 13.17 Example of SCI Transmit Operation**

- **Receiving Serial Data (Synchronous Mode):** Figure 13.18 shows a sample flowchart for receiving serial data and indicates the procedure to follow. When switching from asynchronous to synchronous mode, make sure that the ORER, PER, and FER flags are cleared to 0. If the FER or PER flag is set to 1 the RDRF flag will not be set and both transmitting and receiving will be disabled.



**Figure 13.18 Sample Flowchart for Serial Receiving (1)**



**Figure 13.18 Sample Flowchart for Serial Receiving (2)**

In receiving, the SCI operates as follows:

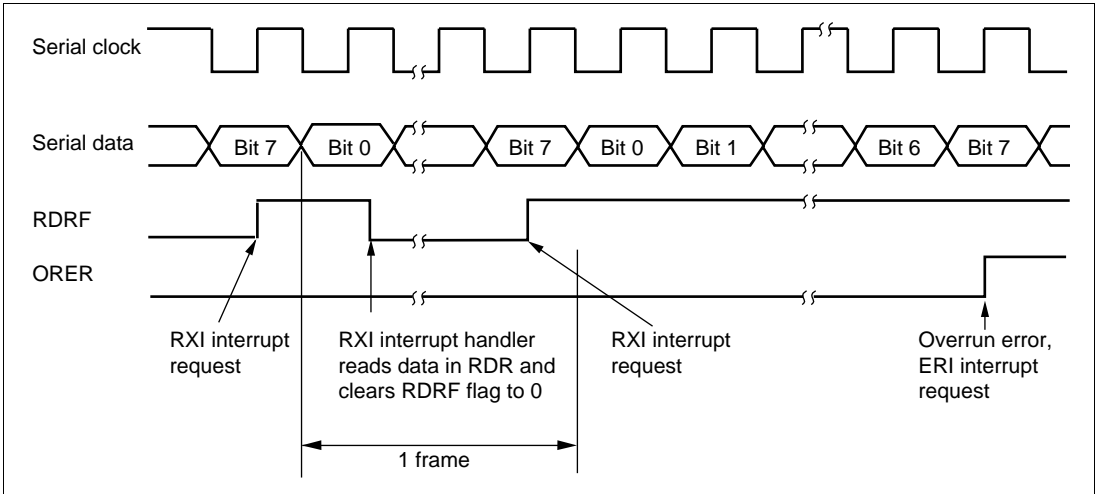
- The SCI synchronizes with serial clock input or output and synchronizes internally.
- Receive data is stored in RSR in order from LSB to MSB.

After receiving the data, the SCI checks that the RDRF flag is 0, so that receive data can be transferred from RSR to RDR. If this check passes, the RDRF flag is set to 1 and the received data is stored in RDR. If the checks fails (receive error), the SCI operates as shown in table 13.11.

When a receive error has been identified in the error check, subsequent transmit and receive operations are disabled.

- When the RDRF flag is set to 1, if the RIE bit is set to 1 in SCR, a receive-data-full interrupt (RXI) is requested. If the ORER flag is set to 1 and the RIE bit in SCR is also set to 1, a receive-error interrupt (ERI) is requested.

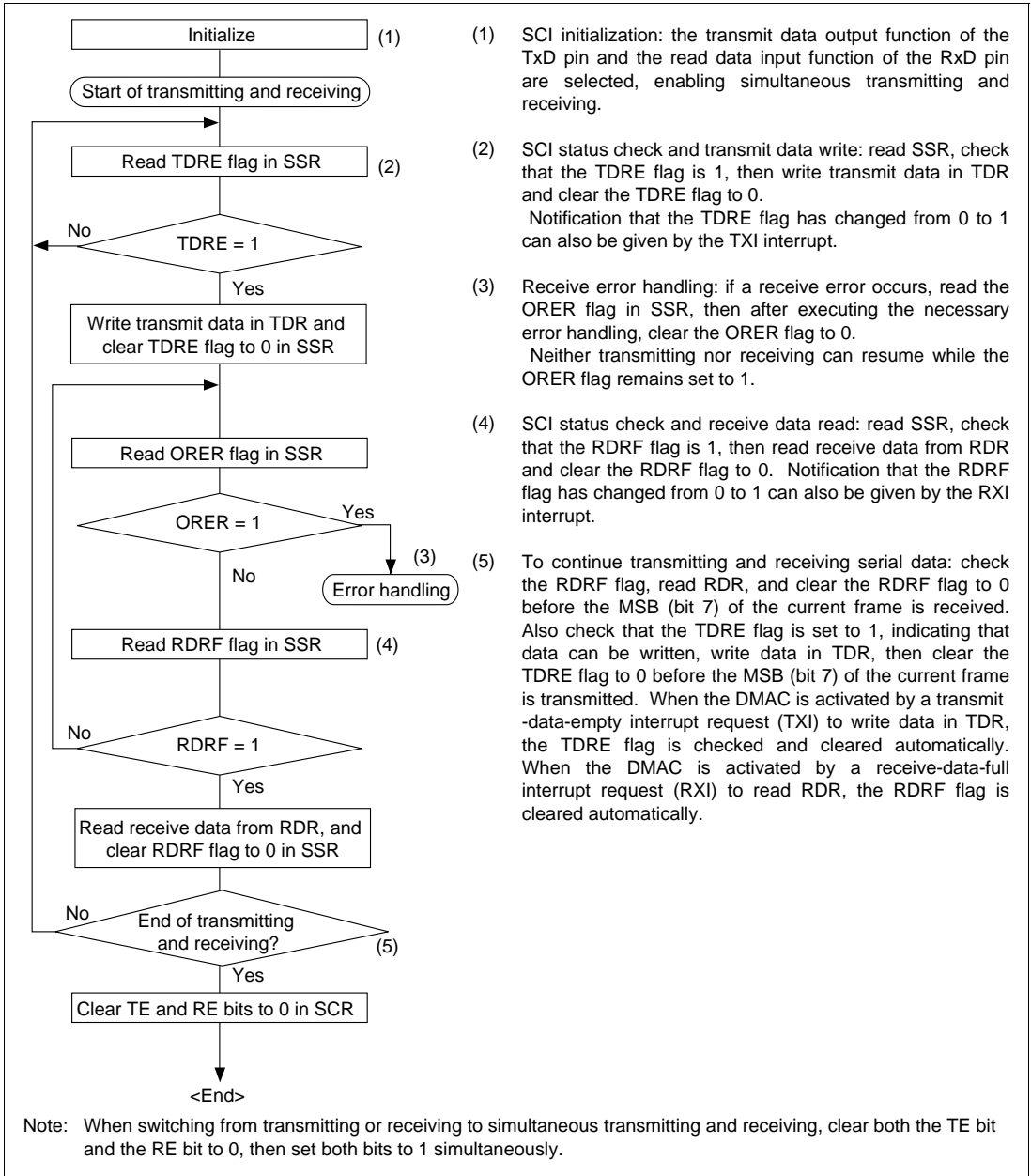
Figure 13.19 shows an example of SCI receive operation.



**Figure 13.19 Example of SCI Receive Operation**



- **Transmitting and Receiving Data Simultaneously (Synchronous Mode):** Figure 13.20 shows a sample flowchart for transmitting and receiving serial data simultaneously and indicates the procedure to follow.



**Figure 13.20 Sample Flowchart for Simultaneous Serial Transmitting and Receiving**

## 13.4 SCI Interrupts

The SCI has four interrupt request sources: the transmit-end interrupt (TEI), receive-error interrupt (ERI), receive-data-full interrupt (RXI), and transmit-data-empty interrupt (TXI). Table 13.12 lists the interrupt sources and indicates their priority. These interrupts can be enabled or disabled by the TIE, RIE, and TEIE bits in SCR. Each interrupt request is sent separately to the interrupt controller.

A TXI interrupt is requested when the TDRE flag is set to 1 in SSR. A TEI interrupt is requested when the TEND flag is set to 1 in SSR. A TXI interrupt request can activate the DMAC to transfer data. Data transfer by the DMAC automatically clears the TDRE flag to 0. A TEI interrupt request cannot activate the DMAC.

An RXI interrupt is requested when the RDRF flag is set to 1 in SSR. An ERI interrupt is requested when the ORER, PER, or FER flag is set to 1 in SSR. An RXI interrupt can activate the DMAC to transfer data. Data transfer by the DMAC automatically clears the RDRF flag to 0. An ERI interrupt request cannot activate the DMAC.

The DMAC can be activated by interrupts from SCI channel 0.

**Table 13.12 SCI Interrupt Sources**

Interrupt Source	Description	Priority	
ERI	Receive error (ORER, FER, or PER)	High	
RXI	Receive data register full (RDRF)	↑	
TXI	Transmit data register empty (TDRE)		
TEI	Transmit end (TEND)		Low

## 13.5 Usage Notes

### 13.5.1 Notes on Use of SCI

Note the following points when using the SCI.

**TDR Write and TDRE Flag:** The TDRE flag in SSR is a status flag indicating the loading of transmit data from TDR to TSR. The SCI sets the TDRE flag to 1 when it transfers data from TDR to TSR.

Data can be written into TDR regardless of the state of the TDRE flag. If new data is written in TDR when the TDRE flag is 0, the old data stored in TDR will be lost because this data has not yet been transferred to TSR. Before writing transmit data in TDR, be sure to check that the TDRE flag is set to 1.

**Simultaneous Multiple Receive Errors:** Table 13.13 shows the state of the SSR status flags when multiple receive errors occur simultaneously. When an overrun error occurs the RSR contents are not transferred to RDR, so receive data is lost.

**Table 13.13 SSR Status Flags and Transfer of Receive Data**

SSR Status Flags				Receive Data Transfer	
RDRF	ORER	FER	PER	RSR → RDR	Receive Errors
1	1	0	0	×	Overrun error
0	0	1	0	○	Framing error
0	0	0	1	○	Parity error
1	1	1	0	×	Overrun error + framing error
1	1	0	1	×	Overrun error + parity error
0	0	1	1	○	Framing error + parity error
1	1	1	1	×	Overrun error + framing error + parity error

Notes: ○ : Receive data is transferred from RSR to RDR.

× : Receive data is not transferred from RSR to RDR.

**Break Detection and Processing:** Break signals can be detected by reading the RxD pin directly when a framing error (FER) is detected. In the break state the input from the RxD pin consists of all 0s, so the FER flag is set and the parity error flag (PER) may also be set. In the break state the SCI receiver continues to operate, so if the FER flag is cleared to 0 it will be set to 1 again.

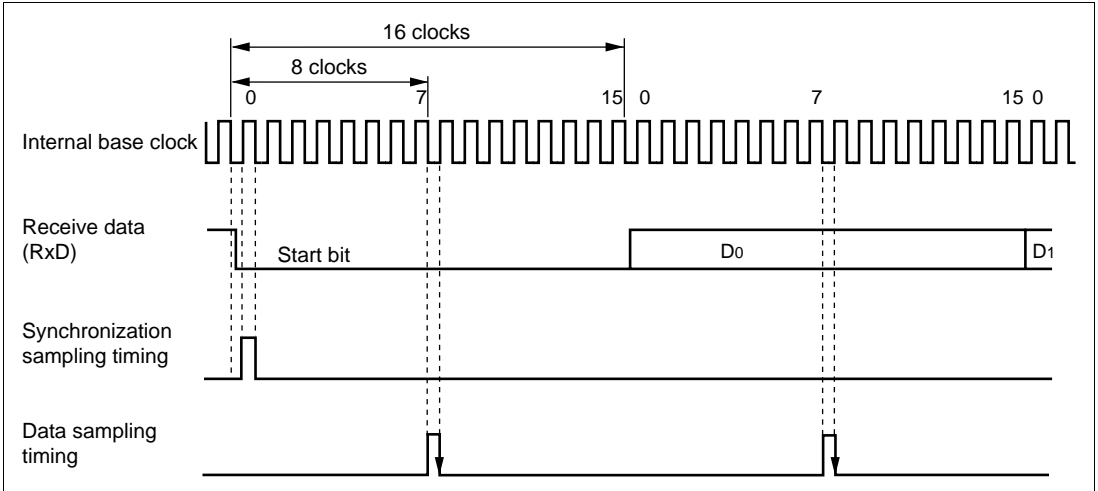
**Sending a Break Signal:** The input/output condition and level of the TxD pin are determined by DR and DDR bits. This feature can be used to send a break signal.

After the serial transmitter is initialized, the DR value substitutes for the mark state until the TE bit is set to 1 (the TxD pin function is not selected until the TE bit is set to 1). The DDR and DR bits should therefore be set to 1 beforehand.

To send a break signal during serial transmission, clear the DR bit to 0, then clear the TE bit to 0. When the TE bit is cleared to 0 the transmitter is initialized, regardless of its current state, so the TxD pin becomes an input/output outputting the value 0.

**Receive Error Flags and Transmitter Operation (Synchronous Mode Only):** When a receive error flag (ORER, PER, or FER) is set to 1 the SCI will not start transmitting, even if the TDRE flag is cleared to 0. Be sure to clear the receive error flags to 0 when starting to transmit. Note that clearing the RE bit to 0 does not clear the receive error flags to 0.

**Receive Data Sampling Timing in Asynchronous Mode and Receive Margin:** In asynchronous mode the SCI operates on a base clock with 16 times the bit rate frequency. In receiving, the SCI synchronizes internally with the fall of the start bit, which it samples on the base clock. Receive data is latched at the rising edge of the eighth base clock pulse. See figure 13.21.



**Figure 13.21 Receive Data Sampling Timing in Asynchronous Mode**

The receive margin in asynchronous mode can therefore be expressed as shown in equation (1).

$$M = \left| \left( 0.5 - \frac{1}{2N} \right) - (L - 0.5) F - \frac{|D - 0.5|}{N} (1 + F) \right| \times 100\% \quad \dots \dots \dots (1)$$

- M: Receive margin (%)
- N: Ratio of clock frequency to bit rate (N = 16)
- D: Clock duty cycle (L = 0 to 1.0)
- L: Frame length (L = 9 to 12)
- F: Absolute deviation of clock frequency

From equation (1), if  $F = 0$  and  $D = 0.5$ , the receive margin is 46.875%, as given by equation (2).

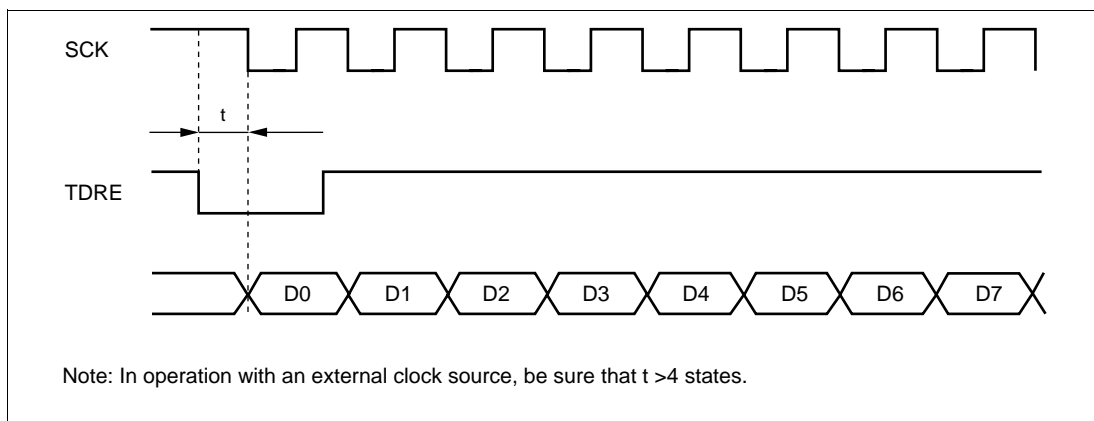
$$D = 0.5, F = 0$$

$$M = \left( 0.5 - \frac{1}{2 \times 16} \right) \times 100\% \\ = 46.875\% \quad \dots\dots\dots (2)$$

This is a theoretical value. A reasonable margin to allow in system designs is 20% to 30%.

### Restrictions on Use of DMAC:

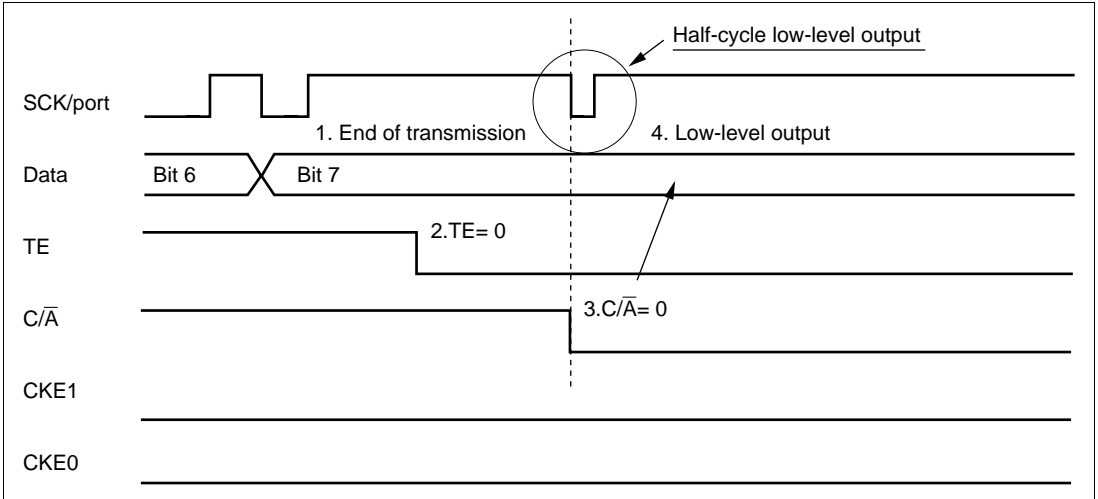
- When an external clock source is used for the serial clock, after the DMAC updates TDR, allow an inversion of at least five system clock ( $\phi$ ) cycles before input of the serial clock to start transmitting. If the serial clock is input within four states of the TDR update, a malfunction may occur. (See figure 13.22)
- To have the DMAC read RDR, be sure to select the corresponding SCI receive-data-full interrupt (RXI) as the activation source with bits DTS2 to DTS0 in DTCR.



**Figure 13.22 Example of Synchronous Transmission Using DMAC**

## Switching from SCK Pin Function to Port Pin Function:

- Problem in Operation: When switching the SCK pin function to the output port function (high-level output) by making the following settings while  $\text{DDR} = 1$ ,  $\text{DR} = 1$ ,  $\text{C}/\overline{\text{A}} = 1$ ,  $\text{CKE1} = 0$ ,  $\text{CKE0} = 0$ , and  $\text{TE} = 1$  (synchronous mode), low-level output occurs for one half-cycle.
1. End of serial data transmission
  2.  $\text{TE} = 0$
  3.  $\text{C}/\overline{\text{A}} = 0$  ... switchover to port output
  4. Occurrence of low-level output (see figure 13.23)

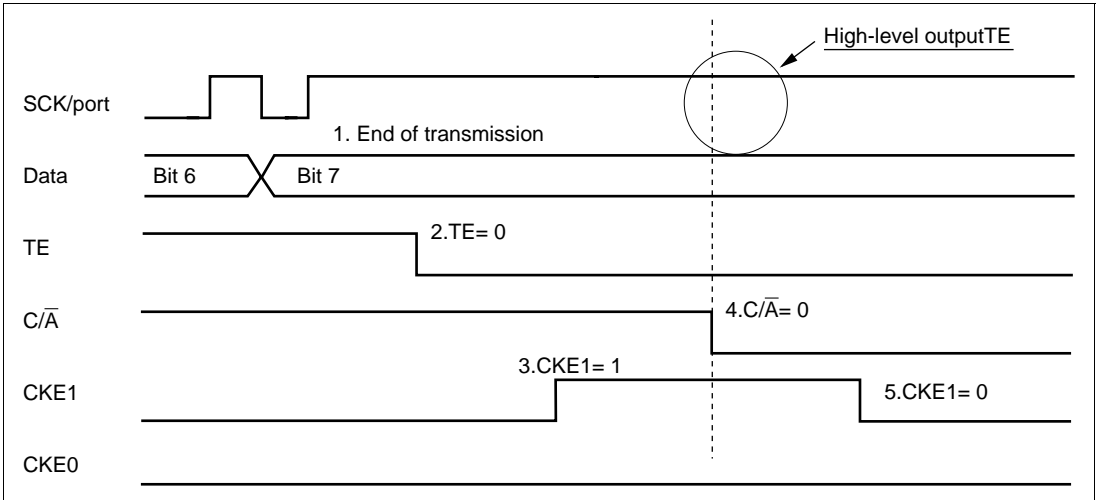


**Figure 13.23 Operation when Switching from SCK Pin Function to Port Pin Function**

- **Sample Procedure for Avoiding Low-Level Output:** As this sample procedure temporarily places the SCK pin in the input state, the SCK/port pin should be pulled up beforehand with an external circuit.

With  $DDR = 1$ ,  $DR = 1$ ,  $C/\bar{A} = 1$ ,  $CKE1 = 0$ ,  $CKE0 = 0$ , and  $TE = 1$ , make the following settings in the order shown.

1. End of serial data transmission
2. TE bit = 0
3. CKE1 bit = 1
4.  $C/\bar{A}$  bit = 0 ... switchover to port output
5. CKE1 bit = 0



**Figure 13.24 Operation when Switching from SCK Pin Function to Port Pin Function (Example of Preventing Low-Level Output)**





# Section 14 Smart Card Interface

## 14.1 Overview

An IC card (smart card) interface conforming to the ISO/IEC 7816-3 (Identification Card) standard is supported as an extension of the serial communication interface (SCI) functions.

Switchover between the normal serial communication interface and the smart card interface is controlled by a register setting.

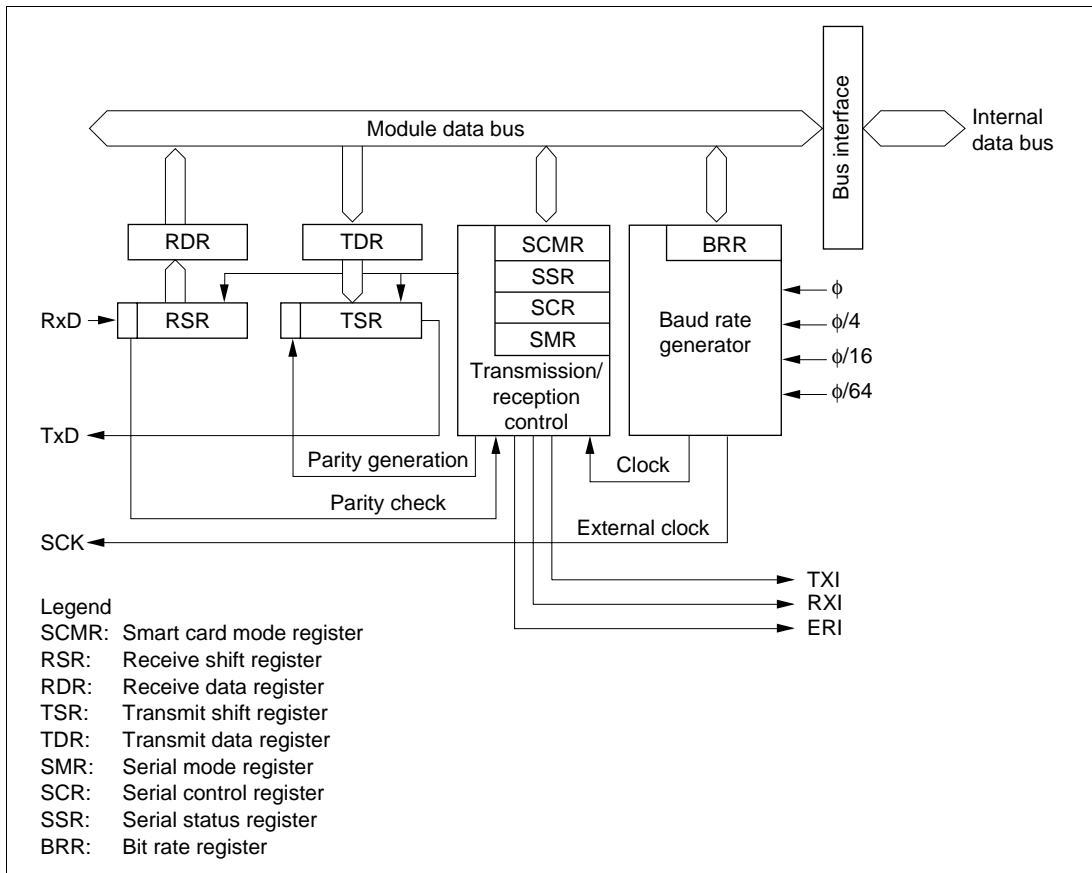
### 14.1.1 Features

Features of the smart card interface supported by the H8/3067 Series are listed below.

- Asynchronous communication
  - Data length: 8 bits
  - Parity bit generation and checking
  - Transmission of error signal (parity error) in receive mode
  - Error signal detection and automatic data retransmission in transmit mode
  - Direct convention and inverse convention both supported
- Built-in baud rate generator allows any bit rate to be selected
- Three interrupt sources
  - There are three interrupt sources—transmit-data-empty, receive-data-full, and transmit/receive error—that can issue requests independently.
  - The transmit-data-empty interrupt and receive-data-full interrupt can activate the DMA controller (DMAC) to execute data transfer.

## 14.1.2 Block Diagram

Figure 14.1 shows a block diagram of the smart card interface.



**Figure 14.1 Block Diagram of Smart Card Interface**

## 14.1.3 Pin Configuration

Table 14.1 shows the smart card interface pins.

**Table 14.1 Smart Card Interface Pins**

Pin Name	Abbreviation	I/O	Function
Serial clock pin	SCK	I/O	Clock input/output
Receive data pin	RxD	Input	Receive data input
Transmit data pin	TxD	Output	Transmit data output

## 14.1.4 Register Configuration

The smart card interface has the internal registers listed in table 14.2. The BRR, TDR, and RDR registers have their normal serial communication interface functions, as described in section 13, Serial Communication Interface.

**Table 14.2 Smart Card Interface Registers**

Channel	Address* <sup>1</sup>	Name	Abbreviation	R/W	Initial Value
0	H'FFFB0	Serial mode register	SMR	R/W	H'00
	H'FFFB1	Bit rate register	BRR	R/W	H'FF
	H'FFFB2	Serial control register	SCR	R/W	H'00
	H'FFFB3	Transmit data register	TDR	R/W	H'FF
	H'FFFB4	Serial status register	SSR	R/(W)* <sup>2</sup>	H'84
	H'FFFB5	Receive data register	RDR	R	H'00
	H'FFFB6	Smart card mode register	SCMR	R/W	H'F2
1	H'FFFB8	Serial mode register	SMR	R/W	H'00
	H'FFFB9	Bit rate register	BRR	R/W	H'FF
	H'FFBFA	Serial control register	SCR	R/W	H'00
	H'FFFB B	Transmit data register	TDR	R/W	H'FF
	H'FFBFC	Serial status register	SSR	R/(W)* <sup>2</sup>	H'84
	H'FFBFD	Receive data register	RDR	R	H'00
	H'FFBFE	Smart card mode register	SCMR	R/W	H'F2
2	H'FFFC0	Serial mode register	SMR	R/W	H'00
	H'FFFC1	Bit rate register	BRR	R/W	H'FF
	H'FFFC2	Serial control register	SCR	R/W	H'00
	H'FFFC3	Transmit data register	TDR	R/W	H'FF
	H'FFFC4	Serial status register	SSR	R/(W)* <sup>2</sup>	H'84
	H'FFFC5	Receive data register	RDR	R	H'00
	H'FFFC6	Smart card mode register	SCMR	R/W	H'F2

- Notes: 1. Lower 20 bits of the address in advanced mode.  
 2. Only 0 can be written in bits 7 to 3, to clear the flags.

## 14.2 Register Descriptions

This section describes the new or modified registers and bit functions in the smart card interface.

### 14.2.1 Smart Card Mode Register (SCMR)

SCMR is an 8-bit readable/writable register that selects smart card interface functions.

Bit	7	6	5	4	3	2	1	0
	—	—	—	—	SDIR	SINV	—	SMIF
Initial value	1	1	1	1	0	0	1	0
Read/Write	—	—	—	—	R/W	R/W	—	R/W

**Reserved bits**
**Reserved bit**

**Smart card interface mode select**  
Enables or disables the smart card interface function

**Smart card data invert**  
Inverts data logic levels

**Smart card data transfer direction**  
Selects the serial/parallel conversion format

SCMR is initialized to H'F2 by a reset and in standby mode.

**Bits 7 to 4—Reserved:** Read-only bits, always read as 1.

**Bit 3—Smart Card Data Transfer Direction (SDIR):** Selects the serial/parallel conversion format.\*<sup>1</sup>

Bit 3 SDIR	Description
0	TDR contents are transmitted LSB-first Receive data is stored LSB-first in RDR (Initial value)
1	TDR contents are transmitted MSB-first Receive data is stored MSB-first in RDR

**Bit 2—Smart Card Data Invert (SINV):** Specifies inversion of the data logic level. This function is used in combination with the SDIR bit to communicate with inverse-convention cards.\*<sup>2</sup> The SINV bit does not affect the logic level of the parity bit. For parity settings, see section 14.3.4, Register Settings.

Bit 2 SINV	Description	
0	Unmodified TDR contents are transmitted Receive data is stored unmodified in RDR	(Initial value)
1	Inverted TDR contents are transmitted Receive data is inverted before storage in RDR	

**Bit 1—Reserved:** Read-only bit, always read as 1.

**Bit 0—Smart Card Interface Mode Select (SMIF):** Enables the smart card interface function.

Bit 0 SMIF	Description	
0	Smart card interface function is disabled	(Initial value)
1	Smart card interface function is enabled	

- Notes:
1. The function for switching between LSB-first and MSB-first mode can also be used with the normal serial communication interface. Note that when the communication format data length is set to 7 bits and MSB-first mode is selected for the serial data to be transferred, bit 0 of TDR is not transmitted, and only bits 7 to 1 of the received data are valid.
  2. The data logic level inversion function can also be used with the normal serial communication interface. Note that, when inverting the serial data to be transferred, parity transmission and parity checking is based on the number of high-level periods at the serial data I/O pin, and not on the register value.

#### 14.2.2 Serial Status Register (SSR)

The function of SSR bit 4 is modified in smart card interface mode. This change also causes a modification to the setting conditions for bit 2 (TEND).

Bit	7	6	5	4	3	2	1	0
	TDRE	RDRF	ORER	ERS	PER	TEND	MPB	MPBT
Initial value	1	0	0	0	0	1	0	0
Read/Write	R/(W)*	R/(W)*	R/(W)*	R/(W)*	R/(W)*	R	R	R/W

**Transmit end**  
Status flag indicating end of transmission

**Error signal status (ERS)**  
Status flag indicating that an error signal has been received

Note: \* Only 0 can be written, to clear the flag.

**Bits 7 to 5:** These bits operate as in normal serial communication. For details see section 13.2.7, Serial Status Register (SSR).

**Bit 4—Error Signal Status (ERS):** In smart card interface mode, this flag indicates the status of the error signal sent from the receiving device to the transmitting device. The smart card interface does not detection framing errors.

#### Bit 4

ERS	Description
0	Indicates normal transmission, with no error signal returned (Initial value) [Clearing conditions] The chip is reset, or enters standby mode or module stop mode Software reads ERS while it is set to 1, then writes 0.
1	Indicates that the receiving device sent an error signal reporting a parity error [Setting condition] A low error signal was sampled.

Note: Clearing the TE bit to 0 in SCR does not affect the ERS flag, which retains its previous value.

**Bits 3 to 0:** These bits operate as in normal serial communication. For details see section 13.2.7, Serial Status Register (SSR). The setting conditions for transmit end (TEND), however, are modified as follows.

Bit 2 TEND	Description
0	<p>Transmission is in progress</p> <p>[Clearing conditions]</p> <p>Software reads TDRE while it is set to 1, then writes 0 in the TDRE flag.</p> <p>The DMAC or DTC writes data in TDR.</p>
1	<p>End of transmission</p> <p>[Setting conditions] (Initial value)</p> <p>The chip is reset or enters standby mode.</p> <p>The TE bit and FER/ERS bit are both cleared to 0 in SCR.</p> <p>TDRE is 1 and FER/ERS is 0 at a time 2.5 etu after the last bit of a 1-byte serial character is transmitted (normal transmission).</p>

Note: An etu (elementary time unit) is the time needed to transmit one bit.

### 14.2.3 Serial Mode Register (SMR)

The function of SMR bit 7 is modified in smart card interface mode. This change also causes a modification to the function of bits 1 and 0 in the serial control register (SCR).

Bit	7	6	5	4	3	2	1	0
	GM	CHR	PE	O/ $\bar{E}$	STOP	MP	CKS1	CKS0
Initial value	0	0	0	0	0	0	0	0
Read/Write	R/W	R/W	R/W	R/W	R/W	R/W	R/W	R/W

**Bit 7—GSM Mode (GM):** With the normal smart card interface, this bit is cleared to 0. Setting this bit to 1 selects GSM mode, an additional mode for controlling the timing for setting the TEND flag that indicates completion of transmission, and the type of clock output used. The details of the additional clock output control mode are specified by the CKE1 and CKE0 bits in the serial control register (SCR).

Bit 7 GM	Description
0	<p>Normal smart card interface mode operation</p> <p>The TEND flag is set 12.5 etu after the beginning of the start bit.</p> <p>Clock output on/off control only. (Initial value)</p>
1	<p>GSM mode smart card interface mode operation</p> <p>The TEND flag is set 11.0 etu after the beginning of the start bit.</p> <p>Clock output on/off and fixed-high/fixed-low control.</p>

**Bits 6 to 0:** These bits operate as in normal serial communication. For details see section 13.2.5, Serial Mode Register (SMR).

### 14.2.4 Serial Control Register (SCR)

The function of SCR bits 1 and 0 is modified in smart card interface mode

Bit	7	6	5	4	3	2	1	0
	TIE	RIE	TE	RE	MPIE	TEIE	CKE1	CKE0
Initial value	0	0	0	0	0	0	0	0
Read/Write	R/W	R/W	R/W	R/W	R/W	R/W	R/W	R/W

**Bits 7 to 2:** These bits operate as in normal serial communication. For details see section 13.2.6, Serial Control Register (SCR).

**Bits 1 and 0—Clock Enable 1 and 0 (CKE1, CKE0):** These bits select the SCI clock source and enable or disable clock output from the SCK pin. In smart card interface mode, it is possible to specify a fixed high level or fixed low level for the clock output, in addition to the usual switching between enabling and disabling of the clock output.

Bit 7 GM	Bit 1 CKE1	Bit 0 CKE0	Description
0	0	0	Internal clock/SCK pin is I/O port (Initial value)
		1	Internal clock/SCK pin is clock output
1	0	0	Internal clock/SCK pin is fixed at low output
		1	Internal clock/SCK pin is clock output
	1	0	Internal clock/SCK pin is fixed at high output
		1	Internal clock/SCK pin is clock output

## 14.3 Operation

### 14.3.1 Overview

The main features of the smart card interface are as follows.

- One frame consists of 8-bit data plus a parity bit.
- In transmission, a guard time of at least 2 etu (elementary time units: the time for transfer of one bit) is provided between the end of the parity bit and the start of the next frame.
- If a parity error is detected during reception, a low error signal level is output for a 1 etu period 10.5 etu after the start bit.



- If an error signal is detected during transmission, the same data is transmitted automatically after the elapse of 2 etu or longer.
- Only asynchronous communication is supported; there is no synchronous communication function.

### 14.3.2 Pin Connections

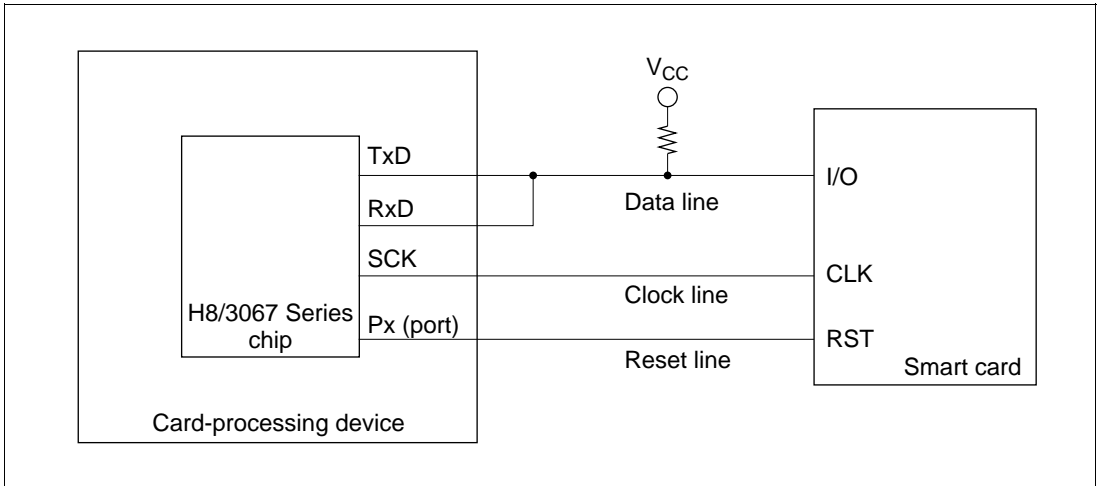
Figure 14.2 shows a pin connection diagram for the smart card interface.

In communication with a smart card, since both transmission and reception are carried out on a single data transmission line, the TxD pin and RxD pin should both be connected to this line. The data transmission line should be pulled up to  $V_{CC}$  with a resistor.

When the smart card uses the clock generated on the smart card interface, the SCK pin output is input to the CLK pin of the smart card. If the smart card uses an internal clock, this connection is unnecessary.

The reset signal should be output from one of the H8/3067 Series' generic ports.

In addition to these pin connections, power and ground connections will normally also be necessary.

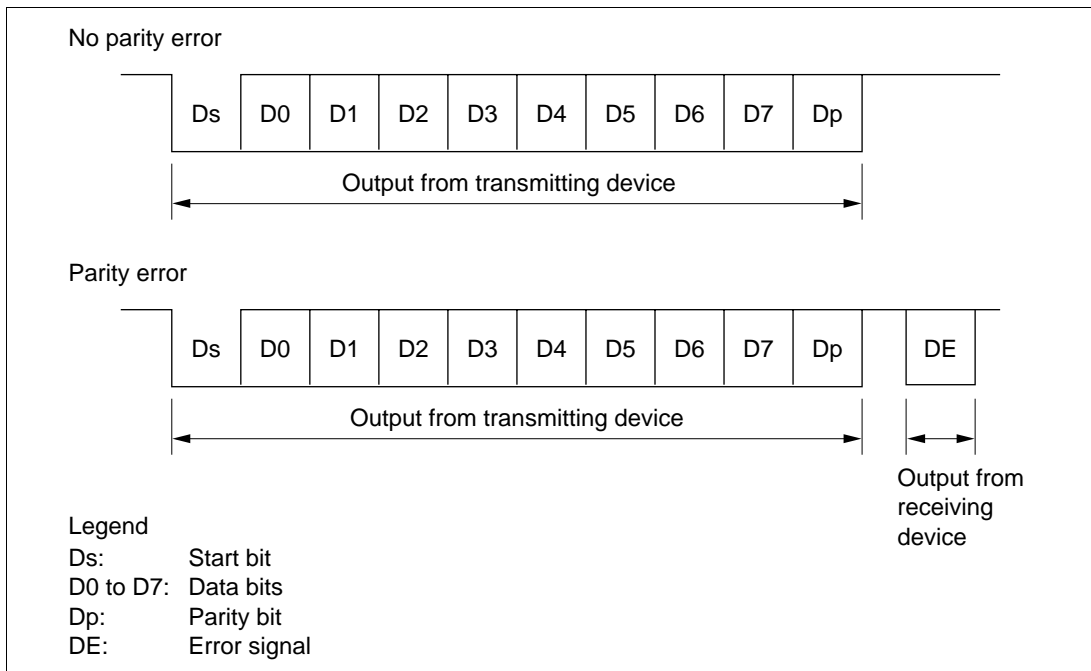


**Figure 14.2 Smart Card Interface Connection Diagram**

Note: A loop-back test can be performed by setting both RE and TE to 1 without connecting a smart card.

### 14.3.3 Data Format

Figure 14.3 shows the smart card interface data format. In reception in this mode, a parity check is carried out on each frame, and if an error is detected an error signal is sent back to the transmitting device to request retransmission of the data. In transmission, the error signal is sampled and the same data is retransmitted if the error signal is low.



**Figure 14.3 Smart Card Interface Data Format**

The operating sequence is as follows.

1. When the data line is not in use it is in the high-impedance state, and is fixed high with a pull-up resistor.
2. The transmitting device starts transfer of one frame of data. The data frame starts with a start bit (Ds, low-level), followed by 8 data bits (D0 to D7) and a parity bit (Dp).
3. With the smart card interface, the data line then returns to the high-impedance state. The data line is pulled high with a pull-up resistor.
4. The receiving device carries out a parity check. If there is no parity error and the data is received normally, the receiving device waits for reception of the next data. If a parity error occurs, however, the receiving device outputs an error signal (DE, low-level) to request retransmission of the data. After outputting the error signal for the prescribed length of time, the receiving device places the signal line in the high-impedance state again. The signal line is pulled high again by a pull-up resistor.

5. If the transmitting device does not receive an error signal, it proceeds to transmit the next data frame. If it receives an error signal, however, it returns to step 2 and transmits the same data again.

### 14.3.4 Register Settings

Table 14.3 shows a bit map of the registers used in the smart card interface. Bits indicated as 0 or 1 must be set to the value shown. The setting of other bits is described in this section.

**Table 14.3 Smart Card Interface Register Settings**

Register	Address <sup>*1</sup>	Bit							
		Bit 7	Bit 6	Bit 5	Bit 4	Bit 3	Bit 2	Bit 1	Bit 0
SMR	H'FFFB0	GM	0	1	O/E	1	0	CKS1	CKS0
BRR	H'FFFB1	BRR7	BRR6	BRR5	BRR4	BRR3	BRR2	BRR1	BRR0
SCR	H'FFFB2	TIE	RIE	TE	RE	0	0	CKE1 <sup>*2</sup>	CKE0
TDR	H'FFFB3	TDR7	TDR6	TDR5	TDR4	TDR3	TDR2	TDR1	TDR0
SSR	H'FFFB4	TDRE	RDRF	ORER	ERS	PER	TEND	0	0
RDR	H'FFFB5	RDR7	RDR6	RDR5	RDR4	RDR3	RDR2	RDR1	RDR0
SCMR	H'FFFB6	—	—	—	—	SDIR	SINV	—	SMIF

Notes: — Unused bit.

1. Lower 20 bits of the address in advanced mode.
2. When GM is cleared to 0 in SMR, the CKE1 bit must also be cleared to 0.

**Serial Mode Register (SMR) Settings:** Clear the GM bit to 0 when using the normal smart card interface mode, or set to 1 when using GSM mode. Clear the O/ $\bar{E}$  bit to 0 if the smart card is of the direct convention type, or set to 1 if of the inverse convention type.

Bits CKS1 and CKS0 select the clock source of the built-in baud rate generator. See section 14.3.5, Clock.

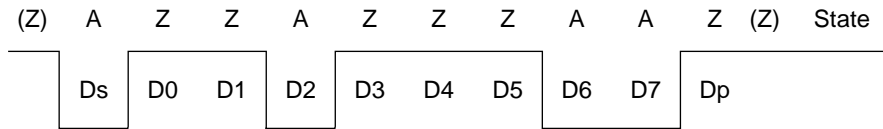
**Bit Rate Register (BRR) Settings:** BRR is used to set the bit rate. See section 14.3.5, Clock, for the method of calculating the value to be set.

**Serial Control Register (SCR) Settings:** The TIE, RIE, TE, and RE bits have their normal serial communication functions. See section 13, Serial Communication Interface, for details. The CKE1 and CKE0 bits specify clock output. To disable clock output, clear these bits to 00; to enable clock output, set these bits to 01. Clock output is not performed when the GM bit is set to 1 in SMR. Clock output can also be fixed low or high.

**Smart Card Mode Register (SCMR) Settings:** Clear both the SDIR bit and SINV bit cleared to 0 if the smart card is of the direct convention type, and set both to 1 if of the inverse convention type. To use the smart card interface, set the SMIF bit to 1.

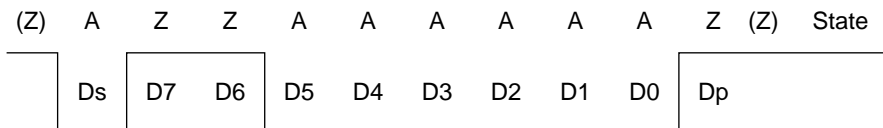
The register settings and examples of starting character waveforms are shown below for two smart cards, one following the direct convention and one the inverse convention.

1. Direct Convention ( $SDIR = SINV = O/\bar{E} = 0$ )



With the direct convention type, the logic 0 level corresponds to state Z and the logic 1 level to state A, and transfer is performed in LSB-first order. In the example above, the first character data is H'3B. The parity bit is 1, following the even parity rule designated for smart cards.

2. Indirect Convention ( $SDIR = SINV = O/\bar{E} = 1$ )



With the indirect convention type, the logic 1 level corresponds to state Z and the logic 0 level to state A, and transfer is performed in MSB-first order. In the example above, the first character data is H'3F. The parity bit is 0, corresponding to state Z, following the even parity rule designated for smart cards.

In the H8/3067 Series, inversion specified by the SINV bit applies only to the data bits, D7 to D0. For parity bit inversion, the  $O/\bar{E}$  bit in SMR must be set to odd parity mode. This applies to both transmission and reception.

### 14.3.5 Clock

Only an internal clock generated by the on-chip baud rate generator can be used as the transmit/receive clock for the smart card interface. The bit rate is set with the bit rate register (BRR) and the CKS1 and CKS0 bits in the serial mode register (SMR). The equation for calculating the bit rate is shown below. Table 14.5 shows some sample bit rates.

If clock output is selected with CKE0 set to 1, a clock with a frequency of 372 times the bit rate is output from the SCK pin.

$$B = \frac{\phi}{1488 \times 2^{2n-1} \times (N + 1)} \times 10^6$$

where, N: BRR setting (0 N 255)

B: Bit rate (bit/s)

$\phi$ : Operating frequency (MHz)

n: See table 14.4

**Table 14.4 n-Values of CKS1 and CKS0 Settings**

n	CKS1	CKS0
0	0	0
1		1
2	1	0
3		1

Note:\* If the gear function is used to divide the clock frequency, use the divided frequency to calculate the bit rate. The equation above applies directly to 1/1 frequency division.

**Table 14.5 Bit Rates (bits/s) for Various BRR Settings (When n = 0)**

N	$\phi$ (MHz)						
	7.1424	10.00	10.7136	13.00	14.2848	16.00	18.00
0	9600.0	13440.9	14400.0	17473.1	19200.0	21505.4	24193.5
1	4800.0	6720.4	7200.0	8736.6	9600.0	10752.7	12096.8
2	3200.0	4480.3	4800.0	5824.4	6400.0	7168.5	8064.5

Note: Bit rates are rounded off to one decimal place.

The following equation calculates the bit rate register (BRR) setting from the operating frequency and bit rate. N is an integer from 0 to 255, specifying the value with the smaller error.

$$N = \frac{\phi}{1488 \times 2^{2n-1} \times B} \times 10^6 - 1$$

**Table 14.6 BRR Settings for Typical Bit Rates (bits/s) (When n = 0)**

bit/s	$\phi$ (MHz)													
	7.1424		10.00		10.7136		13.00		14.2848		16.00		18.00	
	N	Error	N	Error	N	Error	N	Error	N	Error	N	Error	N	Error
9600	0	0.00	1	30	1	25	1	8.99	1	0.00	1	12.01	2	15.99

**Table 14.7 Maximum Bit Rates for Various Frequencies (Smart Card Interface Mode)**

$\phi$ (MHz)	Maximum Bit Rate (bits/s)	N	n
7.1424	9600	0	0
10.00	13441	0	0
10.7136	14400	0	0
13.00	17473	0	0
14.2848	19200	0	0
16.00	21505	0	0
18.00	24194	0	0

The bit rate error is given by the following equation:

$$\text{Error (\%)} = \left( \frac{\phi}{1488 \times 2^{2n-1} \times B \times (N + 1)} \times 10^6 - 1 \right) \times 100$$

## 14.3.6 Transmitting and Receiving Data

**Initialization:** Before transmitting or receiving data, the smart card interface must be initialized as described below. Initialization is also necessary when switching from transmit mode to receive mode, or vice versa.

1. Clear the TE and RE bits to 0 in the serial control register (SCR).
2. Clear error flags FER/ERS, PER, and ORER to 0 in the serial status register (SSR).
3. Set the parity bit ( $O/\bar{E}$ ) and baud rate generator select bits (CKS1 and CKS0) in the serial mode register (SMR). Clear the  $C/\bar{A}$ , CHR, and MP bits to 0, and set the STOP and PE bits to 1.
4. Set the SMIF, SDIR, and SINV bits in the smart card mode register (SCMR).

When the SMIF bit is set to 1, the TxD pin and RxD pin are both switched from port to SCI pin functions and go to the high-impedance state.

5. Set a value corresponding to the desired bit rate in the bit rate register (BRR).
6. Set the CKE0 bit in SCR. Clear the TIE, RIE, TE, RE, MPIE, TEIE, and CKE1 bits to 0. If the CKE0 bit is set to 1, the clock is output from the SCK pin.
7. Wait at least one bit interval, then set the TIE, RIE, TE, and RE bits in SCR. Do not set the TE bit and RE bit at the same time, except for self-diagnosis.

**Transmitting Serial Data:** As data transmission in smart card mode involves error signal sampling and retransmission processing, the processing procedure is different from that for the normal SCI. Figure 14.5 shows a sample transmission processing flowchart.

1. Perform smart card interface mode initialization as described in Initialization above.
2. Check that the FER/ERS error flag is cleared to 0 in SSR.
3. Repeat steps 2 and 3 until it can be confirmed that the TEND flag is set to 1 in SSR.
4. Write the transmit data in TDR, clear the TDRE flag to 0, and perform the transmit operation. The TEND flag is cleared to 0.
5. To continue transmitting data, go back to step 2.
6. To end transmission, clear the TE bit to 0.

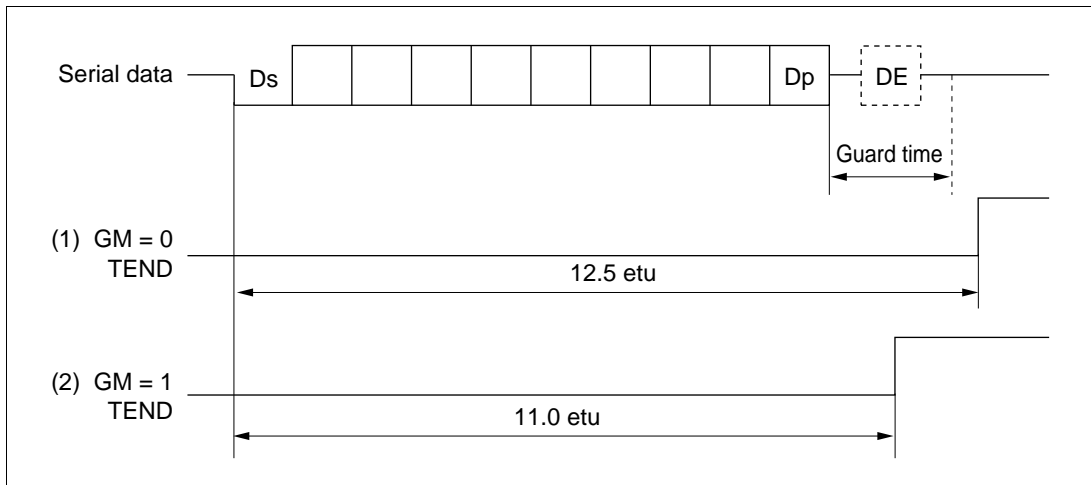
The above processing may include interrupt handling DMA transfer.

If transmission ends and the TEND flag is set to 1 while the TIE bit is set to 1 and interrupt requests are enabled, a transmit-data-empty interrupt (TXI) will be requested. If an error occurs in transmission and the ERS flag is set to 1 while the RIE bit is set to 1 and interrupt requests are enabled, a transmit/receive-error interrupt (ERI) will be requested.

The timing of TEND flag setting depends on the GM bit in SMR (see figure 14.4).

If the TXI interrupt activates the DMAC, the number of bytes designated in the DMAC can be transmitted automatically, including automatic retransmission.

For details, see Interrupt Operations and Data Transfer by DMAC in this section.



**Figure 14.4 Timing of TEND Flag Setting**



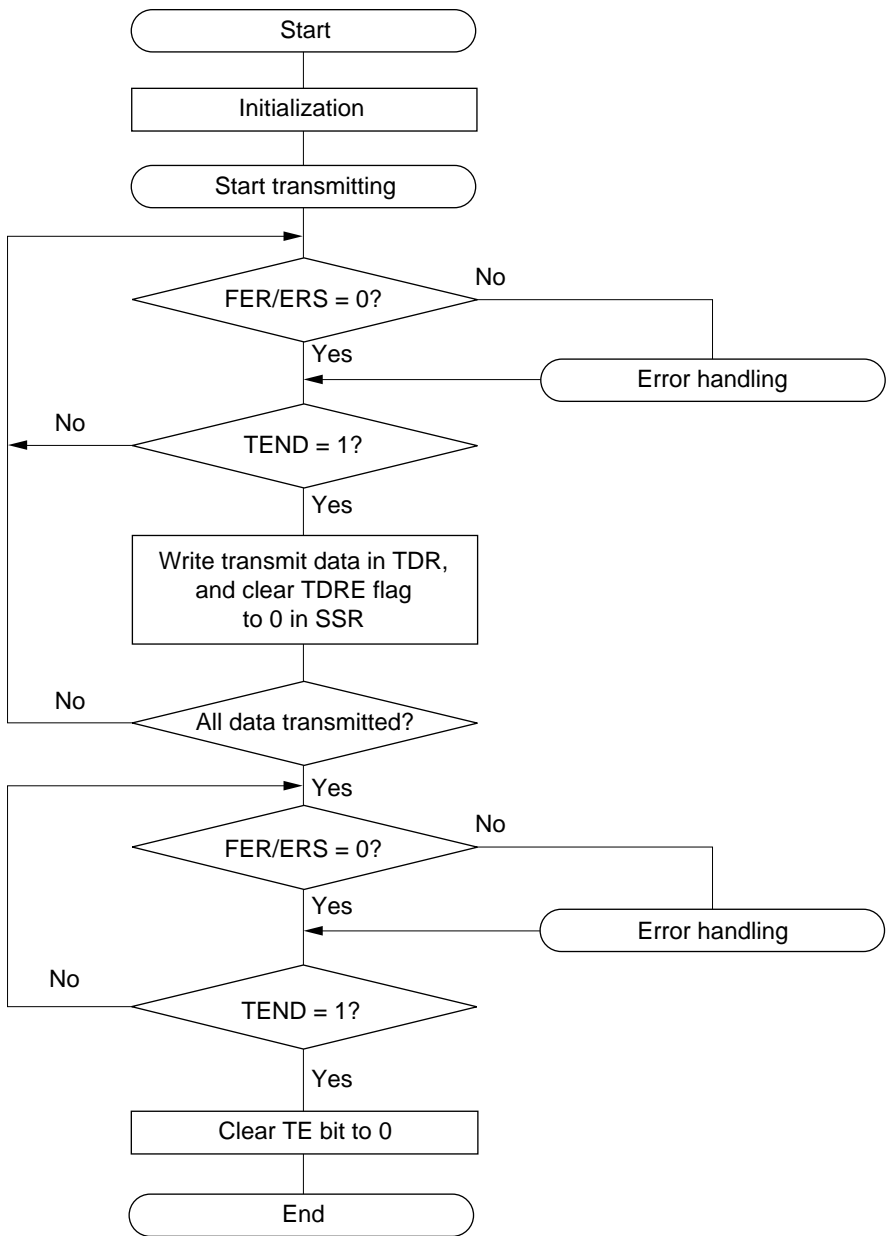
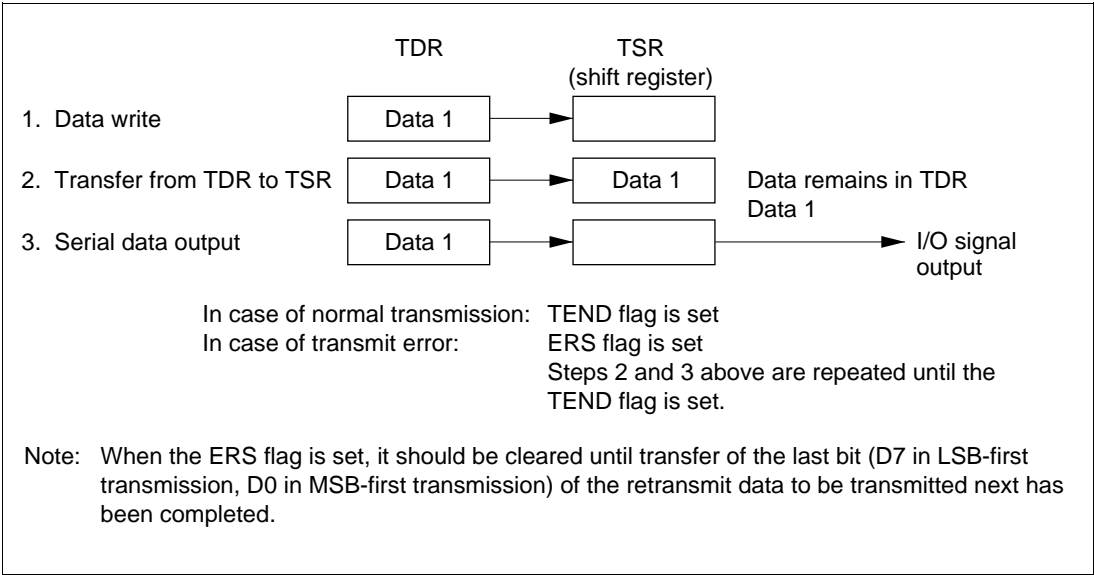
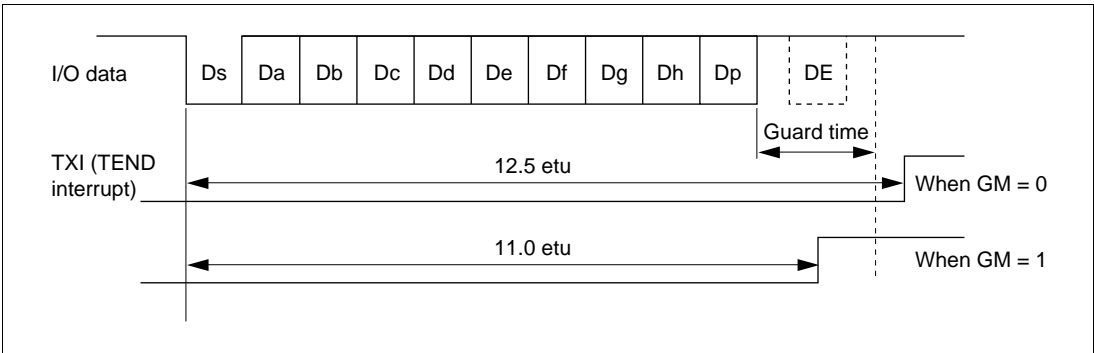


Figure 14.5 Sample Transmission Processing Flowchart



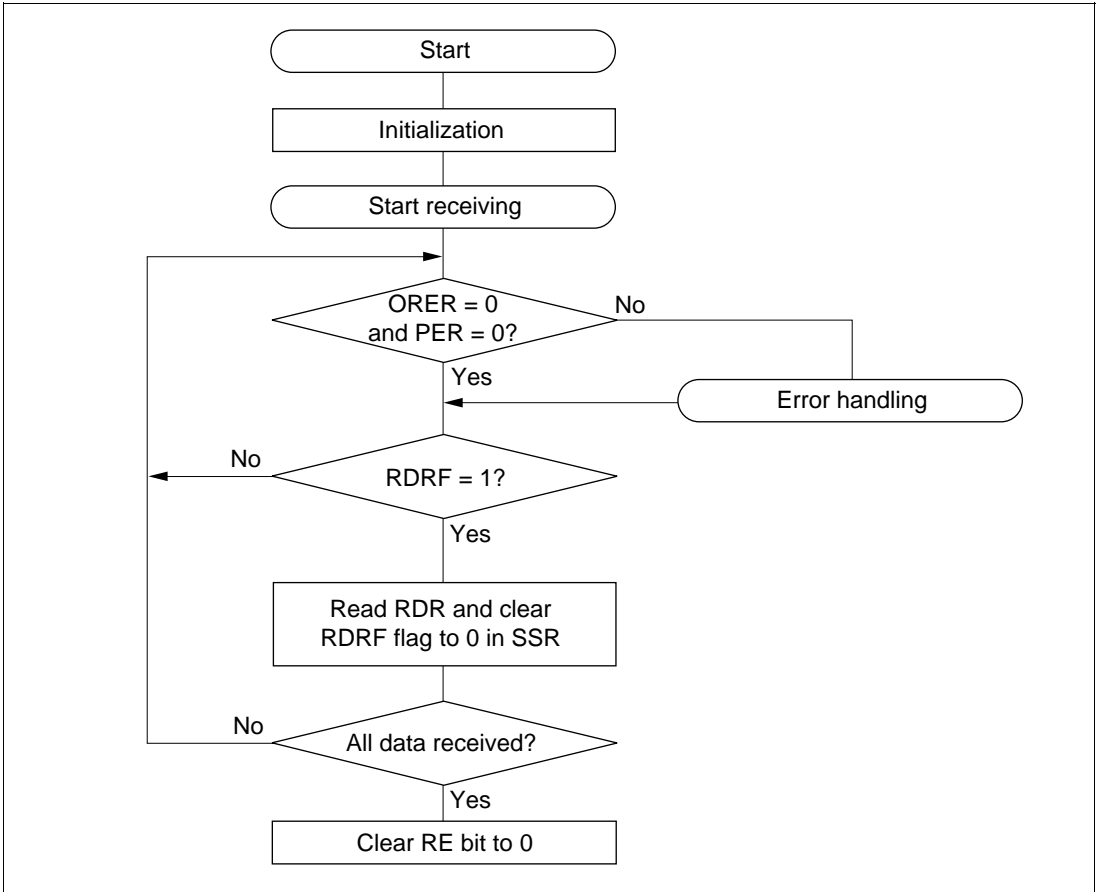
**Figure 14.6 Relation Between Transmit Operation and Internal Registers**



**Figure 14.7 Timing of TEND Flag Setting**

**Receiving Serial Data:** Data reception in smart card mode uses the same processing procedure as for the normal SCI. Figure 14.8 shows a sample reception processing flowchart.

1. Perform smart card interface mode initialization as described in Initialization above.
2. Check that the ORER flag and PER flag are cleared to 0 in SSR. If either is set, perform the appropriate receive error handling, then clear both the ORER and the PER flag to 0.
3. Repeat steps 2 and 3 until it can be confirmed that the RDRF flag is set to 1.
4. Read the receive data from RDR.
5. To continue receiving data, clear the RDRF flag to 0 and go back to step 2.
6. To end reception, clear the RE bit to 0.



**Figure 14.8 Sample Reception Processing Flowchart**

The above procedure may include interrupt handling and DMA transfer.

If reception ends and the RDRF flag is set to 1 while the RIE bit is set to 1 and interrupt requests are enabled, a receive-data-full interrupt (RXI) will be requested. If an error occurs in reception and either the ORER flag or the PER flag is set to 1, a transmit/receive-error interrupt (ERI) will be requested.

If the RXI interrupt activates the DMAC, the number of bytes designated in the DMAC will be transferred, skipping receive data in which an error occurred.

For details, see Interrupt Operations and Data Transfer by DMAC in this section.

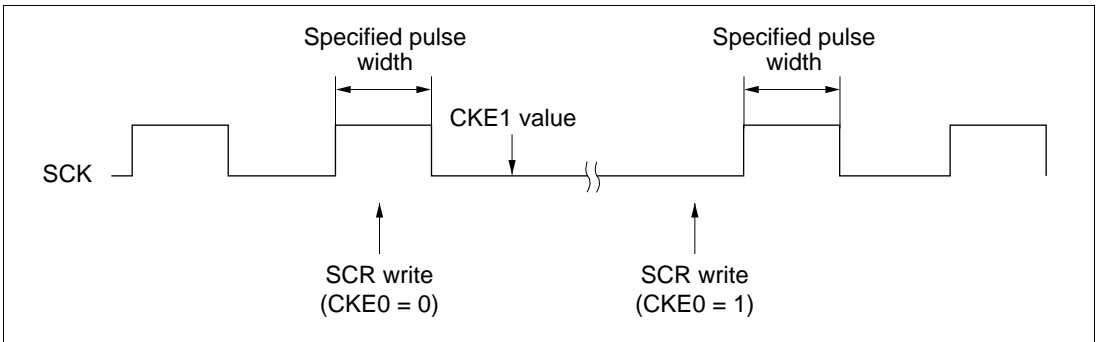
If a parity error occurs during reception and the PER flag is set to 1, the received data is transferred to RDR, so the erroneous data can be read.

**Switching Modes:** When switching from receive mode to transmit mode, first confirm that the receive operation has been completed, then start from initialization, clearing RE to 0 and setting TE to 1. The RDRF, PER, or ORER flag can be used to check that the receive operation has been completed.

When switching from transmit mode to receive mode, first confirm that the transmit operation has been completed, then start from initialization, clearing TE to 0 and setting RE to 1. The TEND flag can be used to check that the transmit operation has been completed.

**Fixing Clock Output:** When the GM bit is set to 1 in SMR, clock output can be fixed by means of the CKE1 and CKE0 bits in SCR. The minimum clock pulse width can be set to the specified width in this case.

Figure 14.9 shows the timing for fixing clock output. In this example, GM = 1, CKE1 = 0, and the CKE0 bit is controlled.



**Figure 14.9 Timing for Fixing Clock Output**

**Interrupt Operations:** The smart card interface has three interrupt sources: transmit-data-empty (TXI), transmit/receive-error (ERI), and receive-data-full (RXI). The transmit-end interrupt request (TEI) is not available in smart card mode.

A TXI interrupt is requested when the TEND flag is set to 1 in SSR. An RXI interrupt is requested when the RDRF flag is set to 1 in SSR. An ERI interrupt is requested when the ORER, PER, or ERS flag is set to 1 in SSR. These relationships are shown in table 14.8.

**Table 14.8 Smart Card Interface Mode Operating States and Interrupt Sources**

Operating State		Flag	Enable Bit	Interrupt Source	DMAC Activation
Transmit Mode	Normal operation	TEND	TIE	TXI	Available
	Error	ERS	RIE	ERI	Not available
Receive Mode	Normal operation	RDRF	RIE	RXI	Available
	Error	PER, ORER	RIE	ERI	Not available

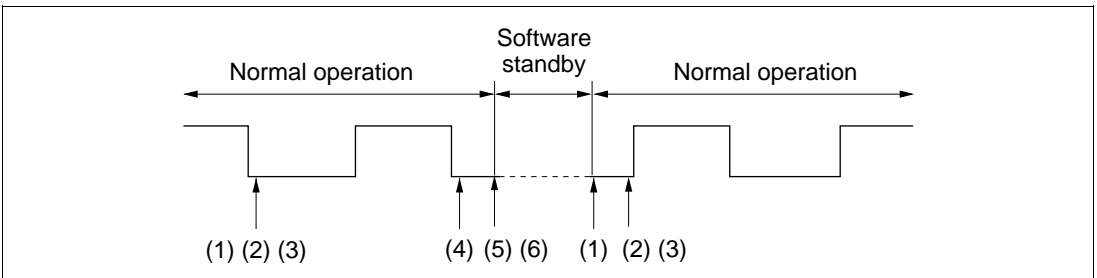
**Data Transfer by DMAC:** The DMAC can be used to transmit and receive data in smart card mode, as in normal SCI operations. In transmit mode, when the TEND flag is set to 1 in SSR, the TDRE flag is set simultaneously, generating a TXI interrupt. If the TXI request is designated beforehand as a DMAC activation source, the DMAC will be activated by the TXI request and will transfer the next transmit data. This data transfer by the DMAC automatically clears the TDRE and TEND flags to 0. In the event of an error, the SCI automatically retransmits the same data, keeping the TEND flag cleared to 0 so that the DMAC is not activated. The SCI and DMAC will therefore automatically transmit the designated number of bytes, including retransmission when an error occurs. When an error occurs, the ERS flag is not cleared automatically, so the RIE bit should be set to 1 to enable the error to generate an ERI request, and the ERI interrupt handler should clear ERS.

When using the DMAC to transmit or receive, first set up and enable the DMAC, then make SCI settings. DMAC settings are described in section 7, DMA controller.

In receive operations, an RXI interrupt is requested when the RDRF flag is set to 1 in SSR. If the RXI request is designated beforehand as a DMAC activation source, the DMAC will be activated by the RXI request and will transfer the received data. This data transfer by the DMAC automatically clears the RDRF flag to 0. When an error occurs, the RDRF flag is not set and an error flag is set instead. The DMAC is not activated. The ERI interrupt request is directed to the CPU. The ERI interrupt handler should clear the error flags.

**Examples of Operation in GSM Mode:** When switching between smart card interface mode and software standby mode, use the following procedures to maintain the clock duty cycle.

- Switching from smart card interface mode to software standby mode
  1. Set the P9<sub>4</sub> data register (DR) and data direction register (DDR) to the values for the fixed output state in software standby mode.
  2. Write 0 in the TE and RE bits in the serial control register (SCR) to stop transmit/receive operations. At the same time, set the CKE1 bit to the value for the fixed output state in software standby mode.
  3. Write 0 in the CKE0 bit in SCR to stop the clock.
  4. Wait for one serial clock cycle. During this period, the duty cycle is preserved and clock output is fixed at the specified level.
  5. Write H'00 in the serial mode register (SMR) and smart card mode register (SCMR).
  6. Make the transition to the software standby state.
- Returning from software standby mode to smart card interface mode
  1. Clear the software standby state.
  2. Set the CKE1 bit in SCR to the value for the fixed output state at the start of software standby (the current P9<sub>4</sub> pin state).
  3. Set smart card interface mode and output the clock. Clock signal generation is started with the normal duty cycle.



**Figure 14.10 Procedure for Stopping and Restarting the Clock**

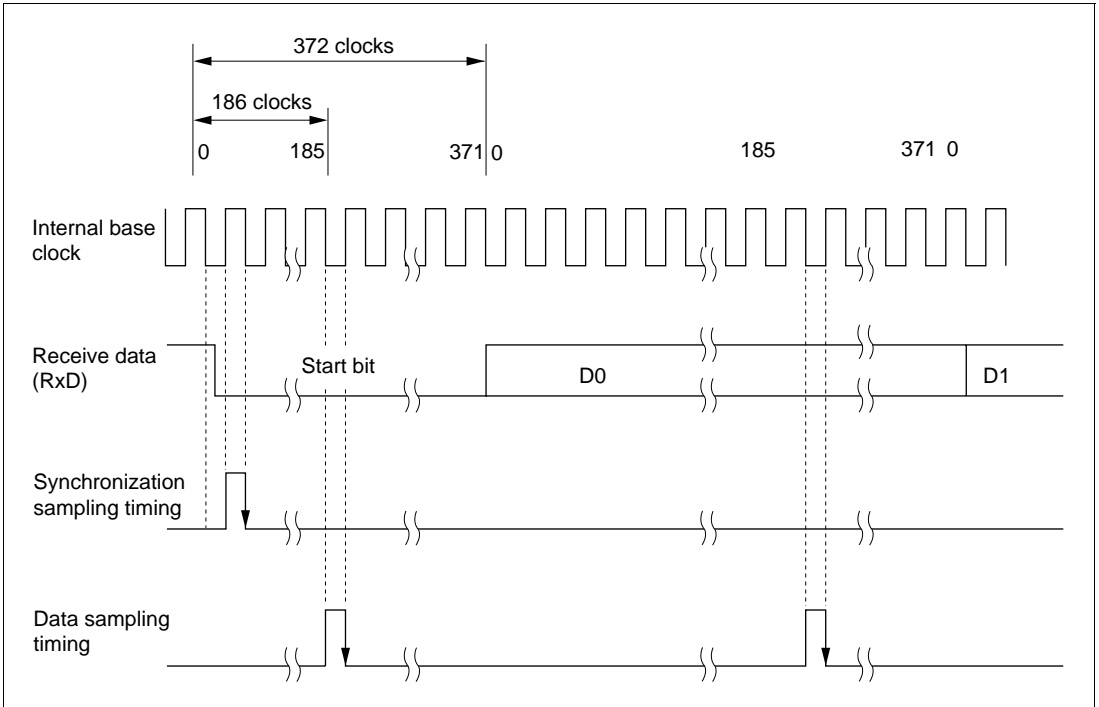
Use the following procedure to secure the clock duty cycle after powering on.

1. The initial state is port input and high impedance. Use pull-up or pull-down resistors to fix the potential.
2. Fix at the output specified by the CKE1 bit in SCR.
3. Set SMR and SCMR, and switch to smart card interface mode operation.
4. Set the CKE0 bit to 1 in SCR to start clock output.

## 14.4 Usage Notes

The following points should be noted when using the SCI as a smart card interface.

**Receive Data Sampling Timing and Receive Margin in Smart Card Interface Mode:** In smart card interface mode, the SCI operates on a base clock with a frequency of 372 times the transfer rate. In reception, the SCI synchronizes internally with the fall of the start bit, which it samples on the base clock. Receive data is latched at the rising edge of the 186th base clock pulse. The timing is shown in figure 14.11.



**Figure 14.11 Receive Data Sampling Timing in Smart Card Interface Mode**

The receive margin can therefore be expressed as follows.

Receive margin in smart card interface mode:

$$M = \left| \left( 0.5 - \frac{1}{2N} \right) - (L - 0.5) F - \frac{|D - 0.5|}{N} (1 + F) \right| \times 100\%$$

M: Receive margin (%)

N: Ratio of clock frequency to bit rate (N = 372)

D: Clock duty cycle (L = 0 to 1.0)

L: Frame length (L = 10)

F: Absolute deviation of clock frequency

From the above equation, if F = 0 and D = 0.5, the receive margin is as follows.

When D = 0.5 and F = 0:

$$\begin{aligned} M &= (0.5 - 1/2 \times 372) \times 100\% \\ &= 49.866\% \end{aligned}$$

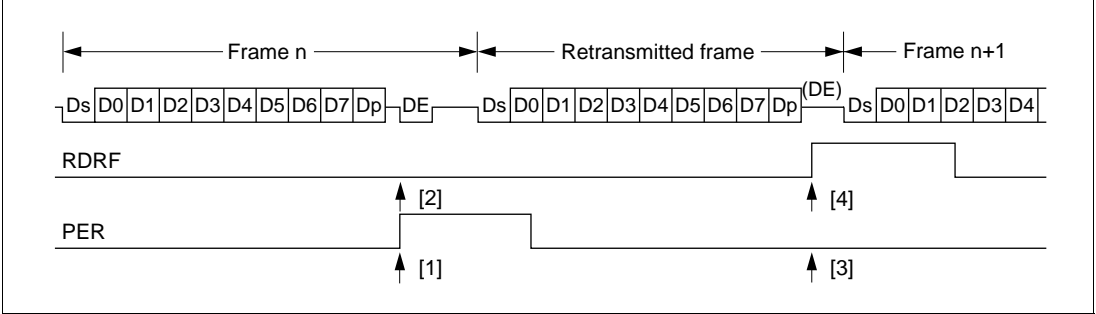
**Retransmission:** Retransmission is performed by the SCI in receive mode and transmit mode as described below.

- Retransmission when SCI is in Receive Mode

Figure 14.12 illustrates retransmission when the SCI is in receive mode.

1. If an error is found when the received parity bit is checked, the PER bit is automatically set to 1. If the RIE bit in SCR is set to the enable state, an ERI interrupt is requested. The PER bit should be cleared to 0 in SSR before the next parity bit sampling timing.
2. The RDRF bit in SSR is not set for the frame in which the error has occurred.
3. If no error is found when the received parity bit is checked, the PER bit is not set to 1 in SSR.
4. If no error is found when the received parity bit is checked, the receive operation is assumed to have been completed normally, and the RDRF bit is automatically set to 1 in SSR. If the RIE bit in SCR is set to the enable state, an RXI interrupt is requested. If RXI is enabled as a DMA transfer activation source, the RDR contents can be read automatically. When the DMAC reads the RDR data, the RDRF flag is automatically cleared to 0.
5. When a normal frame is received, the data pin is held in the high-impedance state at the error signal transmission timing.



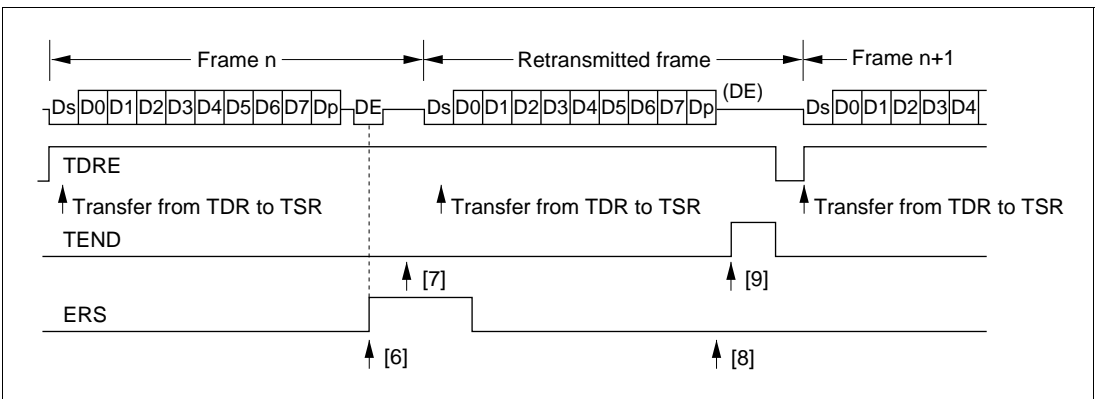


**Figure 14.12 Retransmission in SCI Receive Mode**

- Retransmission when SCI is in Transmit Mode

Figure 14.13 illustrates retransmission when the SCI is in transmit mode.

6. If an error signal is sent back from the receiving device after transmission of one frame is completed, the FER/ERS bit is set to 1 in SSR. If the RIE bit in SCR is set to the enable state, an ERI interrupt is requested. The ERS bit should be cleared to 0 in SSR before the next parity bit sampling timing.
7. The TEND bit in SSR is not set for the frame for which the error signal was received.
8. If an error signal is not sent back from the receiving device, the ERS flag is not set in SSR.
9. If an error signal is not sent back from the receiving device, transmission of one frame, including retransmission, is assumed to have been completed, and the TEND bit is set to 1 in SSR. If the TIE bit in SCR is set to the enable state, a TXI interrupt is requested. If TXI is enabled as a DMA transfer activation source, the next data can be written in TDR automatically. When the DMAC writes data in TDR, the TDRE bit is automatically cleared to 0.



**Figure 14.13 Retransmission in SCI Transmit Mode**



# Section 15 A/D Converter

## 15.1 Overview

The H8/3067 Series includes a 10-bit successive-approximations A/D converter with a selection of up to eight analog input channels.

When the A/D converter is not used, it can be halted independently to conserve power. For details see section 20.6, Module Standby Function.

### 15.1.1 Features

A/D converter features are listed below.

- 10-bit resolution
- Eight input channels
- Selectable analog conversion voltage range  
The analog voltage conversion range can be programmed by input of an analog reference voltage at the  $V_{REF}$  pin.
- High-speed conversion  
Conversion time: maximum 3.5  $\mu$ s per channel (with 20 MHz system clock)
- Two conversion modes  
Single mode: A/D conversion of one channel  
Scan mode: continuous conversion on one to four channels
- Four 16-bit data registers  
A/D conversion results are transferred for storage into data registers corresponding to the channels.
- Sample-and-hold function
- Three conversion start sources  
The A/D converter can be activated by software, an external trigger, or an 8-bit timer compare match.
- A/D interrupt requested at end of conversion  
At the end of A/D conversion, an A/D end interrupt (ADI) can be requested.
- DMA controller (DMAC) activation  
The DMAC can be activated at the end of A/D conversion.

## 15.1.2 Block Diagram

Figure 15.1 shows a block diagram of the A/D converter.

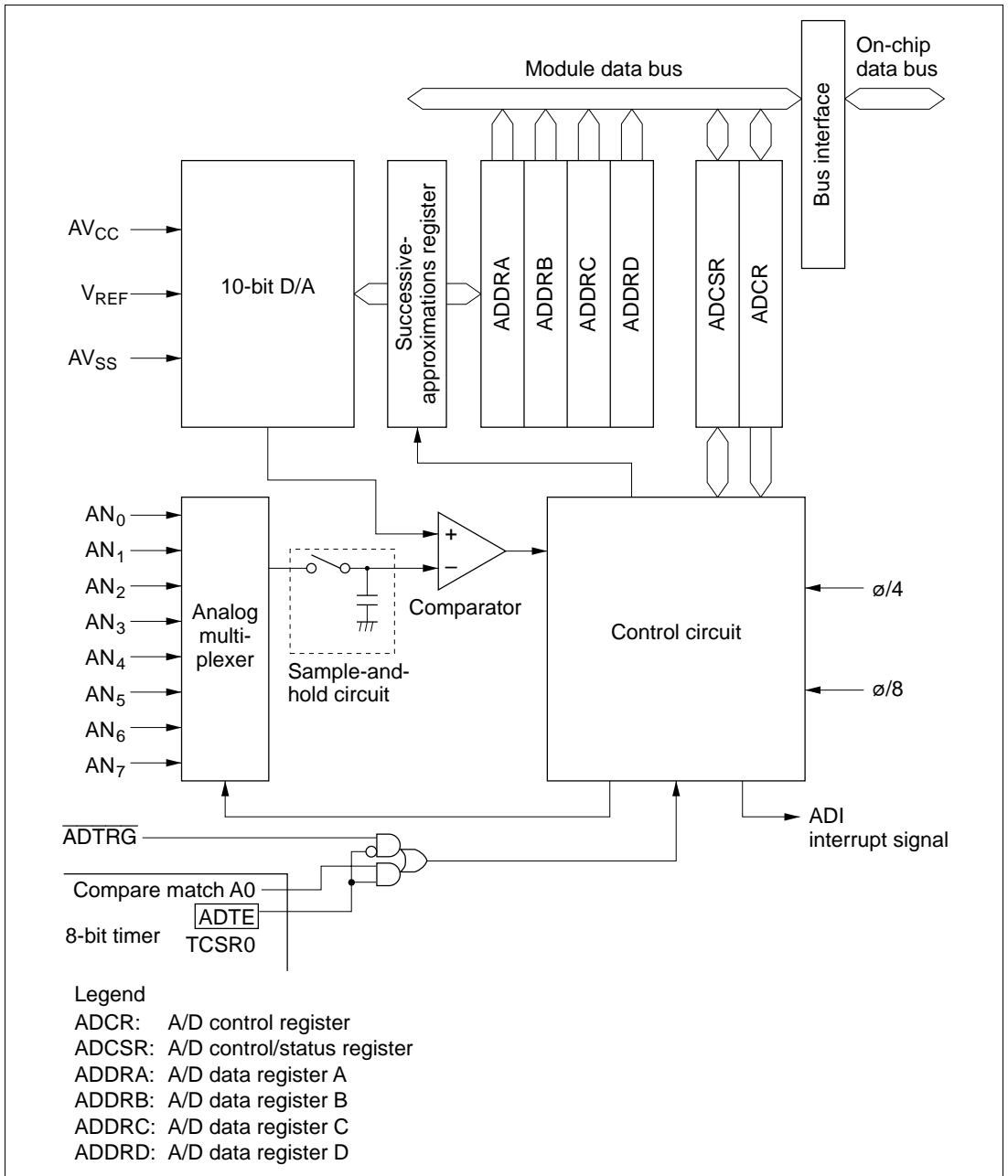


Figure 15.1 A/D Converter Block Diagram

### 15.1.3 Input Pins

Table 15.1 summarizes the A/D converter's input pins. The eight analog input pins are divided into two groups: group 0 ( $AN_0$  to  $AN_3$ ), and group 1 ( $AN_4$  to  $AN_7$ ).  $AV_{CC}$  and  $AV_{SS}$  are the power supply for the analog circuits in the A/D converter.  $V_{REF}$  is the A/D conversion reference voltage.

**Table 15.1 A/D Converter Pins**

Pin Name	Abbreviation	I/O	Function
Analog power supply pin	$AV_{CC}$	Input	Analog power supply
Analog ground pin	$AV_{SS}$	Input	Analog ground and reference voltage
Reference voltage pin	$V_{REF}$	Input	Analog reference voltage
Analog input pin 0	$AN_0$	Input	Group 0 analog inputs
Analog input pin 1	$AN_1$	Input	
Analog input pin 2	$AN_2$	Input	
Analog input pin 3	$AN_3$	Input	
Analog input pin 4	$AN_4$	Input	Group 1 analog inputs
Analog input pin 5	$AN_5$	Input	
Analog input pin 6	$AN_6$	Input	
Analog input pin 7	$AN_7$	Input	
A/D external trigger input pin	$\overline{ADTRG}$	Input	External trigger input for starting A/D conversion

## 15.1.4 Register Configuration

Table 15.2 summarizes the A/D converter's registers.

**Table 15.2 A/D Converter Registers**

<b>Address*<sup>1</sup></b>	<b>Name</b>	<b>Abbreviation</b>	<b>R/W</b>	<b>Initial Value</b>
H'FFFE0	A/D data register A H	ADDRAH	R	H'00
H'FFFE1	A/D data register A L	ADDRAL	R	H'00
H'FFFE2	A/D data register B H	ADDRBH	R	H'00
H'FFFE3	A/D data register B L	ADDRBL	R	H'00
H'FFFE4	A/D data register C H	ADDRCH	R	H'00
H'FFFE5	A/D data register C L	ADDRCL	R	H'00
H'FFFE6	A/D data register D H	ADDRDH	R	H'00
H'FFFE7	A/D data register D L	ADDRDL	R	H'00
H'FFFE8	A/D control/status register	ADCSR	R/(W)* <sup>2</sup>	H'00
H'FFFE9	A/D control register	ADCR	R/W	H'7E

- Notes: 1. Lower 20 bits of the address in advanced mode.  
2. Only 0 can be written in bit 7, to clear the flag.

## 15.2 Register Descriptions

### 15.2.1 A/D Data Registers A to D (ADDRA to ADDR D)

Bit	15	14	13	12	11	10	9	8	7	6	5	4	3	2	1	0
ADDRn	AD9	AD8	AD7	AD6	AD5	AD4	AD3	AD2	AD1	AD0	—	—	—	—	—	—
Initial value	0	0	0	0	0	0	0	0	0	0	0	0	0	0	0	0
Read/Write (n = A to D)	R	R	R	R	R	R	R	R	R	R	R	R	R	R	R	R

**A/D conversion data**
**Reserved bits**

10-bit data giving an

A/D conversion result

The four A/D data registers (ADDRA to ADDR D) are 16-bit read-only registers that store the results of A/D conversion.

An A/D conversion produces 10-bit data, which is transferred for storage into the A/D data register corresponding to the selected channel. The upper 8 bits of the result are stored in the upper byte of the A/D data register. The lower 2 bits are stored in the lower byte. Bits 5 to 0 of an A/D data register are reserved bits that are always read as 0. Table 15.3 indicates the pairings of analog input channels and A/D data registers.

The CPU can always read and write the A/D data registers. The upper byte can be read directly, but the lower byte is read through a temporary register (TEMP). For details see section 15.3, CPU Interface.

The A/D data registers are initialized to H'0000 by a reset and in standby mode.

**Table 15.3 Analog Input Channels and A/D Data Registers**

Analog Input Channel		A/D Data Register
Group 0	Group 1	
AN <sub>0</sub>	AN <sub>4</sub>	ADDRA
AN <sub>1</sub>	AN <sub>5</sub>	ADDRB
AN <sub>2</sub>	AN <sub>6</sub>	ADDRC
AN <sub>3</sub>	AN <sub>7</sub>	ADDRD

## 15.2.2 A/D Control/Status Register (ADCSR)

Bit	7	6	5	4	3	2	1	0
	ADF	ADIE	ADST	SCAN	CKS	CH2	CH1	CH0
Initial value	0	0	0	0	0	0	0	0
Read/Write	R/(W)*	R/W	R/W	R/W	R/W	R/W	R/W	R/W

**A/D end flag**  
 Indicates end of A/D conversion

**A/D interrupt enable**  
 Enables and disables A/D end interrupts

**A/D start**  
 Starts or stops A/D conversion

**Scan mode**  
 Selects single mode or scan mode

**Clock select**  
 Selects the A/D conversion time

**Channel select 2 to 0**  
 These bits select analog input channels

Note: \* Only 0 can be written, to clear the flag.

ADCSR is an 8-bit readable/writable register that selects the mode and controls the A/D converter. ADCSR is initialized to H'00 by a reset and in standby mode.



**Bit 7—A/D End Flag (ADF):** Indicates the end of A/D conversion.

Bit 7 ADF	Description	
0	[Clearing condition] Read ADF when ADF =1, then write 0 in ADF. DMAC activated by ADI interrupt.	(Initial value)
1	[Setting conditions] Single mode: A/D conversion ends Scan mode: A/D conversion ends in all selected channels	

**Bit 6—A/D Interrupt Enable (ADIE):** Enables or disables the interrupt (ADI) requested at the end of A/D conversion.

Bit 6 ADIE	Description	
0	A/D end interrupt request (ADI) is disabled	(Initial value)
1	A/D end interrupt request (ADI) is enabled	

**Bit 5—A/D Start (ADST):** Starts or stops A/D conversion. The ADST bit remains set to 1 during A/D conversion. It can also be set to 1 by external trigger input at the  $\overline{\text{ADTRG}}$  pin, or by an 8-bit timer compare match.

Bit 5 ADST	Description	
0	A/D conversion is stopped	(Initial value)
1	Single mode: A/D conversion starts; ADST is automatically cleared to 0 when conversion ends. Scan mode: A/D conversion starts and continues, cycling among the selected channels, until ADST is cleared to 0 by software, by a reset, or by a transition to standby mode.	

**Bit 4—Scan Mode (SCAN):** Selects single mode or scan mode. For further information on operation in these modes, see section 15.4, Operation. Clear the ADST bit to 0 before switching the conversion mode.

Bit 4 SCAN	Description	
0	Single mode	(Initial value)
1	Scan mode	

**Bit 3—Clock Select (CKS):** Selects the A/D conversion time. Clear the ADST bit to 0 before switching the conversion time.

Bit 3 CKS	Description	
0	Conversion time = 134 states (maximum)	(Initial value)
1	Conversion time = 70 states (maximum)	

**Bits 2 to 0—Channel Select 2 to 0 (CH2 to CH0):** These bits and the SCAN bit select the analog input channels. Clear the ADST bit to 0 before changing the channel selection.

Group Selection CH2	Channel Selection		Description	
	CH1	CH0	Single Mode	Scan Mode
0	0	0	AN <sub>0</sub> (Initial value)	AN <sub>0</sub>
		1	AN <sub>1</sub>	AN <sub>0</sub> , AN <sub>1</sub>
	1	0	AN <sub>2</sub>	AN <sub>0</sub> to AN <sub>2</sub>
		1	AN <sub>3</sub>	AN <sub>0</sub> to AN <sub>3</sub>
1	0	0	AN <sub>4</sub>	AN <sub>4</sub>
		1	AN <sub>5</sub>	AN <sub>4</sub> , AN <sub>5</sub>
	1	0	AN <sub>6</sub>	AN <sub>4</sub> to AN <sub>6</sub>
		1	AN <sub>7</sub>	AN <sub>4</sub> to AN <sub>7</sub>

### 15.2.3 A/D Control Register (ADCR)

Bit	7	6	5	4	3	2	1	0
	TRGE	—	—	—	—	—	—	—
Initial value	0	1	1	1	1	1	1	0
Read/Write	R/W	—	—	—	—	—	—	R/W

Reserved bits

#### Trigger enable

Enables or disables starting of A/D conversion by an external trigger or 8-bit timer compare match

ADCR is an 8-bit readable/writable register that enables or disables starting of A/D conversion by external trigger input or an 8-bit timer compare match signal. ADCR is initialized to H'7F by a reset and in standby mode.

**Bit 7—Trigger Enable (TRGE):** Enables or disables starting of A/D conversion by an external trigger or 8-bit timer compare match.

#### Bit 7

TRGE	Description
0	Starting of A/D conversion by an external trigger or 8-bit timer compare match is disabled (Initial value)
1	A/D conversion is started at the falling edge of the external trigger signal (ADTRG) or by an 8-bit timer compare match

External trigger pin and 8-bit timer selection are performed by the 8-bit timer. For details, see section 10, 8-Bit Timers.

**Bits 6 to 1—Reserved:** These bits cannot be modified and are always read as 1.

**Bit 0—Reserved:** This bit can be read or written, but must not be set to 1.

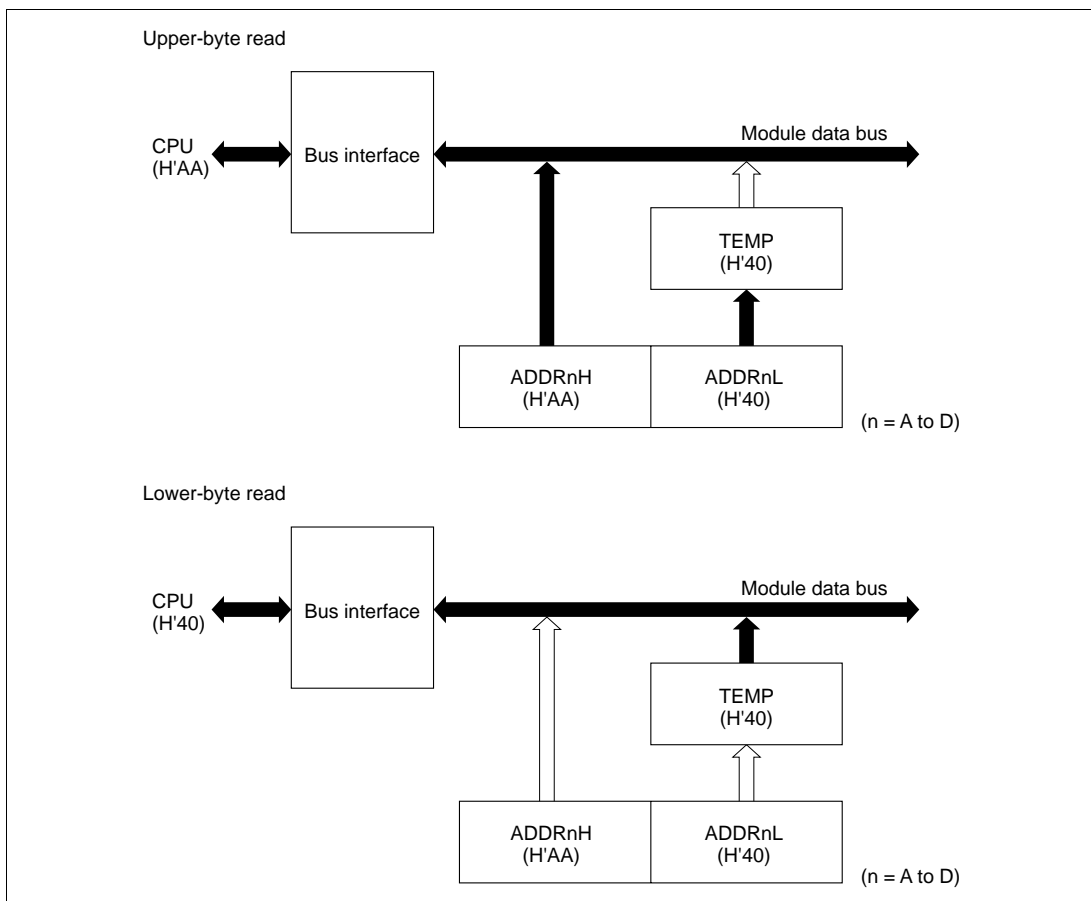
## 15.3 CPU Interface

ADDRA to ADDRD are 16-bit registers, but they are connected to the CPU by an 8-bit data bus. Therefore, although the upper byte can be accessed directly by the CPU, the lower byte is read through an 8-bit temporary register (TEMP).

An A/D data register is read as follows. When the upper byte is read, the upper-byte value is transferred directly to the CPU and the lower-byte value is transferred into TEMP. Next, when the lower byte is read, the TEMP contents are transferred to the CPU.

When reading an A/D data register, always read the upper byte before the lower byte. It is possible to read only the upper byte, but if only the lower byte is read, incorrect data may be obtained.

Figure 15.2 shows the data flow for access to an A/D data register.



**Figure 15.2 A/D Data Register Access Operation (Reading H'AA40)**

## 15.4 Operation

The A/D converter operates by successive approximations with 10-bit resolution. It has two operating modes: single mode and scan mode.

### 15.4.1 Single Mode (SCAN = 0)

Single mode should be selected when only one A/D conversion on one channel is required. A/D conversion starts when the ADST bit is set to 1 by software, or by external trigger input. The ADST bit remains set to 1 during A/D conversion and is automatically cleared to 0 when conversion ends.

When conversion ends the ADF bit is set to 1. If the ADIE bit is also set to 1, an ADI interrupt is requested at this time. To clear the ADF flag to 0, first read ADCSR, then write 0 in ADF.

When the mode or analog input channel must be switched during analog conversion, to prevent incorrect operation, first clear the ADST bit to 0 in ADCSR to halt A/D conversion. After making the necessary changes, set the ADST bit to 1 to start A/D conversion again. The ADST bit can be set at the same time as the mode or channel is changed.

Typical operations when channel 1 ( $AN_1$ ) is selected in single mode are described next.

Figure 15.3 shows a timing diagram for this example.

1. Single mode is selected (SCAN = 0), input channel  $AN_1$  is selected (CH2 = CH1 = 0, CH0 = 1), the A/D interrupt is enabled (ADIE = 1), and A/D conversion is started (ADST = 1).
2. When A/D conversion is completed, the result is transferred into ADDR0. At the same time the ADF flag is set to 1, the ADST bit is cleared to 0, and the A/D converter becomes idle.
3. Since ADF = 1 and ADIE = 1, an ADI interrupt is requested.
4. The A/D interrupt handling routine starts.
5. The routine reads ADCSR, then writes 0 in the ADF flag.
6. The routine reads and processes the conversion result (ADDR0).
7. Execution of the A/D interrupt handling routine ends. After that, if the ADST bit is set to 1, A/D conversion starts again and steps 2 to 7 are repeated.

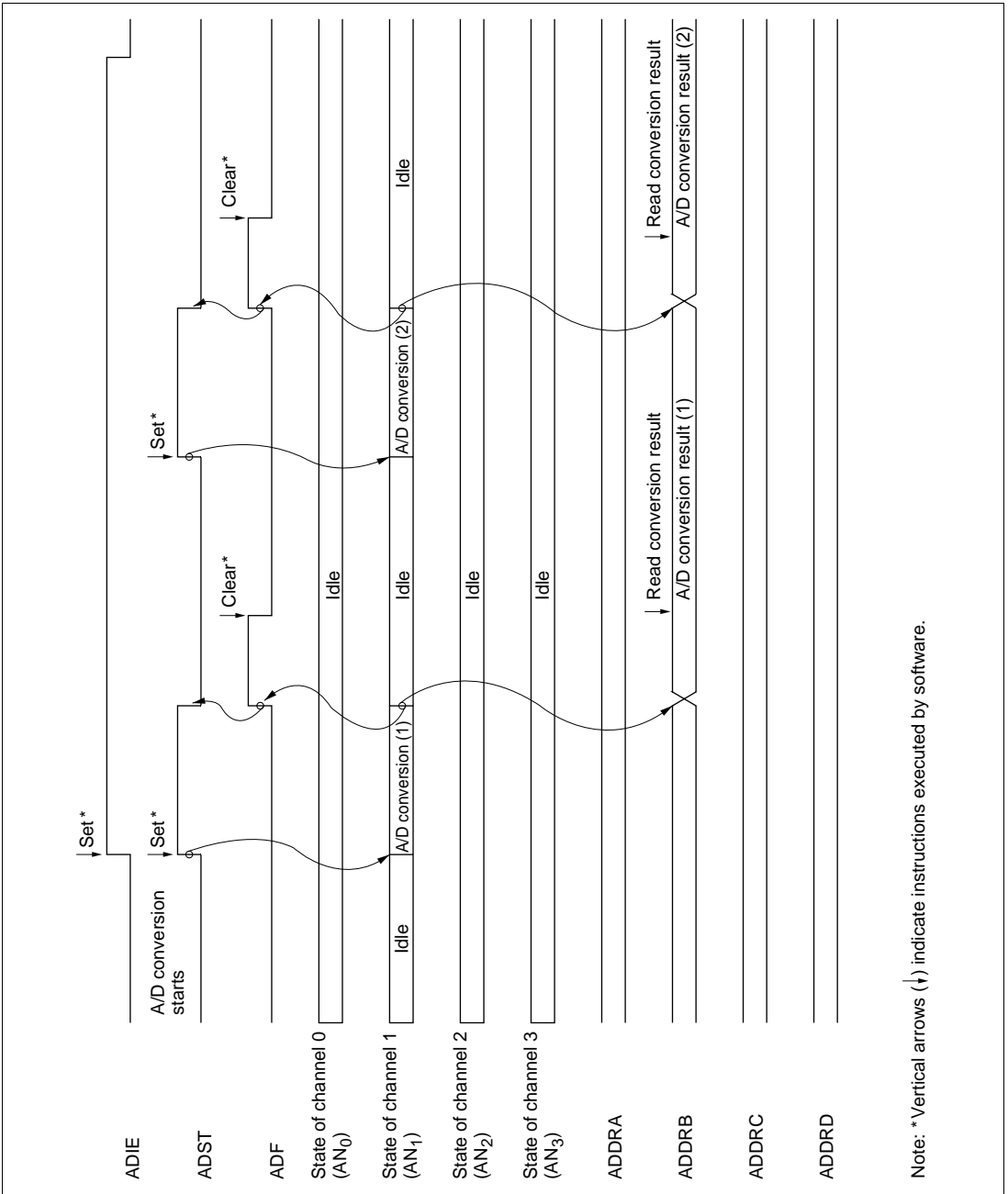


Figure 15.3 Example of A/D Converter Operation (Single Mode, Channel 1 Selected)

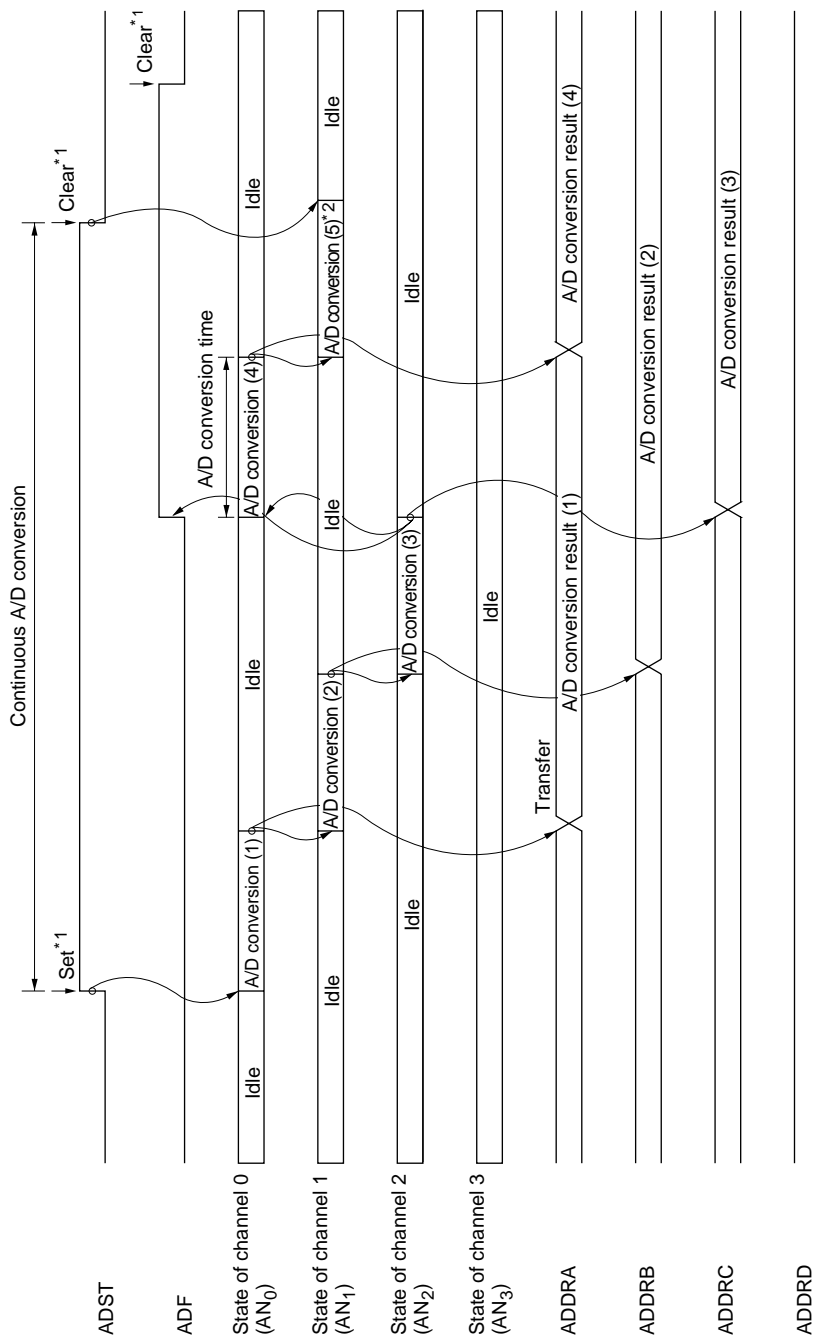
### 15.4.2 Scan Mode (SCAN = 1)

Scan mode is useful for monitoring analog inputs in a group of one or more channels. When the ADST bit is set to 1 by software or external trigger input, A/D conversion starts on the first channel in the group ( $AN_0$  when  $CH2 = 0$ ,  $AN_4$  when  $CH2 = 1$ ). When two or more channels are selected, after conversion of the first channel ends, conversion of the second channel ( $AN_1$  or  $AN_5$ ) starts immediately. A/D conversion continues cyclically on the selected channels until the ADST bit is cleared to 0. The conversion results are transferred for storage into the A/D data registers corresponding to the channels.

When the mode or analog input channel selection must be changed during analog conversion, to prevent incorrect operation, first clear the ADST bit to 0 in ADCSR to halt A/D conversion. After making the necessary changes, set the ADST bit to 1. A/D conversion will start again from the first channel in the group. The ADST bit can be set at the same time as the mode or channel selection is changed.

Typical operations when three channels in group 0 ( $AN_0$  to  $AN_2$ ) are selected in scan mode are described next. Figure 15.4 shows a timing diagram for this example.

1. Scan mode is selected ( $SCAN = 1$ ), scan group 0 is selected ( $CH2 = 0$ ), analog input channels  $AN_0$  to  $AN_2$  are selected ( $CH1 = 1$ ,  $CH0 = 0$ ), and A/D conversion is started ( $ADST = 1$ ).
2. When A/D conversion of the first channel ( $AN_0$ ) is completed, the result is transferred into ADDRA. Next, conversion of the second channel ( $AN_1$ ) starts automatically.
3. Conversion proceeds in the same way through the third channel ( $AN_2$ ).
4. When conversion of all selected channels ( $AN_0$  to  $AN_2$ ) is completed, the ADF flag is set to 1 and conversion of the first channel ( $AN_0$ ) starts again. If the ADIE bit is set to 1, an ADI interrupt is requested at this time.
5. Steps 2 to 4 are repeated as long as the ADST bit remains set to 1. When the ADST bit is cleared to 0, A/D conversion stops. After that, if the ADST bit is set to 1, A/D conversion starts again from the first channel ( $AN_0$ ).



Notes: 1. Vertical arrows (↑) indicate instructions executed by software.  
 2. Data currently being converted is ignored.

**Figure 15.4 Example of A/D Converter Operation (Scan Mode, Channels AN<sub>0</sub> to AN<sub>2</sub> Selected)**



### 15.4.3 Input Sampling and A/D Conversion Time

The A/D converter has a built-in sample-and-hold circuit. The A/D converter samples the analog input at a time  $t_D$  after the ADST bit is set to 1, then starts conversion. Figure 15.5 shows the A/D conversion timing. Table 15.4 indicates the A/D conversion time.

As indicated in figure 15.5, the A/D conversion time includes  $t_D$  and the input sampling time. The length of  $t_D$  varies depending on the timing of the write access to ADCSR. The total conversion time therefore varies within the ranges indicated in table 15.4.

In scan mode, the values given in table 15.4 apply to the first conversion. In the second and subsequent conversions the conversion time is fixed at 128 states when  $CKS = 0$  or 66 states when  $CKS = 1$ .

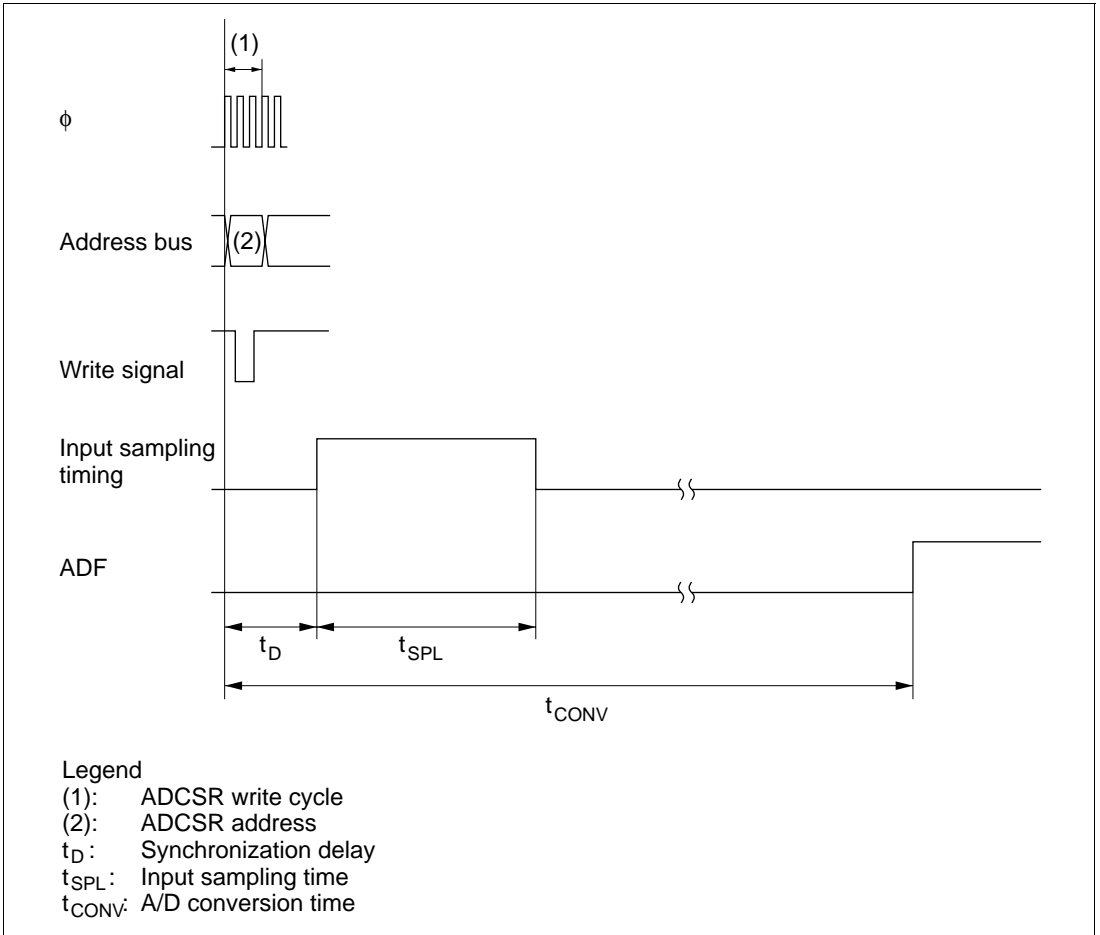


Figure 15.5 A/D Conversion Timing

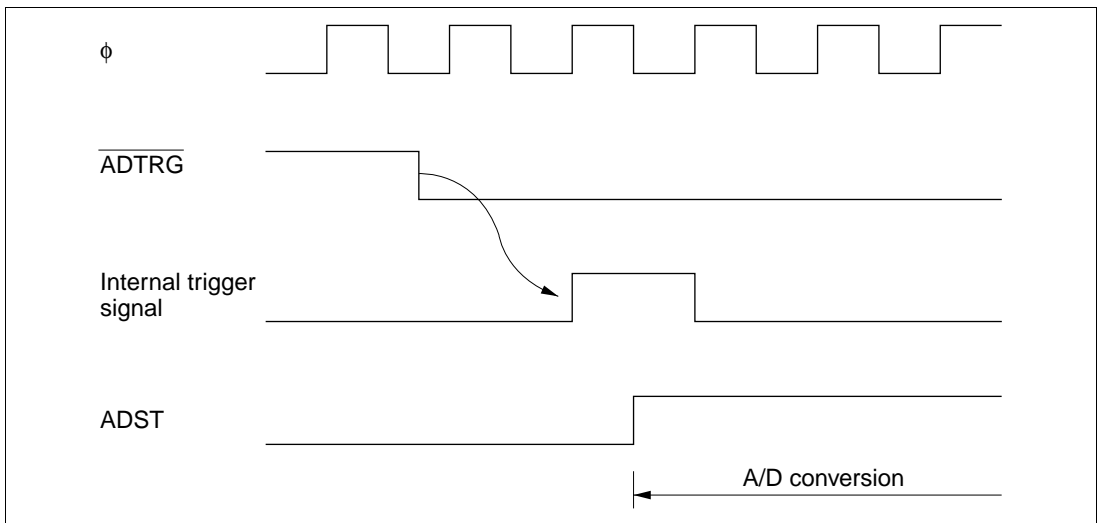
**Table 15.4 A/D Conversion Time (Single Mode)**

	Symbol	CKS = 0			CKS = 1		
		Min	Typ	Max	Min	Typ	Max
Synchronization delay	$t_D$	6	—	9	4	—	5
Input sampling time	$t_{SPL}$	—	31	—	—	15	—
A/D conversion time	$t_{CONV}$	131	—	134	69	—	70

Note: Values in the table are numbers of states.

#### 15.4.4 External Trigger Input Timing

A/D conversion can be externally triggered. When the TRGE bit is set to 1 in ADCR and the 8-bit timer's ADTE bit is cleared to 0, external trigger input is enabled at the  $\overline{ADTRG}$  pin. A high-to-low transition at the  $\overline{ADTRG}$  pin sets the ADST bit to 1 in ADCSR, starting A/D conversion. Other operations, in both single and scan modes, are the same as if the ADST bit had been set to 1 by software. Figure 15.6 shows the timing.



**Figure 15.6 External Trigger Input Timing**

## 15.5 Interrupts

The A/D converter generates an interrupt (ADI) at the end of A/D conversion. The ADI interrupt request can be enabled or disabled by the ADIE bit in ADCSR. The ADI interrupt request can be designated as a DMAC activation source. In this case, an interrupt request is not sent to the CPU.

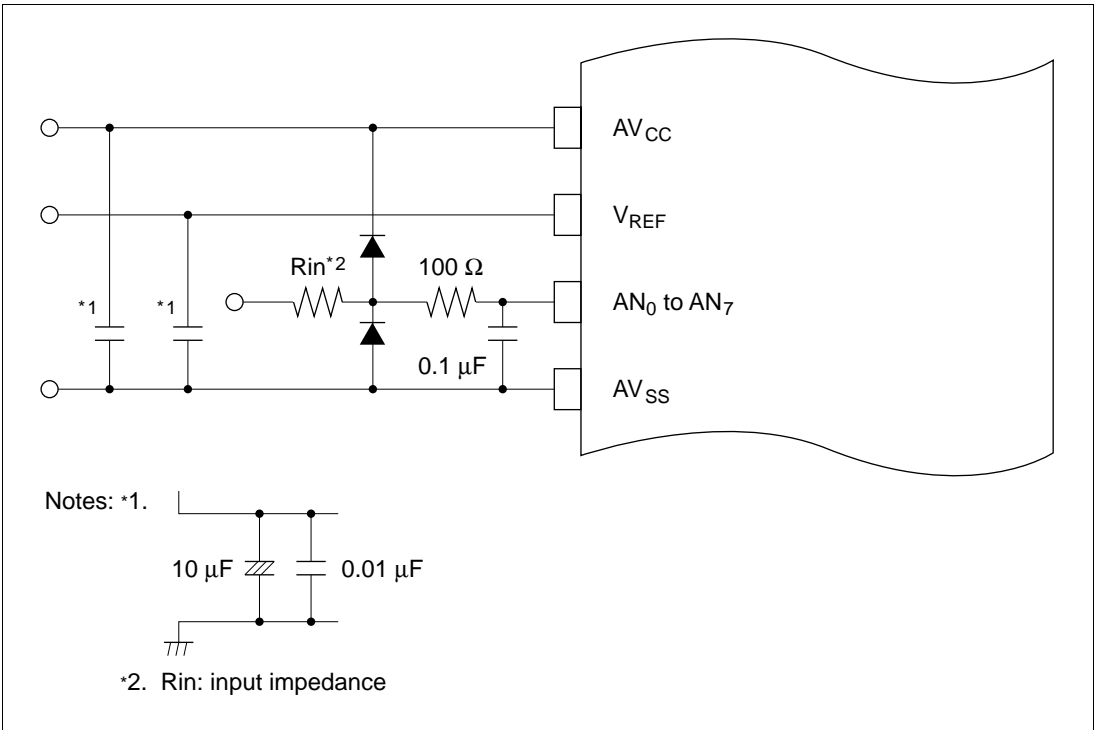
## 15.6 Usage Notes

When using the A/D converter, note the following points:

1. Analog Input Voltage Range: During A/D conversion, the voltages input to the analog input pins should be in the range  $AV_{SS} \leq AN_n \leq V_{REF}$ .
2. Relationships of  $AV_{CC}$  and  $AV_{SS}$  to  $V_{CC}$  and  $V_{SS}$ :  $AV_{CC}$ ,  $AV_{SS}$ ,  $V_{CC}$ , and  $V_{SS}$  should be related as follows:  $AV_{SS} = V_{SS}$ .  $AV_{CC}$  and  $AV_{SS}$  must not be left open, even if the A/D converter is not used.
3.  $V_{REF}$  Programming Range: The reference voltage input at the  $V_{REF}$  pin should be in the range  $V_{REF} \leq AV_{CC}$ .
4. Note on Board Design: In board layout, separate the digital circuits from the analog circuits as much as possible. Particularly avoid layouts in which the signal lines of digital circuits cross or closely approach the signal lines of analog circuits. Induction and other effects may cause the analog circuits to operate incorrectly, or may adversely affect the accuracy of A/D conversion.

The analog input signals ( $AN_0$  to  $AN_7$ ), analog reference voltage ( $V_{REF}$ ), and analog supply voltage ( $AV_{CC}$ ) must be separated from digital circuits by the analog ground ( $AV_{SS}$ ). The analog ground ( $AV_{SS}$ ) should be connected to a stable digital ground ( $V_{SS}$ ) at one point on the board.

5. Note on Noise: To prevent damage from surges and other abnormal voltages at the analog input pins ( $AN_0$  to  $AN_7$ ) and analog reference voltage pin ( $V_{REF}$ ), connect a protection circuit like the one in figure 15.7 between  $AV_{CC}$  and  $AV_{SS}$ . The bypass capacitors connected to  $AV_{CC}$  and  $V_{REF}$  and the filter capacitors connected to  $AN_0$  to  $AN_7$  must be connected to  $AV_{SS}$ . If filter capacitors like the ones in figure 15.7 are connected, the voltage values input to the analog input pins ( $AN_0$  to  $AN_7$ ) will be smoothed, which may give rise to error. Error can also occur if A/D conversion is frequently performed in scan mode so that the current that charges and discharges the capacitor in the sample-and-hold circuit of the A/D converter becomes greater than that input to the analog input pins via input impedance  $R_{in}$ . The circuit constants should therefore be selected carefully.

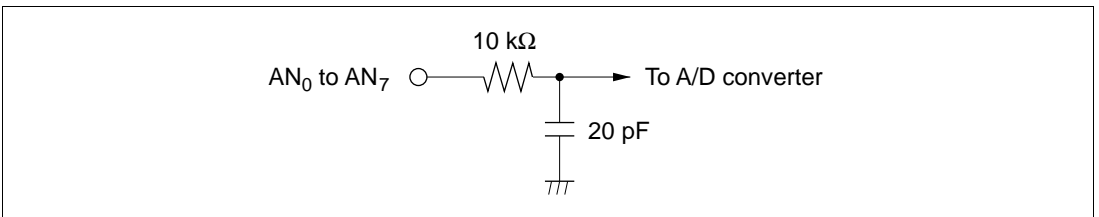


**Figure 15.7 Example of Analog Input Protection Circuit**

**Table 15.5 Analog Input Pin Ratings**

Item	min	max	Unit
Analog input capacitance	—	20	pF
Allowable signal-source impedance	—	10*	k

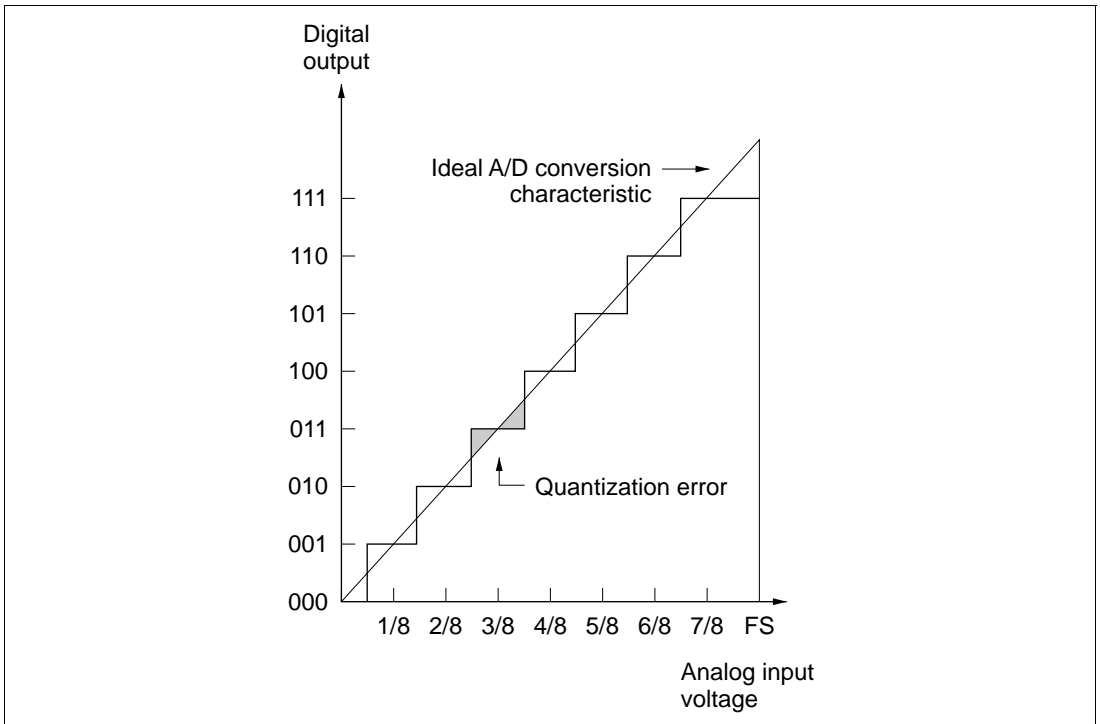
Note: \* When conversion time = 134 states,  $V_{CC} = 4.0\ \text{V}$  to  $5.5\ \text{V}$ , and  $\phi = 13\ \text{MHz}$ . For details see section 21, Electrical Characteristics.



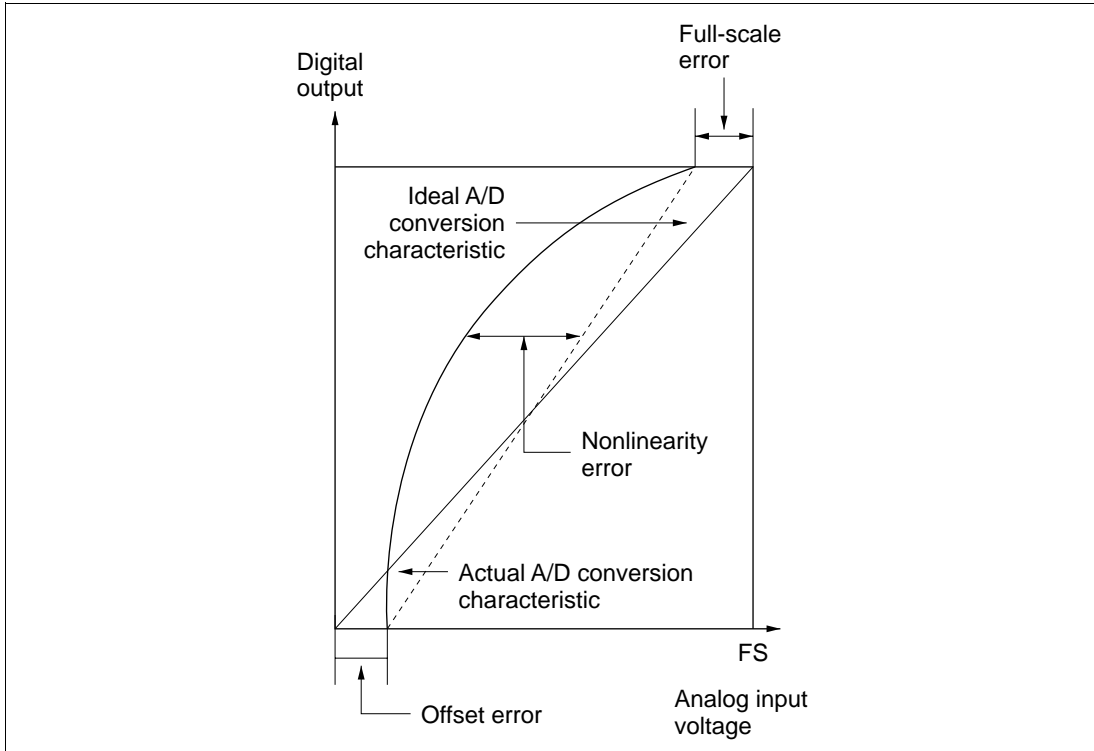
**Figure 15.8 Analog Input Pin Equivalent Circuit**

Note: Numeric values are approximate, except in table 15.5

6. A/D Conversion Accuracy Definitions: A/D conversion accuracy in the H8/3067 Series is defined as follows:
- Resolution: .....Digital output code length of A/D converter
  - Offset error: .....Deviation from ideal A/D conversion characteristic of analog input voltage required to raise digital output from minimum voltage value 0000000000 to 0000000001 (figure 15.10)
  - Full-scale error: .....Deviation from ideal A/D conversion characteristic of analog input voltage required to raise digital output from 111111110 to 111111111 (figure 15.10)
  - Quantization error: .....Intrinsic error of the A/D converter; 1/2 LSB (figure 15.9)
  - Nonlinearity error: .....Deviation from ideal A/D conversion characteristic in range from zero volts to full scale, exclusive of offset error, full-scale error, and quantization error.
  - Absolute accuracy: .....Deviation of digital value from analog input value, including offset error, full-scale error, quantization error, and nonlinearity error.



**Figure 15.9 A/D Converter Accuracy Definitions (1)**



**Figure 15.10 A/D Converter Accuracy Definitions (2)**

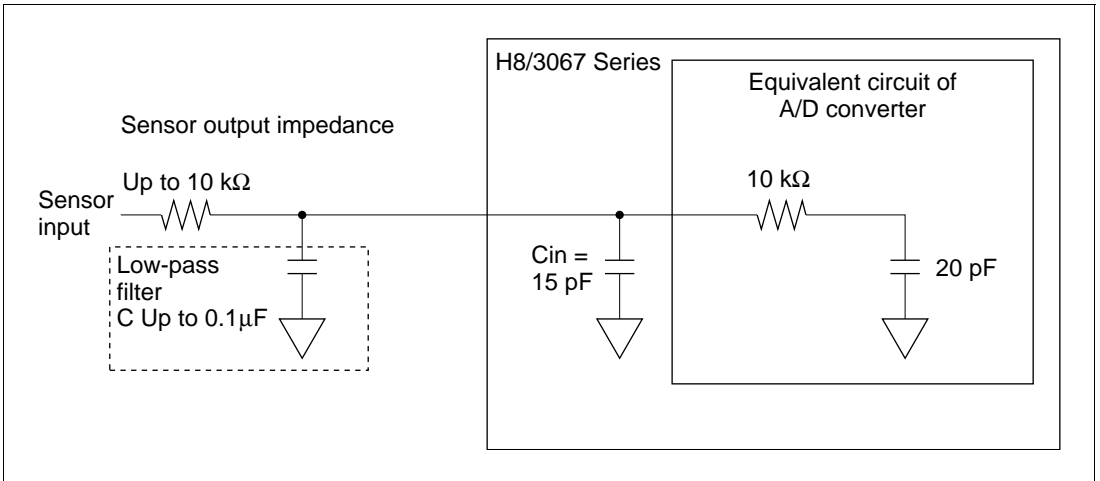
7. Allowable Signal-Source Impedance: The analog inputs of the H8/3067 Series are designed to assure accurate conversion of input signals with a signal-source impedance not exceeding 10 k. The reason for this rating is that it enables the input capacitor in the sample-and-hold circuit in the A/D converter to charge within the sampling time. If the sensor output impedance exceeds 10 k, charging may be inadequate and the accuracy of A/D conversion cannot be guaranteed.

If a large external capacitor is provided in single mode, then the internal 10-k input resistance becomes the only significant load on the input. In this case the impedance of the signal source is not a problem.

A large external capacitor, however, acts as a low-pass filter. This may make it impossible to track analog signals with high  $dv/dt$  (e.g. a variation of  $5 \text{ mV}/\mu\text{s}$ ) (figure 15.11). To convert high-speed analog signals or to use scan mode, insert a low-impedance buffer.

8. Effect on Absolute Accuracy: Attaching an external capacitor creates a coupling with ground, so if there is noise on the ground line, it may degrade absolute accuracy. The capacitor must be connected to an electrically stable ground, such as  $AV_{SS}$ .

If a filter circuit is used, be careful of interference with digital signals on the same board, and make sure the circuit does not act as an antenna.



**Figure 15.11 Analog Input Circuit (Example)**





# Section 16 D/A Converter

## 16.1 Overview

The H8/3067 Series includes a D/A converter with two channels.

### 16.1.1 Features

D/A converter features are listed below.

- Eight-bit resolution
- Two output channels
- Conversion time: maximum 10  $\mu\text{s}$  (with 20-pF capacitive load)
- Output voltage: 0 V to  $V_{\text{REF}}$
- D/A outputs can be sustained in software standby mode

### 16.1.2 Block Diagram

Figure 16.1 shows a block diagram of the D/A converter.

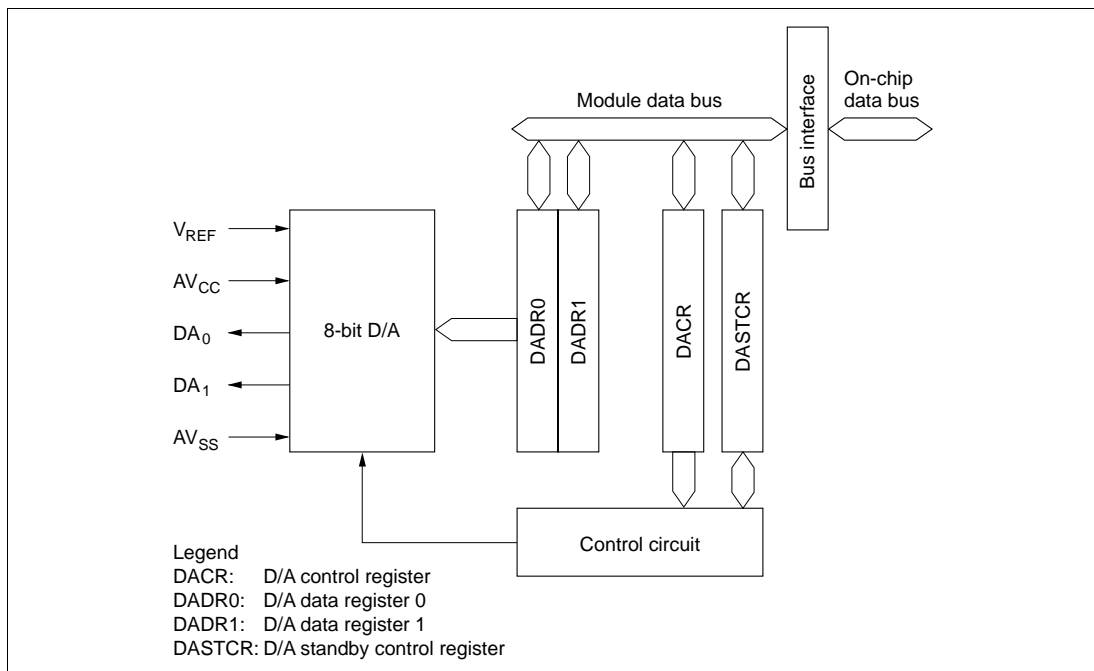


Figure 16.1 D/A Converter Block Diagram

### 16.1.3 Input/Output Pins

Table 16.1 summarizes the D/A converter's input and output pins.

**Table 16.1 D/A Converter Pins**

Pin Name	Abbreviation	I/O	Function
Analog power supply pin	$AV_{CC}$	Input	Analog power supply and reference voltage
Analog ground pin	$AV_{SS}$	Input	Analog ground and reference voltage
Analog output pin 0	$DA_0$	Output	Analog output, channel 0
Analog output pin 1	$DA_1$	Output	Analog output, channel 1
Reference voltage input pin	$V_{REF}$	Input	Analog reference voltage

### 16.1.4 Register Configuration

Table 16.2 summarizes the D/A converter's registers.

**Table 16.2 D/A Converter Registers**

Address*	Name	Abbreviation	R/W	Initial Value
H'FFF9C	D/A data register 0	DADR0	R/W	H'00
H'FFF9D	D/A data register 1	DADR1	R/W	H'00
H'FFF9E	D/A control register	DACR	R/W	H'1F
H'EE01A	D/A standby control register	DASTCR	R/W	H'FE

Note: \* Lower 20 bits of the address in advanced mode.

## 16.2 Register Descriptions

### 16.2.1 D/A Data Registers 0 and 1 (DADR0/1)

Bit	7	6	5	4	3	2	1	0
Initial value	0	0	0	0	0	0	0	0
Read/Write	R/W	R/W	R/W	R/W	R/W	R/W	R/W	R/W

The D/A data registers (DADR0 and DADR1) are 8-bit readable/writable registers that store the data to be converted. When analog output is enabled, the D/A data register values are constantly converted and output at the analog output pins.

The D/A data registers are initialized to H'00 by a reset and in standby mode.

When the DASTE bit is set to 1 in the D/A standby control register (DASTCR), the D/A registers are not initialized in software standby mode.

### 16.2.2 D/A Control Register (DACR)

Bit	7	6	5	4	3	2	1	0
	DAOE1	DAOE0	DAE	—	—	—	—	—
Initial value	0	0	0	1	1	1	1	1
Read/Write	R/W	R/W	R/W	—	—	—	—	—

**D/A enable**  
 Controls D/A conversion

**D/A output enable 0**  
 Controls D/A conversion and analog output

**D/A output enable 1**  
 Controls D/A conversion and analog output

DACR is an 8-bit readable/writable register that controls the operation of the D/A converter. DACR is initialized to H'1F by a reset and in standby mode.

When the DASTE bit is set to 1 in DASTCR, the DACR is not initialized in software standby mode.

**Bit 7—D/A Output Enable 1 (DAOE1):** Controls D/A conversion and analog output.

**Bit 7**

**DAOE1      Description**

0	DA <sub>1</sub> analog output is disabled
1	Channel-1 D/A conversion and DA <sub>1</sub> analog output are enabled

**Bit 6—D/A Output Enable 0 (DAOE0):** Controls D/A conversion and analog output.

**Bit 6**

**DAOE0      Description**

0	DA <sub>0</sub> analog output is disabled
1	Channel-0 D/A conversion and DA <sub>0</sub> analog output are enabled

**Bit 5—D/A Enable (DAE):** Controls D/A conversion, together with bits DAOE0 and DAOE1. When the DAE bit is cleared to 0, analog conversion is controlled independently in channels 0 and 1. When the DAE bit is set to 1, analog conversion is controlled together in channels 0 and 1. Output of the conversion results is always controlled independently by DAOE0 and DAOE1.

Bit 7 DAOE1	Bit 6 DAOE0	Bit 5 DAE	Description
0	0	—	D/A conversion is disabled in channels 0 and 1
		1	D/A conversion is enabled in channel 0 D/A conversion is disabled in channel 1
	1	1	D/A conversion is enabled in channels 0 and 1
1	0	0	D/A conversion is disabled in channel 0 D/A conversion is enabled in channel 1
		1	D/A conversion is enabled in channels 0 and 1
	1	—	D/A conversion is enabled in channels 0 and 1

When the DAE bit is set to 1, even if bits DAOE0 and DAOE1 in DACR and the ADST bit in ADCSR are cleared to 0, the same current is drawn from the analog power supply as during A/D and D/A conversion.

**Bits 4 to 0—Reserved:** These bits cannot be modified and are always read as 1.

### 16.2.3 D/A Standby Control Register (DASTCR)

DASTCR is an 8-bit readable/writable register that enables or disables D/A output in software standby mode.

Bit	7	6	5	4	3	2	1	0
	—	—	—	—	—	—	—	DASTE
Initial value	1	1	1	1	1	1	1	0
Read/Write	—	—	—	—	—	—	—	R/W

Reserved bits

D/A standby enable  
Enables or disables D/A output  
in software standby mode

DASTCR is initialized to H'FE by a reset and in hardware standby mode. It is not initialized in software standby mode.

**Bits 7 to 1—Reserved:** These bits cannot be modified and are always read as 1.

**Bit 0—D/A Standby Enable (DASTE):** Enables or disables D/A output in software standby mode.

#### Bit 0

#### DASTE

#### Description

0	D/A output is disabled in software standby mode	(Initial value)
1	D/A output is enabled in software standby mode	

## 16.3 Operation

The D/A converter has two built-in D/A conversion circuits that can perform conversion independently.

D/A conversion is performed constantly while enabled in DACR. If the DADR0 or DADR1 value is modified, conversion of the new data begins immediately. The conversion results are output when bits DAOE0 and DAOE1 are set to 1.

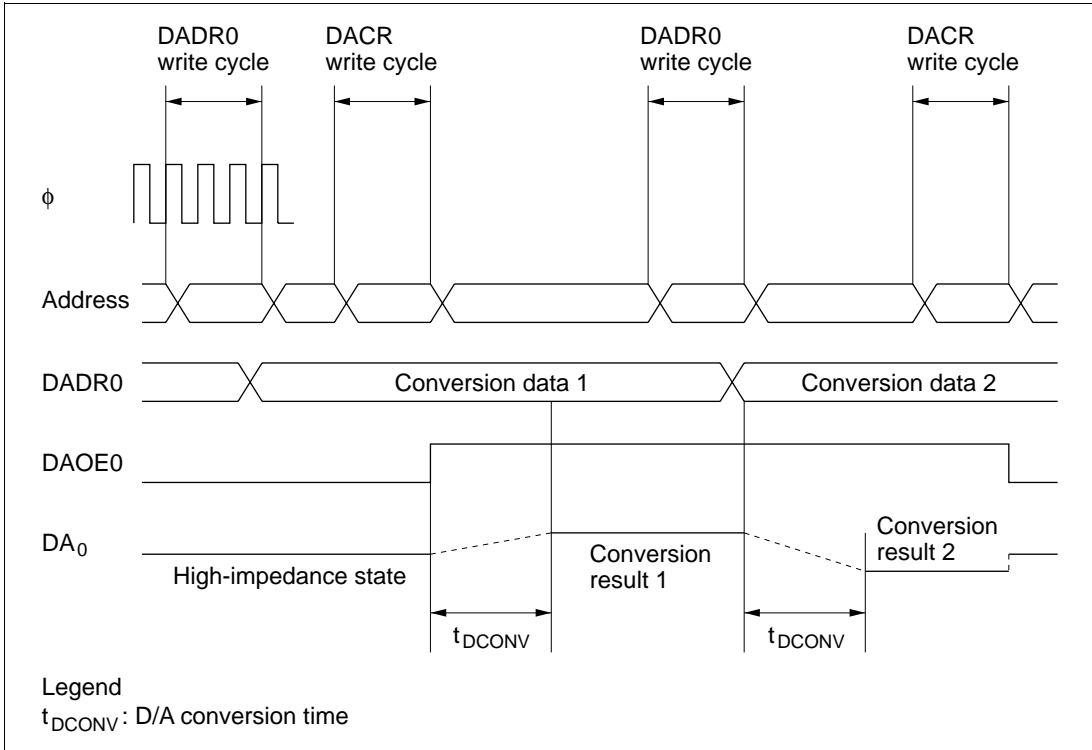
An example of D/A conversion on channel 0 is given next. Timing is indicated in figure 16.2.

1. Data to be converted is written in DADR0.
2. Bit DAOE0 is set to 1 in DACR. D/A conversion starts and DA0 becomes an output pin. The converted result is output after the conversion time.

The output value is  $\frac{\text{DADR contents}}{256} \times V_{\text{REF}}$

Output of this conversion result continues until the value in DADR0 is modified or the DAOE0 bit is cleared to 0.

3. If the DADR0 value is modified, conversion starts immediately, and the result is output after the conversion time.
4. When the DAOE0 bit is cleared to 0, DA0 becomes an input pin.



**Figure 16.2 Example of D/A Converter Operation**

## 16.4 D/A Output Control

In the H8/3067 Series, D/A converter output can be enabled or disabled in software standby mode.

When the DASTE bit is set to 1 in DASTCR, D/A converter output is enabled in software standby mode. The D/A converter registers retain the values they held prior to the transition to software standby mode.

When D/A output is enabled in software standby mode, the reference supply current is the same as during normal operation.





# Section 17 RAM

## 17.1 Overview

The H8/3067 and H8/3066 have 4 kbytes of high-speed static RAM on-chip. The H8/3065 has 2 kbytes. The RAM is connected to the CPU by a 16-bit data bus. The CPU accesses both byte data and word data in two states, making the RAM useful for rapid data transfer.

The on-chip RAM of the H8/3067 and H8/3066 is assigned to addresses H'FEF20 to H'FFF1F in modes 1, 2, and 7, and to addresses H'FFE20 to H'FFFF1F in modes 3, 4, and 5, and to addresses H'EF20 to H'FF1F in mode 6. The on-chip RAM of the H8/3065 are assigned to addresses H'FF720 to H'FFF1F in modes 1, 2, and 7, and to addresses H'FFF720 to H'FFFF1F in modes 3, 4, and 5, and to addresses H'F720 to H'FF1F in mode 6. The RAM enable bit (RAME) in the system control register (SYSCR) can enable or disable the on-chip RAM.

### 17.1.1 Block Diagram

Figure 17.1 shows a block diagram of the on-chip RAM.

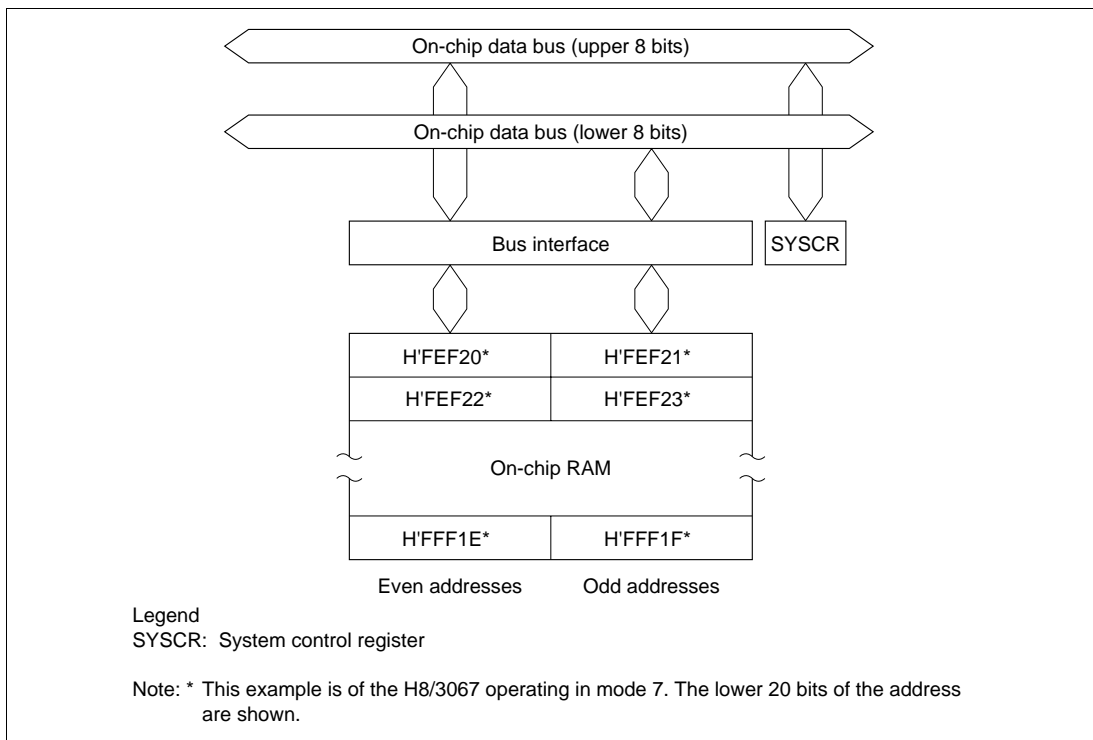


Figure 17.1 RAM Block Diagram

## 17.1.2 Register Configuration

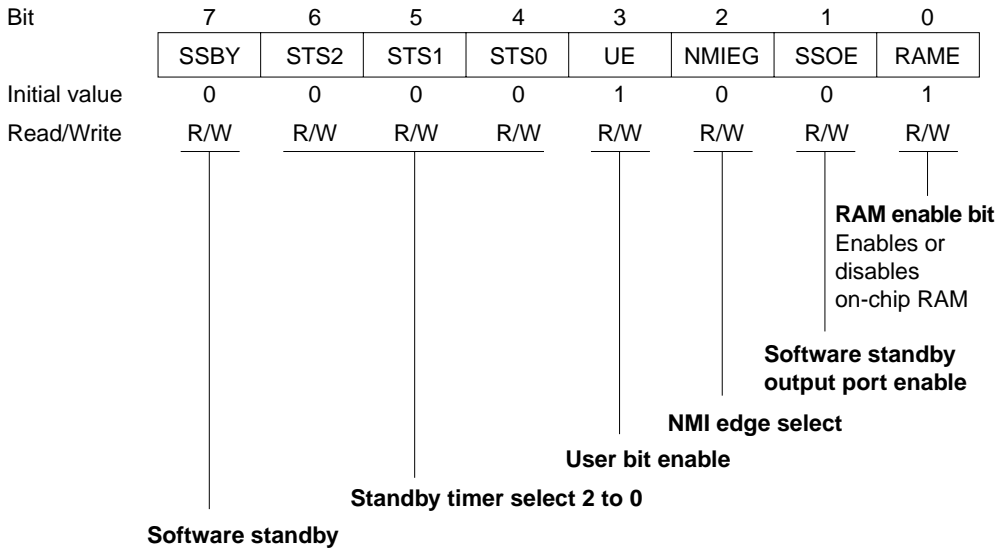
The on-chip RAM is controlled by SYSCR. Table 17.1 gives the address and initial value of SYSCR.

**Table 17.1 System Control Register**

<b>Address*</b>	<b>Name</b>	<b>Abbreviation</b>	<b>R/W</b>	<b>Initial Value</b>
H'EE012	System control register	SYSCR	R/W	H'09

Note: \* Lower 20 bits of the address in advanced mode.

## 17.2 System Control Register (SYSCR)



One function of SYSCR is to enable or disable access to the on-chip RAM. The on-chip RAM is enabled or disabled by the RAME bit in SYSCR. For details about the other bits, see section 3.3, System Control Register (SYSCR).

**Bit 0—RAM Enable (RAME):** Enables or disables the on-chip RAM. The RAME bit is initialized at the rising edge of the input at the  $\overline{\text{RES}}$  pin. It is not initialized in software standby mode.

### Bit 0

#### RAME

#### Description

0	On-chip RAM is disabled
1	On-chip RAM is enabled (Initial value)

## 17.3 Operation

When the RAME bit is set to 1, the on-chip RAM is enabled. Accesses to addresses H'FEF20 to H'FFF1F in the H8/3067 and H8/3066 in modes 1, 2, and 7, and to addresses H'FEF20 to H'FFF1F in the H8/3067 and H8/3066 in modes 3, 4, and 5, and to addresses H'EF20 to H'FF1F in mode 6, are directed to the on-chip RAM. In the H8/3065, accesses to addresses H'FF720 to H'FFF1F in modes 1, 2, and 7, to addresses H'FFF720 to H'FFF1F in modes 3, 4, and 5, and to addresses H'F720 to H'FF1F in mode 6, are directed to the on-chip RAM. In modes 1 to 5 (expanded modes), when the RAME bit is cleared to 0, the off-chip address space is accessed. In mode 6, 7 (single-chip mode), when the RAME bit is cleared to 0, the on-chip RAM is not accessed: read access always results in H'FF data, and write access is ignored.

Since the on-chip RAM is connected to the CPU by an internal 16-bit data bus, it can be written and read by word access. It can also be written and read by byte access. Byte data is accessed in two states using the upper 8 bits of the data bus. Word data starting at an even address is accessed in two states using all 16 bits of the data bus.

## 18.1 Overview

The H8/3067 has 128 kbytes of on-chip ROM (flash memory or mask ROM), the H8/3066 has 96 kbytes, and H8/3065 has 64 kbytes. The ROM is connected to the CPU by a 16-bit data bus. The CPU accesses both byte and word data in two states, enabling rapid data transfer.

The mode pins ( $MD_2$  to  $MD_0$ ) can be set to enable or disable the on-chip ROM. See table 18.1.

The on-chip flash memory product (H8/3067F-ZTAT) can be erased and programmed on-board as well as with a general-purpose PROM programmer.

**Table 18.1 Operating Mode and ROM**

Mode	Mode Pins			On-Chip ROM
	$MD_2$	$MD_1$	$MD_0$	
Mode 1 (1-Mbyte expanded mode with on-chip ROM disabled)	0	0	1	Disabled (external address area)
Mode 2 (1-Mbyte expanded mode with on-chip ROM disabled)	0	1	0	
Mode 3 (16-Mbyte expanded mode with on-chip ROM disabled)	0	1	1	
Mode 4 (16-Mbyte expanded mode with on-chip ROM disabled)	1	0	0	Enabled
Mode 5 (16-Mbyte expanded mode with on-chip ROM enabled)	1	0	1	
Mode 6 (single-chip normal mode)	1	1	0	
Mode 7 (single-chip advanced mode)	1	1	1	

## 18.2 Overview of Flash Memory

### 18.2.1 Features

The features of the flash memory are summarized below.

- Four flash memory operating modes
  - Program mode
  - Erase mode
  - Program-verify mode
  - Erase-verify mode
- Programming/erase methods

The flash memory is programmed 32 bytes at a time. Erasing is performed by block erase. The block to be erased can be specified by setting the corresponding bit. There are block areas of  $32\text{KB} \times 3$  blocks,  $28\text{KB} \times 1$  block, and  $1\text{KB} \times 4$  blocks.
- Programming/erase times

The flash memory programming time is 10 ms (typ.) for simultaneous 32-byte programming, equivalent to 300  $\mu\text{s}$  (typ.) per byte, and the erase time is 100 ms (typ.) per block.
- Reprogramming capability

The flash memory can be reprogrammed up to 100 times.
- On-board programming modes

There are two modes in which flash memory can be programmed/erased/verified on-board:

  - Boot mode
  - User program mode
- Automatic bit rate adjustment

With data transfer in boot mode, the H8/3067's bit rate can be automatically adjusted to match the transfer bit rate of the host (9600 bps and 4800 bps).
- Flash memory emulation by RAM

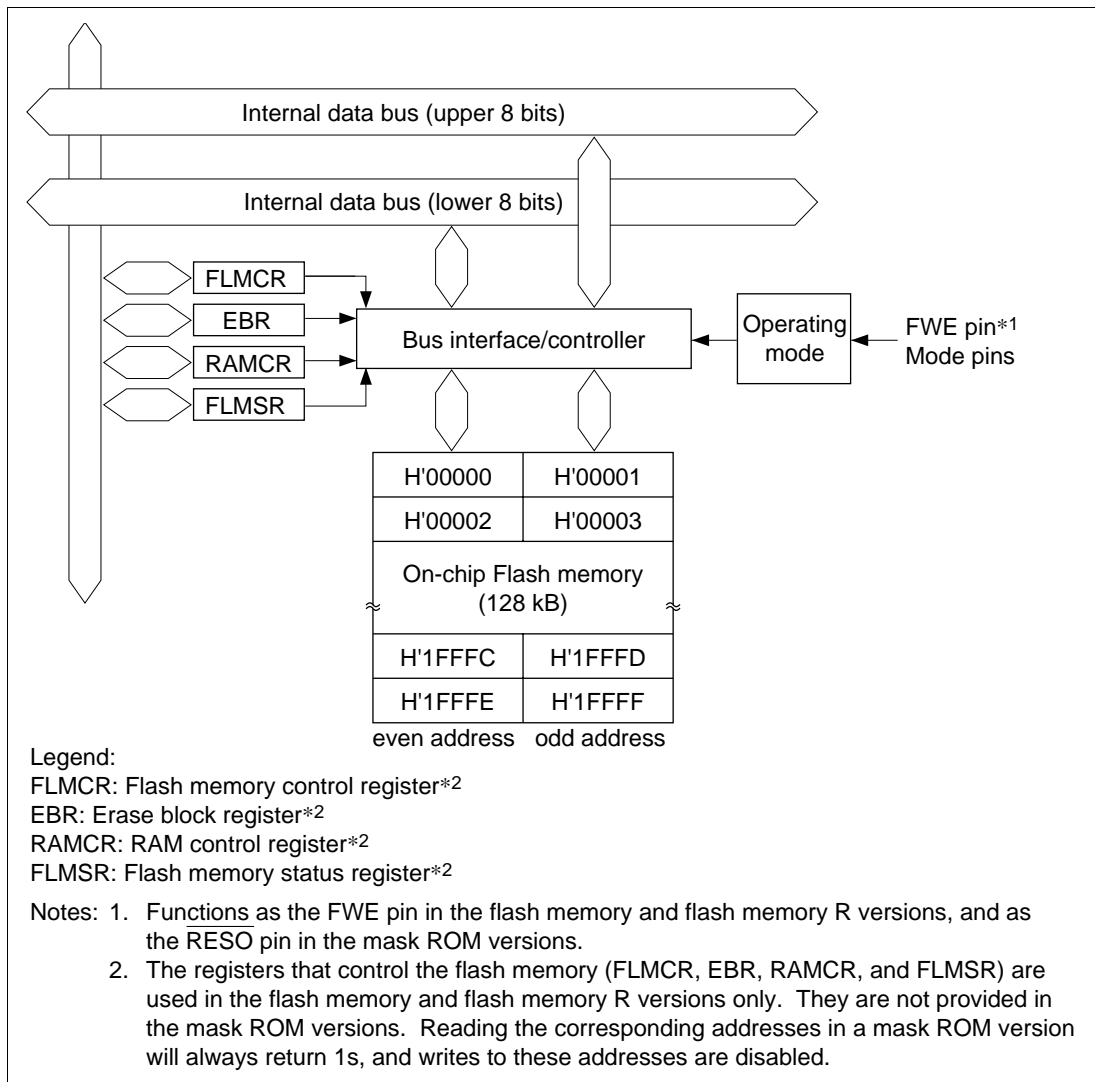
Part of the RAM area can be overlapped onto flash memory, to emulate flash memory updates in real time.
- PROM mode

Flash memory can be programmed/erased in PROM mode, using a PROM programmer, as well as in on-board programming mode.
- Protect modes

There are three protect modes, hardware, software, and error protect, which allow protected status to be designated for flash memory program/erase/verify operations.

## 18.2.2 Block Diagram

Figure 18.1 shows a block diagram of the flash memory.



**Figure 18.1 Block Diagram of Flash Memory**

### 18.2.3 Pin Configuration

The flash memory is controlled by means of the pins shown in table 18.2.

**Table 18.2 Flash Memory Pins**

Pin Name	Abbreviation	I/O	Function
Reset	$\overline{\text{RES}}$	Input	Reset
Flash write enable	FWE*	Input	Flash program/erase protection by hardware
Mode 2	MD <sub>2</sub>	Input	Sets this LSI operating mode
Mode 1	MD <sub>1</sub>	Input	Sets this LSI operating mode
Mode 0	MD <sub>0</sub>	Input	Sets this LSI operating mode
Transmit data	TxD <sub>1</sub>	Output	Serial transmit data output
Receive data	RxD <sub>1</sub>	Input	Serial receive data input

Note: The transmit data and receive data pins are used in boot mode.

\* In the mask ROM versions, the FWE pin functions as the  $\overline{\text{RES0}}$  pin.

### 18.2.4 Register Configuration

The registers used to control the on-chip flash memory when enabled are shown in table 18.3.

**Table 18.3 Flash Memory Registers**

Register Name	Abbreviation	R/W	Initial Value	Address* <sup>1</sup>
Flash memory control register	FLMCR	R/W	H'00* <sup>2</sup>	H'EE030
Erase block register	EBR	R/W	H'00	H'EE032
RAM control register	RAMCR	R/W	H'F1	H'EE077
Flash memory status register	FLMSR	R	H'7F	H'EE07D

Notes: 1. Lower 20 bits of address in advanced mode.

2. When a high level is input to the FWE pin, the initial value is H'80.

The registers in table 18.3 are used in the flash memory and flash memory R versions only. Reading the corresponding addresses in a mask ROM version will always return 1s, and writes to these addresses are disabled.



## 18.3 Register Descriptions

### 18.3.1 Flash Memory Control Register (FLMCR)

FLMCR is an 8-bit register used for flash memory operating mode control. Program-verify mode or erase-verify mode is entered by setting SWE to 1 when FWE = 1. Program mode is entered by setting SWE to 1 when FWE = 1, then setting the PSU bit, and finally setting the P bit. Erase mode is entered by setting SWE to 1 when FWE = 1, then setting the ESU bit, and finally setting the E bit. FLMCR is initialized by a reset, and in hardware standby mode and software standby mode. Its initial value is H'80 when a high level is input to the FWE pin, and H'00 when a low level is input. In mode 6 the FWE pin must be fixed low, as flash memory on-board programming is not supported. Therefore, bits in this register cannot be set to 1 in mode 6. When on-chip flash memory is disabled, a read will return H'00, and writes are invalid. When setting bits 6 to 0 in this register to 1, each bit should be set individually.

Writes to the ESU, PSU, EV and PV bits in FLMCR are enabled only when FWE = 1 and SWE = 1; writes to the E bit only when FWE = 1, SWE = 1, and ESU = 1; and writes to the P bit only when FWE = 1, SWE = 1, and PSU = 1.

Bit		7	6	5	4	3	2	1	0
		FWE	SWE	ESU	PSU	EV	PV	E	P
Modes 1 to 4, and 6	Initial value	0	0	0	0	0	0	0	0
	R/W	R	R	R	R	R	R	R	R
Modes 5 and 7	Initial value	1/0	0	0	0	0	0	0	0
	R/W	R	R/W	R/W	R/W	R/W	R/W	R/W	R/W

**Program mode**  
Designates transition to or exit from program mode

**Erase mode**  
Designates transition to or exit from erase mode

**Program-verify mode**  
Designates transition to or exit from program-verify mode

**Erase-verify mode**  
Designates transition to or exit from erase-verify mode

**Program setup**  
Prepares for a transition to program mode.

**Erase setup**  
Prepares for a transition to erase mode.

**Software write enable bit**  
Enables or disables the flash memory.

**Flash write enable bit**  
Sets hardware protection against flash memory programming/erasing.

**Bit 7—Flash Write Enable Bit (FWE):** Sets hardware protection against flash memory programming/erasing. When using this bit, refer to section 18.9, Notes on Flash Memory Programming/Erasing.

**Bit 7:**

**FWE Description**

0	When a low level is input to the FWE pin (hardware-protected state)
1	When a high level is input to the FWE pin

**Bit 6—Software Write Enable Bit (SWE)\*1,\*2:** This bit enables/disables flash memory programming/erasing. This bit should be set before setting FLMCR bits 5 to 0, and EBR bits 7 to 0. Do not set the ESU, PSU, EV, PV, E, or P bits at the same time.

**Bit 6:**

<b>SWE</b>	<b>Description</b>	
0	Program/erase disabled	(Initial value)
1	Program/erase enabled [Setting condition] When FWE = 1	

**Bit 5—Erase Setup Bit (ESU) \*1:** Prepares for a transition to erase mode. Do not set the SWE, PSU, EV, PV, E, or P bit at the same time.

**Bit 5:**

<b>ESU</b>	<b>Description</b>	
0	Erase setup cleared	(Initial value)
1	Erase setup [Setting condition] When FWE = 1, and SWE = 1	

**Bit 4—Program Setup Bit (PSU) \*1:** Prepares for a transition to program mode. Do not set the SWE, ESU, EV, PV, E, or P bit at the same time.

**Bit 4:**

<b>PSU</b>	<b>Description</b>	
0	Program setup cleared	(Initial value)
1	Program setup [Setting condition] When FWE = 1, and SWE = 1	

**Bit 3—Erase-Verify (EV) \*1:** Selects erase-verify mode transition or clearing. Do not set the SWE, ESU, PSU, PV, E, or P bit at the same time.

**Bit 3:**

<b>EV</b>	<b>Description</b>	
0	Erase-verify mode cleared	(Initial value)
1	Transition to erase-verify mode [Setting condition] When FWE = 1, and SWE = 1	

**Bit 2—Program-Verify (PV)\*1:** Selects program-verify mode transition or clearing. Do not set the SWE, ESU, PSU, EV, E, or P bit at the same time.

**Bit 2:**

PV	Description	
0	Program-verify mode cleared	(Initial value)
1	Transition to program-verify mode [Setting condition] When FWE = 1, and SWE = 1	

**Bit 1—Erase (E) \*<sup>1</sup>, \*<sup>3</sup>:** Selects erase mode transition or clearing. Do not set the SWE, ESU, PSU, EV, PV, or P bit at the same time.

**Bit 1:**

E	Description	
0	Erase mode cleared	(Initial value)
1	Transition to erase mode [Setting condition] When FWE = 1, SWE = 1, and ESU = 1	

**Bit 0—Program (P) \*<sup>1</sup>, \*<sup>3</sup>:** Selects program mode transition or clearing. Do not set the SWE, ESU, PSU, EV, PV, or E bit at the same time.

**Bit 0:**

P	Description	
0	Program mode cleared	(Initial value)
1	Transition to program mode [Setting condition] When FWE = 1, SWE = 1, and PSU = 1	

Notes: 1. Do not set two or more bits at the same time.

Do not turn off  $V_{CC}$  when a bit is set.

2. Do not set/clear the SWE bit simultaneously with other bits (ESU, PSU, EV, PV, E, P).
3. Set the P and E bits according to the program and erase algorithms shown in section 18.5, Programming and Erasing Flash Memory.

For the usage precautions, see section 18.9, Notes on Flash Memory Programming/Erasing.

### 18.3.2 Erase Block Register (EBR)

EBR is an 8-bit register that designates the flash memory block for erasure. EBR is initialized to H'00 by a reset, in hardware standby mode, or software standby mode, when a high level is not input to the FWE terminal, or when the FLMCR SWE bit is 0 when a high level is applied to the FWE terminal. When a bit is set in EBR, the corresponding block can be erased. Other blocks are erase - protected. The blocks are erased block by block. Therefore, set only one bit in EBR; do not set bits in EBR to erase two or more blocks at the same time.

Each bit in EBR cannot be set until the SWE bit in FLMCR is set. The flash memory block configuration is shown in table 18.4. To erase all the blocks, erase each block sequentially.

The H8/3067 Series does not support the on-board programming mode in mode 6, so bits in this register cannot be set to 1 in mode 6.

Bit		7	6	5	4	3	2	1	0
		EB7	EB6	EB5	EB4	EB3	EB2	EB1	EB0
Modes 1 to 4, and 6	Initial value	0	0	0	0	0	0	0	0
	R/W	R	R	R	R	R	R	R	R
Modes 5 and 7	Initial value	0	0	0	0	0	0	0	0
	R/W	R/W	R/W	R/W	R/W	R/W	R/W	R/W	R/W

**Bits 7 to 0—Block 7 to 0 (EB7 to EB0):** These bits select blocks (EB7 to EB0) to be erased.

#### Bits 7 to 0:

#### EB7 to EB0 Description

0	Block EB7 to EB0 is not selected.	(Initial value)
1	Block EB7 to EB0 is selected.	

Note: Set each bit of EBR to H'00 except when erasing.

**Table 18.4 Flash Memory Erase Blocks**

Block (Size)	Address
EB0 (1 kB)	H'000000 to H'0003FF
EB1 (1 kB)	H'000400 to H'0007FF
EB2 (1 kB)	H'000800 to H'000BFF
EB3 (1 kB)	H'000C00 to H'000FFF
EB4 (28 kB)	H'001000 to H'007FFF
EB5 (32 kB)	H'008000 to H'00FFFF
EB6 (32 kB)	H'010000 to H'017FFF
EB7 (32 kB)	H'018000 to H'01FFFF

### 18.3.3 RAM Control Register (RAMCR)

RAMCR selects the RAM area used when emulating real-time reprogramming of the flash memory.

Bit		7	6	5	4	3	2	1	0
		—	—	—	—	RAMS	RAM2	RAM1	—
Modes 1 to 4	Initial value	1	1	1	1	0	0	0	1
	R/W	—	—	—	—	R	R	R	—
Modes 5 to 7	Initial value	1	1	1	1	0	0	0	1
	R/W	—	—	—	—	R/W*	R/W*	R/W*	—

Reserved bit

**RAM2/1**  
 This bit is used with bit 3 to set the RAM area.

**RAM select**  
 This bit is used with bits 2 and 1 to set the RAM area.

Reserved bits

Note: Cannot be set to 1 in mode 6.

**Bits 7 to 4—Reserved:** These bits cannot be modified and are always read as 1.

**Bit 3—RAM Select (RAMS):** Is used with bits 2 to 1 to reassign an area to RAM (see table 18.5). The initial setting for this bit is 0 in Modes 5, 6, and 7 (internal flash memory enabled) and programming is enabled.\* In modes other than 5 to 7, 0 is always read and writing is disabled. It is initialized by a reset and in hardware standby mode. It is not initialized in software standby mode.

When bit 3 is set, all flash-memory blocks are protected from programming and erasing.

**Bits 2 to 1—RAM2 to RAM1:** These bits are used with bit 3 to reassign an area to RAM (see table 18.5). The initial setting for this bit is 0 in Modes 5, 6, and 7 (internal flash memory enabled) and programming is enabled.\* In modes other than 5 to 7, 0 is always read and writing is disabled. They are initialized by a reset and in hardware standby mode. They are not initialized in software standby mode.

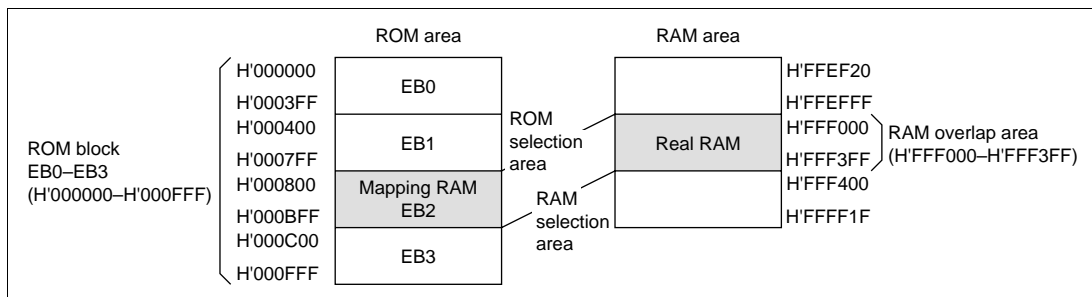
**Bit 0—Reserved:** This bit cannot be modified and is always read as 1.

Note: \* Flash memory emulation by RAM is not supported for Mode 6 (single chip normal mode), so programming is possible, but do not set 1.

When performing flash memory emulation by RAM, the RAME bit in SYSCR must be set to 1.

**Table 18.5 RAM Area Reassignment**

RAM Area	Bit 3	Bit 2	Bit 1	RAM Emulation State
	RAMS	RAM2	RAM1	
H'FFF000 to H'FFF3FF	0	0/1	0/1	No emulation
H'000000 to H'0003FF	1	0	0	Mapping RAM
H'000400 to H'0007FF	1	0	1	
H'000800 to H'000BFF	1	1	0	
H'000C00 to H'000FFF	1	1	1	



**Figure 18.2 Example of Overlap ROM Area and RAM Area**

### 18.3.4 Flash Memory Status Register

The flash memory status register (FLMSR) detects flash memory errors.

Bit	7	6	5	4	3	2	1	0
	FLER	—	—	—	—	—	—	—
Initial value	0	1	1	1	1	1	1	1
R/W	R	—	—	—	—	—	—	—

Reserved bits

**Flash memory error**

Status flag indicating that an error was detected during programming or erasing



**Bit 7—Flash Memory Error (FLER):** Indicates that an error occurred while flash memory was being programmed or erased. When bit 7 is set, flash memory is placed in an error-protect mode.

**Bit 7**

<b>FLER</b>	<b>Description</b>
0	Flash memory program/erase protection (error protection <sup>*1</sup> ) is disabled (Initial value) [Clearing conditions] WDT reset, reset by $\overline{\text{RES}}$ pin, or hardware standby mode
1	An error has occurred during flash memory programming/erasing Flash memory program/erase protection (error protection <sup>*1</sup> ) is enabled [Setting conditions] <ol style="list-style-type: none"><li>Flash memory was read<sup>*2</sup> while being programmed or erased (including vector or instruction fetch, but not including reading of a RAM area overlapped onto flash memory).</li><li>A hardware exception-handling sequence (other than a reset, invalid instruction, trap instruction, or zero-divide exception) was executed just before programming or erasing. <sup>*3</sup></li><li>The SLEEP instruction (including software standby mode) was executed during programming or erasing.</li></ol>

- Notes: 1. For details, see section 18.6.3, Error Protection.  
2. The read data has undetermined values.  
3. Before stack and vector read by exception handling.

**Bits 6 to 0—Reserved:** These bits cannot be modified and are always read as 1.

## 18.4 On-Board Programming Modes

When pins are set to on-board programming mode, program/erase/verify operations can be performed on the on-chip flash memory. There are two on-board programming modes: boot mode and user program mode. The pin settings for transition to each of these modes are shown in table 18.6. In H8/3067F mode 6 (on-chip ROM enabled), the boot mode and user program mode cannot be used. For the notes on FWE pin set/reset, see section 18.9 Notes on Flash Memory Programming/Erasing.

**Table 18.6 Setting On-Board Programming Modes**

Mode		FWE	MD <sub>2</sub>	MD <sub>1</sub>	MD <sub>0</sub>	Notes
Boot mode	mode 5	1* <sup>1</sup>	0* <sup>2</sup>	0	0	0 : V <sub>IL</sub>
	mode 7		0* <sup>2</sup>	1	0	1 : V <sub>IH</sub>
User program mode	mode 5		1	0	1	
	mode 7		1	1	1	

Notes: 1. For the High level input timing, see items (6) and (7) of Notes on Using the Boot Mode.  
 2. In the boot mode, the MD<sub>2</sub> setting becomes inverted input.

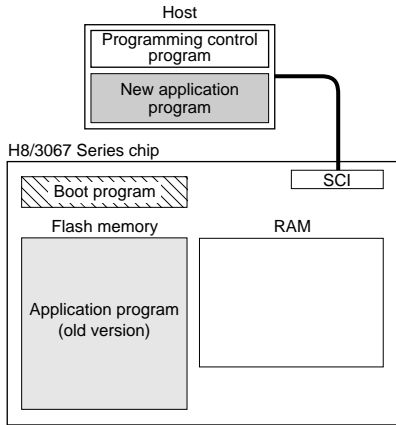
In the boot mode in the H8/3067 F-ZTAT™, the levels of the mode pins (MD<sub>2</sub> to MD<sub>0</sub>) are reflected in mode select bits 2 to 0 (MDS2 to MDS0) in the mode control register (MDCR). Note that this specification differs from that of the H8/3039F Series.

# On-Board Programming Modes

- Boot mode

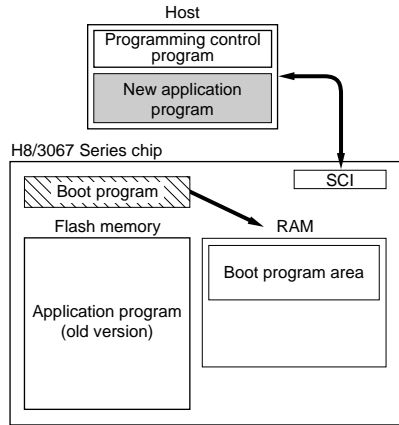
1. Initial state

The flash memory is in the erased state when the device is shipped. The description here applies to the case where the old program version or data is being rewritten. The user should prepare the programming control program and new application program beforehand in the host.



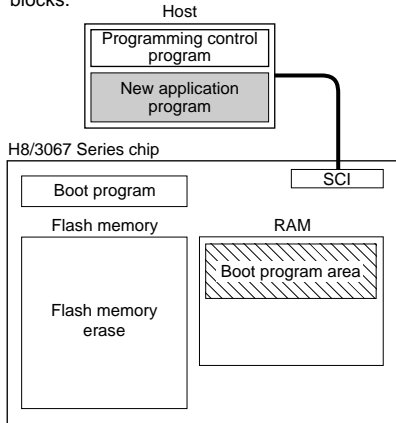
2. Programming control program transfer

When boot mode is entered, the boot program in the H8/3067 Series chip (originally incorporated in the chip) is started, an SCI communication check is carried out, and the boot program required for flash memory erasing is automatically transferred to the RAM boot program area.



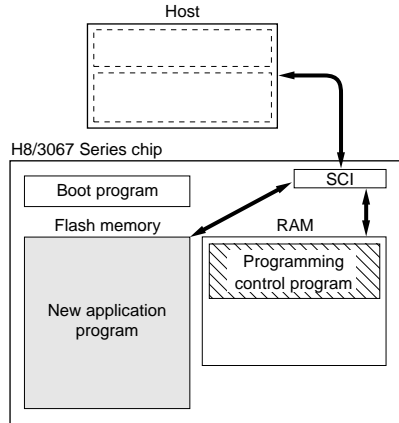
3. Flash memory initialization

The erase program in the boot program area (in RAM) is executed, and the flash memory is initialized (to H'FF). In boot mode, entire flash memory erasure is performed, without regard to blocks.



4. Writing new application program

The programming control program transferred from the host to RAM by SCI communication is executed, and the new application program in the host is written into the flash memory.



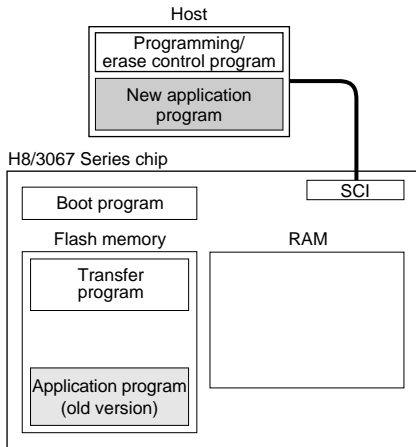
Program execution state

Figure 18.3 Boot Mode

- User program mode

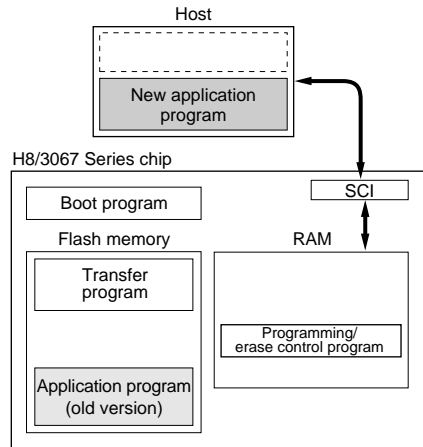
1. Initial state

(1) The program that will transfer the programming/ erase control program to on-chip RAM should be written into the flash memory by the user beforehand. (2) The programming/erase control program should be prepared in the host or in the flash memory.



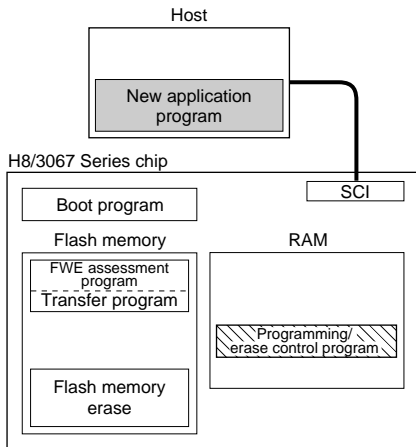
2. Programming/erase control program transfer

When the FWE pin is driven high, user software confirms this fact, executes the transfer program in the flash memory, and transfers the programming/erase control program to RAM.



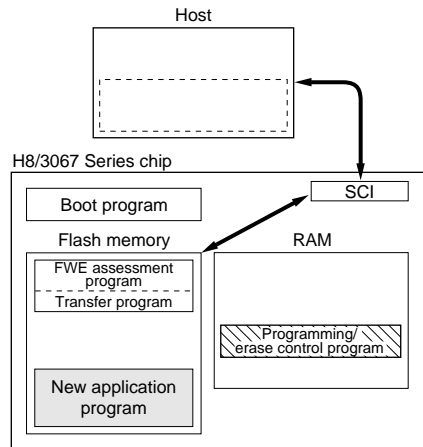
3. Flash memory initialization


The programming/erase program in RAM is executed, and the flash memory is initialized (to H'FF). Erasing can be performed in block units, but not in byte units.



4. Writing new application program

Next, the new application program in the host is written into the erased flash memory blocks. Do not write to unerased blocks.



 Program execution state

**Figure 18.4 User Program Mode (Example)**

## 18.4.1 Boot Mode

When boot mode is used, the flash memory programming control program must be prepared in the host beforehand. The channel 1 SCI to be used is set to asynchronous mode.

In reset start, after setting this LSI pin to the boot mode, start the microcomputer boot program, measure the Low period of the data sent from the host, and select the bit rate register (BRR) value beforehand. Then enable reception of the user program from the outside using the serial communication interface (SCI) on this LSI, and write the received user program to on-chip RAM.

After the program has been stored the end of writing, execution branches to the top address (H'FFF400) of the on-chip RAM, execute the program written on the on-chip RAM, and enable flash memory program/erase.

The system configuration in boot mode is shown in figure 18.5, and the boot program mode execution procedure in figure 18.6.

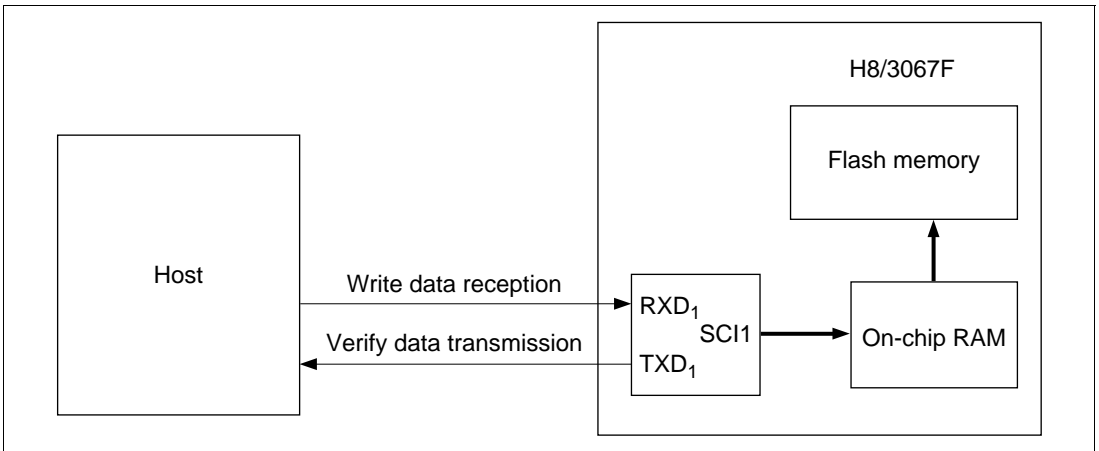
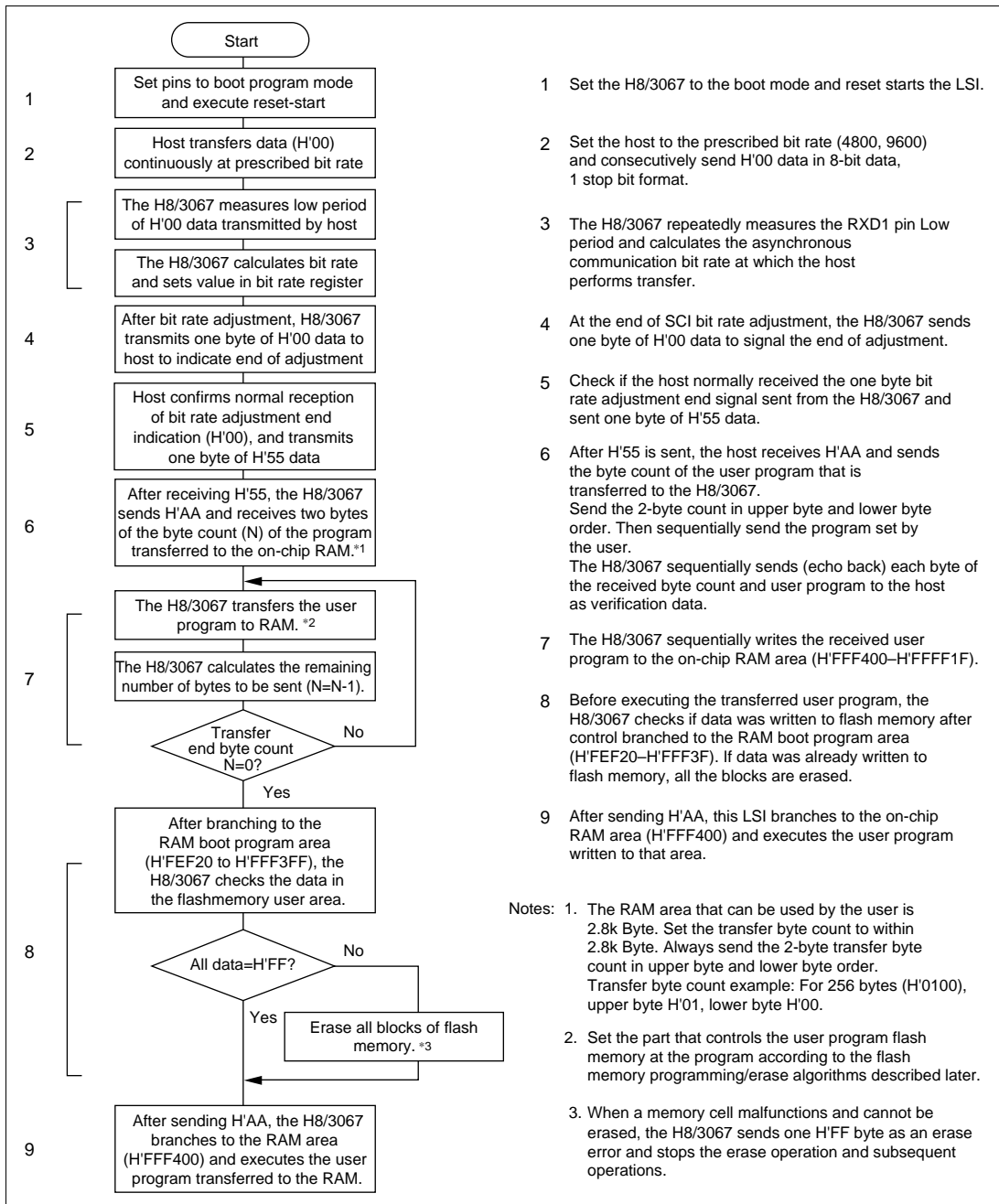
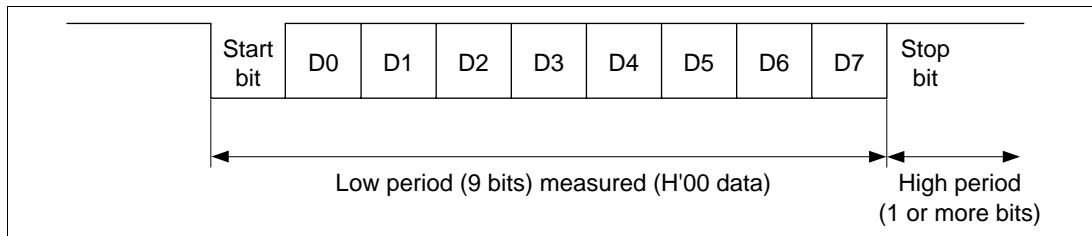


Figure 18.5 System Configuration in Boot Mode



**Figure 18.6 Boot Mode Execution Procedure**

## Automatic SCI Bit Rate Adjustment



**Figure 18.7 Measuring the low period of the communication data from the host**

When boot mode is initiated, this LSI measures the low period of the asynchronous SCI communication data (H'00) transmitted continuously from the host (figure 18.7). The SCI transmit/receive format should be set as follows: 8-bit data, 1 stop bit, no parity. This LSI calculates the bit rate of the transmission from the host from the measured low period, and transmits one H'00 byte to the host to indicate the end of bit rate adjustment. The host should confirm that this adjustment end indication (H'00) has been received normally, and transmit one H'55 byte to the LSI. If reception cannot be performed normally, initiate boot mode again (reset), and repeat the above operations. Depending on the host's transmission bit rate and the system clock frequency of this LSI, there will be a discrepancy between the bit rates of the host and the LSI. To ensure correct SCI operation, the host's transfer bit rate should be set to 4800 and 9600 bps\*<sup>1</sup>.

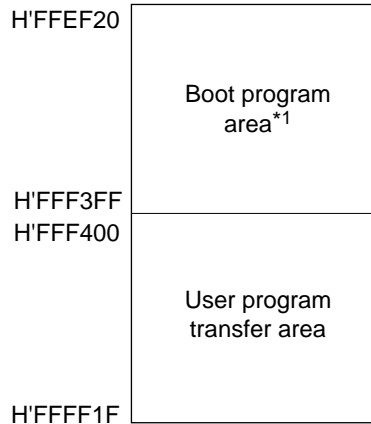
Table 18.7 shows typical host transfer bit rates and system clock frequencies for which automatic adjustment of this LSI bit rate is possible. The boot program should be executed within this system clock range\*<sup>2</sup>.

**Table 18.7 System Clock Frequencies for which Automatic Adjustment of This LSI Bit Rate is Possible**

Host Bit Rate (bps)	System Clock Frequency for which Automatic Adjustment of This LSI Bit Rate is Possible (MHz)
9600	8 to 20
4800	4 to 20

- Notes: 1. The host bit rate settings are 4800 and 9600bps only. Do not use any other setting.  
 2. This LSI may automatically adjust the bit rate except for bit rate and system clock combinations as shown in Table 18.7. However, the bit rate of the host and this LSI will be different and subsequent transfers will not be carried out normally. Therefore, always execute the boot mode within the range of the bit rate and system clock combinations shown in Table 18.7.

**On-Chip RAM Area Divisions in Boot Mode:** In boot mode, the RAM area is divided into an area used by the boot program and an area to which the user program is transferred via the SCI, as shown in figure 18.8. The boot program area can be used when a transition is made to the execution state for the user program transferred to RAM.



Note : 1. The boot program area cannot be used until a transition is made to the execution state for the user program transferred to RAM. Note also that the boot program remains in this RAM area even after control branches to the user program.

**Figure 18.8 RAM Areas in Boot Mode**

### Notes on using the boot mode

- (1) When this LSI comes out of reset in boot mode, it measures the low period the input at the SCI's RXD<sub>1</sub> pin. The reset should end with RXD<sub>1</sub> high. After the reset ends, it takes about 100 states for this LSI to get ready to measure the low period of the RXD<sub>1</sub> input.
- (2) If any data has been written to the flash memory (if all data is not H'FF), all flash memory blocks are erased when this mode is executed. Therefore, boot mode should be used for initial on-board programming, or for forced recovery if the program to be activated in user program mode is accidentally erased and user program mode cannot be executed, for example.
- (3) Interrupts cannot be used during programming or erasing of flash memory.
- (4) The RXD<sub>1</sub> and TXD<sub>1</sub> pins should be pulled up on the board.



(5) This LSI terminates transmit and receive operations by the on-chip SCI(channel 1) (by clearing the RE and TE bits in serial control register (SCR)) before branching to the user program.

However, the adjusted bit rate is held in the bit rate register (BRR). At this time, the TXD<sub>1</sub> pin is in the high level output state (P9DDR P9<sub>1</sub>DDR=1, P9DR P9<sub>1</sub>DR=1).

Before branching to the user program the value of the general registers in the CPU are also undefined. Therefore, the general registers must be initialized immediately after control branches to the user program. Since the stack pointer (SP) is implicitly used during subroutine call, etc., a stack area must be specified for use by the user program.

There are no other internal I/O registers in which the initial value is changed.

(6) Transition to the boot mode executes a reset-start of this LSI after setting the MD0 to MD2 and FWE pins according to the mode setting conditions shown in Table 18.6.

At this time, this LSI latches the status of the mode pin inside the microcomputer to maintain the boot mode status at the reset clear (startup with Low -> High) timing\*<sup>1</sup>.

To clear boot mode, it is necessary to drive the FWE pin low during the reset, and then execute reset release\*<sup>1</sup>. The following points must be noted:

(a) Before making a transition from the boot mode to the regular mode, the microcomputer boot mode must be reset by reset input via the  $\overline{\text{RES}}$  pin. At this time, the  $\overline{\text{RES}}$  pin must be hold at low level for at least 20 system clock. \*<sup>3</sup>

(b) Do not change the input levels at the mode pins (MD<sub>2</sub> to MD<sub>0</sub>) or the FWE pin while in boot mode. When making a mode transition, first enter the reset state by inputting a low level to the  $\overline{\text{RES}}$  pin. When a watchdog timer reset was generated in the boot mode, the microcomputer mode is not reset and the on-chip boot program is restarted regardless of the state of the mode pin.

(c) Do not input low level to the FWE pin while the boot program is executing and when programming/erasing flash memory. \*<sup>2</sup>

(7) If the mode pin and FWE pin input levels are changed from 0 V to V<sub>CC</sub> or from V<sub>CC</sub> to 0V during a reset (while a low level is being input to the  $\overline{\text{RES}}$  pin), the microcomputer's operating mode will change.

Therefore, since the state of the address dual port and bus control output signals ( $\overline{\text{AS}}$ ,  $\overline{\text{RD}}$ ,  $\overline{\text{HWR}}$ ,  $\overline{\text{LWR}}$ ) changes, use of these pins as output signals during reset must be disabled outside the microcomputer.

- Notes: 1. The mode pin and FWE pin input must satisfy the mode programming setup time (t<sub>MDS</sub>) relative to the reset clear timing.
2. For notes on FWE pin High/Low, see section 18.9, Notes on Flash Memory Programming/Erasing.
3. See section 4.2.2, Reset Sequence and 18.9, Notes on Flash Memory Programming/Erasing. With the mask ROM version of the H8/3067, H8/3066, and H8/3065, the minimum reset period during operation is 10 system clocks. However, the flash memory and flash memory R versions of the H8/3037 requires a minimum of 20 system clocks.

## 18.4.2 User Program Mode

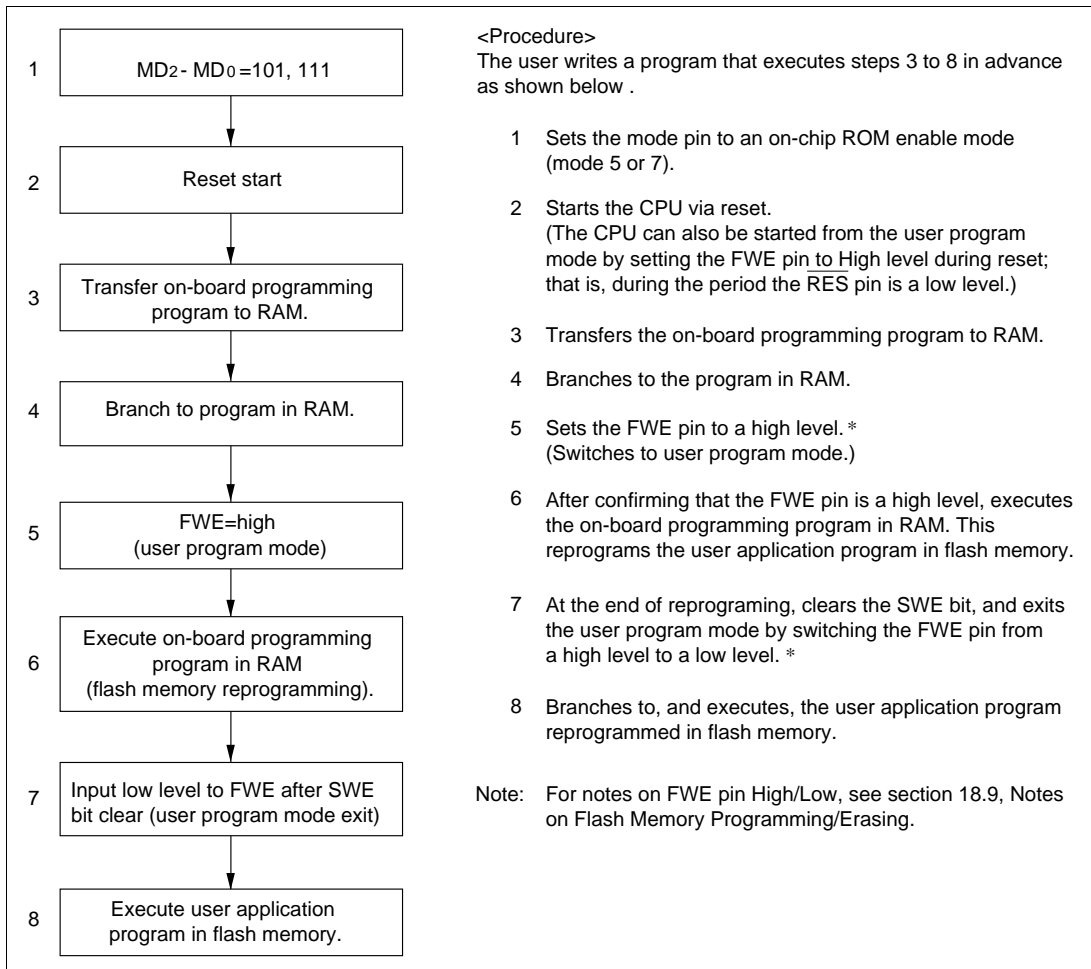
When set to the user program mode, this LSI can erase and program its flash memory by executing a user program. Therefore, on-chip flash memory on-board programming can be performed by providing a means of controlling FWE and supplying the write data on the board and providing a write program in a part of the program area.

To select this mode, set the LSI to on-chip ROM enable modes 5 and 7 and apply a high level to the FWE pin. In this mode, the peripheral functions, other than flash memory, are performed the same as in modes 5 and 7.

In mode 6, do not program/erase the flash memory. When setting mode 6, always input low level to the FWE pin.

Since the flash memory cannot be read while it is being programmed/erased, place a programming program on external memory, or transfer the programming program to RAM area, and execute it in the RAM.

Figure 18.9 shows the procedure for executing when transferred to on-chip RAM. During reset start, starting from the user program mode is possible.



**Figure 18.9 User Program Mode Execution Procedure (Example)**

- Notes:
1. Normally do not apply a high level to the FWE pin. To prevent erroneous programming or erasing in the event of program runaway, etc., apply a high level to the FWE pin only when programming/erasing flash memory (including flash memory emulation by RAM). If program runaway, etc. causes overprogramming or overerasing of flash memory, the memory cells will not operate normally. Also, while a high level is applied to the FWE pin, the watchdog timer should be activated to prevent overprogramming or overerasing due to program runaway, etc.
  2. In mode 6, do not reprogram flash memory. When setting mode 6, always set the FWE pin to a low level.

## 18.5 Programming/Erasing Flash Memory

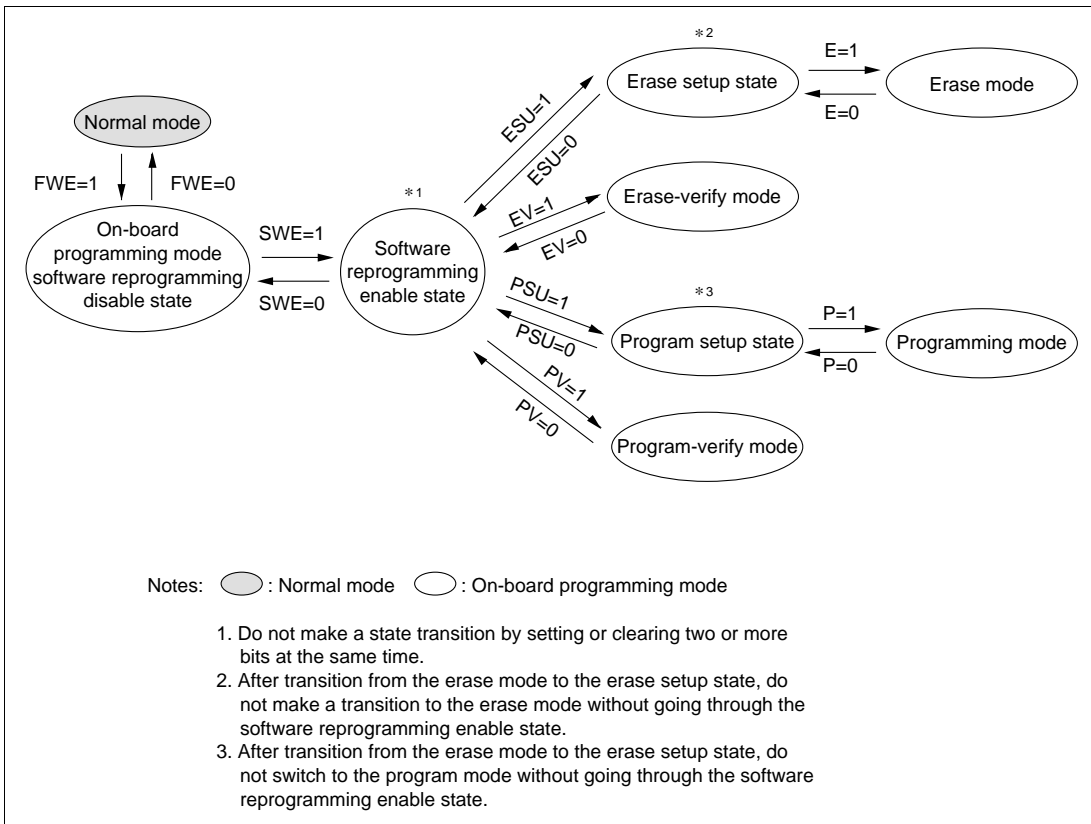
A software method, using the CPU, is employed to program and erase flash memory in the on-board programming modes. There are four flash memory operating modes: program mode, erase mode, program-verify mode, and erase-verify mode. Transitions to these modes can be made by setting the PSU, P, E, PV, and EV bits in FLMCR.

For a description of state transition by FLMCR bit setting, see figure 18.10.

The flash memory cannot be read while being programmed or erased. Therefore, the program that controls flash memory programming/erasing (the programming control program) should be located and executed in on-chip RAM or external memory.

For the programming/erasing notes, see section 18.9, Notes on Flash Memory Programming/Erasing. For the wait time after each bit in FLMCR is set or cleared, see section 21.2.6, Flash Memory Characteristics.

- Notes:
1. Operation is not guaranteed if setting/resetting of the SWE, ESU, PSU, EV, PV, E, and P bits in FLMCR is executed by a program in flash memory.
  2. When programming or erasing, set the FWE pin input level to the high level, and set FWE to 1. (programming/erasing will not be executed if FWE = 0).



**Figure 18.10 State Transition by Setting of Each Bit of FLMCR**

### 18.5.1 Program Mode

Follow the procedure shown in the program/program-verify flowchart in figure 18.11 to write data or programs to flash memory. Performing program operations according to this flowchart will enable data or programs to be written to flash memory without subjecting the device to voltage stress or sacrificing program data reliability. Programming should be carried out 32 bytes at a time.

For the wait time ( $x, y, z, \alpha, \beta, \gamma, \epsilon, \eta$ ) after setting or clearing each bit in the flash memory control register (FLMCR) and the maximum programming count ( $N$ ), see table 21.19 in section 21.2.6, Flash Memory Characteristics.

Following the elapse of  $(x)$   $\mu\text{s}$  or more after the SWE bit is set to 1 in flash memory control register (FLMCR), 32-byte program data is stored in the program data area and reprogram data area, and the 32-byte data in the reprogram data area written consecutively to the write addresses. (The lower 8 bits of the first address written to must be H'00, H'20, H'40, H'60, H'80, H'A0, H'C0, or H'E0.) 32 consecutive byte data transfers are performed. The program address and program data are latched in the flash memory. A 32-byte data transfer must be performed even if writing fewer than 32 bytes; in this case, H'FF data must be written to the extra addresses.

Next, the watchdog timer (WDT) is set to prevent overprogramming due to program runaway, etc. Set a value greater than  $(y + z + \alpha + \beta)$   $\mu\text{s}$  as the WDT overflow period. Preparation for entering program mode (program setup) is performed next by setting the PSU bit in FLMCR. The operating mode is then switched to program mode by setting the P bit in FLMCR after the elapse of at least  $(y)$   $\mu\text{s}$ .

The time while the P bit is set is the flash memory programming time. Make a program setting so that the time for one programming operation is within the range of  $(z)$   $\mu\text{s}$ .

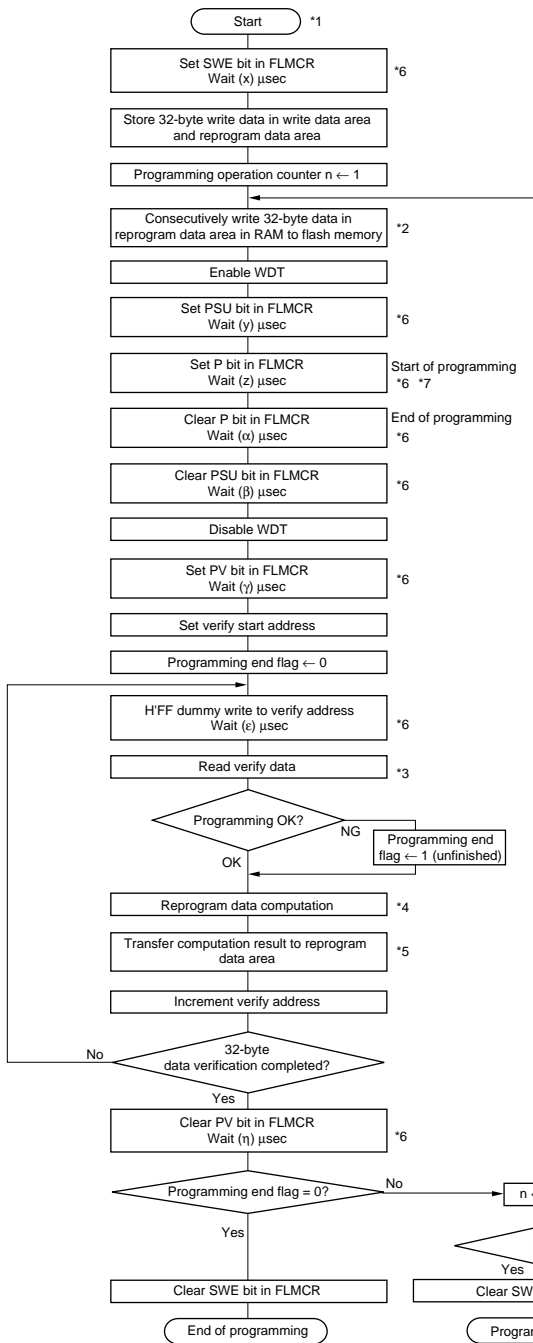
The wait time after P bit setting must be changed according to the number of reprogramming loops. For details, see section 21.2.6, Flash Memory Characteristics.

### 18.5.2 Program-Verify Mode

In program-verify mode, the data written in program mode is read to check whether it has been correctly written in the flash memory.

Clear the P bit in FLMCR, then wait for at least  $(\alpha)$   $\mu\text{s}$  before clearing the PSU bit to exit program mode. After exiting program mode, the watchdog timer setting is also cleared. Then the operating mode is switched to program-verify mode by setting the PV bit in FLMCR. Before reading in program-verify mode, a dummy write of H'FF data should be made to the addresses to be read. The dummy write should be executed after the elapse of  $(\gamma)$   $\mu\text{s}$  or more. When the flash memory is read in this state (verify data is read in 16-bit units), the data at the latched address is read. Wait at least  $(\epsilon)$   $\mu\text{s}$  after the dummy write before performing this read operation. Next, the originally written data is compared with the verify data, and reprogram data is computed (see figure 18.11) and transferred to RAM. After verification of 32 bytes of data has been completed, exit program-verify mode, wait for at least  $(\eta)$   $\mu\text{s}$ , then determine whether 32-byte programming has finished. If reprogramming is necessary, set program mode again, and repeat the program/program-verify sequence as before. However, ensure that the program/program-verify sequence is not repeated more than  $(N)$  times on the same bits.

Note: A 32-byte area to store program data and a 32-byte area to store reprogram data are required in RAM.



- Notes:
1. Programming should be performed in the erased state. (Perform 32-byte programming on memory after all 32 bytes have been erased.)
  2. Data transfer is performed by byte transfer (word transfer is not possible), with the write start address at a 32-byte boundary. The lower 8 bits of the first address written to must be H'00, H'20, H'40, H'60, H'80, H'A0, H'C0, or H'E0. A 32-byte data transfer must be performed even if writing fewer than 32 bytes; in this case, H'FF data must be written to the extra addresses.
  3. Verify data is read in 16-bit (word) units. (Byte-unit reading is also possible.)
  4. Reprogram data is determined by the computation shown in the table below (comparison of data stored in the program data area with verify data). Programming of reprogram data 0 bits is executed in the next programming loop. Therefore, even bits for which programming has been completed will be programmed again if the result of the subsequent verify operation is NG.
  5. An area for storing write data (32 bytes) and an area for storing reprogram data (32 bytes) must be provided in RAM. The contents of the latter are rewritten in accordance with the reprogramming data computation.
  6. The values of x, y, z, α, β, γ, ε, η, and N are shown in section 21.2.6, Flash Memory Characteristics.
  7. The value of z depends on the number of reprogramming loops (n). Details are given in section 21.2.6, Flash Memory Characteristics.

Write Data	Verify Data	Reprogram Data	Comments
0	0	1	Programming completed
0	1	0	Programming incomplete; reprogram
1	0	1	—
1	1	1	Still in erased state; no action

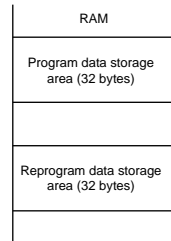


Figure 18.11 Program/Program-Verify Flowchart

### 18.5.3 Erase Mode

Flash memory erasing should be performed block by block following the procedure shown in the erase/erase-verify flowchart (single-block erase) shown in figure 18.12.

For the wait time ( $x$ ,  $y$ ,  $z$ ,  $\alpha$ ,  $\beta$ ,  $\gamma$ ,  $\epsilon$ ,  $\eta$ ) after setting or clearing of each bit in the flash memory control register (FLMCR and the maximum erase count ( $N$ )), see table 21.19 of section 21.2.6, Flash Memory Characteristics.

To erase the contents of flash memory, make a 1 bit setting for the flash memory area to be erased in erase block register (EBR) at least ( $x$ )  $\mu$ s after setting the SWE bit to 1 in FLMCR. Next, the watchdog timer (WDT) is set to prevent overerasing due to program runaway, etc. Set a value greater than ( $z$ ) ms + ( $y + \alpha + \beta$ )  $\mu$ s as the WDT overflow period. Preparation for entering erase mode (erase setup) is performed next by setting the ESU bit in FLMCR. The operating mode is then switched to erase mode by setting the E bit in FLMCR after the elapse of at least ( $y$ )  $\mu$ s.

The time during which the E bit is set is the flash memory erase time. Ensure that the erase time does not exceed ( $z$ ) ms.

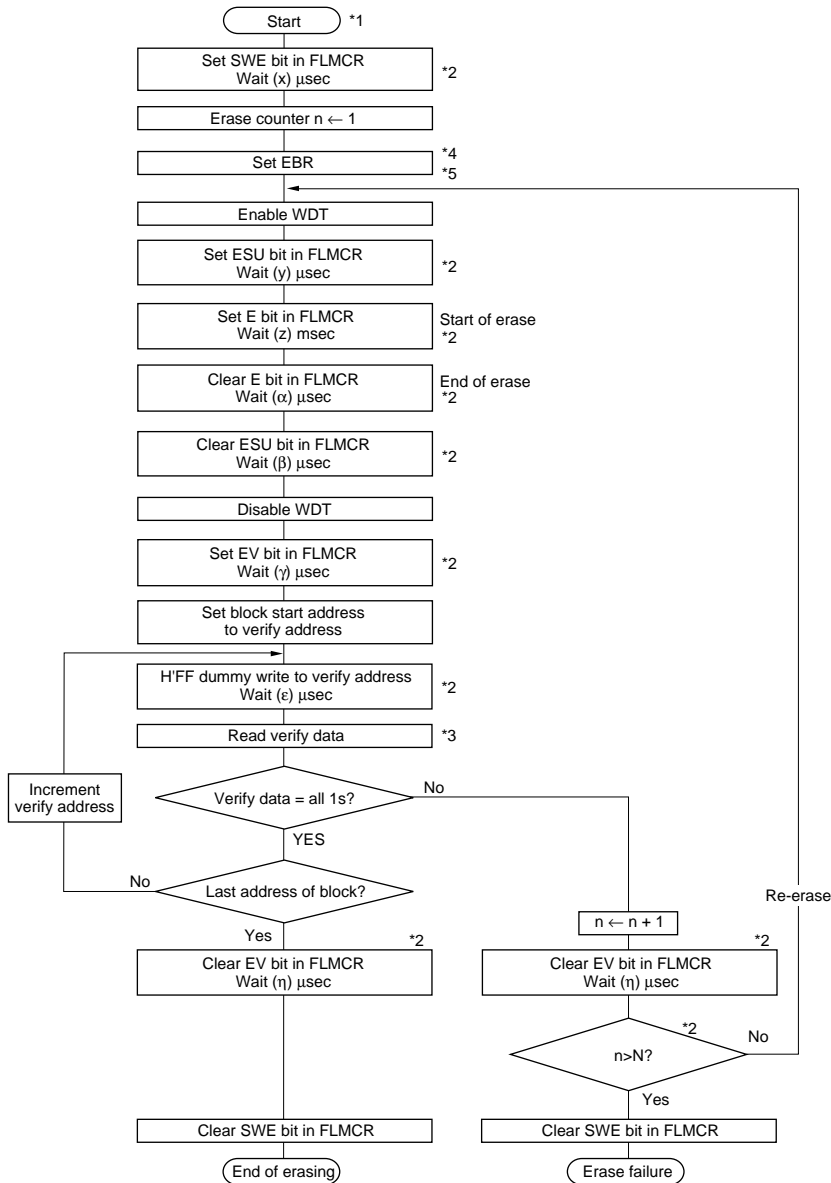
Note: With flash memory erasing, preprogramming (setting all data in the memory to be erased to “0”) is not necessary before starting the erase procedure.

### 18.5.4 Erase-Verify Mode

In erase-verify mode, data is read after memory has been erased to check whether it has been correctly erased.

After the elapse of the fixed erase time, clear the E bit in FLMCR, then wait for at least ( $\alpha$ )  $\mu$ s before clearing the ESU bit to exit erase mode. After exiting erase mode, the watchdog timer setting is also cleared. The operating mode is then switched to erase-verify mode by setting the EV bit in FLMCR. Before reading in erase-verify mode, a dummy write of H'FF data should be made to the addresses to be read. The dummy write should be executed after the elapse of ( $\gamma$ )  $\mu$ s or more. When the flash memory is read in this state (verify data is read in 16-bit units), the data at the latched address is read. Wait at least ( $\epsilon$ )  $\mu$ s after the dummy write before performing this read operation. If the read data has been erased (all “1”), a dummy write is performed to the next address, and erase-verify is performed. If the read data is unerased, set erase mode again, and repeat the erase/erase-verify sequence as before. However, do not repeat the erase/erase-verify sequence more than ( $N$ ) times.





- Notes:
1. Preprogramming (setting erase block data to all 0s) is not necessary.
  2. The values of  $x$ ,  $y$ ,  $z$ ,  $\alpha$ ,  $\beta$ ,  $\gamma$ ,  $\epsilon$ ,  $\eta$ , and  $N$  are shown in section 21.2.6, Flash Memory Characteristics.
  3. Verify data is read in 16-bit (word) units. (Byte-unit reading is also possible.)
  4. Set only one bit in EBR two or more bits must not be set simultaneously.
  5. Erasing is performed in block units. To erase multiple blocks, each block must be erased in turn.

**Figure 18.12 Erase/Erase-Verify Flowchart (Single-Block Erasing)**

## 18.6 Flash Memory Protection

There are three kinds of flash memory program/erase protection: hardware protection, software protection, and error protection.

### 18.6.1 Hardware Protection

Hardware protection refers to a state in which programming/erasing of flash memory is forcibly disabled or aborted. Hardware protection is reset by settings in the flash memory control register (FLMCR) and erase block register (EBR). In the case of error protection, the P bit and E bit can be set, but a transition is not made to program mode or erase mode. (See table 18.8.)

**Table 18.8 Hardware Protection**

Item	Description	Function		
		Program	Erase	Verify* <sup>1</sup>
FWE pin protection	<ul style="list-style-type: none"> <li>When a low level is input to the FWE pin, FLMCR and EBR are initialized, and the program/erase-protected state is entered.*<sup>4</sup></li> </ul>	No* <sup>2</sup>	No* <sup>3</sup>	No
Reset/standby protection	<ul style="list-style-type: none"> <li>In a reset (including a WDT overflow reset) and in standby mode, FLMCR and EBR are initialized, and the program/erase-protected state is entered.</li> <li>In a reset via the <math>\overline{\text{RES}}</math> pin, the reset state is not entered unless the <math>\overline{\text{RES}}</math> pin is held low until oscillation stabilizes after powering on (The minimum oscillation stabilization time is 20ms). In the case of a reset during operation, hold the <math>\overline{\text{RES}}</math> pin low for at least 20 system clock cycles.*<sup>5</sup></li> </ul>	No	No* <sup>3</sup>	No
Error protection	<ul style="list-style-type: none"> <li>When a microcomputer operation error (error generation (FLER=1)) was detected while flash memory was being programmed/erased, error protection is enabled. At this time, the FLMCR and EBR settings are held, but programming/erasing is aborted at the time the error was generated. Error protection is released only by a reset via the <math>\overline{\text{RES}}</math> pin or a WDT reset, or in the hardware standby mode.</li> </ul>	No	No* <sup>3</sup>	Yes

- Notes:
- Two modes: program-verify and erase-verify.
  - The RAM area that overlapped flash memory is deleted.
  - All blocks become unerasable and specification by block is impossible.
  - For more information, see section 18.9, Notes on Flash Memory Programming/Erasing.
  - See sections 4.2.2, Reset Sequence and 18.9, Notes on Flash Memory Programming/Erasing. The H8/3067F requires a minimum reset time during operation of 20 system clocks.

## 18.6.2 Software Protection

Software protection can be implemented by setting the RAMS bit in RAM control register (RAMCR) and erase block register (EBR). When software protection is in effect, setting the P or E bit in flash memory control register (FLMCR) does not cause a transition to program mode or erase mode. (See table 18.9.)

**Table 18.9 Software Protection**

Item	Description	Function		
		Program	Erase	Verify* <sup>1</sup>
Emulation protection* <sup>2</sup>	<ul style="list-style-type: none"><li>Setting the RAMS bit in RAMCR sets the program/erase-protected state for all blocks.</li></ul>	No* <sup>2</sup>	No* <sup>3</sup>	Yes
Block specification protection	<ul style="list-style-type: none"><li>Erase protection can be set for individual blocks by settings in erase block register (EBR).*<sup>4</sup> However, program protection is disabled.</li><li>Setting EBR to H'00 places all blocks in the erase-protected state.</li></ul>	—	No	Yes

Notes: 1. Two modes: program-verify mode and erase-verify mode.  
2. Programming to the RAM area that overlaps flash memory is possible.  
3. All blocks become unerasable, and specification by block is impossible.  
4. Set H'00 in the EBR bits, except for erase.

## 18.6.3 Error Protection

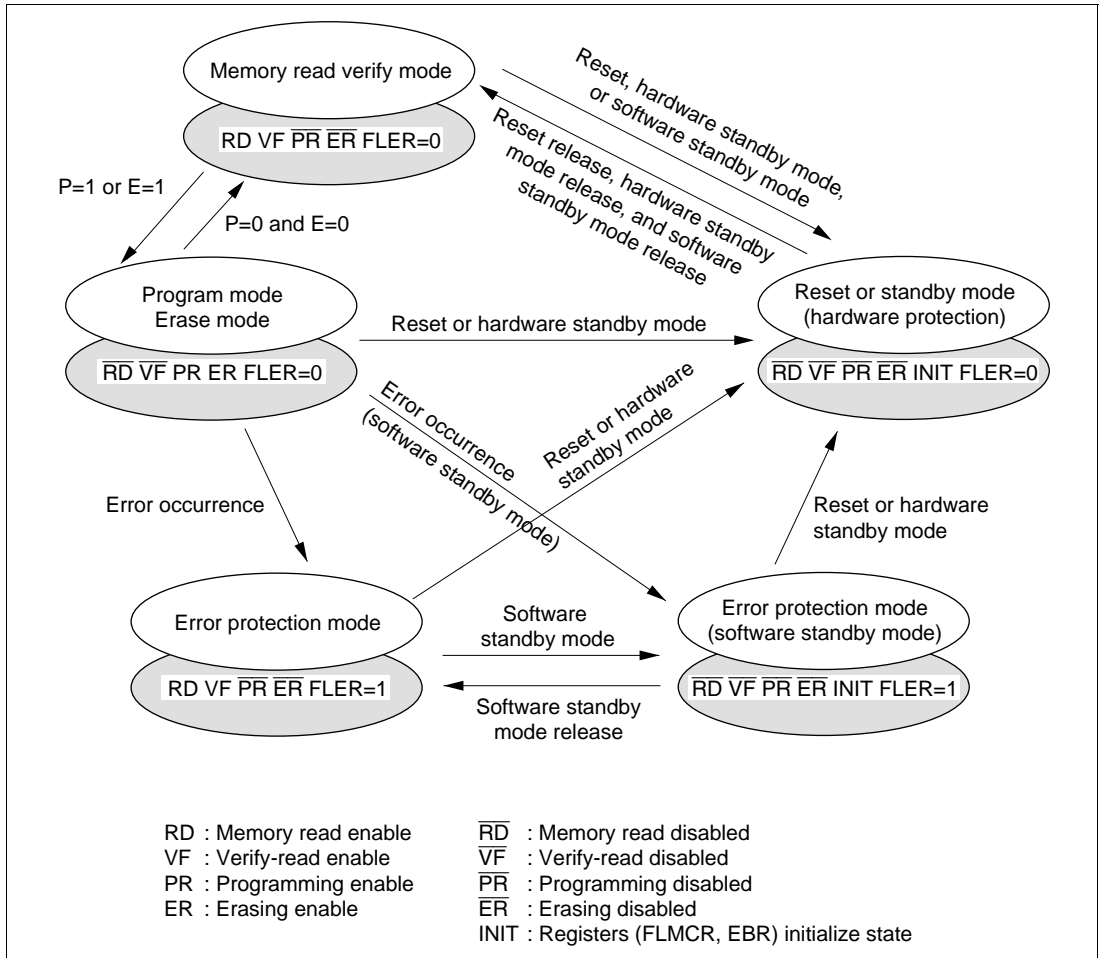
In error protection, an error is detected when this LSI runaway occurs during flash memory programming/erasing\*<sup>1</sup>, or operation is not performed in accordance with the program/erase algorithm, and the program/erase operation is aborted. Aborting the program/erase operation prevents damage to the flash memory due to overprogramming or overerasing.

If the LSI malfunctions during flash memory programming/erasing, the FLER bit\*<sup>2</sup> is set to 1 in flash memory status register (FLMSR) and the error protection state is entered. The FLMCR and EBR settings\*<sup>3</sup> are retained, but program mode or erase mode is aborted at the point at which the error occurred. When 1 is set in the FLER bit, transition to the program mode or erase mode cannot be made even by setting the P and E bits in FLMCR. However, PV and EV bit in FLMCR setting is enabled, and a transition can be made to verify mode.

Error protection is released only by a reset via the  $\overline{\text{RES}}$  pin or a WDT reset, or in the hardware standby mode.

Figure 18.13 shows the flash memory state transition diagram.

- Notes:
1. This is the state in which the P or E bit in FLMCR is set to 1. In this state, NMI input is disabled. For more information, see section 18.6.4, NMI Input Disable Conditions.
  2. For a detailed description of the FLER bits setting conditions, see section 18.3.4, Flash Memory Status Register (FLMSR).
  3. Data can be written to FLMCR and EBR. However, when transition to the software standby mode was made in the error protection state, the registers are initialized.



**Figure 18.13 Flash Memory State Transitions**  
 (When High level apply to FWE pin in modes 5 and 7 (on-chip ROM enabled))

The error protection function is disabled for errors other than the FLER bit set conditions. If considerable time elapses up to transit to this protection state, the flash memory may already be damaged. As a result, this function cannot completely protect the flash memory against damage.

Therefore, to prevent such erroneous operation, operation must be carried out correctly in according with the program/erase algorithms in the state that flash write enable (FWE) is set. In addition, the operation must be always carried out correctly by supervising microcomputer errors inside and outside the chip with the watchdog timer, etc. At transition to this protection mode, the flash memory may be erroneously programmed or erased, or its abort may result in incomplete programming and erasing. In such cases, always forcibly return (reprogram) by boot mode. However, overprogramming and overerasing may prevent the boot mode from starting normally.

#### 18.6.4 NMI Input Disable Conditions

While flash memory is being programmed/erased and the boot program is executing in the boot mode (however, period up to branching to on-chip RAM area)\*<sup>1</sup>, NMI input is disabled because the programming/erasing operations have priority.

This is done to avoid the following operation states:

1. Generation of an NMI input during programming/erasing violates the program/erase algorithms and normal operation can not longer be assured.
2. Verify-read cannot be carried out normally\*<sup>2</sup> during NMI exception handling during programming/erasing and the microcomputer runs away as a result.
3. If an NMI input is generated during boot program execution, the normal boot mode sequence cannot be executed.

Therefore, this LSI has conditions that exceptionally disable NMI inputs only in the on-board programming mode. However, this does not assure normal programming/erasing and microcomputer operation.

Thus, in the FWE application state, all requests, including NMI, inside and outside the microcomputer, exception handling, and bus release must be restricted. NMI inputs are also disabled in the error protection state and the state that holds the P or E bit in FLMCR during flash memory emulation by RAM.

Notes: 1. Indicates the period up to branching to the on-chip RAM boot program area (H'FEF20 - H'FFF3F). (This branch occurs immediately after user program transfer was completed.)

Therefore, after branching to RAM area, NMI input is enabled in states other than the program/erase state. Thus, interrupt requests inside and outside the microcomputer must be disabled until initial writing by user program (writing of vector table and NMI processing program, etc.) is completed.

2. In this case, vector read is not performed normally for the following two reasons:
  - a. The correct value cannot be read even by reading the flash memory during programming/erasing. (Value is undefined.)

- b. If a value has not yet been written to the NMI vector table, NMI exception handling will not be performed correctly.

## 18.7 Flash Memory Emulation by RAM

Erasing and programming the flash memory takes time, which can make it difficult to tune parameters and other data in real time. In this case, overlapping part (H'FFF000 to H'FFF3FF) of RAM onto a small block area of flash memory can be performed to emulate real-time reprogramming of flash memory. This RAM reassignment is performed using bits 3 to 1 in the RAM control register (RAMCR).

After the RAM area change, two areas can be accessed: the overlapped flash memory area and the original RAM area (H'FFF000 to H'FFF3FF). For a description of the RAMCR and RAM area setting procedure, see section 18.3.3 RAM Control Register (RAMCR).

### Example of real-time emulation of flash memory

An example of RAM area H'FFF000 to H'FFF3FF overlapping EB2 (H'000800 to H'000BFF) flash memory area is shown below.

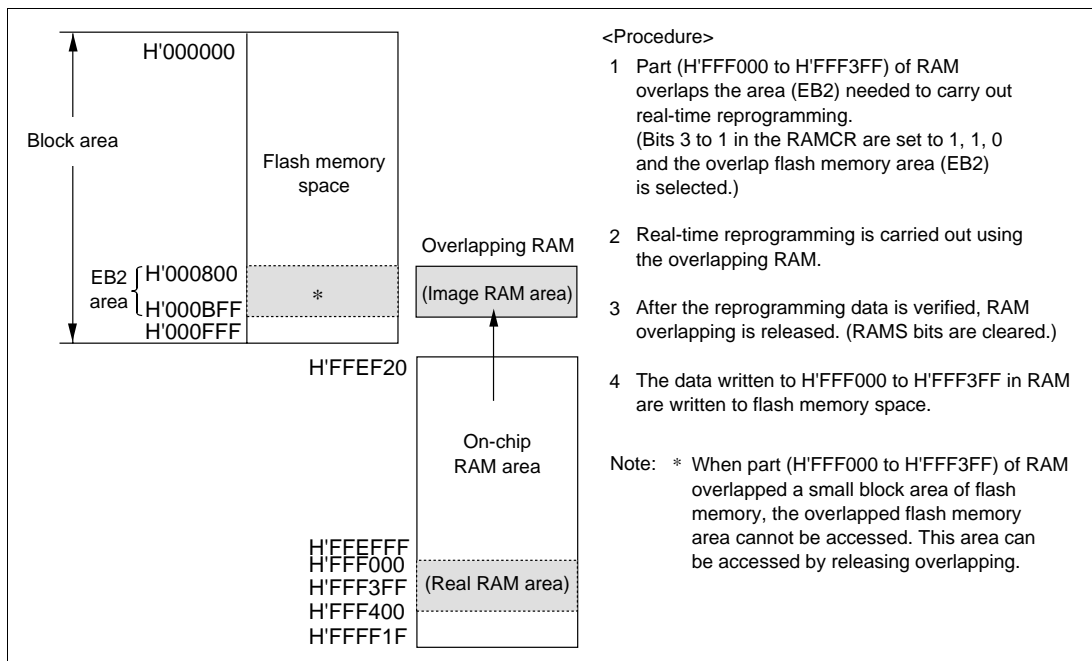


Figure 18.14 Example of RAM Overlapping Operation

## Notes on use of the RAM emulation function

### (1) Notes on flash write enable (FWE) high/low

Care is necessary to prevent erroneous programming/erasing at FWE=high/low, the same as in the on-board programming mode. To prevent erroneous programming and erasing due to program runaway, etc., during FWE application, in particular, the watchdog timer should be set when the PSU, P, ESU, or E bit is set to 1 in FLMCR, even while the emulation function is being used. For more information, see section 18.9, Notes on Flash Memory Programming/Erasing.

### (2) NMI input disable conditions

When the P and E bits in FLMCR are set, NMI input is disabled, the same as normal program/erase even when using the emulation function.

NMI input is cleared when the P and E bits are reset (including watchdog timer reset), in the standby mode, when a high level is not applied to FWE, and when the SWE bit in FLMCR is 0 in state in which a high level is input to FWE.

## 18.8 Flash Memory PROM Mode

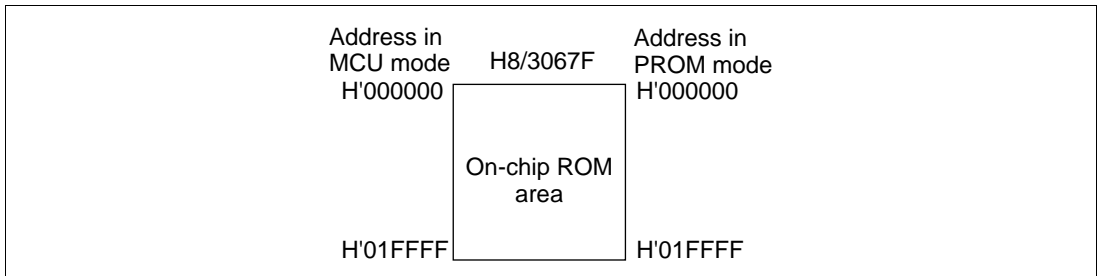
### 18.8.1 PROM Mode Setting

This LSI has a PROM mode, besides an on-board programming mode, as a flash memory program/erase mode. In the PROM mode, a program can be freely written to the on-chip ROM using a PROM writer that supports the Hitachi 128kbytes flash memory on-chip microcomputer device type.

For notes on PROM mode use, see sections 18.8.9, Notes on Memory Programming and 18.9, Notes on Flash Memory Programming/Erasing.

### 18.8.2 Memory Map

Figure 18.15 shows the PROM mode memory map.



**Figure 18.15 PROM Mode Memory Map**



### 18.8.3 PROM Mode Operation

Table 18.10 shows how the different operating modes are set when using PROM mode, and table 18.11 lists the commands used in PROM mode. Details of each mode are given below.

- **Memory Read Mode**  
Memory read mode supports byte reads.
- **Auto-Program Mode**  
Auto-program mode supports programming of 128 bytes at a time. Status polling is used to confirm the end of auto-programming.
- **Auto-Erase Mode**  
Auto-erase mode supports automatic erasing of the entire flash memory. Status polling is used to confirm the end of auto-erasing.
- **Status Read Mode**  
Status polling is used for auto-programming and auto-erasing, and normal termination can be confirmed by reading the I/O 6 signal. In status read mode, error information is output if an error occurs.

**Table 18.10 Settings for Each Operating Mode in PROM Mode**

Mode	Pin Names* <sup>3</sup>					
	FWE	$\overline{\text{CE}}$	$\overline{\text{OE}}$	$\overline{\text{WE}}$	D <sub>0</sub> to D <sub>7</sub>	A <sub>0</sub> to A <sub>17</sub>
Read	V <sub>CC</sub> or 0	L	L	H	Data output	Ain
Output disable	V <sub>CC</sub> or 0	L	H	H	Hi-z	X
Command write	V <sub>CC</sub> or 0	L	H	L	Data input	Ain* <sup>2</sup>
Chip disable* <sup>1</sup>	V <sub>CC</sub> or 0	H	X	X	Hi-z	X

L : Low level

H : High level

X : Undefined

Hi-z : High impedance

Notes: For command writes when making a transition to auto-program or auto-erase mode, input V<sub>CC</sub> (V) to FWE.

1. Chip disable is not a standby state; internally, it is an operation state.

2. Ain indicates that there is also address input in auto-program mode.

3. The pin names are those assigned in H8/3067F PROM mode.

**Table 18.11 PROM Mode Commands**

Command Name	Number of Cycles	1st Cycle			2nd Cycle		
		Mode	Address	Data	Mode	Address	Data
Memory read mode	1	Write	X	H'00	Read	RA	Dout
Auto-program mode	129	Write	X	H'40	Write	WA	Din
Auto-erase mode	2	Write	X	H'20	Write	X	H'20
Status read mode	2	Write	X	H'71	Write	X	H'71

RA : Read address

WA : Program address

Dout : Read data

Din : Program data

Notes: 1. In auto-program mode, 129 cycles are required for command writing by a simultaneous 128-byte write.

**Table 18.12 DC Characteristics in Memory Read Mode**

(Conditions:  $V_{CC} = 5.0 \text{ V} \pm 10\%$ ,  $V_{SS} = 0 \text{ V}$ ,  $T_a = 25^\circ\text{C} \pm 5^\circ\text{C}$ )

Item		Symbol	Min	Typ	Max	Unit	Test Conditions
Input high voltage	$0_7-0_0, A_{16}-A_0$	$V_{IH}$	2.2	—	$V_{CC} + 0.3$	V	
Input low voltage	$0_7-0_0, A_{16}-A_0$	$V_{IL}$	0.3	—	0.8	V	
Schmitt trigger input voltage	$\overline{OE}, \overline{CE}, \overline{WE}$	$V_T^-$	1.0	—	2.5	V	
		$V_T^+$	2.0	—	3.5	V	
		$V_T^+ - V_T^-$	0.4	—	—	V	
Output high voltage	$0_7-0_0$	$V_{OH}$	2.4	—	—	V	$I_{OH} = -200 \mu\text{A}$
Output low voltage	$0_7-0_0$	$V_{OL}$	—	—	0.45	V	$I_{OL} = 1.6 \text{ mA}$
Input leakage current	$0_7-0_0, A_{16}-A_0$	$ I_{LI} $	—	—	2	$\mu\text{A}$	
$V_{CC}$ current	Reading	$I_{CC}$	—	40	65	mA	
	Programming	$I_{CC}$	—	50	85	mA	
	Erasing	$I_{CC}$	—	50	85	mA	

Notes: For the absolute maximum ratings, see section 20.2.1, Absolute Maximum Ratings  
Exceeding the absolute maximum ratings may cause permanent damage to the chip.

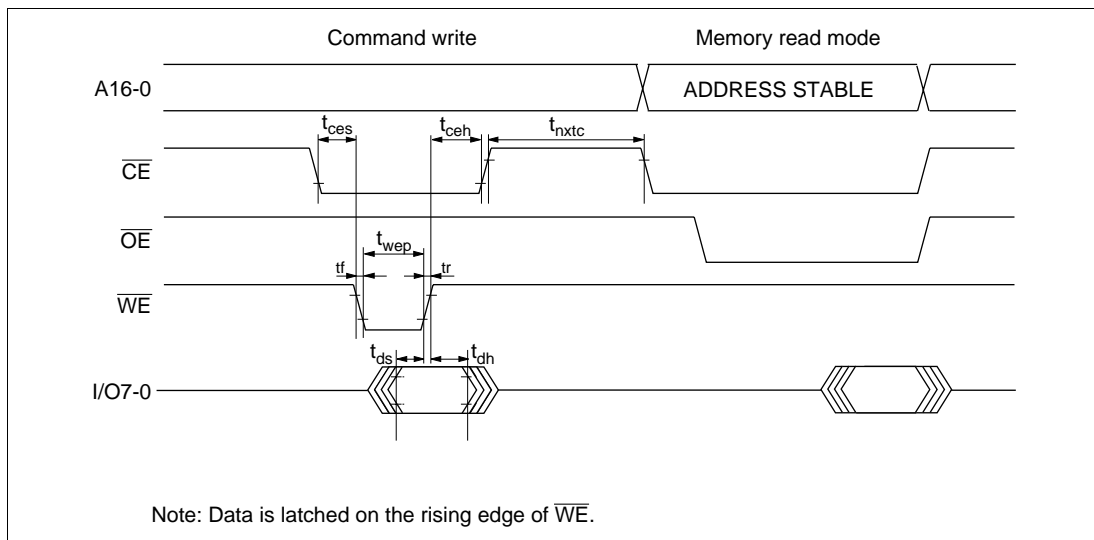
## 18.8.4 Memory Read Mode

### AC Characteristics

**Table 18.13 AC Characteristics in Memory Read Mode Transition**

(Conditions:  $V_{CC} = 5.0\text{ V} \pm 10\%$ ,  $V_{SS} = 0\text{ V}$ ,  $T_a = 25^\circ\text{C} \pm 5^\circ\text{C}$ )

Item	Symbol	Min	Max	Unit	Notes
Command write cycle	$t_{nxtc}$	20	—	$\mu\text{s}$	
$\overline{\text{CE}}$ hold time	$t_{ceh}$	0	—	ns	
$\overline{\text{CE}}$ setup time	$t_{ces}$	0	—	ns	
Data hold time	$t_{dh}$	50	—	ns	
Data setup time	$t_{ds}$	50	—	ns	
Write pulse width	$t_{wep}$	70	—	ns	
$\overline{\text{WE}}$ rise time	$t_r$	—	30	ns	
$\overline{\text{WE}}$ fall time	$t_f$	—	30	ns	



**Figure 18.16 Timing Waveform in Memory Read Mode Transition**

### Table 18.14 AC Characteristics in Memory Contents Read

(Conditions:  $V_{CC} = 5.0\text{ V} \pm 10\%$ ,  $V_{SS} = 0\text{ V}$ ,  $T_a = 25^\circ\text{C} \pm 5^\circ\text{C}$ )

Item	Symbol	Min	Max	Unit	Notes
Access time	$t_{acc}$	—	20	$\mu\text{s}$	
$\overline{\text{CE}}$ output delay time	$t_{ce}$	—	150	ns	
$\overline{\text{OE}}$ output delay time	$t_{oe}$	—	150	ns	
Output disable delay time	$t_{df}$	—	100	ns	
Data output hold time	$t_{oh}$	5	—	ns	

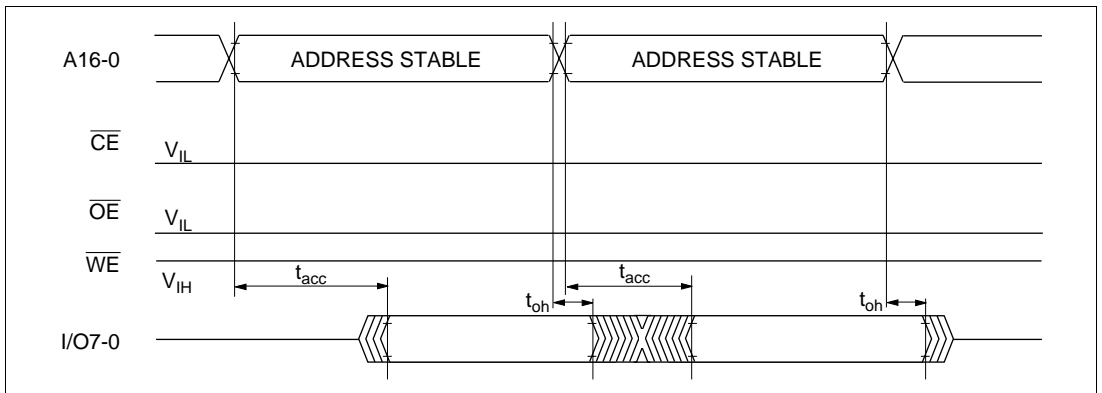


Figure 18.17  $\overline{\text{CE}}/\overline{\text{OE}}$  Enable State Read

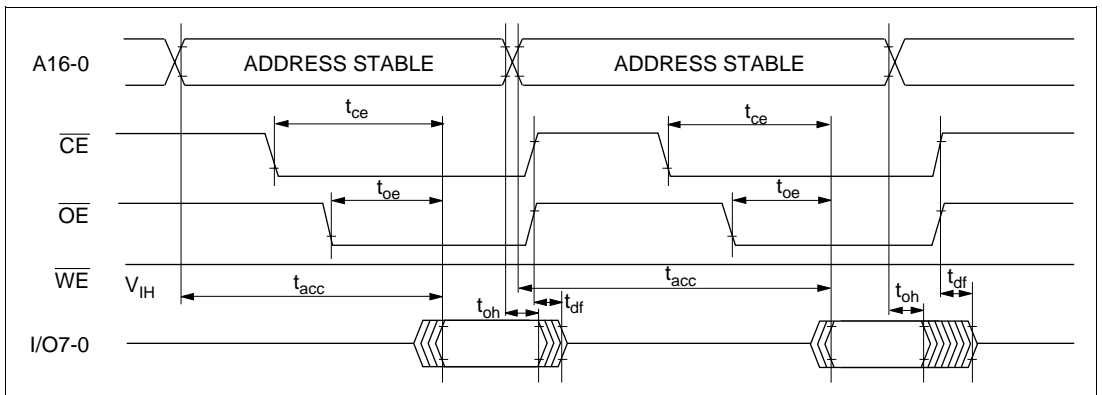
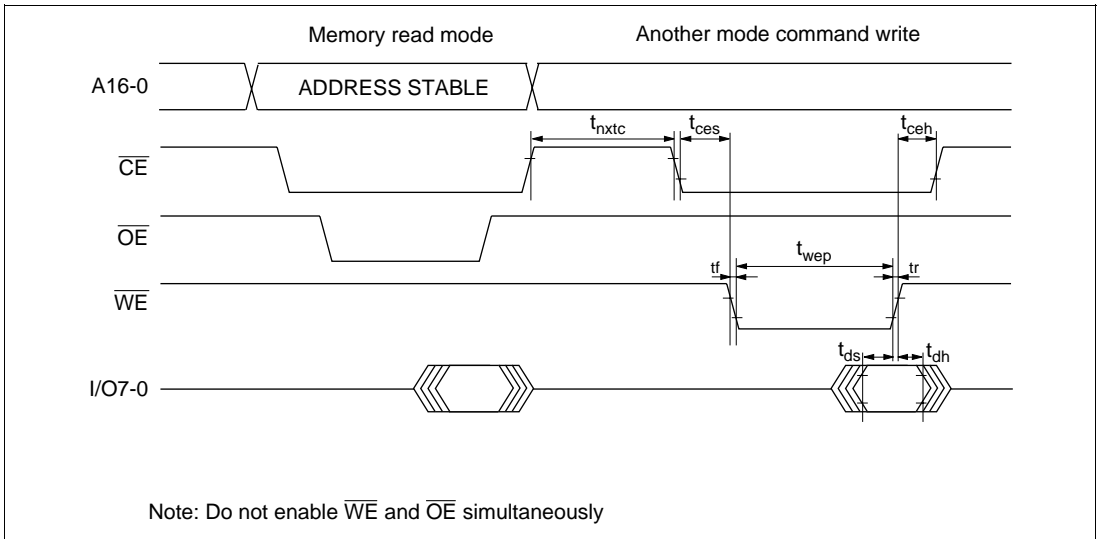


Figure 18.18  $\overline{\text{CE}}/\overline{\text{OE}}$  Clock Read

**Table 18.15 AC Characteristics in Transition from Memory Read Mode to Another Mode**

(Conditions:  $V_{CC} = 5.0 \text{ V} \pm 10\%$ ,  $V_{SS} = 0 \text{ V}$ ,  $T_a = 25^\circ\text{C} \pm 5^\circ\text{C}$ )

Item	Symbol	Min	Max	Unit	Notes
Command write cycle	$t_{nxtc}$	20	—	$\mu\text{s}$	
$\overline{\text{CE}}$ hold time	$t_{ceh}$	0	—	ns	
$\overline{\text{CE}}$ setup time	$t_{ces}$	0	—	ns	
Data hold time	$t_{dh}$	50	—	ns	
Data setup time	$t_{ds}$	50	—	ns	
Write pulse width	$t_{wep}$	70	—	ns	
$\overline{\text{WE}}$ rise time	$t_r$	—	30	ns	
$\overline{\text{WE}}$ fall time	$t_f$	—	30	ns	



**Figure 18.19 Transition From Memory Read Mode to Another Mode**

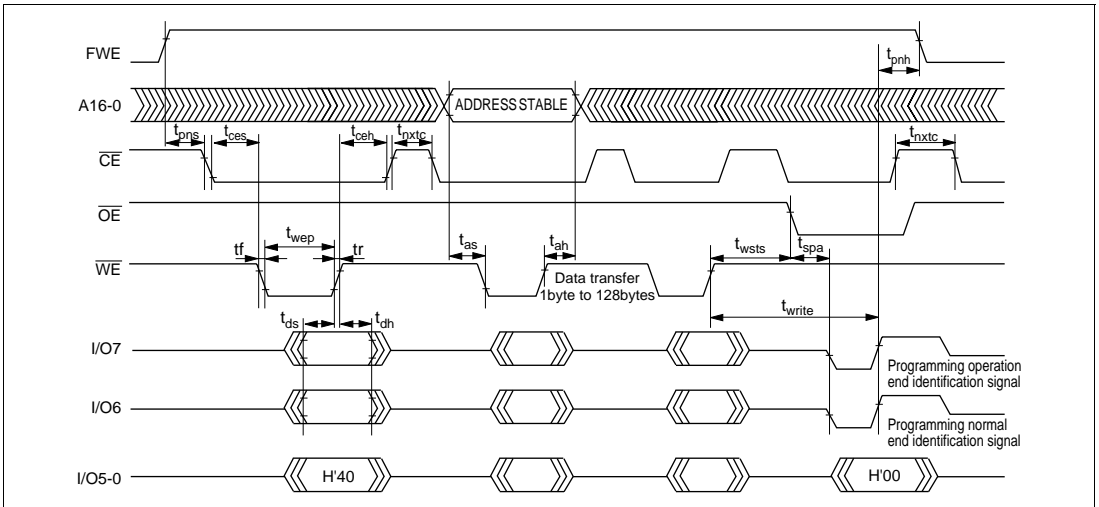
## 18.8.5 Auto-Program Mode

### AC Characteristics

**Table 18.16 AC Characteristics in Auto-Program Mode**

(Conditions:  $V_{CC} = 5.0\text{ V} \pm 10\%$ ,  $V_{SS} = 0\text{ V}$ ,  $T_a = 25^\circ\text{C} \pm 5^\circ\text{C}$ )

Item	Symbol	Min	Max	Unit	Notes
Command write cycle	$t_{nxtc}$	20	—	$\mu\text{s}$	
$\overline{\text{CE}}$ hold time	$t_{ceh}$	0	—	ns	
$\overline{\text{CE}}$ setup time	$t_{ces}$	0	—	ns	
Data hold time	$t_{dh}$	50	—	ns	
Data setup time	$t_{ds}$	50	—	ns	
Write pulse width	$t_{wep}$	70	—	ns	
Status polling start time	$t_{wsts}$	1	—	ms	
Status polling access time	$t_{spa}$	—	150	ns	
Address setup time	$t_{as}$	0	—	ns	
Address hold time	$t_{ah}$	60	—	ns	
Memory write time	$t_{write}$	1	3000	ms	
$\overline{\text{WE}}$ rise time	$t_r$	—	30	ns	
$\overline{\text{WE}}$ fall time	$t_f$	—	30	ns	
Write setup time	$t_{pns}$	100	—	ns	
Write end setup time	$t_{pnh}$	100	—	ns	



**Figure 18.20 Auto-Program Mode Timing Waveforms**

### Cautions on Use of Auto-Program Mode

- In auto-program mode, 128 bytes are programmed simultaneously. This should be carried out by executing 128 consecutive byte transfers.
- A 128-byte data transfer is necessary even when programming fewer than 128 bytes. In this case, H'FF data must be written to the extra addresses.
- If a value other than an effective address is input, processing will switch to a memory write operation but a write error will be flagged.
- Memory address transfer is performed in the second cycle (figure 18.20). Do not perform transfer after the second cycle.
- Do not perform a command write during a programming operation.
- Perform one auto-programming operation for a 128-byte block for each address. Characteristics are not guaranteed for two or more programming operations.
- Confirm normal end of auto-programming by checking I/O 6. Alternatively, status read mode can also be used for this purpose.

## 18.8.6 Auto-Erase Mode

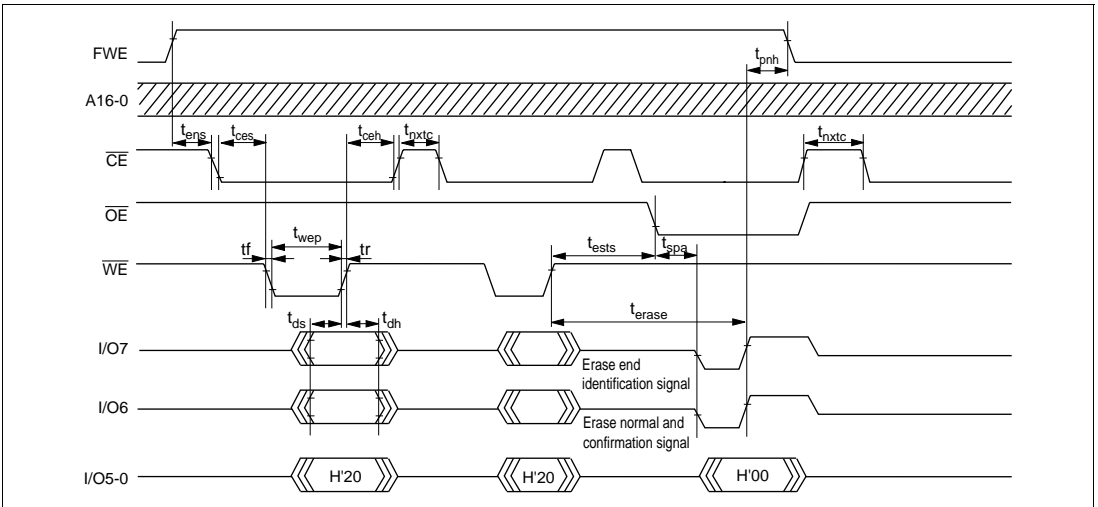
### AC Characteristics

**Table 18.17 AC Characteristics in Auto-Erase Mode**

(Conditions:  $V_{CC} = 5.0\text{ V} \pm 10\%$ ,  $V_{SS} = 0\text{ V}$ ,  $T_a = 25^\circ\text{C} \pm 5^\circ\text{C}$ )

Item	Symbol	Min	Max	Unit	Notes
Command write cycle	$t_{nxtc}$	20	—	$\mu\text{s}$	
$\overline{\text{CE}}$ hold time	$t_{ceh}$	0	—	ns	
$\overline{\text{CE}}$ setup time	$t_{ces}$	0	—	ns	
Data hold time	$t_{dh}$	50	—	ns	
Data setup time	$t_{ds}$	50	—	ns	
Write pulse width	$t_{wep}$	70	—	ns	
Status polling start time	$t_{ests}$	1	—	ms	
Status polling access time	$t_{spa}$	—	150	ns	
Memory erase time	$t_{erase}$	100	40000	ms	
$\overline{\text{WE}}$ rise time	$t_r$	—	30	ns	
$\overline{\text{WE}}$ fall time	$t_f$	—	30	ns	
Erase setup time	$t_{ens}$	100	—	ns	
Erase end setup time	$t_{enh}$	100	—	ns	





**Figure 18.21 Auto-Erase Mode Timing Waveforms**

### Caution on Use of Erase-Program Mode

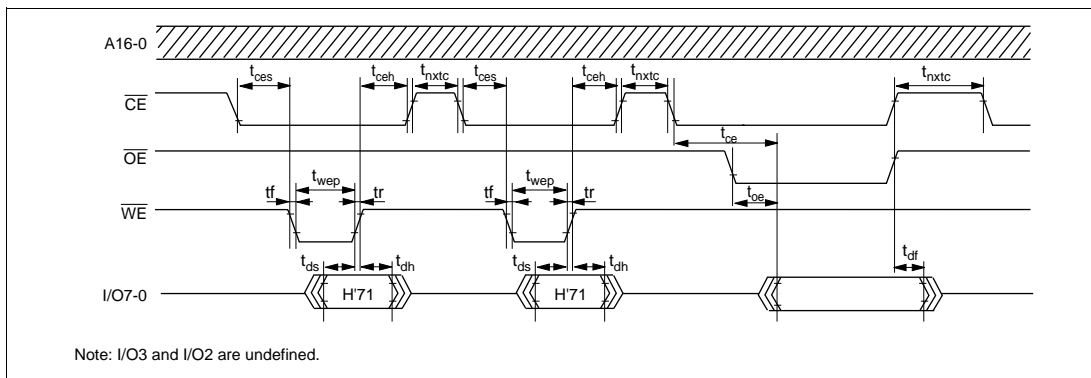
- Auto-erase mode supports only entire memory erasing.
- Do not perform a command write during auto-erasing.
- Confirm normal end of auto-erasing by checking I/O 6. Alternatively, status read mode can also be used for this purpose.

## 18.8.7 Status Read Mode

**Table 18.18 AC Characteristics in Status Read Mode**

(Conditions:  $V_{CC} = 5.0 \text{ V} \pm 10\%$ ,  $V_{SS} = 0 \text{ V}$ ,  $T_a = 25^\circ\text{C} \pm 5^\circ\text{C}$ )

Item	Symbol	Min	Max	Unit	Notes
Command write cycle	$t_{nxtc}$	20	—	$\mu\text{s}$	
$\overline{\text{CE}}$ hold time	$t_{ceh}$	0	—	ns	
$\overline{\text{CE}}$ setup time	$t_{ces}$	0	—	ns	
Data hold time	$t_{dh}$	50	—	ns	
Data setup time	$t_{ds}$	50	—	ns	
Write pulse width	$t_{wep}$	70	—	ns	
$\overline{\text{OE}}$ output delay time	$t_{oe}$	—	150	ns	
Disable delay time	$t_{df}$	—	100	ns	
$\overline{\text{CE}}$ output delay time	$t_{ce}$	—	150	ns	
$\overline{\text{WE}}$ rise time	$t_r$	—	30	ns	
$\overline{\text{WE}}$ fall time	$t_f$	—	30	ns	



**Figure 18.22 Status Read Mode Timing Waveforms**

**Table 18.19 Status Read Mode Return Commands**

Pin Name	I/O7	I/O6	I/O5	I/O4	I/O3	I/O2	I/O1	I/O0
Attribute	Normal end identification	Command error	Programming error	Erase error	—	—	Programming or erase count exceeded	Effective address error
Initial value	0	0	0	0	0	0	0	0
Indications	Normal end: 0 Abnormal end: 1	Command error: 1 Otherwise: 0	Programming error: 1 Otherwise: 0	Erase error: 1 Otherwise: 0	—	—	Count exceeded: 1 Otherwise: 0	Effective address error: 1 Otherwise: 0

**Notes on status read mode**

After exiting auto-program mode or auto-erase mode, status read mode must be executed without dropping the power supply.

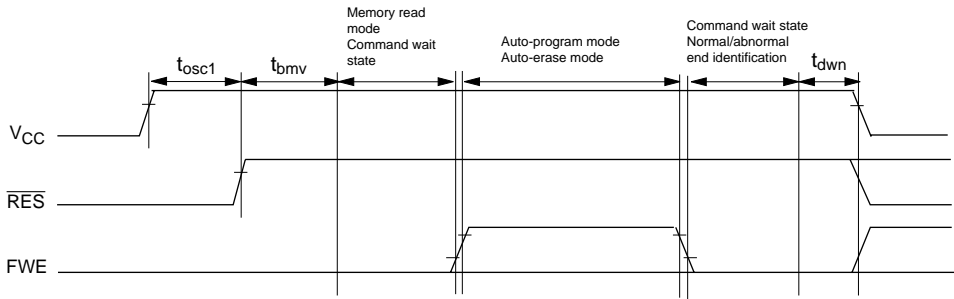
Immediately after powering on, or once powering off, the return command is undefined.

**18.8.8 PROM Mode Transition Time**

Commands cannot be accepted during the oscillation stabilization period or the PROM mode setup period. After the PROM mode setup time, a transition is made to memory read mode.

**Table 18.20 Stipulated Transition Times to Command Wait State**

Item	Symbol	Min	Max	Unit	Notes
Standby release (oscillation settling time)	$t_{osc1}$	20	—	ms	
PROM mode setup time	$t_{bmv}$	10	—	ms	
$V_{CC}$ hold time	$t_{dwn}$	0	—	ms	



Note: Set the FWE input pin low level, except in the auto-program and auto-erase modes.

**Figure 18.23 Oscillation Stabilization Time, Boot Program Transfer Time**

### 18.8.9 Notes On Memory Programming

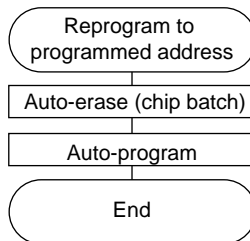
- When programming addresses which have previously been programmed, carry out auto-erasing before auto-programming (figure 18.24).
- When performing programming using PROM mode on a chip that has been programmed/erased in an on-board programming mode, auto-erasing is recommended before carrying out auto-programming.

Notes: 1. The flash memory is initially in the erased state when the device is shipped by Hitachi. For other chips for which the erasure history is unknown, it is recommended that auto-erasing be executed to check and supplement the initialization (erase) level.

2. In the PROM mode, auto-programming to a 128-byte programming unit block should be performed only once.

Do not perform additional programming to a programmed 128-byte programming unit block.

To reprogram, perform auto-programming after auto-erasing.



**Figure 18.24 Reprogramming to Programmed Address**

## 18.9 Notes on Flash Memory Programming/Erasing

The following describes notes when using the on-board programming mode, RAM emulation function, and PROM mode.

### (1) Program/erase with the specified voltage and timing.

Applied voltages in excess of the rating can permanently damage the device.

Use a PROM writer that supports the Hitachi 128kbytes flash memory on-board microcomputer device type.

Do not set the PROM writer at the HN28F101. If the PROM writer is set to the HN28F101 by mistake, a high level can be input to the FWE pin and the LSI can be destroyed.

### (2) Notes on powering on/powering off (See figures 18.25 to 18.27.)

Input a high level to the FWE pin after verifying Vcc. Before turning off Vcc, set the FWE pin to a low level.

When powering on and powering off the Vcc power supply, fix the FWE pin a low level and set the flash memory to the hardware protection mode.

Be sure that the powering on and powering off timing is satisfied even when the power is turned off and back on in the event of a power interruption, etc. If this timing is not satisfied, microcomputer runaway, etc., may cause overprogramming or overerasing and the memory cells may not operate normally.

### (3) Notes on FWE pin High/Low switching (See figures 18.25 to 18.27.)

Input FWE in the state microcomputer operation is verified. If the microcomputer does not satisfy the operation confirmation state, fix the FWE pin at a low level to set the protection mode.

To prevent erroneous programming/erasing of flash memory, note the following in FWE pin High/Low switching:

- Apply an input to the FWE pin after the Vcc voltage has stabilized within the rated voltage.  
If an input is applied to the FWE pin when the microcomputer Vcc voltage does not satisfy the rated voltage, flash memory may be erroneously programmed or erased because the microcomputer is in the unconfirmed state.
- Apply an input to the FWE pin when the oscillation has stabilized (after the oscillation stabilization time).

When turning on the Vcc power, apply an input to the FWE pin after holding the  $\overline{\text{RES}}$  pin at a low level during the oscillation stabilization time ( $t_{\text{osc1}}=20\text{ms}$ ). Do not apply an input to the FWE pin when oscillation is stopped or unstable.

- In the boot mode, perform FWE pin High/Low switching during reset.  
In transition to the boot mode, input FWE=High level and set MD<sub>2</sub> to MD<sub>0</sub> while the  $\overline{\text{RES}}$  input is low. At this time, the FWE and MD<sub>2</sub> to MD<sub>0</sub> inputs must satisfy the mode programming setup time ( $t_{\text{MDS}}$ ) relative to the reset clear timing. The mode programming setup time is necessary for  $\overline{\text{RES}}$  reset timing even in transition from the boot mode to another mode.  
In reset during operation, the  $\overline{\text{RES}}$  pin must be held at a low level for at least 20 system clocks.
- In the user program mode, FWE=High/Low switching is possible regardless of the  $\overline{\text{RES}}$  input.  
FWE input switching is also possible during program execution on flash memory.
- Apply an input to FWE when the program is not running away.  
When applying an input to the FWE pin, the program execution state must be supervised using a watchdog timer, etc.
- Input low level to the FWE pin when the SWE, ESU, PSU, EV, PV, E, and P bits in FLMCR have been cleared.  
Do not erroneously set the SWE, ESU, PSU, EV, PV, E, and P bits when FWE High/Low.

(4) Do not input a constant high level to the FWE pin.

To prevent erroneous programming/erasing in the event of program runaway, etc., input a high level to the FWE pin only when programming/erasing flash memory (including flash memory emulation by RAM). Avoid system configurations that constantly input a high level to the FWE pin. Handle program runaway, etc. by starting the watchdog timer so that flash memory is not overprogrammed/overerased even while a high level is input to the FWE pin.

(5) Program/erase the flash memory in accordance with the recommended algorithms.

The recommended algorithms can program/erase the flash memory without applying voltage stress to the device or sacrificing the reliability of the program data.

When setting the PSU and ESU bits in FLMCR, set the watchdog timer for program runaway, etc.

(6) Do not set/clear the SWE bit while a program is executing on flash memory.

Before performing flash memory program execution or data read, clear the SWE bit.

If the SWE bit is set, the flash data can be reprogrammed, but flash memory cannot be accessed for purposes other than verify (verify during programming/erase).

Similarly perform flash memory program execution and data read after clearing the SWE bit even when using the RAM emulation function with a high level input to the FWE pin.

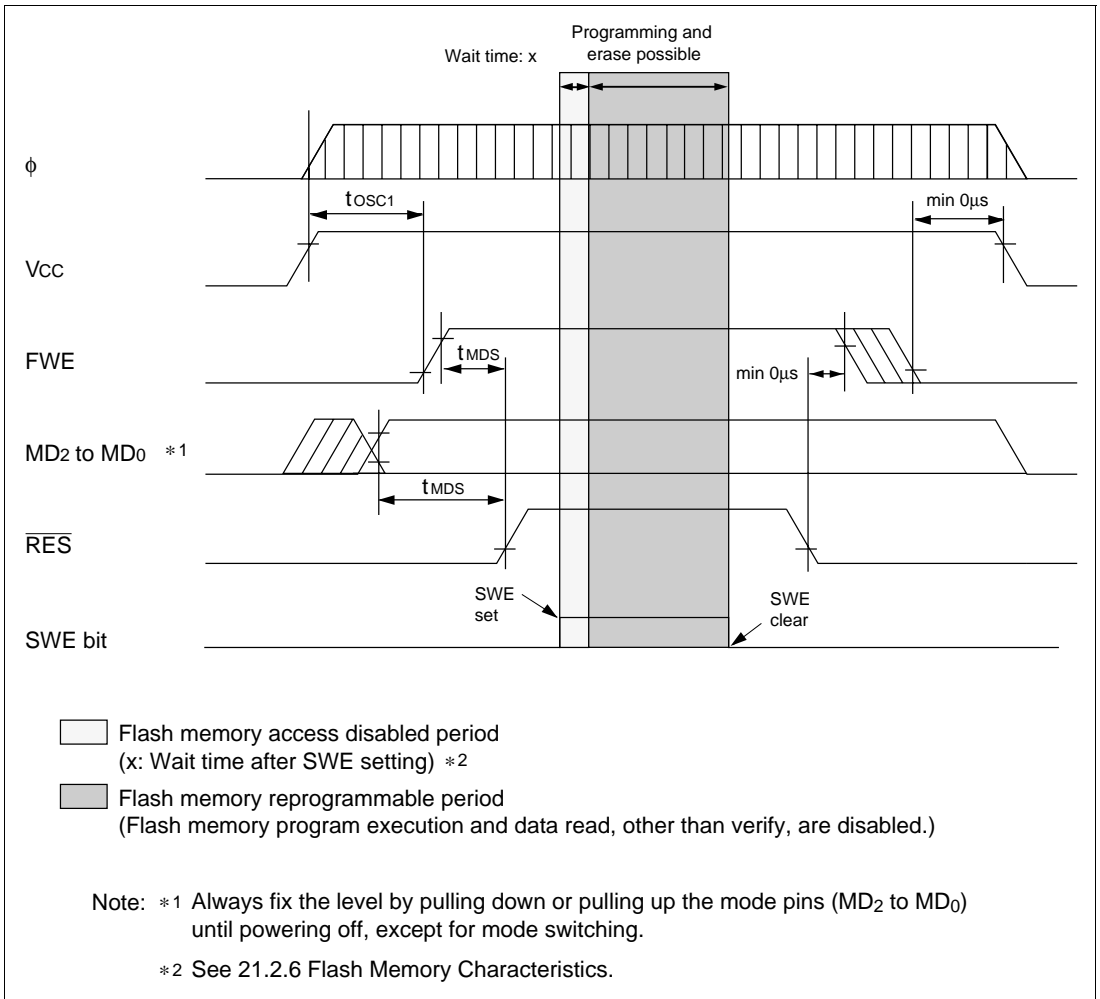
However, RAM area that overlaps flash memory space can be read/programmed whether the SWE bit is set or cleared.

(7) Do not use an interrupt during flash memory programming or erasing.

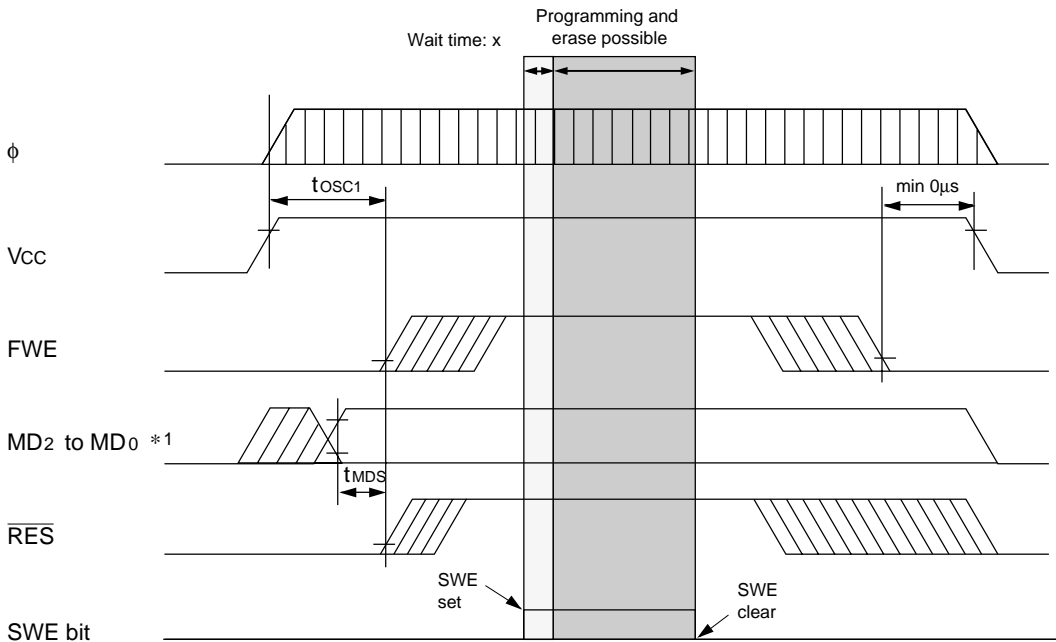
Since programming/erase operations (including emulation by RAM) have priority when a high level is input to the FWE pin, disable all interrupt requests, including NMI.

(8) Do not perform additional programming. Reprogram flash memory after erasing.

With on-board programming, program to 32-byte programming unit blocks one time only.  
 Program to 128-byte programming unit blocks one time only even in the PROM mode. Erase all the programming unit blocks before reprogramming.  
 Bus release must also be disabled.



**Figure 18.25 Powering On/Off Timing (Boot Mode)**

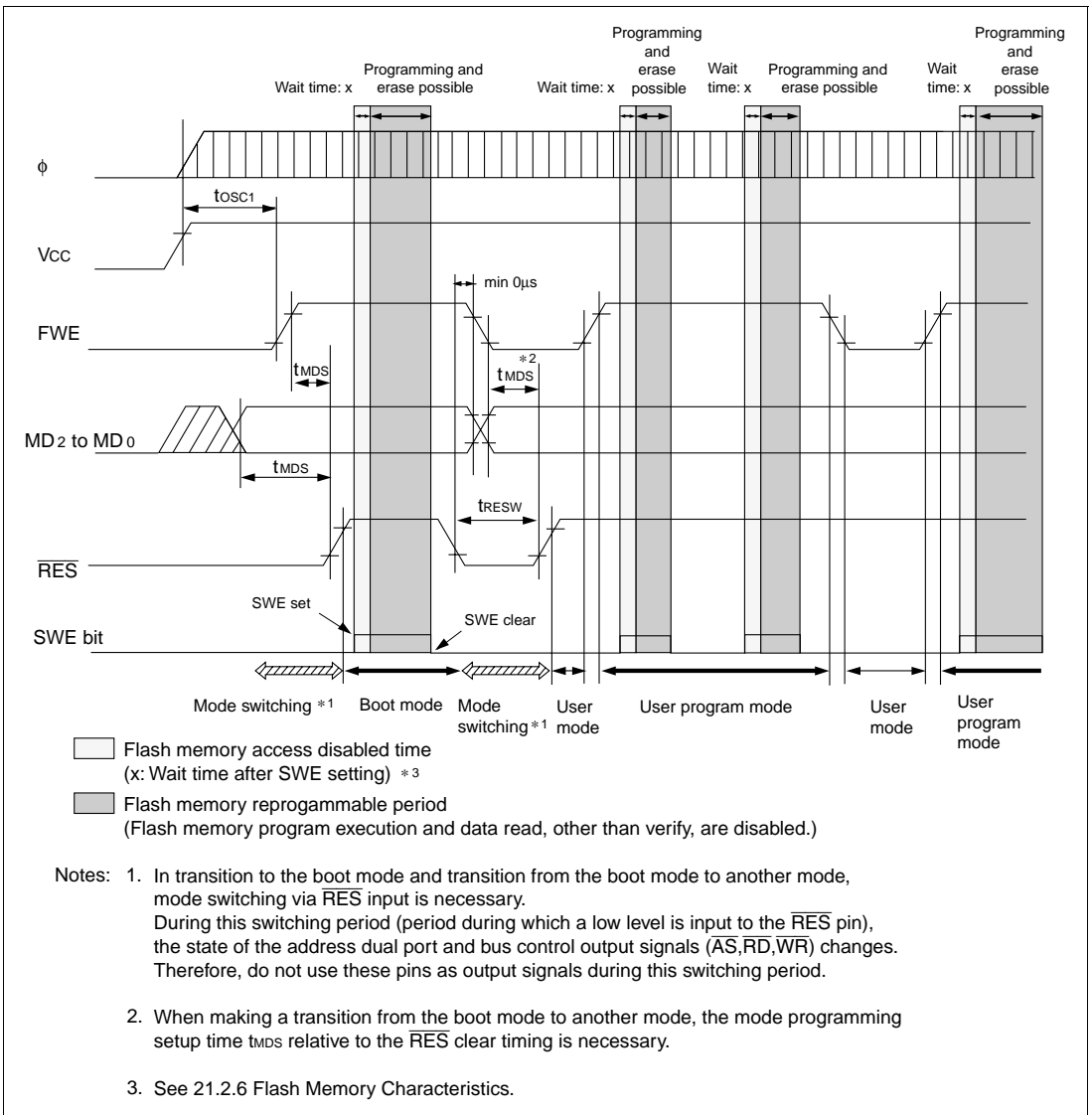


- Flash memory access disabled period  
(x: Wait time after SWE setting) \*2
- Flash memory reprogrammable period  
(Flash memory program execution and data read, other than verify, are disabled.)

Note: \*1 Always fix the level by pulling down or pulling up the mode pins (MD2 to MD0) up to powering off, except for mode switching.  
 \*2 See 21.2.6 Flash Memory Characteristics.

**Figure 18.26 Powering On/Off Timing (User Program Mode)**



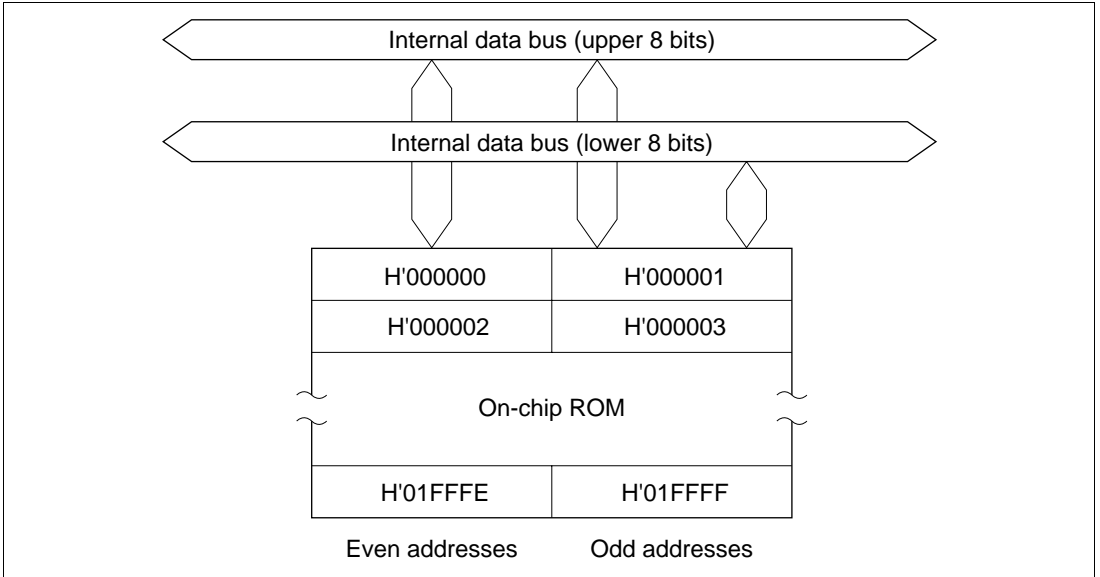


**Figure 18.27 Mode Transition Timing**  
**(Example: Boot mode → User mode ↔ User program mode)**

## 18.10 Mask ROM Overview

### 18.10.1 Block Diagram

Figure 18.28 shows a block diagram of the ROM.

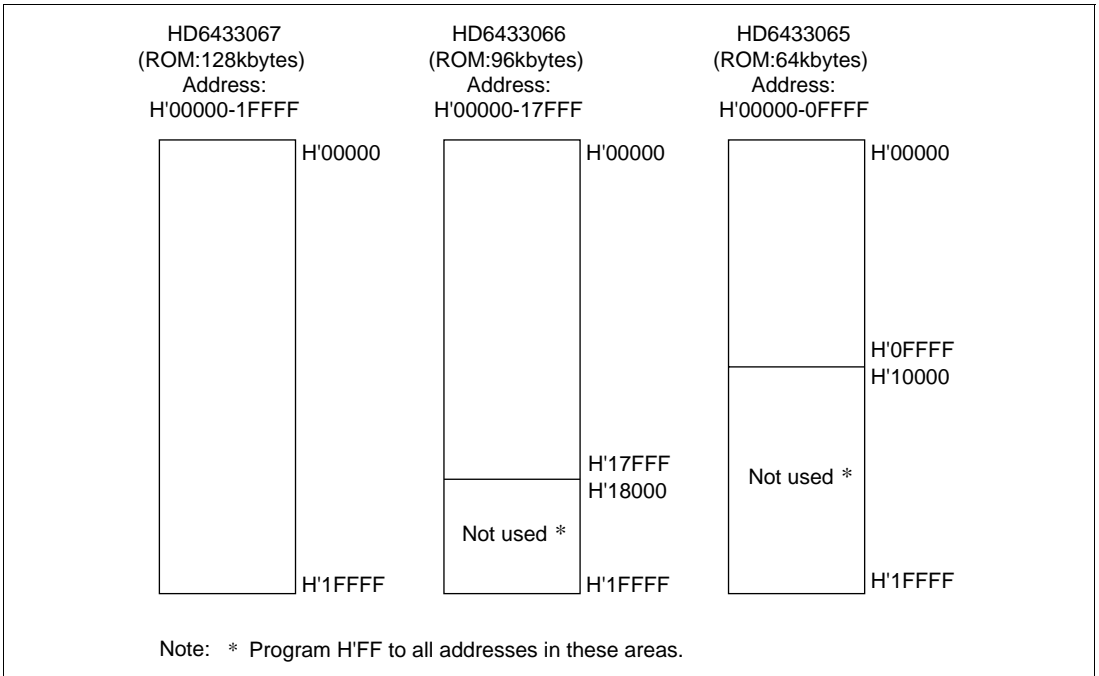


**Figure 18.28 ROM Block Diagram (H8/3067)**

## 18.11 Notes on Ordering Mask ROM Version Chip

When ordering the H8/3067 Series chips with a mask ROM, note the following.

- When ordering through an EPROM, use a 128-kbyte one.
- Fill all the unused addresses with H'FF as shown in figure 18.27 to make the ROM data size 128 kbytes for all H8/3067 Series chips, which incorporate different sizes of ROM. This applies to ordering through an EPROM and through electrical data transfer.
- The flash memory and flash memory R versions only registers for flash memory control (FLMCR, EBR, RAMCR, and FLMSR) are not provided in the mask ROM versions. Reading the corresponding addresses in a mask ROM version will always return 1s, and writes to these addresses are disabled. This must be borne in mind when switching from the flash memory and flash memory R versions to a mask ROM version.



**Figure 18.29 Mask ROM Addresses and Data**



# Section 19 Clock Pulse Generator

## 19.1 Overview

The H8/3067 Series has a built-in clock pulse generator (CPG) that generates the system clock ( $\phi$ ) and other internal clock signals ( $\phi/2$  to  $\phi/4096$ ). After duty adjustment, a frequency divider divides the clock frequency to generate the system clock ( $\phi$ ). The system clock is output at the  $\phi$  pin<sup>\*1</sup> and furnished as a master clock to prescalars that supply clock signals to the on-chip supporting modules. Frequency division ratios of 1/1, 1/2, 1/4, and 1/8 can be selected for the frequency divider by settings in a division control register (DIVCR)<sup>\*2</sup>. Power consumption in the chip is reduced in almost direct proportion to the frequency division ratio.

- Notes: 1. Usage of the  $\phi$  pin differs depending on the chip operating mode and the PSTOP bit setting in the module standby control register (MSTCR). For details, see section 20.7, System Clock Output Disabling Function.
2. The division ratio of the frequency divider can be changed dynamically during operation. The clock output at the  $\phi$  pin also changes when the division ratio is changed. The frequency output at the  $\phi$  pin is shown below.

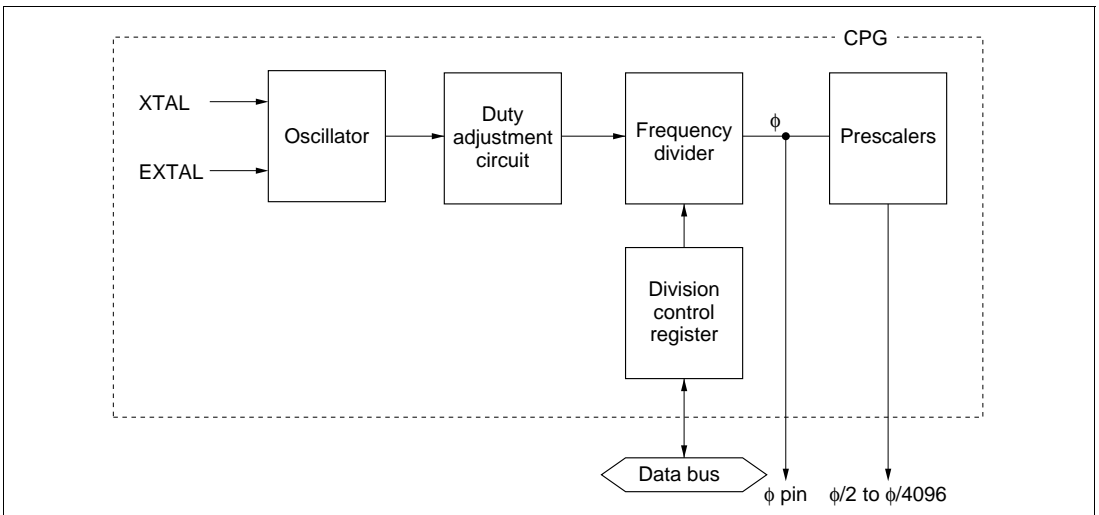
$$\phi = \text{EXTAL} \times n$$

where, EXTAL: Frequency of crystal resonator or external clock signal

n: Frequency division ratio (n = 1/1, 1/2, 1/4, or 1/8)

### 19.1.1 Block Diagram

Figure 19.1 shows a block diagram of the clock pulse generator.



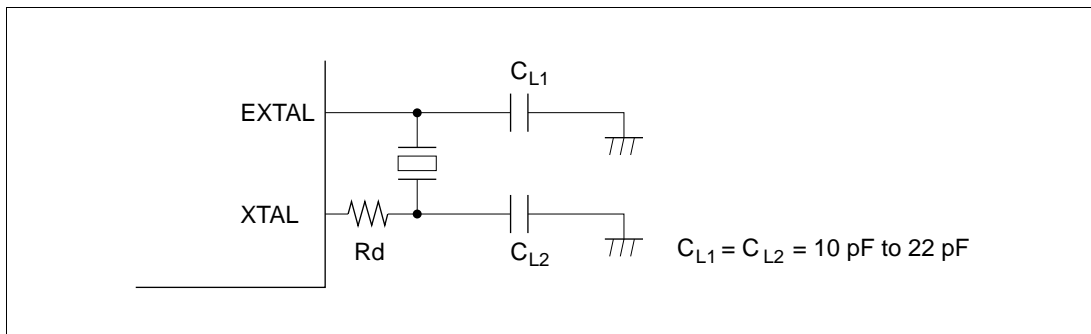
**Figure 19.1 Block Diagram of Clock Pulse Generator**

## 19.2 Oscillator Circuit

Clock pulses can be supplied by connecting a crystal resonator, or by input of an external clock signal.

### 19.2.1 Connecting a Crystal Resonator

**Circuit Configuration:** A crystal resonator can be connected as in the example in figure 19.2. The damping resistance  $R_d$  should be selected according to table 19.1. An AT-cut parallel-resonance crystal should be used.



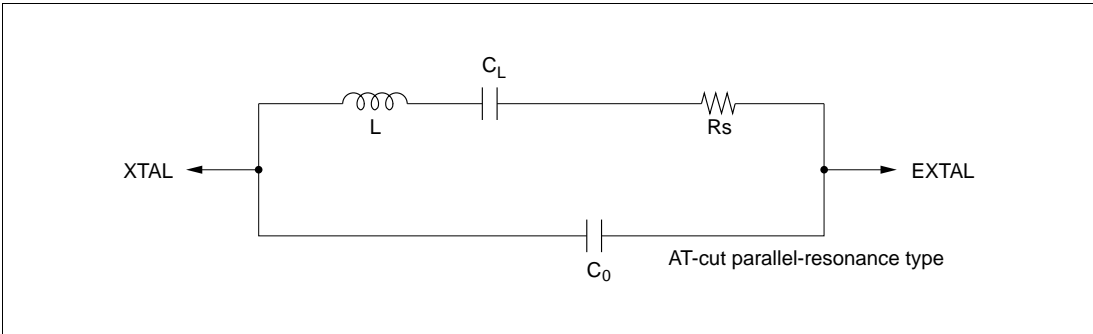
**Figure 19.2 Connection of Crystal Resonator (Example)**

**Table 19.1 Damping Resistance Value**

Damping Resistance Value	Frequency $f$ (MHz)														
	2	2 < $f$	4	4 < $f$	8	8 < $f$	10	10 < $f$	13	13 < $f$	16	16 < $f$	18	18 < $f$	20
$R_d$ ( )	1 k	500	200	0	0	0	0	0	0	0	0	0	0	0	0

Note: A crystal resonator between 2 MHz and 20 MHz can be used. If the chip is to be operated at less than 2 MHz, the on-chip frequency divider should be used. (A crystal resonator of less than 2 MHz cannot be used.)

**Crystal Resonator:** Figure 19.3 shows an equivalent circuit of the crystal resonator. The crystal resonator should have the characteristics listed in table 19.2.



**Figure 19.3 Crystal Resonator Equivalent Circuit**

**Table 19.2 Crystal Resonator Parameters**

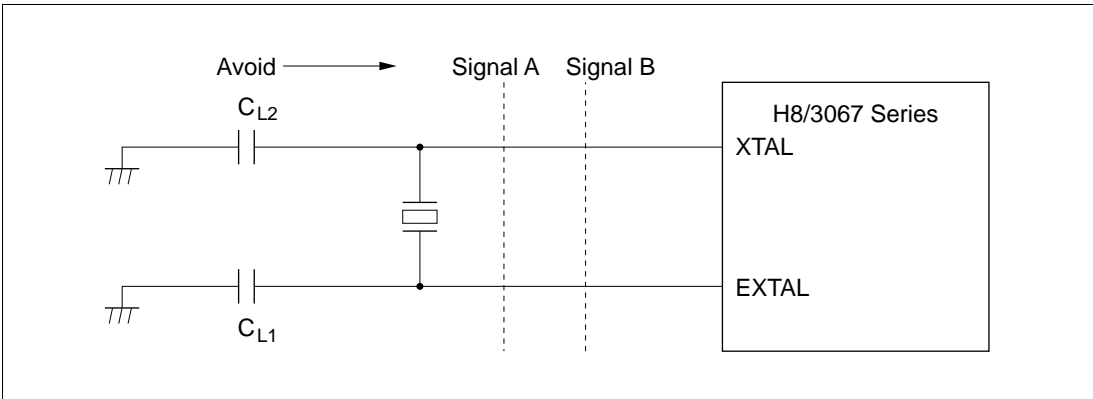
Frequency (MHz)	2	4	8	10	12	16	18	20
Rs max ( )	500	120	80	70	60	50	40	40
Co (pF)	7 pF max							

Use a crystal resonator with a frequency equal to the system clock frequency ( $\phi$ ).

**Notes on Board Design:** When a crystal resonator is connected, the following points should be noted:

Other signal lines should be routed away from the oscillator circuit to prevent induction from interfering with correct oscillation. See figure 19.4.

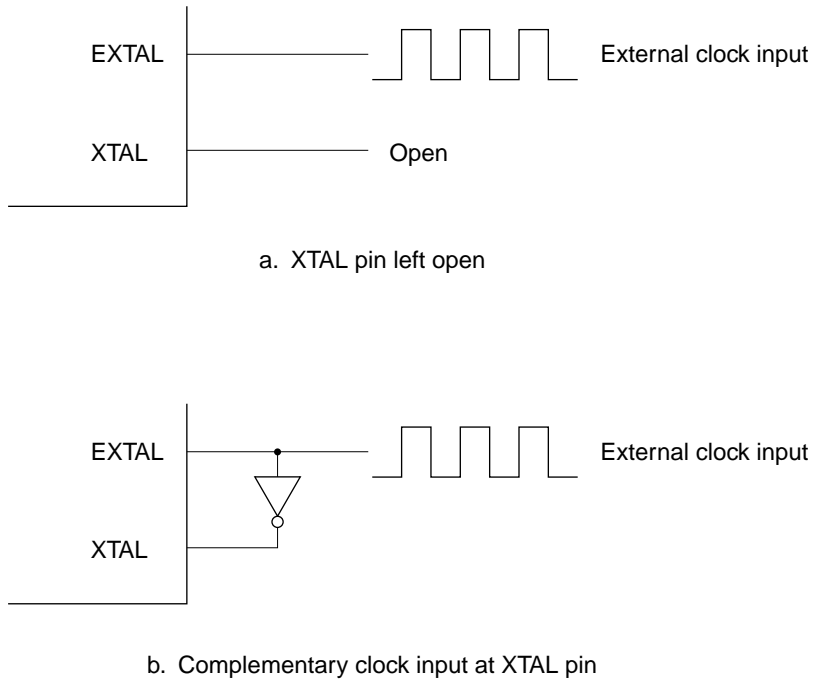
When the board is designed, the crystal resonator and its load capacitors should be placed as close as possible to the XTAL and EXTAL pins.



**Figure 19.4 Example of Incorrect Board Design**

## 19.2.2 External Clock Input

**Circuit Configuration:** An external clock signal can be input as shown in the examples in figure 19.5. If the XTAL pin is left open, the stray capacitance should not exceed 10 pF. If the stray capacitance at the XTAL pin exceeds 10 pF in configuration a, use configuration b instead and hold the clock high in standby mode.



**Figure 19.5 External Clock Input (Examples)**



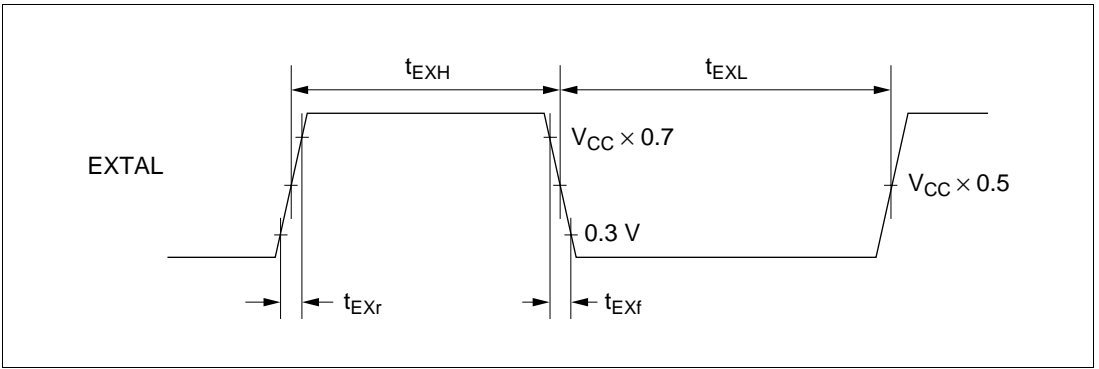
**External Clock:** The external clock frequency should be equal to the system clock frequency when not divided by the on-chip frequency divider. Table 19.3 shows the clock timing, figure 19.6 shows the external clock input timing, and figure 19.7 shows the external clock output settling delay timing. When the appropriate external clock is input via the EXTAL pin, its waveform is corrected by the on-chip oscillator and duty adjustment circuit.

When the appropriate external clock is input via the EXTAL pin, its waveform is corrected by the on-chip oscillator and duty adjustment circuit. The resulting stable clock is output to external devices after the external clock settling time ( $t_{\text{DEXT}}$ ) has passed after the clock input. The system must remain reset with the reset signal low during  $t_{\text{DEXT}}$ , while the clock output is unstable.

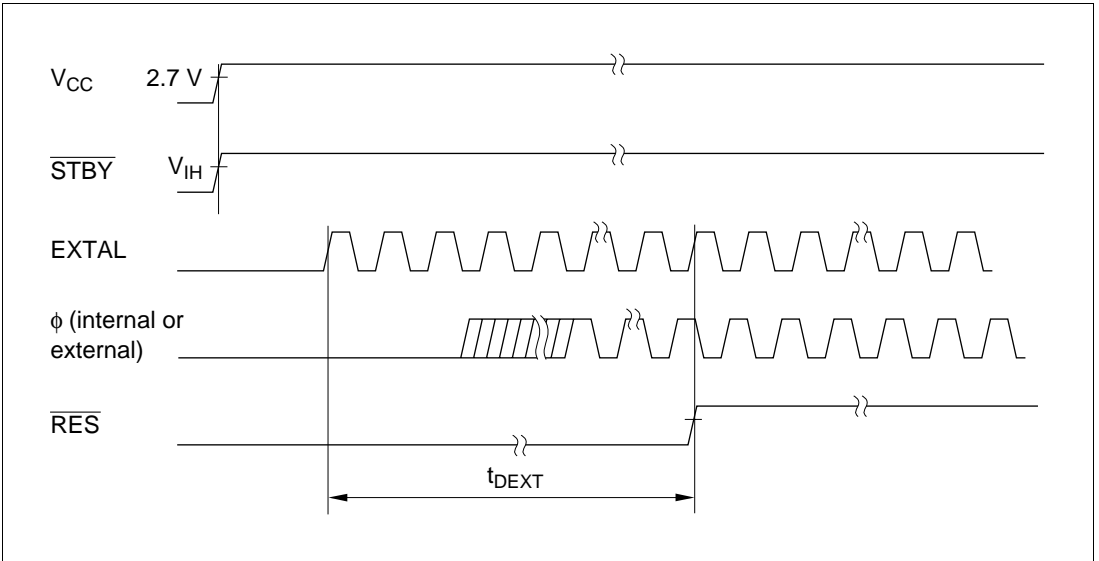
**Table 19.3 Clock Timing**

Item	Symbol	$V_{\text{CC}} = 2.7 \text{ V}$ to $5.5 \text{ V}^{*2}$		$V_{\text{CC}} = 3.0 \text{ V}$ to $5.5 \text{ V}$		$V_{\text{CC}} = 5.0 \text{ V} \pm$ 10%		Unit	Test Conditions	
		Min	Max	Min	Max	Min	Max			
External clock input low pulse width	$t_{\text{EXL}}$	40	$\tilde{N}$	30	$\tilde{N}$	15	$\tilde{N}$	ns	Figure 19.6	
External clock input high pulse width	$t_{\text{EXH}}$	40	$\tilde{N}$	30	$\tilde{N}$	15	$\tilde{N}$	ns		
External clock rise time	$t_{\text{EXr}}$	$\tilde{N}$	10	$\tilde{N}$	8	$\tilde{N}$	5	ns		
External clock fall time	$t_{\text{EXf}}$	$\tilde{N}$	10	$\tilde{N}$	8	$\tilde{N}$	5	ns		
Clock low pulse width	$t_{\text{CL}}$	0.4	0.6	0.4	0.6	0.4	0.6	$t_{\text{cyc}}$	$\phi$ 5 MHz	Figure 21.11
		80	$\tilde{N}$	80	$\tilde{N}$	80	$\tilde{N}$	ns	$\phi < 5 \text{ MHz}$	
Clock high pulse width	$t_{\text{CH}}$	0.4	0.6	0.4	0.6	0.4	0.6	$t_{\text{cyc}}$	$\phi$ 5 MHz	
		80	$\tilde{N}$	80	$\tilde{N}$	80	$\tilde{N}$	ns	$\phi < 5 \text{ MHz}$	
External clock output settling delay time	$t_{\text{DEXT}}^{*1}$	500	$\tilde{N}$	500	$\tilde{N}$	500	$\tilde{N}$	$\mu\text{s}$	Figure 19.7	

- Notes: 1.  $t_{\text{DEXT}}$  includes  $\overline{\text{RES}}$  pulse width ( $t_{\text{RESW}}$ ).  
 $t_{\text{RESW}}$  is 10  $t_{\text{cyc}}$  in the mask ROM version, and 20  $t_{\text{cyc}}$  in the flash memory and flash memory R versions.
2. The operating range  $\hat{O}V_{\text{CC}} = 2.7 \text{ V}$  to  $5.5 \text{ V}$  applies to the mask ROM version.



**Figure 19.6 External Clock Input Timing**



**Figure 19.7 External Clock Output Settling Delay Timing**

## 19.3 Duty Adjustment Circuit

When the oscillator frequency is 5 MHz or higher, the duty adjustment circuit adjusts the duty cycle of the clock signal from the oscillator to generate  $\phi$ .

## 19.4 Prescalers

The prescalers divide the system clock ( $\phi$ ) to generate internal clocks ( $\phi/2$  to  $\phi/4096$ ).

## 19.5 Frequency Divider

The frequency divider divides the duty-adjusted clock signal to generate the system clock ( $\phi$ ). The frequency division ratio can be changed dynamically by modifying the value in DIVCR, as described below. Power consumption in the chip is reduced in almost direct proportion to the frequency division ratio. The system clock generated by the frequency divider can be output at the  $\phi$  pin.

### 19.5.1 Register Configuration

Table 19.4 summarizes the frequency division register.

**Table 19.4 Frequency Division Register**

Address*	Name	Abbreviation	R/W	Initial Value
H'EE01B	Division control register	DIVCR	R/W	H'FC

Note: \* Lower 20 bits of the address in advanced mode.

### 19.5.2 Division Control Register (DIVCR)

DIVCR is an 8-bit readable/writable register that selects the division ratio of the frequency divider.

Bit	7	6	5	4	3	2	1	0
	$\bar{N}$	$\bar{N}$	$\bar{N}$	$\bar{N}$	$\bar{N}$	$\bar{N}$	DIV1	DIV0
Initial value	1	1	1	1	1	1	0	0
Read/Write	$\bar{N}$	$\bar{N}$	$\bar{N}$	$\bar{N}$	$\bar{N}$	$\bar{N}$	R/W	R/W

Reserved bits

**Divide bits 1 and 0**  
 These bits select the frequency division ratio

DIVCR is initialized to H'FC by a reset and in hardware standby mode. It is not initialized in software standby mode.

**Bits 7 to 2—Reserved:** These bits cannot be modified and are always read as 1.

**Bits 1 and 0—Divide (DIV1 and DIV0):** These bits select the frequency division ratio, as follows.

Bit 1 DIV1	Bit 0 DIV0	Frequency Division Ratio	
0	0	1/1	(Initial value)
0	1	1/2	
1	0	1/4	
1	1	1/8	

### 19.5.3 Usage Notes

The DIVCR setting changes the  $\phi$  frequency, so note the following points.

- Select a frequency division ratio that stays within the assured operation range specified for the clock cycle time  $t_{cyc}$  in the AC electrical characteristics. Note that  $\phi_{min} = 1$  MHz. Avoid settings that give system clock frequencies less than 1 MHz.
- All on-chip module operations are based on  $\phi$ . Note that the timing of timer operations, serial communication, and other time-dependent processing differs before and after any change in the division ratio. The waiting time for exit from software standby mode also changes when the division ratio is changed. For details, see section 20.4.3, Selection of Waiting Time for Exit from Software Standby Mode.

# Section 20 Power-Down State

## 20.1 Overview

The H8/3067 Series has a power-down state that greatly reduces power consumption by halting the CPU, and a module standby function that reduces power consumption by selectively halting on-chip modules.

The power-down state includes the following three modes:

- Sleep mode
- Software standby mode
- Hardware standby mode

The module standby function can halt on-chip supporting modules independently of the power-down state. The modules that can be halted are the 16-bit timer, 8-bit timer, SCI0, SCI1, SCI2, DMAC, DRAM interface, and A/D converter.

Table 20.1 indicates the methods of entering and exiting the power-down modes and module standby mode, and gives the status of the CPU and on-chip supporting modules in each mode.

**Table 20.1 Power-Down State and Module Standby Function**

State

Mode	State											Exiting Conditions				
	Entering Conditions	Clock	CPU Registers	CPU	DRAM Interface	16-Bit Timer	8-Bit Timer	SC10	SC11	SC12	A/D		Other Modules RAM	$\phi$ clock output*4	I/O Ports	
Sleep mode	SLEEP instruc- tion executed while SSBY = 0 in SYSCR	Active	Halted	Held	Active	Active	Active	Active	Active	Active	Active	Active	Held	$\phi$ output	Held	<ul style="list-style-type: none"> <li>Interrupt</li> <li>RES</li> <li>STBY</li> </ul>
Software standby mode	SLEEP instruc- tion executed while SSBY = 1 in SYSCR	Halted	Halted	Halted	Halted	Halted	Halted	Halted	Halted	Halted	Halted	Halted	Held	High output	Held	<ul style="list-style-type: none"> <li>NMI</li> <li>IRQ<sub>0</sub> to IRQ<sub>2</sub></li> <li>RES</li> <li>STBY</li> </ul>
Hardware standby mode	Low input at STBY pin	Halted	Halted	Undeter- mined	Halted	Halted	Halted	Halted	Halted	Halted	Halted	Halted	Held	High impedance	High impedance	<ul style="list-style-type: none"> <li>STBY</li> <li>RES</li> <li>Clear MStCR bit to 0*5</li> </ul>
Module standby	Corresponding bit set to 1 in MStCR	Active	Active	—	Halted*2	Halted*2	Halted*2	Halted*2	Halted*2	Halted*2	Halted*2	Halted*2	Active	High impedance*2	—	<ul style="list-style-type: none"> <li>STBY</li> <li>RES</li> <li>Clear MStCR bit to 0*5</li> </ul>

Notes: 1. RTCNT and bits 7 and 6 of RTMCSR are initialized. Other bits and registers hold their previous states.

2. State in which the corresponding MStCR bit was set to 1. For details see section 20.2.2, Module Standby Control Register H (MStCRH) and section 20.2.3, Module Standby Control Register L (MStCRL).

3. The RAME bit must be cleared to 0 in SYSCR before the transition from the program execution state to hardware standby mode.

4. When P6<sub>7</sub> is used as the  $\phi$  output pin.

5. When a MStCR bit is set to 1, the registers of the corresponding on-chip supporting module are initialized. To restart the module, first clear the MStCR bit to 0, then set up the module registers again.

Legend

SYSCR: System control register

SSBY: Software standby bit

MStCRH: Module standby control register H

MStCRL: Module standby control register L

## 20.2 Register Configuration

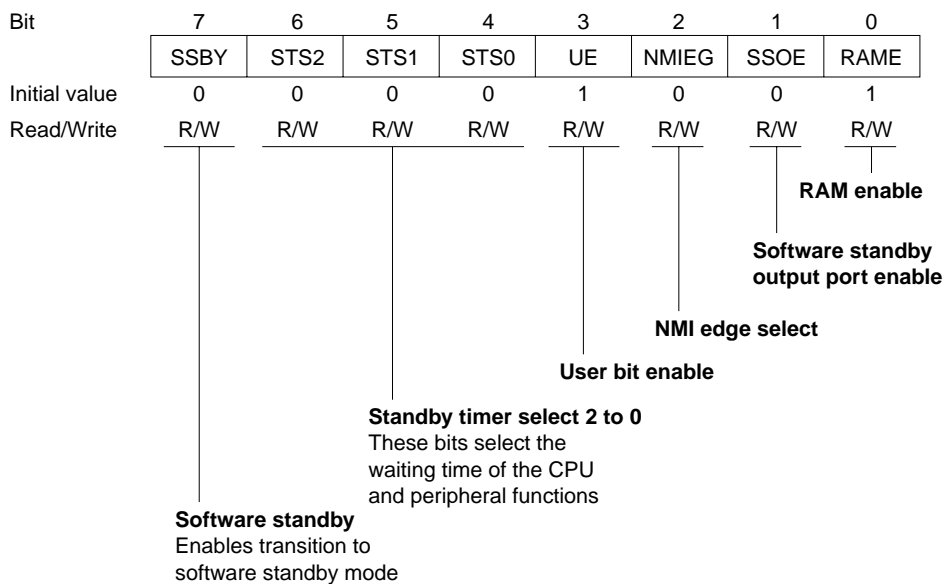
The H8/3067 Series has a system control register (SYSCR) that controls the power-down state, and module standby control registers H (MSTCRH) and L (MSTCRL) that control the module standby function. Table 20.2 summarizes these registers.

**Table 20.2 Control Register**

Address*	Name	Abbreviation	R/W	Initial Value
H'EE012	System control register	SYSCR	R/W	H'09
H'EE01C	Module standby control register H	MSTCRH	R/W	H'78
H'EE01D	Module standby control register L	MSTCRL	R/W	H'00

Note: \* Lower 20 bits of the address in advanced mode.

### 20.2.1 System Control Register (SYSCR)



SYSCR is an 8-bit readable/writable register. Bit 7 (SSBY), bits 6 to 4 (STS2 to STS0), and bit 1 (SSOE) control the power-down state. For information on the other SYSCR bits, see section 3.3, System Control Register (SYSCR).

**Bit 7—Software Standby (SSBY):** Enables transition to software standby mode. When software standby mode is exited by an external interrupt, this bit remains set to 1 after the return to normal operation. To clear this bit, write 0.

**Bit 7**

SSBY	Description	
0	SLEEP instruction causes transition to sleep mode	(Initial value)
1	SLEEP instruction causes transition to software standby mode	

**Bits 6 to 4—Standby Timer Select (STS2 to STS0):** These bits select the length of time the CPU and on-chip supporting modules wait for the clock to settle when software standby mode is exited by an external interrupt. If the clock is generated by a crystal resonator, set these bits according to the clock frequency so that the waiting time will be at least 7 ms (oscillation settling time). See table 20.3. If an external clock is used, any setting is permitted.

Bit 6 STS2	Bit 5 STS1	Bit 4 STS0	Description	
0	0	0	Waiting time = 8,192 states	(Initial value)
		1	Waiting time = 16,384 states	
	1	0	Waiting time = 32,768 states	
		1	Waiting time = 65,536 states	
1	0	0	Waiting time = 131,072 states	
		1	Waiting time = 262,144 states	
	1	0	Waiting time = 1,024 states	
		1	Illegal setting	

**Bit 1—Software Standby Output Port Enable (SSOE):** Specifies whether the address bus and bus control signals ( $\overline{CS}_0$  to  $\overline{CS}_7$ ,  $\overline{AS}$ ,  $\overline{RD}$ ,  $\overline{HWR}$ ,  $\overline{LWR}$ ,  $\overline{UCAS}$ ,  $\overline{LCAS}$ , and  $\overline{RFSH}$ ) are kept as outputs or fixed high, or placed in the high-impedance state in software standby mode.

**Bit 1**

SSOE	Description	
0	In software standby mode, the address bus and bus control signals are all high-impedance	(Initial value)
1	In software standby mode, the address bus retains its output state and bus control signals are fixed high	



## 20.2.2 Module Standby Control Register H (MSTCRH)

MSTCRH is an 8-bit readable/writable register that controls output of the system clock ( $\phi$ ). It also controls the module standby function, which places individual on-chip supporting modules in the standby state. Module standby can be designated for the SCI0, SCI1, SCI2.

Bit	7	6	5	4	3	2	1	0
	PSTOP	—	—	—	—	MSTPH2	MSTPH1	MSTPH0
Initial value	0	1	1	1	1	0	0	0
Read/Write	R/W	—	—	—	—	R/W	R/W	R/W

Reserved bit
Module standby H2 to 0  
These bits select modules to be placed in standby

$\phi$  clock stop  
 Enables or disables output of the system clock

MSTCRH is initialized to H'78 by a reset and in hardware standby mode. It is not initialized in software standby mode.

**Bit 7— $\phi$  Clock Stop (PSTOP):** Enables or disables output of the system clock ( $\phi$ ).

### Bit 1

#### PSTOP

#### Description

0	System clock output is enabled	(Initial value)
1	System clock output is disabled	

**Bits 6 to 3—Reserved:** These bits cannot be modified and are always read as 1.

**Bit 2—Module Standby H2 (MSTPH2):** Selects whether to place the SCI2 in standby.

### Bit 2

#### MSTPH2

#### Description

0	SCI2 operates normally	(Initial value)
1	SCI2 is in standby state	

**Bit 1—Module Standby H1 (MSTPH1):** Selects whether to place the SCI1 in standby.

**Bit 1**

MSTPH1	Description	
0	SCI1 operates normally	(Initial value)
1	SCI1 is in standby state	

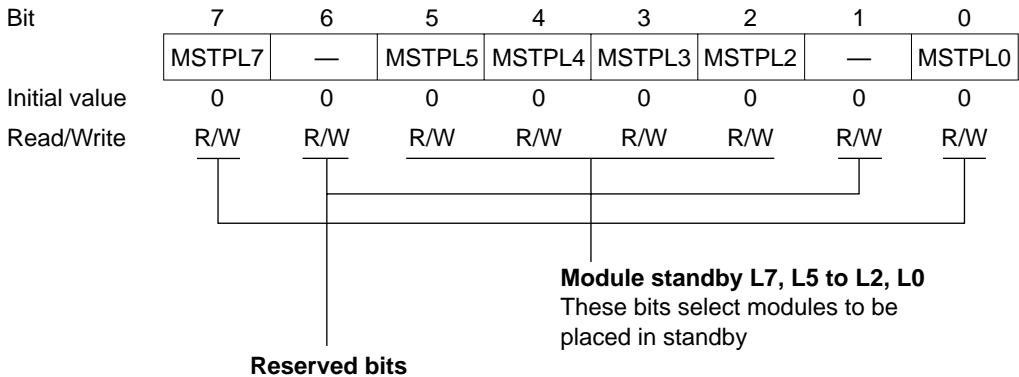
**Bit 0—Module Standby H0 (MSTPH0):** Selects whether to place the SCI0 in standby.

**Bit 0**

MSTPH0	Description	
0	SCI0 operates normally	(Initial value)
1	SCI0 is in standby state	

### 20.2.3 Module Standby Control Register L (MSTCRL)

MSTCRL is an 8-bit readable/writable register that controls the module standby function, which places individual on-chip supporting modules in the standby state. Module standby can be designated for the DMAC, 16-bit timer, DRAM interface, 8-bit timer, and A/D converter modules.



MSTCRL is initialized to H'00 by a reset and in hardware standby mode. It is not initialized in software standby mode.

**Bit 7—Module Standby L7 (MSTPL7):** Selects whether to place the DMAC in standby.

**Bit 7**

MSTPL7	Description	
0	DMAC operates normally	(Initial value)
1	DMAC is in standby state	

**Bit 6—Reserved:** This bit can be written and read.

**Bit 5—Module Standby L5 (MSTPL5):** Selects whether to place the DRAM interface in standby.

**Bit 5**

<b>MSTPL5</b>	<b>Description</b>	
0	DRAM interface operates normally	(Initial value)
1	DRAM interface is in standby state	

**Bit 4—Module Standby L4 (MSTPL4):** Selects whether to place the 16-bit timer in standby.

**Bit 4**

<b>MSTPL4</b>	<b>Description</b>	
0	16-bit timer operates normally	(Initial value)
1	16-bit timer is in standby state	

**Bit 3—Module Standby L3 (MSTPL3):** Selects whether to place 8-bit timer channels 0 and 1 in standby.

**Bit 3**

<b>MSTPL3</b>	<b>Description</b>	
0	8-bit timer channels 0 and 1 operate normally	(Initial value)
1	8-bit timer channels 0 and 1 are in standby state	

**Bit 2—Module Standby L2 (MSTPL2):** Selects whether to place 8-bit timer channels 2 and 3 in standby.

**Bit 2**

<b>MSTPL2</b>	<b>Description</b>	
0	8-bit timer channels 2 and 3 operate normally	(Initial value)
1	8-bit timer channels 2 and 3 are in standby state	

**Bit 1—Reserved:** This bit can be written and read.

**Bit 0—Module Standby L0 (MSTPL0):** Selects whether to place the A/D converter in standby.

**Bit 0**

<b>MSTPL0</b>	<b>Description</b>	
0	A/D converter operates normally	(Initial value)
1	A/D converter is in standby state	

## 20.3 Sleep Mode

### 20.3.1 Transition to Sleep Mode

When the SSBY bit is cleared to 0 in SYSCR, execution of the SLEEP instruction causes a transition from the program execution state to sleep mode. Immediately after executing the SLEEP instruction the CPU halts, but the contents of its internal registers are retained. The DMA controller (DMAC), DRAM interface, and on-chip supporting modules do not halt in sleep mode. Modules which have been placed in standby by the module standby function, however, remain halted.

### 20.3.2 Exit from Sleep Mode

Sleep mode is exited by an interrupt, or by input at the  $\overline{\text{RES}}$  or  $\overline{\text{STBY}}$  pin.

**Exit by Interrupt:** An interrupt terminates sleep mode and causes a transition to the interrupt exception handling state. Sleep mode is not exited by an interrupt source in an on-chip supporting module if the interrupt is disabled in the on-chip supporting module. Sleep mode is not exited by an interrupt other than NMI if the interrupt is masked by interrupt priority settings and the settings of the I and UI bits in CCR, IPR.

**Exit by  $\overline{\text{RES}}$  Input:** Low input at the  $\overline{\text{RES}}$  pin exits from sleep mode to the reset state.

**Exit by  $\overline{\text{STBY}}$  Input:** Low input at the  $\overline{\text{STBY}}$  pin exits from sleep mode to hardware standby mode.

## 20.4 Software Standby Mode

### 20.4.1 Transition to Software Standby Mode

To enter software standby mode, execute the SLEEP instruction while the SSBY bit is set to 1 in SYSCR.

In software standby mode, current dissipation is reduced to an extremely low level because the CPU, clock, and on-chip supporting modules all halt. The DMAC and on-chip supporting modules are reset and halted. As long as the specified voltage is supplied, however, CPU register contents and on-chip RAM data are retained. The settings of the I/O ports and DRAM interface\* are also held. When the WDT is used as a watchdog timer ( $WT/\overline{IT} = 1$ ), the TME bit must be cleared to 0 before setting SSBY. Also, when setting TME to 1, SSBY should be cleared to 0.

Clear the BRLE bit in BRCCR (inhibiting bus release) before making a transition to software standby mode.

Note: \* RTCNT and bits 7 and 6 of RTMCSR are initialized. Other bits and registers hold their previous states.

### 20.4.2 Exit from Software Standby Mode

Software standby mode can be exited by input of an external interrupt at the NMI,  $\overline{IRQ_0}$ ,  $\overline{IRQ_1}$ , or  $\overline{IRQ_2}$  pin, or by input at the  $\overline{RES}$  or  $\overline{STBY}$  pin.

**Exit by Interrupt:** When an NMI,  $IRQ_0$ ,  $IRQ_1$ , or  $IRQ_2$  interrupt request signal is received, the clock oscillator begins operating. After the oscillator settling time selected by bits STS2 to STS0 in SYSCR, stable clock signals are supplied to the entire chip, software standby mode ends, and interrupt exception handling begins. Software standby mode is not exited if the interrupt enable bits of interrupts  $IRQ_0$ ,  $IRQ_1$ , and  $IRQ_2$  are cleared to 0, or if these interrupts are masked in the CPU.

**Exit by  $\overline{RES}$  Input:** When the  $\overline{RES}$  input goes low, the clock oscillator starts and clock pulses are supplied immediately to the entire chip. The  $\overline{RES}$  signal must be held low long enough for the clock oscillator to stabilize. When  $\overline{RES}$  goes high, the CPU starts reset exception handling.

**Exit by  $\overline{STBY}$  Input:** Low input at the  $\overline{STBY}$  pin causes a transition to hardware standby mode.

### 20.4.3 Selection of Waiting Time for Exit from Software Standby Mode

Bits STS2 to STS0 in SYSCR and bits DIV1 and DIV0 in DIVCR should be set as follows.

**Crystal Resonator:** Set STS2 to STS0, DIV1, and DIV0 so that the waiting time (for the clock to stabilize) is at least 7 ms. Table 20.3 indicates the waiting times that are selected by STS2 to STS0, DIV1, and DIV0 settings at various system clock frequencies.

**External Clock:** Any values may be set.

**Table 20.3 Clock Frequency and Waiting Time for Clock to Settle**

DIV1	DIV0	STS2	STS1	STS0	Waiting Time	20 MHz	18 MHz	16 MHz	12 MHz	10 MHz	8 MHz	6 MHz	4 MHz	2 MHz	1 MHz	Unit
0	0	0	0	0	8192 states	0.4	0.46	0.51	0.65	0.8	1.0	1.3	2.0	4.1	8.2*	ms
		0	0	1	16384 states	0.8	0.91	1.0	1.3	1.6	2.0	2.7	4.1	8.2*	16.4	
		0	1	0	32768 states	1.6	1.8	2.0	2.7	3.3	4.1	5.5	8.2*	16.4	32.8	
		0	1	1	65536 states	3.3	3.6	4.1	5.5	6.6	8.2*	10.9*	16.4	32.8	65.5	
		1	0	0	131072 states	6.6	7.3*	8.2*	10.9*	13.1*	16.4	21.8	32.8	65.5	131.1	
		1	0	1	262144 states	13.1*	14.6	16.4	21.8	26.2	32.8	43.7	65.5	131.1	262.1	
		1	1	0	1024 states	0.05	0.057	0.064	0.085	0.10	0.13	0.17	0.26	0.51	1.0	
		1	1	1							Illegal setting					
0	1	0	0	0	8192 states	0.8	0.91	1.02	1.4	1.6	2.0	2.7	4.0	8.2*	16.4*	ms
		0	0	1	16384 states	1.6	1.8	2.0	2.7	3.3	4.1	5.5	8.2*	16.4	32.8	
		0	1	0	32768 states	3.3	3.6	4.1	5.5	6.6	8.2*	10.9*	16.4	32.8	65.5	
		0	1	1	65536 states	6.6	7.3*	8.2*	10.9*	13.1*	16.4	21.8	32.8	65.5	131.1	
		1	0	0	131072 states	13.1*	14.6	16.4	21.8	26.2	32.8	43.7	65.5	131.1	262.1	
		1	0	1	262144 states	26.2	29.1	32.8	43.7	52.4	65.5	87.4	131.1	262.1	524.3	
		1	1	0	1024 states	0.10	0.11	0.13	0.17	0.20	0.26	0.34	0.51	1.0	2.0	
		1	1	1							Illegal setting					
1	0	0	0	0	8192 states	1.6	1.8	2.0	2.7	3.3	4.1	5.5	8.2*	16.4*	32.8*	ms
		0	0	1	16384 states	3.3	3.6	4.1	5.5	6.6	8.2*	10.9*	16.4	32.8	65.5	
		0	1	0	32768 states	6.6	7.3*	8.2*	10.9*	13.1*	16.4	21.8	32.8	65.5	131.1	
		0	1	1	65536 states	13.1*	14.6	16.4	21.8	26.2	32.8	43.7	65.5	131.1	262.1	
		1	0	0	131072 states	26.2	29.1	32.8	43.7	52.4	65.5	87.4	131.1	262.1	524.3	
		1	0	1	262144 states	52.4	58.3	65.5	87.4	104.9	131.1	174.8	262.1	524.3	1048.6	
		1	1	0	1024 states	0.20	0.23	0.26	0.34	0.41	0.51	0.68	1.02	2.0	4.1	
		1	1	1							Illegal setting					
1	1	0	0	0	8192 states	3.3	3.6	4.1	5.5	6.6	8.2*	10.9*	16.4*	32.8*	65.5	ms
		0	0	1	16384 states	6.6	7.3*	8.2*	10.9*	13.1*	16.4	21.8	32.8	65.5	131.1	
		0	1	0	32768 states	13.1*	14.6	16.4	21.8	26.2	32.8	43.7	65.5	131.1	262.1	
		0	1	1	65536 states	26.2	29.1	32.8	43.7	52.4	65.5	87.4	131.1	262.1	524.3	
		1	0	0	131072 states	52.4	58.3	65.5	87.4	104.9	131.1	174.8	262.1	524.3	1048.6	
		1	0	1	262144 states	104.9	116.5	131.1	174.8	209.7	262.1	349.5	524.3	1048.6	2097.1	
		1	1	0	1024 states	0.41	0.46	0.51	0.68	0.82	1.0	1.4	2.0	4.1	8.2*	
		1	1	1							Illegal setting					

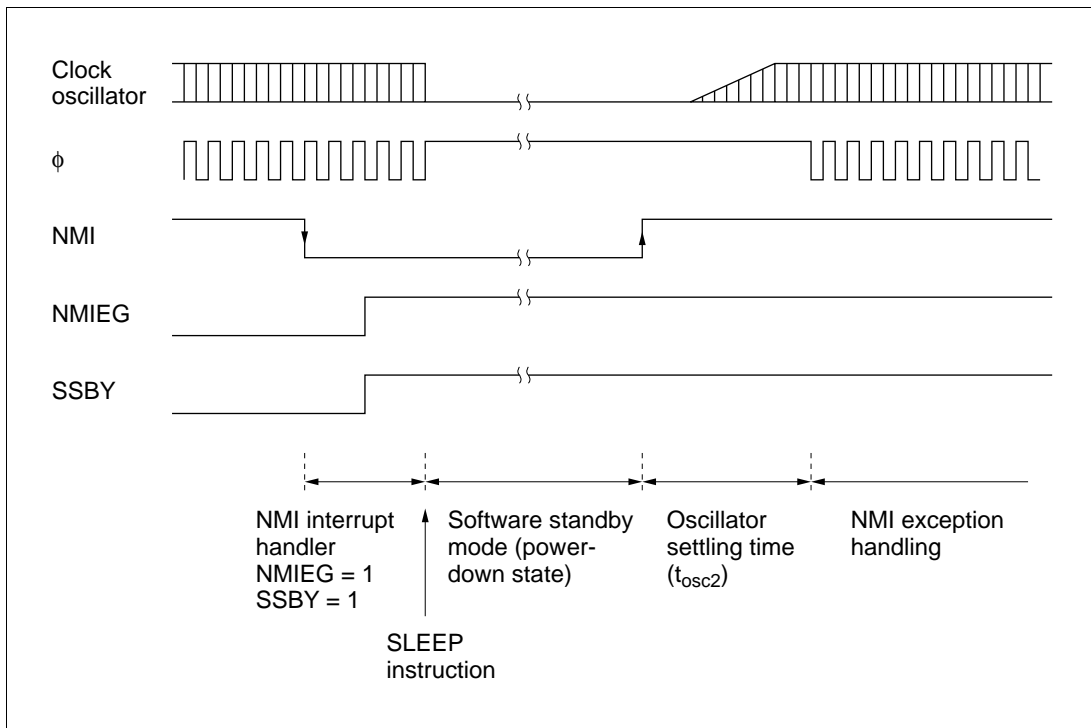
\*: Recommended setting

## 20.4.4 Sample Application of Software Standby Mode

Figure 20.1 shows an example in which software standby mode is entered at the fall of NMI and exited at the rise of NMI.

With the NMI edge select bit (NMIEG) cleared to 0 in SYSCR (selecting the falling edge), an NMI interrupt occurs. Next the NMIEG bit is set to 1 (selecting the rising edge) and the SSBY bit is set to 1; then the SLEEP instruction is executed to enter software standby mode.

Software standby mode is exited at the next rising edge of the NMI signal.



**Figure 20.1 NMI Timing for Software Standby Mode (Example)**

## 20.4.5 Note

The I/O ports retain their existing states in software standby mode. If a port is in the high output state, its output current is not reduced.

## 20.4.6 Cautions on Clearing the Software Standby Mode of F-ZTAT Version

### (1) Operation phenomena

When using operating mode 5, 6, or 7\* (on-chip flash memory enabled), the first read of on-chip flash memory after exiting software standby mode may not be carried out correctly.

Software standby mode is exited by means of an external interrupt (via the NMI,  $\overline{\text{IRQ}}_0$ ,  $\overline{\text{IRQ}}_1$ , or  $\overline{\text{IRQ}}_2$  pin), the  $\overline{\text{RES}}$  pin, or the  $\overline{\text{STBY}}$  pin. In the case of an external interrupt via the NMI,  $\overline{\text{IRQ}}_0$ ,  $\overline{\text{IRQ}}_1$ , or  $\overline{\text{IRQ}}_2$  pin, the first read after exiting software standby mode is a read of the vector corresponding to the respective exception handling interrupt source. This vector may not be read correctly, resulting in program runaway.

Note: \* Mode 5: expanded 16-Mbyte mode with on-chip ROM enabled

Mode 6: single-chip normal mode

Mode 7: single-chip advanced mode

### (2) Exemplary procedures to avoid program runaway

This operation phenomenon can be avoided by writing or amending program code in accordance with the following procedures.

- (a) When using mode 5 or mode 7, assign addresses in the 64-kbyte space from H'00000 to H'0FFFF as the vector addresses for the external interrupts that clear software standby mode.
- (b) When using mode 6, change the mode to mode 7 in the program, and use change (a) above.

Note that it is necessary to change vector address assignments and to extend addresses as follows.

- Addresses H'DFFF and below (on-chip ROM area): H'xxxx → H'0xxxx
- Addresses H'E000 to H'E0FF (internal I/O registers-1): H'yyyy → H'Eyyyy
- Addresses H'EF20 and above (on-chip RAM area and internal I/O registers-2): H'zzzz → H'Fzzzz

(Where x, y and z are any hexadecimal numbers)

With the production lots prior to the week code “9K1” of the HD64F3067 and HD64F3067R, avoid program runaway according to the procedures designated above.

Meanwhile, as for the production lots of the week code “9K1” and after, the special constraint according to of the aforementioned Section (2) is not applicable.



## 20.5 Hardware Standby Mode

### 20.5.1 Transition to Hardware Standby Mode

Regardless of its current state, the chip enters hardware standby mode whenever the  $\overline{\text{STBY}}$  pin goes low. Hardware standby mode reduces power consumption drastically by halting all functions of the CPU, DMAC, DRAM interface, and on-chip supporting modules. All modules are reset except the on-chip RAM. As long as the specified voltage is supplied, on-chip RAM data is retained. I/O ports are placed in the high-impedance state.

Clear the RAME bit to 0 in SYSCR before  $\overline{\text{STBY}}$  goes low to retain on-chip RAM data.

The inputs at the mode pins (MD2 to MD0) should not be changed during hardware standby mode.

### 20.5.2 Exit from Hardware Standby Mode

Hardware standby mode is exited by inputs at the  $\overline{\text{STBY}}$  and  $\overline{\text{RES}}$  pins. While  $\overline{\text{RES}}$  is low, when  $\overline{\text{STBY}}$  goes high, the clock oscillator starts running.  $\overline{\text{RES}}$  should be held low long enough for the clock oscillator to settle. When  $\overline{\text{RES}}$  goes high, reset exception handling begins, followed by a transition to the program execution state.

### 20.5.3 Timing for Hardware Standby Mode

Figure 20.2 shows the timing relationships for hardware standby mode. To enter hardware standby mode, first drive  $\overline{\text{RES}}$  low, then drive  $\overline{\text{STBY}}$  low. To exit hardware standby mode, first drive  $\overline{\text{STBY}}$  high, wait for the clock to settle, then bring  $\overline{\text{RES}}$  from low to high.

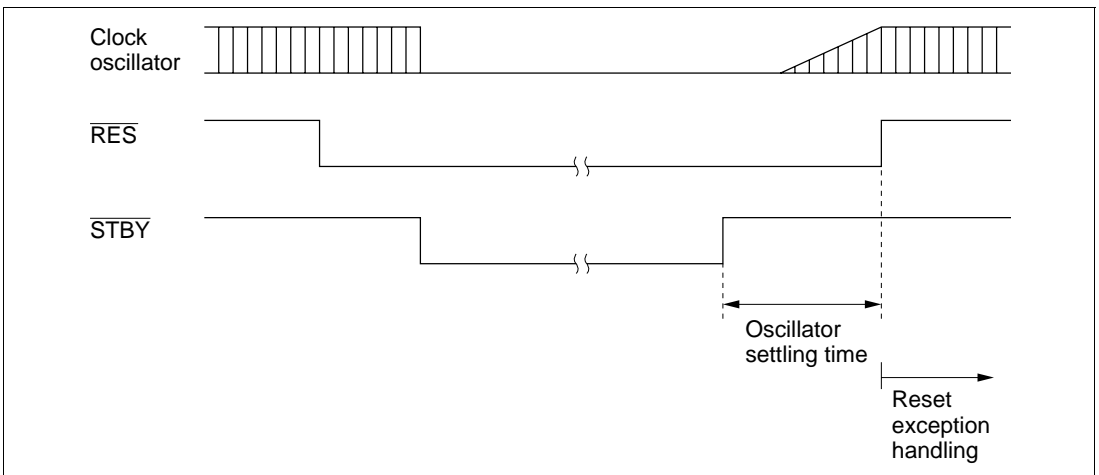


Figure 20.2 Hardware Standby Mode Timing

## 20.6 Module Standby Function

### 20.6.1 Module Standby Timing

The module standby function can halt several of the on-chip supporting modules (SCI2, SCI1, SCI0, the DMAC, 16-bit timer, 8-bit timer, DRAM interface, and A/D converter) independently in the power-down state. This standby function is controlled by bits MSTPH2 to MSTPH0 in MSTCRH and bits MSTPL7 to MSTPL0 in MSTCRL. When one of these bits is set to 1, the corresponding on-chip supporting module is placed in standby and halts at the beginning of the next bus cycle after the MSTCR write cycle.

### 20.6.2 Read/Write in Module Standby

When an on-chip supporting module is in module standby, read/write access to its registers is disabled. Read access always results in H'FF data. Write access is ignored.

### 20.6.3 Usage Notes

When using the module standby function, note the following points.

**DMAC:** When setting a bit in MSTCR to 1 to place the DMAC in module standby, make sure that the DMAC is not currently requesting the bus right. If the corresponding bit in MSTCR is set to 1 when a bus request is present, operation of the bus arbiter becomes ambiguous and a malfunction may occur.

**DRAM Interface:** When the module standby function is used on the DRAM interface, set the MSTCR bit to 1 while DRAM space is deselected.

**On-Chip Supporting Module Interrupts:** Before setting a module standby bit, first disable interrupts by that module. When an on-chip supporting module is placed in standby by the module standby function, its registers are initialized, including registers with interrupt request flags.

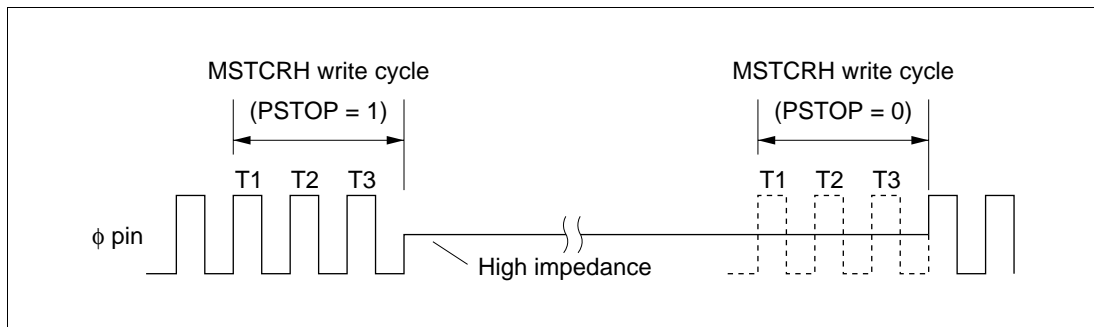
**Pin States:** Pins used by an on-chip supporting module lose their module functions when the module is placed in module standby. What happens after that depends on the particular pin. For details, see section 8, I/O Ports. Pins that change from the input to the output state require special care. For example, if SCI1 is placed in module standby, the receive data pin loses its receive data function and becomes a port pin. If its port DDR bit is set to 1, the pin becomes a data output pin, and its output may collide with external SCI transmit data. Data collision should be prevented by clearing the port DDR bit to 0 or taking other appropriate action.

**Register Resetting:** When an on-chip supporting module is halted by the module standby function, all its registers are initialized. To restart the module, after its MSTCR bit is cleared to 0, its registers must be set up again. It is not possible to write to the registers while the MSTCR bit is set to 1.

**MSTCR Access from DMAC Disabled:** To prevent malfunctions, MSTCR can only be accessed from the CPU. It can be read by the DMAC, but it cannot be written by the DMAC.

## 20.7 System Clock Output Disabling Function

Output of the system clock ( $\phi$ ) can be controlled by the PSTOP bit in MSTCRH. When the PSTOP bit is set to 1, output of the system clock halts and the  $\phi$  pin is placed in the high-impedance state. Figure 20.3 shows the timing of the stopping and starting of system clock output. When the PSTOP bit is cleared to 0, output of the system clock is enabled. Table 20.4 indicates the state of the  $\phi$  pin in various operating states.



**Figure 20.3 Starting and Stopping of System Clock Output**

**Table 20.4  $\phi$  Pin State in Various Operating States**

Operating State	PSTOP = 0	PSTOP = 1
Hardware standby	High impedance	High impedance
Software standby	Always high	High impedance
Sleep mode	System clock output	High impedance
Normal operation	System clock output	High impedance



# Section 21 Electrical Characteristics

## 21.1 Electrical Characteristics of Mask ROM Version

### 21.1.1 Absolute Maximum Ratings

Table 21.1 lists the absolute maximum ratings.

**Table 21.1 Absolute Maximum Ratings**

Item	Symbol	Value	Unit
Power supply voltage	$V_{CC}$	-0.3 to +7.0	V
Input voltage (except for port 7)	$V_{in}$	-0.3 to $V_{CC} + 0.3$	V
Input voltage (port 7)	$V_{in}$	-0.3 to $AV_{CC} + 0.3$	V
Reference voltage	$V_{REF}$	-0.3 to $AV_{CC} + 0.3$	V
Analog power supply voltage	$AV_{CC}$	-0.3 to +7.0	V
Analog input voltage	$V_{AN}$	-0.3 to $AV_{CC} + 0.3$	V
Operating temperature	$T_{opr}$	Regular specifications: -20 to +75	°C
		Wide-range specifications: -40 to +85	°C
Storage temperature	$T_{stg}$	-55 to +125	°C

Caution: Permanent damage to the chip may result if absolute maximum ratings are exceeded.

## 21.1.2 DC Characteristics

Table 21.2 lists the DC characteristics. Table 21.3 lists the permissible output currents.

**Table 21.2 DC Characteristics (1)**

Conditions:  $V_{CC} = 5.0\text{ V} \pm 10\%$ ,  $AV_{CC} = 5.0\text{ V} \pm 10\%$ ,  $V_{REF} = 4.5\text{ V}$  to  $AV_{CC}^{*1}$ ,  
 $V_{SS} = AV_{SS} = 0\text{ V}^{*1}$ ,  $T_a = -20^\circ\text{C}$  to  $+75^\circ\text{C}$  (regular specifications),  
 $T_a = -40^\circ\text{C}$  to  $+85^\circ\text{C}$  (wide-range specifications)

Item	Symbol	Min	Typ	Max	Unit	Test Conditions	
Schmitt trigger input voltages	Port A, P8 <sub>0</sub> to P8 <sub>2</sub>	$V_T^-$	1.0	—	—	V	
		$V_T^+$	—	—	$V_{CC} \times 0.7$	V	
		$V_T^+ - V_T^-$	0.4	—	—	V	
Input high voltage	$\overline{RES}$ , $\overline{STBY}$ , NMI, MD <sub>2</sub> to MD <sub>0</sub>	$V_{IH}$	$V_{CC} - 0.7$	—	$V_{CC} + 0.3$	V	
	EXTAL		$V_{CC} \times 0.7$	—	$V_{CC} + 0.3$	V	
	Port 7		2.0	—	$AV_{CC} + 0.3$	V	
	Ports 1 to 6, P8 <sub>3</sub> , P8 <sub>4</sub> , P9 <sub>0</sub> to P9 <sub>5</sub> , port B		2.0	—	$V_{CC} + 0.3$	V	
Input low voltage	$\overline{RES}$ , $\overline{STBY}$ , MD <sub>2</sub> to MD <sub>0</sub>	$V_{IL}$	-0.3	—	0.5	V	
	NMI, EXTAL, ports 1 to 7, P8 <sub>3</sub> , P8 <sub>4</sub> , P9 <sub>0</sub> to P9 <sub>5</sub> , port B		-0.3	—	0.8	V	
Output high voltage	All output pins (except $\overline{RESO}$ )	$V_{OH}$	$V_{CC} - 0.5$	—	—	V	$I_{OH} = -200\ \mu\text{A}$
			3.5	—	—	V	$I_{OH} = -1\ \text{mA}$
Output low voltage	All output pins (except $\overline{RESO}$ )	$V_{OL}$	—	—	0.4	V	$I_{OL} = 1.6\ \text{mA}$
			—	—	1.0	V	$I_{OL} = 10\ \text{mA}$
			—	—	0.4	V	$I_{OL} = 2.6\ \text{mA}$

**Table 21.2 DC Characteristics (1) (cont)**

Conditions:  $V_{CC} = 5.0\text{ V} \pm 10\%$ ,  $AV_{CC} = 5.0\text{ V} \pm 10\%$ ,  $V_{REF} = 4.5\text{ V}$  to  $AV_{CC}^{*1}$ ,  
 $V_{SS} = AV_{SS} = 0\text{ V}^{*1}$ ,  $T_a = -20^\circ\text{C}$  to  $+75^\circ\text{C}$  (regular specifications),  
 $T_a = -40^\circ\text{C}$  to  $+85^\circ\text{C}$  (wide-range specifications)

Item	Symbol	Min	Typ	Max	Unit	Test Conditions	
Input leakage current	STBY, NMI, RES, MD <sub>2</sub> to MD <sub>0</sub>	$ I_{in} $	—	—	1.0	$\mu\text{A}$ $V_{in} = 0.5\text{ V}$ to $V_{CC} - 0.5\text{ V}$	
	Port 7	—	—	1.0	$\mu\text{A}$	$V_{in} = 0.5\text{ V}$ to $AV_{CC} - 0.5\text{ V}$	
Three-state leakage current	Ports 1 to 6 Ports 8 to B	$ I_{TSL} $	—	—	1.0	$\mu\text{A}$ $V_{in} = 0.5\text{ V}$ to $V_{CC} - 0.5\text{ V}$	
	$\overline{\text{RESO}}$	—	—	10.0	$\mu\text{A}$	$V_{in} = 0\text{ V}$	
Input pull-up MOS current	Ports 2, 4, and 5	$-I_p$	50	—	300	$\mu\text{A}$ $V_{in} = 0\text{ V}$	
Input capacitance	NMI	$C_{in}$	—	—	50	$\text{pF}$ $V_{in} = 0\text{ V}$	
	All input pins except NMI	—	—	—	15	$\text{pF}$ $f = 1\text{ MHz}$ $T_a = 25^\circ\text{C}$	
Current dissipation* <sup>2</sup>	Normal operation	$I_{CC}^{*3}$	—	55 (5.0 V)	100	$\text{mA}$ $f = 20\text{ MHz}$	
	Sleep mode	—	—	40 (5.0 V)	73	$\text{mA}$ $f = 20\text{ MHz}$	
	Module standby mode	—	—	24 (5.0 V)	51	$\text{mA}$ $f = 20\text{ MHz}$	
	Standby mode	—	—	0.01	5.0	$\mu\text{A}$	$T_a = 50^\circ\text{C}$
		—	—	—	—	20.0	$\mu\text{A}$ $50^\circ\text{C } T_a$

**Table 21.2 DC Characteristics (1) (cont)**

Conditions:  $V_{CC} = 5.0 \text{ V} \pm 10\%$ ,  $AV_{CC} = 5.0 \text{ V} \pm 10\%$ ,  $V_{REF} = 4.5 \text{ V}$  to  $AV_{CC}^{*1}$ ,  
 $V_{SS} = AV_{SS} = 0 \text{ V}^{*1}$ ,  $T_a = -20^\circ\text{C}$  to  $+75^\circ\text{C}$  (regular specifications),  
 $T_a = -40^\circ\text{C}$  to  $+85^\circ\text{C}$  (wide-range specifications)

Item		Symbol	Min	Typ	Max	Unit	Test Conditions
Analog power supply current	During A/D conversion	$AI_{CC}$	—	0.6	1.5	mA	
	During A/D and D/A conversion		—	0.6	1.5	mA	
	Idle		—	0.01	5.0	$\mu\text{A}$	DASTE = 0
Reference current	During A/D conversion	$AI_{CC}$	—	0.5	0.8	mA	
	During A/D and D/A conversion		—	2.0	3.0	mA	
	Idle		—	0.01	5.0	$\mu\text{A}$	DASTE = 0
RAM standby voltage		$V_{RAM}$	2.0	—	—	V	

Notes: 1. Do not open the pin connections of the  $AV_{CC}$ ,  $V_{REF}$  and  $AV_{SS}$  pins while the A/D converter is not in use.

Connect the  $AV_{CC}$  and  $V_{REF}$  pins to the  $V_{CC}$  and connect the  $AV_{SS}$  pin to the  $V_{SS}$ , respectively.

2. Given current consumption values are when all the output pins are made to unloaded state and, furthermore, when the on-chip pull-up MOS is turned off under conditions that  $V_{IH \text{ min}} = V_{CC} - 0.5 \text{ V}$  and  $V_{IL \text{ max}} = 0.5 \text{ V}$ .

Also, the aforesaid current consumption values are when  $V_{IH \text{ min}} = V_{CC} \times 0.9$  and  $V_{IL \text{ max}} = 0.3 \text{ V}$  under the condition of  $V_{RAM} V_{CC} < 4.5 \text{ V}$ .

3.  $I_{CC \text{ max}}$ . (under normal operations) =  $1.0 \text{ (mA)} + 0.90 \text{ (mA/(MHz} \times \text{V))} \times V_{CC} \times f$   
 $I_{CC \text{ max}}$ . (when using the sleeve) =  $1.0 \text{ (mA)} + 0.65 \text{ (mA/(MHz} \times \text{V))} \times V_{CC} \times f$   
 $I_{CC \text{ max}}$ . (when the sleeve + module are standing by)  
=  $1.0 \text{ (mA)} + 0.45 \text{ (mA/(MHz} \times \text{V))} \times V_{CC} \times f$

Also, the typ. values for current dissipation are reference values.



**Table 21.2 DC Characteristics (2)**

Conditions:  $V_{CC} = 2.7$  to  $5.5$  V,  $AV_{CC} = 2.7$  to  $5.5$  V,  $V_{REF} = 2.7$  V to  $AV_{CC}^{*1}$ ,  
 $V_{SS} = AV_{SS} = 0$  V<sup>\*1</sup>,  $T_a = -20^{\circ}\text{C}$  to  $+75^{\circ}\text{C}$  (regular specifications),  
 $T_a = -40^{\circ}\text{C}$  to  $+85^{\circ}\text{C}$  (wide-range specifications)

Item	Symbol	Min	Typ	Max	Unit	Test Conditions	
Schmitt trigger Port A, input voltages P8 <sub>0</sub> to P8 <sub>2</sub>	$V_T^-$	$V_{CC} \times 0.2$	—	—	V		
	$V_T^+$	—	—	$V_{CC} \times 0.7$	V		
	$V_T^+ - V_T^-$	$V_{CC} \times 0.07$	—	—	V		
Input high voltage	$\overline{RES}$ , $\overline{STBY}$ , NMI, MD <sub>2</sub> to MD <sub>0</sub>	$V_{IH}$	$V_{CC} \times 0.9$	—	$V_{CC} + 0.3$	V	
	EXTAL		$V_{CC} \times 0.7$	—	$V_{CC} + 0.3$	V	
	Port 7		$V_{CC} \times 0.7$	—	$AV_{CC} + 0.3$	V	
	Ports 1 to 6 P8 <sub>3</sub> , P8 <sub>4</sub> , P9 <sub>0</sub> to P9 <sub>5</sub> , port B		$V_{CC} \times 0.7$	—	$V_{CC} + 0.3$	V	
Input low voltage	$\overline{RES}$ , $\overline{STBY}$ , MD <sub>2</sub> to MD <sub>0</sub>	$V_{IL}$	-0.3	—	$V_{CC} \times 0.1$	V	
	NMI, EXTAL, ports 1 to 7 P8 <sub>3</sub> , P8 <sub>4</sub> , P9 <sub>0</sub> to P9 <sub>5</sub> , port B		-0.3	—	$V_{CC} \times 0.2$ 0.8	V V	$V_{CC} < 4.0$ V $V_{CC} = 4.0$ to 5.5 V
Output high voltage	All output pins (except $\overline{RES0}$ )	$V_{OH}$	$V_{CC} - 0.5$	—	—	V	$I_{OH} = -200$ $\mu$ A
			$V_{CC} - 1.0$	—	—	V	$I_{OH} = -1$ mA
Output low voltage	All output pins (except $\overline{RES0}$ )	$V_{OL}$	—	—	0.4	V	$I_{OL} = 1.6$ mA
	Ports 1, 2, and 5		—	—	1.0	V	$I_{OL} = 5$ mA ( $V_{CC} < 4.0$ V) $I_{OL} = 10$ mA ( $V_{CC} = 4.0$ to 5.5 V)
	$\overline{RES0}$		—	—	0.4	V	$I_{OL} = 1.6$ mA

**Table 21.2 DC Characteristics (2) (cont)**

Conditions:  $V_{CC} = 2.7$  to  $5.5$  V,  $AV_{CC} = 2.7$  to  $5.5$  V,  $V_{REF} = 2.7$  V to  $AV_{CC}^{*1}$ ,  
 $V_{SS} = AV_{SS} = 0$  V<sup>\*1</sup>,  $T_a = -20^{\circ}\text{C}$  to  $+75^{\circ}\text{C}$  (regular specifications),  
 $T_a = -40^{\circ}\text{C}$  to  $+85^{\circ}\text{C}$  (wide-range specifications)

Item	Symbol	Min	Typ	Max	Unit	Test Conditions	
Input leakage current	STBY, NMI, RES, MD <sub>2</sub> to MD <sub>0</sub>	$ I_{in} $	—	—	1.0	$\mu\text{A}$ $V_{in} = 0.5$ V to $V_{CC} - 0.5$ V	
	Port 7	—	—	1.0	$\mu\text{A}$	$V_{in} = 0.5$ V to $AV_{CC} - 0.5$ V	
Three-state leakage current	Ports 1 to 6 Ports 8 to B	$ I_{TSL} $	—	—	1.0	$\mu\text{A}$ $V_{in} = 0.5$ V to $V_{CC} - 0.5$ V	
	$\overline{\text{RESO}}$	—	—	10.0	$\mu\text{A}$	$V_{in} = 0$ V	
Input pull-up MOS current	Ports 2, 4, and 5	$-I_p$	10	—	300	$\mu\text{A}$ $V_{in} = 0$ V	
Input capacitance	NMI	$C_{in}$	—	—	50	$\text{pF}$ $V_{in} = 0$ V	
	All input pins except NMI	—	—	—	15	$\text{pF}$ $f = 1$ MHz $T_a = 25^{\circ}\text{C}$	
Current dissipation*2	Normal operation	$I_{CC}^{*3}$	—	18 (3.0 V)	51	$\text{mA}$ $f = 10$ MHz	
	Sleep mode	—	—	14 (3.0 V)	37	$\text{mA}$ $f = 10$ MHz	
	Module standby mode	—	—	8 (3.0 V)	26	$\text{mA}$ $f = 10$ MHz	
	Standby mode	—	—	0.01	5.0	$\mu\text{A}$	$T_a = 50^{\circ}\text{C}$
		—	—	—	20.0	$\mu\text{A}$	$50^{\circ}\text{C}$ $T_a$

**Table 21.2 DC Characteristics (2) (cont)**

Conditions:  $V_{CC} = 2.7$  to  $5.5$  V,  $AV_{CC} = 2.7$  to  $5.5$  V,  $V_{REF} = 2.7$  V to  $AV_{CC}^{*1}$ ,  
 $V_{SS} = AV_{SS} = 0$  V<sup>\*1</sup>,  $T_a = -20^{\circ}\text{C}$  to  $+75^{\circ}\text{C}$  (regular specifications),  
 $T_a = -40^{\circ}\text{C}$  to  $+85^{\circ}\text{C}$  (wide-range specifications)

Item		Symbol	Min	Typ	Max	Unit	Test Conditions
Analog power supply current	During A/D conversion	$AI_{CC}$	—	0.2	0.5	mA	$AV_{CC} = 3.0$ V
			—	0.6	—	mA	$AV_{CC} = 5.0$ V
	During A/D and D/A conversion		—	0.2	0.5	mA	$AV_{CC} = 3.0$ V
			—	0.6	—	mA	$AV_{CC} = 5.0$ V
Idle		—	0.01	5.0	$\mu\text{A}$	DASTE = 0	
Reference current	During A/D conversion	$AI_{CC}$	—	0.3	0.5	mA	$V_{REF} = 3.0$ V
			—	0.5	—	mA	$V_{REF} = 5.0$ V
	During A/D and D/A conversion		—	1.2	2.0	mA	$V_{REF} = 3.0$ V
			—	2.0	—	mA	$V_{REF} = 5.0$ V
Idle		—	0.01	5.0	$\mu\text{A}$	DASTE = 0	
RAM standby voltage		$V_{RAM}$	2.0	—	—	V	

Notes: 1. Do not open the pin connections of the  $AV_{CC}$ ,  $V_{REF}$  and  $AV_{SS}$  pins while the A/D converter is not in use.

Connect the  $AV_{CC}$  and  $V_{REF}$  pins to the  $V_{CC}$  and connect the  $AV_{SS}$  pin to the  $V_{SS}$ , respectively.

2. Given current consumption values are when all the output pins are made to unloaded state and, furthermore, when the on-chip pull-up MOS is turned off under conditions that  $V_{IH\ min} = V_{CC} - 0.5$  V and  $V_{IL\ max} = 0.5$  V.

Also, the aforesaid current consumption values are when  $V_{IH\ min} = V_{CC} \times 0.9$  and  $V_{IL\ max} = 0.3$  V under the condition of  $V_{RAM} = V_{CC} < 2.7$  V.

3.  $I_{CC\ max.}$  (under normal operations) =  $1.0$  (mA) +  $0.90$  (mA/(MHz  $\times$  V))  $\times V_{CC} \times f$   
 $I_{CC\ max.}$  (when using the sleeve) =  $1.0$  (mA) +  $0.65$  (mA/(MHz  $\times$  V))  $\times V_{CC} \times f$   
 $I_{CC\ max.}$  (when the sleeve + module are standing by) =  $1.0$  (mA) +  $0.45$  (mA/(MHz  $\times$  V))  $\times V_{CC} \times f$

Also, the typ. values for current dissipation are reference values.

**Table 21.2 DC Characteristics (3)**

Conditions:  $V_{CC} = 3.0$  to  $5.5$  V,  $AV_{CC} = 3.0$  to  $5.5$  V,  $V_{REF} = 3.0$  V to  $AV_{CC}^{*1}$ ,  
 $V_{SS} = AV_{SS} = 0$  V<sup>\*1</sup>,  $T_a = -20^{\circ}\text{C}$  to  $+75^{\circ}\text{C}$  (regular specifications),  
 $T_a = -40^{\circ}\text{C}$  to  $+85^{\circ}\text{C}$  (wide-range specifications)

Item	Symbol	Min	Typ	Max	Unit	Test Conditions	
Schmitt trigger input voltages	Port A, $P8_0$ to $P8_2$	$V_T^-$	$V_{CC} \times 0.2$	—	—	V	
		$V_T^+$	—	—	$V_{CC} \times 0.7$	V	
		$V_T^+ - V_T^-$	$V_{CC} \times 0.07$	—	—	V	
Input high voltage	$\overline{RES}$ , $\overline{STBY}$ , $\overline{NMI}$ , $MD_2$ to $MD_0$	$V_{IH}$	$V_{CC} \times 0.9$	—	$V_{CC} + 0.3$	V	
	EXTAL		$V_{CC} \times 0.7$	—	$V_{CC} + 0.3$	V	
	Port 7		$V_{CC} \times 0.7$	—	$AV_{CC} + 0.3$	V	
	Ports 1 to 6, $P8_3$ , $P8_4$ , $P9_0$ to $P9_5$ , port B		$V_{CC} \times 0.7$	—	$V_{CC} + 0.3$	V	
Input low voltage	$\overline{RES}$ , $\overline{STBY}$ , $MD_2$ to $MD_0$	$V_{IL}$	-0.3	—	$V_{CC} \times 0.1$	V	
	$\overline{NMI}$ , EXTAL, ports 1 to 7, $P8_3$ , $P8_4$ , $P9_0$ to $P9_5$ , port B		-0.3	—	$V_{CC} \times 0.2$ 0.8	V V	$V_{CC} < 4.0$ V $V_{CC} = 4.0$ to $5.5$ V
Output high voltage	All output pins (except $\overline{RESO}$ )	$V_{OH}$	$V_{CC} - 0.5$	—	—	V	$I_{OH} = -200$ $\mu\text{A}$
			$V_{CC} - 1.0$	—	—	V	$I_{OH} = -1$ mA
Output low voltage	All output pins (except $\overline{RESO}$ )	$V_{OL}$	—	—	0.4	V	$I_{OL} = 1.6$ mA
			—	—	1.0	V	$I_{OL} = 5$ mA ( $V_{CC} < 4.0$ V) $I_{OL} = 10$ mA ( $V_{CC} = 4.0$ to $5.5$ V)
	$\overline{RESO}$		—	—	0.4	V	$I_{OL} = 1.6$ mA

**Table 21.2 DC Characteristics (3) (cont)**

Conditions:  $V_{CC} = 3.0$  to  $5.5$  V,  $AV_{CC} = 3.0$  to  $5.5$  V,  $V_{REF} = 3.0$  V to  $AV_{CC}^{*1}$ ,  
 $V_{SS} = AV_{SS} = 0$  V<sup>\*1</sup>,  $T_a = -20^{\circ}\text{C}$  to  $+75^{\circ}\text{C}$  (regular specifications),  
 $T_a = -40^{\circ}\text{C}$  to  $+85^{\circ}\text{C}$  (wide-range specifications)

Item	Symbol	Min	Typ	Max	Unit	Test Conditions
Input leakage current	STBY, RES, NMI, MD <sub>2</sub> to MD <sub>0</sub>	$ I_{in} $	—	—	1.0	$\mu\text{A}$ $V_{in} = 0.5$ V to $V_{CC} - 0.5$ V
	Port 7	—	—	1.0	$\mu\text{A}$ $V_{in} = 0.5$ V to $AV_{CC} - 0.5$ V	
Three-state leakage current	Ports 1 to 6 Ports 8 to B	$ I_{TSL} $	—	—	1.0	$\mu\text{A}$ $V_{in} = 0.5$ V to $V_{CC} - 0.5$ V
	$\overline{\text{RESO}}$	—	—	10.0	$\mu\text{A}$ $V_{in} = 0$ V	
Input pull-up MOS current	Ports 2, 4, and 5	$-I_p$	10	—	300	$\mu\text{A}$ $V_{in} = 0$ V
Input capacitance	NMI	$C_{in}$	—	—	50	pF $V_{in} = 0$ V
	All input pins except NMI	—	—	—	15	pF $f = 1$ MHz $T_a = 25^{\circ}\text{C}$
Current dissipation <sup>*2</sup>	Normal operation	$I_{CC}^{*3}$	—	28 (3.5 V)	66	mA $f = 13$ MHz
	Sleep mode	—	—	20 (3.5 V)	48	mA $f = 13$ MHz
	Module standby mode	—	—	13 (3.5 V)	34	mA $f = 13$ MHz
	Standby mode	—	—	0.01	5.0	$\mu\text{A}$ $T_a = 50^{\circ}\text{C}$
	—	—	—	—	20.0	$\mu\text{A}$ $50^{\circ}\text{C}$ $T_a$

**Table 21.2 DC Characteristics (3) (cont)**

Conditions:  $V_{CC} = 3.0$  to  $5.5$  V,  $AV_{CC} = 3.0$  to  $5.5$  V,  $V_{REF} = 3.0$  V to  $AV_{CC}^{*1}$ ,  
 $V_{SS} = AV_{SS} = 0$  V<sup>\*1</sup>,  $T_a = -20^{\circ}\text{C}$  to  $+75^{\circ}\text{C}$  (regular specifications),  
 $T_a = -40^{\circ}\text{C}$  to  $+85^{\circ}\text{C}$  (wide-range specifications)

Item		Symbol	Min	Typ	Max	Unit	Test Conditions
Analog power supply current	During A/D conversion	$AI_{CC}$	—	0.2	0.5	mA	$AV_{CC} = 3.0$ V
			—	0.6	—	mA	$AV_{CC} = 5.0$ V
	During A/D and D/A conversion		—	0.2	0.5	mA	$AV_{CC} = 3.0$ V
			—	0.6	—	mA	$AV_{CC} = 5.0$ V
Idle		—	0.01	5.0	$\mu\text{A}$	DASTE = 0	
Reference current	During A/D conversion	$AI_{CC}$	—	0.3	0.5	mA	$V_{REF} = 3.0$ V
			—	0.5	—	mA	$V_{REF} = 5.0$ V
	During A/D and D/A conversion		—	1.2	2.0	mA	$V_{REF} = 3.0$ V
			—	2.0	—	mA	$V_{REF} = 5.0$ V
Idle		—	0.01	5.0	$\mu\text{A}$	DASTE = 0	
RAM standby voltage		$V_{RAM}$	2.0	—	—	V	

Notes: 1. Do not open the pin connections of the  $AV_{CC}$ ,  $V_{REF}$  and  $AV_{SS}$  pins while the A/D converter is not in use.

Connect the  $AV_{CC}$  and  $V_{REF}$  pins to the  $V_{CC}$  and connect the  $AV_{SS}$  pin to the  $V_{SS}$ , respectively.

2. Given current consumption values are when all the output pins are made to unloaded state and, furthermore, when the on-chip pull-up MOS is turned off under conditions that  $V_{IH\ min} = V_{CC} - 0.5$  V and  $V_{IL\ max} = 0.5$  V.

Also, the aforesaid current consumption values are when  $V_{IH\ min} = V_{CC} \times 0.9$  and  $V_{IL\ max} = 0.3$  V under the condition of  $V_{RAM} V_{CC} < 3.0$  V.

3.  $I_{CC\ max.}$  (under normal operations) =  $1.0$  (mA) +  $0.90$  (mA/(MHz  $\times$  V))  $\times V_{CC} \times f$   
 $I_{CC\ max.}$  (when using the sleeve) =  $1.0$  (mA) +  $0.65$  (mA/(MHz  $\times$  V))  $\times V_{CC} \times f$   
 $I_{CC\ max.}$  (when the sleeve + module are standing by)  
=  $1.0$  (mA) +  $0.45$  (mA/(MHz  $\times$  V))  $\times V_{CC} \times f$

Also, the typ. values for current dissipation are reference values.

### Table 21.3 Permissible Output Currents

Conditions:  $V_{CC} = 2.7\text{ V to }5.5\text{ V}$ ,  $AV_{CC} = 2.7\text{ V to }5.5\text{ V}$ ,  $V_{REF} = 2.7\text{ V to }AV_{CC}$ ,  
 $V_{SS} = AV_{SS} = 0\text{ V}$ ,  $T_a = -20^\circ\text{C to }+75^\circ\text{C}$  (regular specifications),  
 $T_a = -40^\circ\text{C to }+85^\circ\text{C}$  (wide-range specifications)

Item		Symbol	Min	Typ	Max	Unit
Permissible output low current (per pin)	Ports 1, 2, and 5	$I_{OL}$	—	—	10	mA
	Other output pins		—	—	2.0	mA
Permissible output low current (total)	Total of 20 pins in Ports 1, 2, and 5	$\Sigma I_{OL}$	—	—	80	mA
	Total of all output pins, including the above		—	—	120	mA
Permissible output high current (per pin)	All output pins	$ -I_{OH} $	—	—	2.0	mA
Permissible output high current (total)	Total of all output pins	$ \Sigma I_{OH} $	—	—	40	mA

- Notes: 1. To protect chip reliability, do not exceed the output current values in table 21.3.  
2. When driving a darlington pair, always insert a current-limiting resistor in the output line, as shown in figures 21.1 and 21.2.

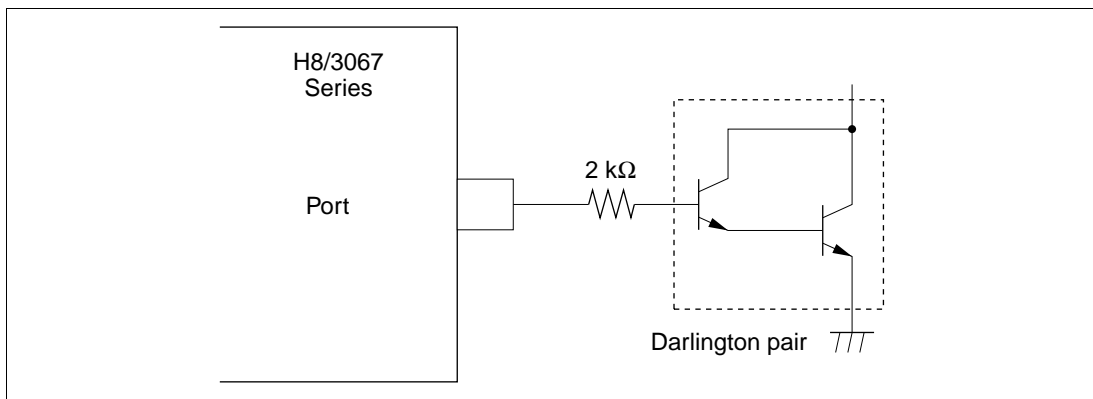
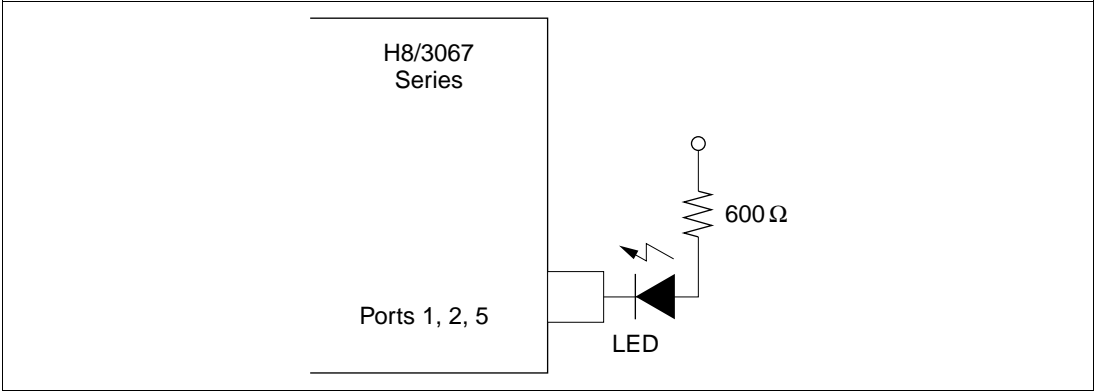


Figure 21.1 Darlington Pair Drive Circuit (Example)



**Figure 21.2 Sample LED Circuit**



### 21.1.3 AC Characteristics

Clock timing parameters are listed in table 21.4, control signal timing parameters in table 21.5, and bus timing parameters in table 21.6. Timing parameters of the on-chip supporting modules are listed in table 21.7.

**Table 21.4 Clock Timing**

Condition:  $T_a = -20^{\circ}\text{C}$  to  $+75^{\circ}\text{C}$  (regular specifications),  $T_a = -40^{\circ}\text{C}$  to  $+85^{\circ}\text{C}$  (wide-range specifications)

Condition A:  $V_{CC} = 2.7$  to  $5.5$  V,  $AV_{CC} = 2.7$  to  $5.5$  V,  $V_{REF} = 2.7$  to  $AV_{CC}$ ,  $V_{SS} = AV_{SS} = 0$  V

Condition B:  $V_{CC} = 3.0$  to  $5.5$  V,  $AV_{CC} = 3.0$  to  $5.5$  V,  $V_{REF} = 3.0$  to  $AV_{CC}$ ,  $V_{SS} = AV_{SS} = 0$  V

Condition C:  $V_{CC} = 5.0$  V  $\pm$  10%,  $AV_{CC} = 5.0$  V  $\pm$  10%,  $V_{REF} = 4.5$  to  $AV_{CC}$ ,  $V_{SS} = AV_{SS} = 0$  V

Item	Symbol	Condition						Unit	Test Conditions
		A		B		C			
		Min	Max	Min	Max	Min	Max		
Clock cycle time	$t_{cyc}$	100	1000	76.9	1000	50	1000	ns	Figure 21.11
Clock pulse low width	$t_{CL}$	30	—	18	—	15	—	ns	
Clock pulse high width	$t_{CH}$	30	—	18	—	15	—	ns	
Clock rise time	$t_{Cr}$	—	20	—	15	—	10	ns	
Clock fall time	$t_{Cf}$	—	20	—	15	—	10	ns	
Clock oscillator settling time at reset	$t_{OSC1}$	20	—	20	—	20	—	ms	Figure 21.7
Clock oscillator settling time in software standby	$t_{OSC2}$	7	—	7	—	7	—	ms	Figure 20.1

**Table 21.5 Control Signal Timing**

Condition:  $T_a = -20^{\circ}\text{C}$  to  $+75^{\circ}\text{C}$  (regular specifications),  $T_a = -40^{\circ}\text{C}$  to  $+85^{\circ}\text{C}$  (wide-range specifications)

Condition A:  $V_{CC} = 2.7$  to  $5.5$  V,  $AV_{CC} = 2.7$  to  $5.5$  V,  $V_{REF} = 2.7$  to  $AV_{CC}$ ,  $V_{SS} = AV_{SS} = 0$  V

Condition B:  $V_{CC} = 3.0$  to  $5.5$  V,  $AV_{CC} = 3.0$  to  $5.5$  V,  $V_{REF} = 3.0$  to  $AV_{CC}$ ,  $V_{SS} = AV_{SS} = 0$  V

Condition C:  $V_{CC} = 5.0$  V  $\pm$  10%,  $AV_{CC} = 5.0$  V  $\pm$  10%,  $V_{REF} = 4.5$  to  $AV_{CC}$ ,  $V_{SS} = AV_{SS} = 0$  V

Item	Symbol	Condition						Unit	Test Conditions
		A		B		C			
		Min	Max	Min	Max	Min	Max		
$\overline{\text{RES}}$ setup time	$t_{\text{RESS}}$	200	—	200	—	150	—	ns	Figure 21.8
$\overline{\text{RES}}$ pulse width	$t_{\text{RESW}}$	10	—	10	—	10	—	$t_{\text{cyc}}$	
Mode programming setup time	$t_{\text{MDS}}$	200	—	200	—	200	—	ns	
$\overline{\text{RESO}}$ output delay time	$t_{\text{RESD}}$	—	100	—	100	—	50	ns	Figure 21.9
$\overline{\text{RESO}}$ output pulse width	$t_{\text{RESOW}}$	132	—	132	—	132	—	$t_{\text{cyc}}$	
NMI, $\overline{\text{IRQ}}$ setup time	$t_{\text{NMIS}}$	200	—	200	—	150	—	ns	Figure 21.10
NMI, $\overline{\text{IRQ}}$ hold time	$t_{\text{NMIH}}$	10	—	10	—	10	—	ns	
NMI, $\overline{\text{IRQ}}$ pulse width	$t_{\text{NMIW}}$	200	—	200	—	200	—	ns	

**Table 21.6 Bus Timing**

Condition:  $T_a = -20^{\circ}\text{C}$  to  $+75^{\circ}\text{C}$  (regular specifications),  $T_a = -40^{\circ}\text{C}$  to  $+85^{\circ}\text{C}$  (wide-range specifications)

Condition A:  $V_{CC} = 2.7$  to  $5.5$  V,  $AV_{CC} = 2.7$  to  $5.5$  V,  $V_{REF} = 2.7$  to  $AV_{CC}$ ,  $V_{SS} = AV_{SS} = 0$  V

Condition B:  $V_{CC} = 3.0$  to  $5.5$  V,  $AV_{CC} = 3.0$  to  $5.5$  V,  $V_{REF} = 3.0$  to  $AV_{CC}$ ,  $V_{SS} = AV_{SS} = 0$  V

Condition C:  $V_{CC} = 5.0$  V  $\pm$  10%,  $AV_{CC} = 5.0$  V  $\pm$  10%,  $V_{REF} = 4.5$  to  $AV_{CC}$ ,  $V_{SS} = AV_{SS} = 0$  V

Item	Symbol	Condition						Unit	Test Conditions
		A		B		C			
		Min	Max	Min	Max	Min	Max		
Address delay time	$t_{AD}$	—	50	—	40	—	25	ns	Figure 21.11, figure 21.12, figure 21.14, figure 21.15, figure 21.17
Address hold time	$t_{AH}$	$0.5 t_{cyc}$ – 45	—	$0.5 t_{cyc}$ – 35	—	$0.5 t_{cyc}$ – 20	—	ns	
Read strobe delay time	$t_{RSD}$	—	60	—	50	—	25	ns	
Address strobe delay time	$t_{ASD}$	—	60	—	50	—	25	ns	
Write strobe delay time	$t_{WSD}$	—	60	—	50	—	25	ns	
Strobe delay time	$t_{SD}$	—	60	—	50	—	25	ns	
Write strobe pulse width 1	$t_{WSW1}$	$1.0 t_{cyc}$ – 50	—	$1.0 t_{cyc}$ – 40	—	$1.0 t_{cyc}$ – 25	—	ns	
Write strobe pulse width 2	$t_{WSW2}$	$1.5 t_{cyc}$ – 50	—	$1.5 t_{cyc}$ – 40	—	$1.5 t_{cyc}$ – 25	—	ns	
Address setup time 1	$t_{AS1}$	$0.5 t_{cyc}$ – 45	—	$0.5 t_{cyc}$ – 29	—	$0.5 t_{cyc}$ – 20	—	ns	
Address setup time 2	$t_{AS2}$	$1.0 t_{cyc}$ – 45	—	$1.0 t_{cyc}$ – 35	—	$1.0 t_{cyc}$ – 20	—	ns	
Read data setup time	$t_{RDS}$	50	—	40	—	25	—	ns	
Read data hold time	$t_{RDH}$	0	—	0	—	0	—	ns	

**Table 21.6 Bus Timing (cont)**

Condition:  $T_a = -20^{\circ}\text{C}$  to  $+75^{\circ}\text{C}$  (regular specifications),  $T_a = -40^{\circ}\text{C}$  to  $+85^{\circ}\text{C}$  (wide-range specifications)

Condition A:  $V_{CC} = 2.7$  to  $5.5$  V,  $AV_{CC} = 2.7$  to  $5.5$  V,  $V_{REF} = 2.7$  to  $AV_{CC}$ ,  $V_{SS} = AV_{SS} = 0$  V

Condition B:  $V_{CC} = 3.0$  to  $5.5$  V,  $AV_{CC} = 3.0$  to  $5.5$  V,  $V_{REF} = 3.0$  to  $AV_{CC}$ ,  $V_{SS} = AV_{SS} = 0$  V

Condition C:  $V_{CC} = 5.0$  V  $\pm$  10%,  $AV_{CC} = 5.0$  V  $\pm$  10%,  $V_{REF} = 4.5$  to  $AV_{CC}$ ,  $V_{SS} = AV_{SS} = 0$  V

Item	Symbol	Condition						Unit	Test Conditions
		A		B		C			
		Min	Max	Min	Max	Min	Max		
Write data delay time	$t_{WDD}$	—	60	—	50	—	35	ns	Figure 21.11, figure 21.12, figure 21.14, figure 21.15, figure 21.17
Write data setup time 1	$t_{WDS1}$	$1.0 t_{cyc}$ – 50	—	$1.0 t_{cyc}$ – 40	—	$1.0 t_{cyc}$ – 30	—	ns	
Write data setup time 2	$t_{WDS2}$	$2.0 t_{cyc}$ – 50	—	$2.0 t_{cyc}$ – 40	—	$2.0 t_{cyc}$ – 30	—	ns	
Write data hold time	$t_{WDH}$	$0.5 t_{cyc}$ – 30	—	$0.5 t_{cyc}$ – 25	—	$0.5 t_{cyc}$ – 15	—	ns	
Read data access time 1	$t_{ACC1}$	—	$2.0 t_{cyc}$ – 100	—	$2.0 t_{cyc}$ – 80	—	$2.0 t_{cyc}$ – 45	ns	
Read data access time 2	$t_{ACC2}$	—	$3.0 t_{cyc}$ – 100	—	$3.0 t_{cyc}$ – 80	—	$3.0 t_{cyc}$ – 45	ns	
Read data access time 3	$t_{ACC3}$	—	$1.5 t_{cyc}$ – 100	—	$1.5 t_{cyc}$ – 80	—	$1.5 t_{cyc}$ – 45	ns	
Read data access time 4	$t_{ACC4}$	—	$2.5 t_{cyc}$ – 100	—	$2.5 t_{cyc}$ – 80	—	$2.5 t_{cyc}$ – 45	ns	
Precharge time 1	$t_{PCH1}$	$1.0 t_{cyc}$ – 40	—	$1.0 t_{cyc}$ – 30	—	$1.0 t_{cyc}$ – 20	—	ns	
Precharge time 2	$t_{PCH2}$	$0.5 t_{cyc}$ – 40	—	$0.5 t_{cyc}$ – 30	—	$0.5 t_{cyc}$ – 20	—	ns	
Wait setup time	$t_{WTS}$	40	—	40	—	25	—	ns	Figure 21.13
Wait hold time	$t_{WTH}$	5	—	5	—	5	—	ns	
Bus request setup time	$t_{BRQS}$	40	—	40	—	25	—	ns	Figure 21.16
Bus acknowledge delay time 1	$t_{BACD1}$	—	60	—	50	—	30	ns	
Bus acknowledge delay time 2	$t_{BACD2}$	—	60	—	50	—	30	ns	

**Table 21.6 Bus Timing (cont)**

Condition:  $T_a = -20^{\circ}\text{C}$  to  $+75^{\circ}\text{C}$  (regular specifications),  $T_a = -40^{\circ}\text{C}$  to  $+85^{\circ}\text{C}$  (wide-range specifications)

Condition A:  $V_{CC} = 2.7$  to  $5.5$  V,  $AV_{CC} = 2.7$  to  $5.5$  V,  $V_{REF} = 2.7$  to  $AV_{CC}$ ,  $V_{SS} = AV_{SS} = 0$  V

Condition B:  $V_{CC} = 3.0$  to  $5.5$  V,  $AV_{CC} = 3.0$  to  $5.5$  V,  $V_{REF} = 3.0$  to  $AV_{CC}$ ,  $V_{SS} = AV_{SS} = 0$  V

Condition C:  $V_{CC} = 5.0$  V  $\pm$  10%,  $AV_{CC} = 5.0$  V  $\pm$  10%,  $V_{REF} = 4.5$  to  $AV_{CC}$ ,  $V_{SS} = AV_{SS} = 0$  V

Item	Symbol	Condition						Unit	Test Conditions
		A		B		C			
		Min	Max	Min	Max	Min	Max		
Bus-floating time	$t_{BZD}$	—	60	—	50	—	30	ns	Figure 21.16
$\overline{\text{RAS}}$ precharge time	$t_{RP}$	$1.5 t_{cyc}$ – 50	—	$1.5 t_{cyc}$ – 40	—	$1.5 t_{cyc}$ – 25	—	ns	Figure 21.17 to figure 21.19
$\overline{\text{CAS}}$ precharge time	$t_{CP}$	$0.5 t_{cyc}$ – 30	—	$0.5 t_{cyc}$ – 25	—	$0.5 t_{cyc}$ – 15	—	ns	
Low address hold time	$t_{RAH}$	$0.5 t_{cyc}$ – 30	—	$0.5 t_{cyc}$ – 25	—	$0.5 t_{cyc}$ – 15	—	ns	
$\overline{\text{RAS}}$ delay time 1	$t_{RAD1}$	—	60	—	50	—	25	ns	
$\overline{\text{RAS}}$ delay time 2	$t_{RAD2}$	—	60	—	50	—	30	ns	
$\overline{\text{CAS}}$ delay time 1	$t_{CASD1}$	—	60	—	50	—	25	ns	
$\overline{\text{CAS}}$ delay time 2	$t_{CASD2}$	—	60	—	50	—	25	ns	
$\overline{\text{WE}}$ delay time	$t_{WCD}$	—	60	—	50	—	25	ns	
$\overline{\text{CAS}}$ pulse width 1	$t_{CAS1}$	$1.5 t_{cyc}$ – 50	—	$1.5 t_{cyc}$ – 40	—	$1.5 t_{cyc}$ – 20	—	ns	
$\overline{\text{CAS}}$ pulse width 2	$t_{CAS2}$	$1.0 t_{cyc}$ – 50	—	$1.0 t_{cyc}$ – 40	—	$1.0 t_{cyc}$ – 20	—	ns	
$\overline{\text{CAS}}$ pulse width 3	$t_{CAS3}$	$1.0 t_{cyc}$ – 50	—	$1.0 t_{cyc}$ – 40	—	$1.0 t_{cyc}$ – 20	—	ns	
$\overline{\text{RAS}}$ access time	$t_{RAC}$	—	$2.5 t_{cyc}$ – 80	—	$2.5 t_{cyc}$ – 70	—	$2.5 t_{cyc}$ – 40	ns	
Address access time	$t_{AA}$	—	$2.0 t_{cyc}$ – 100	—	$2.0 t_{cyc}$ – 80	—	$2.0 t_{cyc}$ – 50	ns	
$\overline{\text{CAS}}$ access time	$t_{CAC}$	—	$1.5 t_{cyc}$ – 100	—	$1.5 t_{cyc}$ – 80	—	$1.5 t_{cyc}$ – 50	ns	
$\overline{\text{WE}}$ setup time	$t_{WCS}$	$0.5 t_{cyc}$ – 45	—	$0.5 t_{cyc}$ – 35	—	$0.5 t_{cyc}$ – 20	—	ns	

**Table 21.6 Bus Timing (cont)**

Condition:  $T_a = -20^{\circ}\text{C}$  to  $+75^{\circ}\text{C}$  (regular specifications),  $T_a = -40^{\circ}\text{C}$  to  $+85^{\circ}\text{C}$  (wide-range specifications)

Condition A:  $V_{CC} = 2.7$  to  $5.5$  V,  $AV_{CC} = 2.7$  to  $5.5$  V,  $V_{REF} = 2.7$  to  $AV_{CC}$ ,  $V_{SS} = AV_{SS} = 0$  V

Condition B:  $V_{CC} = 3.0$  to  $5.5$  V,  $AV_{CC} = 3.0$  to  $5.5$  V,  $V_{REF} = 3.0$  to  $AV_{CC}$ ,  $V_{SS} = AV_{SS} = 0$  V

Condition C:  $V_{CC} = 5.0$  V  $\pm$  10%,  $AV_{CC} = 5.0$  V  $\pm$  10%,  $V_{REF} = 4.5$  to  $AV_{CC}$ ,  $V_{SS} = AV_{SS} = 0$  V

Item	Symbol	Condition						Unit	Test Conditions
		A		B		C			
		Min	Max	Min	Max	Min	Max		
$\overline{\text{WE}}$ hold time	$t_{\text{WCH}}$	$0.5 t_{\text{cyc}}$ - 40	—	$0.5 t_{\text{cyc}}$ - 28	—	$0.5 t_{\text{cyc}}$ - 15	—	ns	Figure 21.17 to
Write data setup time	$t_{\text{WDS}}$	$0.5 t_{\text{cyc}}$ - 45	—	$0.5 t_{\text{cyc}}$ - 35	—	$0.5 t_{\text{cyc}}$ - 20	—	ns	figure 21.19
$\overline{\text{WE}}$ write data hold time	$t_{\text{WDH}}$	$0.5 t_{\text{cyc}}$ - 30	—	$0.5 t_{\text{cyc}}$ - 25	—	$0.5 t_{\text{cyc}}$ - 15	—	ns	
$\overline{\text{CAS}}$ setup time 1	$t_{\text{CSR1}}$	$0.5 t_{\text{cyc}}$ - 30	—	$0.5 t_{\text{cyc}}$ - 25	—	$0.5 t_{\text{cyc}}$ - 20	—	ns	
$\overline{\text{CAS}}$ setup time 2	$t_{\text{CSR2}}$	$0.5 t_{\text{cyc}}$ - 30	—	$0.5 t_{\text{cyc}}$ - 25	—	$0.5 t_{\text{cyc}}$ - 15	—	ns	
$\overline{\text{CAS}}$ hold time	$t_{\text{CHR}}$	$0.5 t_{\text{cyc}}$ - 30	—	$0.5 t_{\text{cyc}}$ - 25	—	$0.5 t_{\text{cyc}}$ - 15	—	ns	
$\overline{\text{RAS}}$ pulse width	$t_{\text{RAS}}$	$1.5 t_{\text{cyc}}$ - 30	—	$1.5 t_{\text{cyc}}$ - 25	—	$1.5 t_{\text{cyc}}$ - 15	—	ns	

**Table 21.7 Timing of On-Chip Supporting Modules**

Condition:  $T_a = -20^{\circ}\text{C}$  to  $+75^{\circ}\text{C}$  (regular specifications),  $T_a = -40^{\circ}\text{C}$  to  $+85^{\circ}\text{C}$  (wide-range specifications)

Condition A:  $V_{CC} = 2.7$  to  $5.5$  V,  $AV_{CC} = 2.7$  to  $5.5$  V,  $V_{REF} = 2.7$  to  $AV_{CC}$ ,  $V_{SS} = AV_{SS} = 0$  V

Condition B:  $V_{CC} = 3.0$  to  $5.5$  V,  $AV_{CC} = 3.0$  to  $5.5$  V,  $V_{REF} = 3.0$  to  $AV_{CC}$ ,  $V_{SS} = AV_{SS} = 0$  V

Condition C:  $V_{CC} = 5.0$  V  $\pm$  10%,  $AV_{CC} = 5.0$  V  $\pm$  10%,  $V_{REF} = 4.5$  to  $AV_{CC}$ ,  $V_{SS} = AV_{SS} = 0$  V

Item	Symbol	Condition						Unit	Test Conditions	
		A		B		C				
		Min	Max	Min	Max	Min	Max			
Ports and TPC	Output data delay time	$t_{PWD}$	—	100	—	100	—	50	ns	Figure 21.20
	Input data setup time	$t_{PRS}$	50	—	50	—	50	—	ns	
	Input data hold time	$t_{PRH}$	50	—	50	—	50	—	ns	
16-bit timer	Timer output delay time	$t_{TOCD}$	—	100	—	100	—	50	ns	Figure 21.21
	Timer input setup time	$t_{TICS}$	50	—	50	—	50	—	ns	
	Timer clock input setup time	$t_{TCKS}$	50	—	50	—	50	—	ns	Figure 21.22
	Timer clock pulse width	Single edge	$t_{TCKWH}$	1.5	—	1.5	—	1.5	—	$t_{cyc}$
Both edges		$t_{TCKWL}$	2.5	—	2.5	—	2.5	—	$t_{cyc}$	
8-bit timer	Timer output delay time	$t_{TOCD}$	—	100	—	100	—	50	ns	Figure 21.21
	Timer input setup time	$t_{TICS}$	50	—	50	—	50	—	ns	
	Timer clock input setup time	$t_{TCKS}$	50	—	50	—	50	—	ns	Figure 21.22
	Timer clock pulse width	Single edge	$t_{TCKWH}$	1.5	—	1.5	—	1.5	—	$t_{cyc}$
Both edges		$t_{TCKWL}$	2.5	—	2.5	—	2.5	—	$t_{cyc}$	

**Table 21.7 Timing of On-Chip Supporting Modules (cont)**

Condition:  $T_a = -20^{\circ}\text{C}$  to  $+75^{\circ}\text{C}$  (regular specifications),  $T_a = -40^{\circ}\text{C}$  to  $+85^{\circ}\text{C}$  (wide-range specifications)

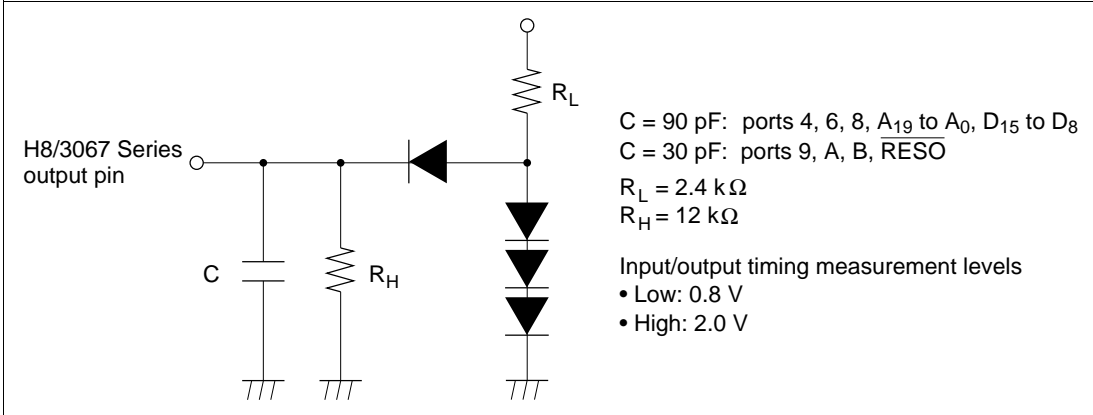
Condition A:  $V_{CC} = 2.7$  to  $5.5$  V,  $AV_{CC} = 2.7$  to  $5.5$  V,  $V_{REF} = 2.7$  to  $AV_{CC}$ ,  $V_{SS} = AV_{SS} = 0$  V

Condition B:  $V_{CC} = 3.0$  to  $5.5$  V,  $AV_{CC} = 3.0$  to  $5.5$  V,  $V_{REF} = 3.0$  to  $AV_{CC}$ ,  $V_{SS} = AV_{SS} = 0$  V

Condition C:  $V_{CC} = 5.0$  V  $\pm$  10%,  $AV_{CC} = 5.0$  V  $\pm$  10%,  $V_{REF} = 4.5$  to  $AV_{CC}$ ,  $V_{SS} = AV_{SS} = 0$  V

Item	Symbol	Condition						Unit	Test Conditions		
		A		B		C					
		Min	Max	Min	Max	Min	Max				
SCI	Input clock cycle	Asynchronous	$t_{S_{cyc}}$	4	—	4	—	4	—	$t_{cyc}$	Figure 21.23
		Synchronous		6	—	6	—	6	—	$t_{cyc}$	
	Input clock rise time	$t_{S_{CKr}}$	1.5	—	1.5	—	1.5	—	$t_{cyc}$		
	Input clock fall time	$t_{S_{CKf}}$	1.5	—	1.5	—	1.5	—	$t_{cyc}$		
	Input clock pulse width	$t_{S_{CKW}}$	0.4	0.6	0.4	0.6	0.4	0.6	$t_{S_{cyc}}$		
	Transmit data delay time	$t_{TXD}$	—	100	—	100	—	100	ns	Figure 21.24	
	Receive data setup time (synchronous)	$t_{RXS}$	100	—	100	—	100	—	ns		
	Receive data hold time (synchronous)	Clock input	$t_{RXH}$	100	—	100	—	100	—	ns	
			Clock output		0	—	0	—	0	—	ns
DMAC	$\overline{TEND}$ delay time 1	$t_{TED1}$	—	100	—	100	—	50	ns	Figure 21.25, figure 21.26	
	$\overline{TEND}$ delay time 2	$t_{TED2}$	—	100	—	100	—	50	ns		
	$\overline{DREQ}$ setup time	$t_{DRQS}$	40	—	40	—	25	—	ns	Figure 21.27	
	$\overline{DREQ}$ hold time	$t_{DRQH}$	10	—	10	—	10	—	ns		





**Figure 21.3 Output Load Circuit**

## 21.1.4 A/D Conversion Characteristics

Table 21.8 lists the A/D conversion characteristics.

**Table 21.8 A/D Conversion Characteristics**

Condition:  $T_a = -20^\circ\text{C}$  to  $+75^\circ\text{C}$  (regular specifications),  $T_a = -40^\circ\text{C}$  to  $+85^\circ\text{C}$  (wide-range specifications)

Condition A:  $V_{CC} = 2.7$  to  $5.5$  V,  $AV_{CC} = 2.7$  to  $5.5$  V,  $V_{REF} = 2.7$  to  $AV_{CC}$ ,  $V_{SS} = AV_{SS} = 0$  V,  $f_{max} = 10$  MHz

Condition B:  $V_{CC} = 3.0$  to  $5.5$  V,  $AV_{CC} = 3.0$  to  $5.5$  V,  $V_{REF} = 3.0$  to  $AV_{CC}$ ,  $V_{SS} = AV_{SS} = 0$  V,  $f_{max} = 13$  MHz

Condition C:  $V_{CC} = 5.0$  V  $\pm$  10%,  $AV_{CC} = 5.0$  V  $\pm$  10%,  $V_{REF} = 4.5$  to  $AV_{CC}$ ,  $V_{SS} = AV_{SS} = 0$  V,  $f_{max} = 20$  MHz

Item		Condition									Unit	
		A			B			C				
		Min	Typ	Max	Min	Typ	Max	Min	Typ	Max		
Conversion time: 134 states	Resolution	10	10	10	10	10	10	10	10	10	bits	
	Conversion time (single mode)	—	—	134	—	—	134	—	—	134	$t_{cyc}$	
	Analog input capacitance	—	—	20	—	—	20	—	—	20	pF	
	Permissible signal-source impedance	$\phi$ 13 MHz	—	—	—	—	—	—	—	—	10	k
		$\phi > 13$ MHz	—	—	—	—	—	—	—	—	5	k
		4.0 V $AV_{CC}$ 5.5 V	—	—	10	—	—	10	—	—	—	k
		2.7 V $AV_{CC}$ < 4.0 V	—	—	5	—	—	5	—	—	—	k
	Nonlinearity error	—	—	$\pm 7.5$	—	—	$\pm 7.5$	—	—	$\pm 3.5$	LSB	
	Offset error	—	—	$\pm 7.5$	—	—	$\pm 7.5$	—	—	$\pm 3.5$	LSB	
	Full-scale error	—	—	$\pm 7.5$	—	—	$\pm 7.5$	—	—	$\pm 3.5$	LSB	
Quantization error	—	—	$\pm 0.5$	—	—	$\pm 0.5$	—	—	$\pm 0.5$	LSB		
Absolute accuracy	—	—	$\pm 8.0$	—	—	$\pm 8.0$	—	—	$\pm 4.0$	LSB		

**Table 21.8 A/D Conversion Characteristics (cont)**

Condition:  $T_a = -20^{\circ}\text{C}$  to  $+75^{\circ}\text{C}$  (regular specifications),  $T_a = -40^{\circ}\text{C}$  to  $+85^{\circ}\text{C}$  (wide-range specifications)

Condition A:  $V_{CC} = 2.7$  to  $5.5$  V,  $AV_{CC} = 2.7$  to  $5.5$  V,  $V_{REF} = 2.7$  to  $AV_{CC}$ ,  $V_{SS} = AV_{SS} = 0$  V,  $f_{max} = 10$  MHz

Condition B:  $V_{CC} = 3.0$  to  $5.5$  V,  $AV_{CC} = 3.0$  to  $5.5$  V,  $V_{REF} = 3.0$  to  $AV_{CC}$ ,  $V_{SS} = AV_{SS} = 0$  V,  $f_{max} = 13$  MHz

Condition C:  $V_{CC} = 5.0$  V  $\pm 10\%$ ,  $AV_{CC} = 5.0$  V  $\pm 10\%$ ,  $V_{REF} = 4.5$  to  $AV_{CC}$ ,  $V_{SS} = AV_{SS} = 0$  V,  $f_{max} = 20$  MHz

Item		Condition									Unit	
		A			B			C				
		Min	Typ	Max	Min	Typ	Max	Min	Typ	Max		
Conversion time: 70 states	Resolution	10	10	10	10	10	10	10	10	10	bits	
	Conversion time (single mode)	—	—	70	—	—	70	—	—	70	$t_{cyc}$	
	Analog input capacitance	—	—	20	—	—	20	—	—	20	pF	
	Permissible signal-source impedance	$\phi$ 13 MHz	—	—	—	—	—	—	—	—	5	k
		$\phi > 13$ MHz	—	—	—	—	—	—	—	—	3	k
		4.0 V $AV_{CC}$ 5.5 V	—	—	5	—	—	5	—	—	—	k
		2.7 V $AV_{CC}$ < 4.0 V	—	—	3	—	—	3	—	—	—	k
	Nonlinearity error	—	—	$\pm 15.5$	—	—	$\pm 15.5$	—	—	$\pm 7.5$	LSB	
	Offset error	—	—	$\pm 15.5$	—	—	$\pm 15.5$	—	—	$\pm 7.5$	LSB	
	Full-scale error	—	—	$\pm 15.5$	—	—	$\pm 15.5$	—	—	$\pm 7.5$	LSB	
Quantization error	—	—	$\pm 0.5$	—	—	$\pm 0.5$	—	—	$\pm 0.5$	LSB		
Absolute accuracy	—	—	$\pm 16$	—	—	$\pm 16$	—	—	$\pm 8.0$	LSB		

## 21.1.5 D/A Conversion Characteristics

Table 21.9 lists the D/A conversion characteristics.

**Table 21.9 D/A Conversion Characteristics**

Condition:  $T_a = -20^\circ\text{C}$  to  $+75^\circ\text{C}$  (regular specifications),  $T_a = -40^\circ\text{C}$  to  $+85^\circ\text{C}$  (wide-range specifications)

Condition A:  $V_{CC} = 2.7$  to  $5.5$  V,  $AV_{CC} = 2.7$  to  $5.5$  V,  $V_{REF} = 2.7$  to  $AV_{CC}$ ,  $V_{SS} = AV_{SS} = 0$  V,  $f_{max} = 10$  MHz

Condition B:  $V_{CC} = 3.0$  to  $5.5$  V,  $AV_{CC} = 3.0$  to  $5.5$  V,  $V_{REF} = 3.0$  to  $AV_{CC}$ ,  $V_{SS} = AV_{SS} = 0$  V,  $f_{max} = 13$  MHz

Condition C:  $V_{CC} = 5.0$  V  $\pm$  10%,  $AV_{CC} = 5.0$  V  $\pm$  10%,  $V_{REF} = 4.5$  to  $AV_{CC}$ ,  $V_{SS} = AV_{SS} = 0$  V,  $f_{max} = 20$  MHz

Item	Condition									Unit	Test Conditions
	A			B			C				
	Min	Typ	Max	Min	Typ	Max	Min	Typ	Max		
Resolution	8	8	8	8	8	8	8	8	8	bits	
Conversion time (centering time)	—	—	10	—	—	10	—	—	10	$\mu\text{s}$	20 pF capacitive load
Absolute accuracy	—	$\pm 2.0$	$\pm 3.0$	—	$\pm 2.0$	$\pm 3.0$	—	$\pm 1.5$	$\pm 2.0$	LSB	2 M resistive load
	—	—	$\pm 2.0$	—	—	$\pm 2.0$	—	—	$\pm 1.5$	LSB	4 M resistive load

## 21.2 Electrical Characteristics of Flash Memory and Flash Memory R Versions

### 21.2.1 Absolute Maximum Ratings

Table 21.10 lists the absolute maximum ratings.

**Table 21.10 Absolute Maximum Ratings**

Item	Symbol	Value	Unit
Power supply voltage	$V_{CC}$	-0.3 to +7.0	V
Programming voltage (FWE)* <sup>1</sup>	$V_{in}$	-0.3 to $V_{CC} + 0.3$	V
Input voltage (except for port 7)* <sup>1</sup>	$V_{in}$	-0.3 to $V_{CC} + 0.3$	V
Input voltage (port 7)	$V_{in}$	-0.3 to $AV_{CC} + 0.3$	V
Reference voltage	$V_{REF}$	-0.3 to $AV_{CC} + 0.3$	V
Analog power supply voltage	$AV_{CC}$	-0.3 to +7.0	V
Analog input voltage	$V_{AN}$	-0.3 to $AV_{CC} + 0.3$	V
Operating temperature	$T_{opr}$	Regular specifications: -20 to +75* <sup>2</sup>	°C
		Wide-range specifications: -40 to +85* <sup>2</sup>	°C
Storage temperature	$T_{stg}$	-55 to +125	°C

Caution: Permanent damage to the chip may result if absolute maximum ratings are exceeded.

- Notes: 1. 12 V must not be applied to any pin, as this may cause permanent damage to the device.
2. The operating temperature range when programming and erasing the flash memory is:  $T_a = 0$  to +75°C (regular specifications),  $T_a = 0$  to +85°C (wide-range specifications).

## 21.2.2 DC Characteristics

Tables 21.11 lists the DC characteristics. Table 21.12 lists the permissible output currents.

**Table 21.11 DC Characteristics (1)**

Conditions:  $V_{CC} = 5.0\text{ V} \pm 10\%$ ,  $AV_{CC} = 5.0\text{ V} \pm 10\%$ ,  $V_{REF} = 4.5\text{ V}$  to  $AV_{CC}^{*1}$ ,  
 $V_{SS} = AV_{SS} = 0\text{ V}^{*1}$ ,  $T_a = -20^\circ\text{C}$  to  $+75^\circ\text{C}$  (regular specifications),  
 $T_a = -40^\circ\text{C}$  to  $+85^\circ\text{C}$  (wide-range specifications)  
 [Programming/erasing conditions:  $T_a = 0^\circ\text{C}$  to  $+75^\circ\text{C}$  (regular specifications),  
 $T_a = 0^\circ\text{C}$  to  $+85^\circ\text{C}$  (wide-range specifications)]

Item		Symbol	Min	Typ	Max	Unit	Test Conditions
Schmitt trigger input voltages	Port A, P8 <sub>0</sub> to P8 <sub>2</sub>	$V_T^-$	1.0	—	—	V	
		$V_T^+$	—	—	$V_{CC} \times 0.7$	V	
		$V_T^+ - V_T^-$	0.4	—	—	V	
Input high voltage	$\overline{RES}$ , $\overline{STBY}$ , NMI, MD <sub>2</sub> to MD <sub>0</sub> , FWE	$V_{IH}$	$V_{CC} - 0.7$	—	$V_{CC} + 0.3$	V	
	EXTAL		$V_{CC} \times 0.7$	—	$V_{CC} + 0.3$	V	
	Port 7		2.0	—	$AV_{CC} + 0.3$	V	
	Ports 1 to 6, P8 <sub>3</sub> , P8 <sub>4</sub> , P9 <sub>0</sub> to P9 <sub>5</sub> , port B		2.0	—	$V_{CC} + 0.3$	V	
Input low voltage	$\overline{RES}$ , $\overline{STBY}$ , FWE, MD <sub>2</sub> to MD <sub>0</sub>	$V_{IL}$	-0.3	—	0.5	V	
	NMI, EXTAL, ports 1 to 7, P8 <sub>3</sub> , P8 <sub>4</sub> , P9 <sub>0</sub> to P9 <sub>5</sub> , port B		-0.3	—	0.8	V	
Output high voltage	All output pins	$V_{OH}$	$V_{CC} - 0.5$	—	—	V	$I_{OH} = -200\ \mu\text{A}$
			3.5	—	—	V	$I_{OH} = -1\ \text{mA}$
Output low voltage	All output pins	$V_{OL}$	—	—	0.4	V	$I_{OL} = 1.6\ \text{mA}$
			Ports 1, 2, and 5	—	—	1.0	V

**Table 21.11 DC Characteristics (1) (cont)**

Conditions:  $V_{CC} = 5.0 \text{ V} \pm 10\%$ ,  $AV_{CC} = 5.0 \text{ V} \pm 10\%$ ,  $V_{REF} = 4.5 \text{ V}$  to  $AV_{CC}^{*1}$ ,  
 $V_{SS} = AV_{SS} = 0 \text{ V}^{*1}$ ,  $T_a = -20^\circ\text{C}$  to  $+75^\circ\text{C}$  (regular specifications),  
 $T_a = -40^\circ\text{C}$  to  $+85^\circ\text{C}$  (wide-range specifications)  
 [Programming/erasing conditions:  $T_a = 0^\circ\text{C}$  to  $+75^\circ\text{C}$  (regular specifications),  
 $T_a = 0^\circ\text{C}$  to  $+85^\circ\text{C}$  (wide-range specifications)]

Item	Symbol	Min	Typ	Max	Unit	Test Conditions	
Input leakage current	$\overline{\text{STBY}}$ , $\overline{\text{RES}}$ , NMI, FWE MD <sub>2</sub> to MD <sub>0</sub>	$ I_{in} $	—	—	1.0	$\mu\text{A}$ $V_{in} = 0.5 \text{ V}$ to $V_{CC} - 0.5 \text{ V}$	
	Port 7	—	—	1.0	$\mu\text{A}$ $V_{in} = 0.5 \text{ V}$ to $AV_{CC} - 0.5 \text{ V}$		
Three-state leakage current	Ports 1 to 6 Ports 8 to B	$ I_{TSI} $	—	—	1.0	$\mu\text{A}$ $V_{in} = 0.5 \text{ V}$ to $V_{CC} - 0.5 \text{ V}$	
Input pull-up MOS current	Ports 2, 4, and 5	$-I_p$	50	—	300	$\mu\text{A}$ $V_{in} = 0 \text{ V}$	
Input capacitance	FWE	$C_{in}$	—	—	80	$\text{pF}$ $V_{in} = 0 \text{ V}$	
	NMI	—	—	—	50	$\text{pF}$ $f = 1 \text{ MHz}$	
	All input pins except NMI, and FWE	—	—	—	15	$\text{pF}$ $T_a = 25^\circ\text{C}$	
Current dissipation* <sup>2</sup>	Normal operation	$I_{CC}^{*3}$	—	55 (5.0 V)	100	$\text{mA}$ $f = 20 \text{ MHz}$	
	Sleep mode	—	—	40 (5.0 V)	73	$\text{mA}$ $f = 20 \text{ MHz}$	
	Module standby mode	—	—	24 (5.0 V)	51	$\text{mA}$ $f = 20 \text{ MHz}$	
	Standby mode	—	—	0.01	5.0	$\mu\text{A}$	$T_a = 50^\circ\text{C}$
		—	—	—	20.0	$\mu\text{A}$	$50^\circ\text{C}$ $T_a$
	Flash memory programming/erasing	—	—	60 (5.0 V)	110	$\text{mA}$	$0^\circ\text{C}$ $T_a = 85^\circ\text{C}$ $f = 20 \text{ MHz}$

**Table 21.11 DC Characteristics (1) (cont)**

Conditions:  $V_{CC} = 5.0 \text{ V} \pm 10\%$ ,  $AV_{CC} = 5.0 \text{ V} \pm 10\%$ ,  $V_{REF} = 4.5 \text{ V}$  to  $AV_{CC}^{*1}$ ,  
 $V_{SS} = AV_{SS} = 0 \text{ V}^{*1}$ ,  $T_a = -20^\circ\text{C}$  to  $+75^\circ\text{C}$  (regular specifications),  
 $T_a = -40^\circ\text{C}$  to  $+85^\circ\text{C}$  (wide-range specifications)  
 [Programming/erasing conditions:  $T_a = 0^\circ\text{C}$  to  $+75^\circ\text{C}$  (regular specifications),  
 $T_a = 0^\circ\text{C}$  to  $+85^\circ\text{C}$  (wide-range specifications)]

Item		Symbol	Min	Typ	Max	Unit	Test Conditions
Analog power supply current	During A/D conversion	$AI_{CC}$	—	0.6	1.5	mA	
	During A/D and D/A conversion		—	0.6	1.5	mA	
	Idle		—	0.01	5.0	$\mu\text{A}$	DASTE = 0
Reference current	During A/D conversion	$AI_{CC}$	—	0.5	0.8	mA	
	During A/D and D/A conversion		—	2.0	3.0	mA	
	Idle		—	0.01	5.0	$\mu\text{A}$	DASTE = 0
RAM standby voltage		$V_{RAM}$	2.0	—	—	V	

Notes: 1. Do not open the pin connections of the  $AV_{CC}$ ,  $V_{REF}$  and  $AV_{SS}$  pins while the A/D converter is not in use.

Connect the  $AV_{CC}$  and  $V_{REF}$  pins to the  $V_{CC}$  and connect the  $AV_{SS}$  pin to the  $V_{SS}$ , respectively.

2. Given current consumption values are when all the output pins are made to unloaded state and, furthermore, when the on-chip pull-up MOS is turned off under conditions that  $V_{IH \text{ min}} = V_{CC} - 0.5 \text{ V}$  and  $V_{IL \text{ max}} = 0.5 \text{ V}$ .

Also, the aforesaid current consumption values are when  $V_{IH \text{ min}} = V_{CC} \times 0.9$  and  $V_{IL \text{ max}} = 0.3 \text{ V}$  under the condition of  $V_{RAM} \ V_{CC} < 2.7 \text{ V}$ .

3.  $I_{CC \text{ max. (under normal operations)}} = 1.0 \text{ (mA)} + 0.90 \text{ (mA/(MHz} \times \text{V))} \times V_{CC} \times f$   
 $I_{CC \text{ max. (when using the sleeve)}} = 1.0 \text{ (mA)} + 0.65 \text{ (mA/(MHz} \times \text{V))} \times V_{CC} \times f$   
 $I_{CC \text{ max. (when the sleeve + module are standing by)}} = 1.0 \text{ (mA)} + 0.45 \text{ (mA/(MHz} \times \text{V))} \times V_{CC} \times f$

Also, the typ. values for current dissipation are reference values.



**Table 21.11 DC Characteristics (2)**

Conditions:  $V_{CC} = 3.0$  to  $5.5$  V,  $AV_{CC} = 3.0$  to  $5.5$  V,  $V_{REF} = 3.0$  V to  $AV_{CC}^{*1}$ ,  
 $V_{SS} = AV_{SS} = 0$  V<sup>\*1</sup>,  $T_a = -20^{\circ}\text{C}$  to  $+75^{\circ}\text{C}$  (regular specifications),  
 $T_a = -40^{\circ}\text{C}$  to  $+85^{\circ}\text{C}$  (wide-range specifications)  
 [Programming/erasing conditions:  $V_{CC} = 3.0$  to  $3.6$  V,  $T_a = 0$  to  $+75^{\circ}\text{C}$   
 (regular specifications),  $T_a = 0$  to  $+85^{\circ}\text{C}$  (wide-range specifications)]

Item	Symbol	Min	Typ	Max	Unit	Test Conditions
Schmitt trigger input voltages	Port A, P8 <sub>0</sub> to P8 <sub>2</sub>	$V_T^-$	$V_{CC} \times 0.2$	—	—	V
		$V_T^+$	—	—	$V_{CC} \times 0.7$	V
		$V_T^+ - V_T^-$	$V_{CC} \times 0.07$	—	—	V
Input high voltage	$\overline{\text{STBY}}$ , $\overline{\text{RES}}$ , NMI, MD <sub>2</sub> to MD <sub>0</sub> , FWE	$V_{IH}$	$V_{CC} \times 0.9$	—	$V_{CC} + 0.3$	V
	EXTAL		$V_{CC} \times 0.7$	—	$V_{CC} + 0.3$	V
	Port 7		$V_{CC} \times 0.7$	—	$AV_{CC} + 0.3$	V
	Ports 1 to 6 P8 <sub>3</sub> , P8 <sub>4</sub> , P9 <sub>0</sub> to P9 <sub>5</sub> , port B		$V_{CC} \times 0.7$	—	$V_{CC} + 0.3$	V
Input low voltage	$\overline{\text{STBY}}$ , $\overline{\text{RES}}$ , FWE, MD <sub>2</sub> to MD <sub>0</sub>	$V_{IL}$	-0.3	—	$V_{CC} \times 0.1$	V
	NMI, EXTAL, Ports 1 to 7		-0.3	—	$V_{CC} \times 0.2$	V $V_{CC} < 4.0$ V
	P8 <sub>3</sub> , P8 <sub>4</sub> , P9 <sub>0</sub> to P9 <sub>5</sub> , port B				0.8	V $V_{CC} = 4.0$ to $5.5$ V
Output high voltage	All output pins	$V_{OH}$	$V_{CC} - 0.5$	—	—	V $I_{OH} = -200$ $\mu\text{A}$
			$V_{CC} - 1.0$	—	—	V $I_{OH} = -1$ mA
Output low voltage	All output pins Ports 1, 2, and 5	$V_{OL}$	—	—	0.4	V $I_{OL} = 1.6$ mA
			—	—	1.0	V $I_{OL} = 5$ mA

**Table 21.11 DC Characteristics (2) (cont)**

Conditions:  $V_{CC} = 3.0$  to  $5.5$  V,  $AV_{CC} = 3.0$  to  $5.5$  V,  $V_{REF} = 3.0$  V to  $AV_{CC}^{*1}$ ,  
 $V_{SS} = AV_{SS} = 0$  V<sup>\*1</sup>,  $T_a = -20^{\circ}\text{C}$  to  $+75^{\circ}\text{C}$  (regular specifications),  
 $T_a = -40^{\circ}\text{C}$  to  $+85^{\circ}\text{C}$  (wide-range specifications)  
 [Programming/erasing conditions:  $V_{CC} = 3.0$  to  $3.6$  V,  $T_a = 0$  to  $+75^{\circ}\text{C}$   
 (regular specifications),  $T_a = 0$  to  $+85^{\circ}\text{C}$  (wide-range specifications)]

Item	Symbol	Min	Typ	Max	Unit	Test Conditions	
Input leakage current	STBY, RES, NMI, FWE, MD <sub>2</sub> to MD <sub>0</sub>	$ I_{in} $	—	—	1.0	$\mu\text{A}$	$V_{in} = 0.5$ V to $V_{CC} - 0.5$ V
	Port 7	—	—	1.0	$\mu\text{A}$	$V_{in} = 0.5$ V to $AV_{CC} - 0.5$ V	
Three-state leakage current	Ports 1 to 6 Ports 8 to B	$ I_{Tsi} $	—	—	1.0	$\mu\text{A}$	$V_{in} = 0.5$ V to $V_{CC} - 0.5$ V
Input pull-up MOS current	Ports 2, 4, and 5	$-I_p$	10	—	300	$\mu\text{A}$	$V_{in} = 0$ V
Input capacitance	FWE	$C_{in}$	—	—	80	pF	$V_{in} = 0$ V
	NMI	—	—	—	50	pF	$f = 1$ MHz
	All input pins except NMI, and FWE	—	—	—	15	pF	$T_a = 25^{\circ}\text{C}$
Current dissipation <sup>*2</sup>	Normal operation	$I_{CC}^{*3}$	—	28 (3.5 V)	66	$\text{mA}$	$f = 13$ MHz
	Sleep mode	—	—	20 (3.5 V)	48	$\text{mA}$	$f = 13$ MHz
	Module standby mode	—	—	13 (3.5 V)	34	$\text{mA}$	$f = 13$ MHz
	Standby mode	—	—	0.01	5.0	$\mu\text{A}$	$T_a = 50^{\circ}\text{C}$
		—	—	—	20.0	$\mu\text{A}$	$50^{\circ}\text{C}$ $T_a$
	Flash memory programming/erasing	—	—	33 (3.5 V)	76	$\text{mA}$	$0^{\circ}\text{C}$ $T_a$ $85^{\circ}\text{C}$ $f = 13$ MHz

**Table 21.11 DC Characteristics (2) (cont)**

Conditions:  $V_{CC} = 3.0$  to  $5.5$  V,  $AV_{CC} = 3.0$  to  $5.5$  V,  $V_{REF} = 3.0$  V to  $AV_{CC}^{*1}$ ,  
 $V_{SS} = AV_{SS} = 0$  V<sup>\*1</sup>,  $T_a = -20^{\circ}\text{C}$  to  $+75^{\circ}\text{C}$  (regular specifications),  
 $T_a = -40^{\circ}\text{C}$  to  $+85^{\circ}\text{C}$  (wide-range specifications)  
 [Programming/erasing conditions:  $V_{CC} = 3.0$  to  $3.6$  V,  $T_a = 0$  to  $+75^{\circ}\text{C}$   
 (regular specifications),  $T_a = 0$  to  $+85^{\circ}\text{C}$  (wide-range specifications)]

Item		Symbol	Min	Typ	Max	Unit	Test Conditions
Analog power supply current	During A/D conversion	$AI_{CC}$	—	0.2	0.5	mA	$AV_{CC} = 3.0$ V
	During A/D and D/A conversion		—	0.2	0.5	mA	$AV_{CC} = 3.0$ V
	Idle		—	0.01	5.0	$\mu\text{A}$	DASTE = 0
Reference current	During A/D conversion	$AI_{CC}$	—	0.3	0.5	mA	$V_{REF} = 3.0$ V
	During A/D and D/A conversion		—	1.2	2.0	mA	$V_{REF} = 3.0$ V
	Idle		—	0.01	5.0	$\mu\text{A}$	DASTE = 0
RAM standby voltage		$V_{RAM}$	2.0	—	—	V	

Notes: 1. Do not open the pin connections of the  $AV_{CC}$ ,  $V_{REF}$  and  $AV_{SS}$  pins while the A/D converter is not in use.

Connect the  $AV_{CC}$  and  $V_{REF}$  pins to the  $V_{CC}$  and connect the  $AV_{SS}$  pin to the  $V_{SS}$ , respectively.

2. Given current consumption values are when all the output pins are made to unloaded state and, furthermore, when the on-chip pull-up MOS is turned off under conditions that  $V_{IH\ min} = V_{CC} - 0.5$  V and  $V_{IL\ max} = 0.5$  V.

Also, the aforesaid current consumption values are when  $V_{IH\ min} = V_{CC} \times 0.9$  and  $V_{IL\ max} = 0.3$  V under the condition of  $V_{RAM} \ V_{CC} < 3.0$  V.

3.  $I_{CC\ max.}$  (under normal operations) =  $1.0$  (mA) +  $0.90$  (mA/(MHz  $\times$  V))  $\times V_{CC} \times f$   
 $I_{CC\ max.}$  (when using the sleeve) =  $1.0$  (mA) +  $0.65$  (mA/(MHz  $\times$  V))  $\times V_{CC} \times f$   
 $I_{CC\ max.}$  (when the sleeve + module are standing by)  
 =  $1.0$  (mA) +  $0.45$  (mA/(MHz  $\times$  V))  $\times V_{CC} \times f$

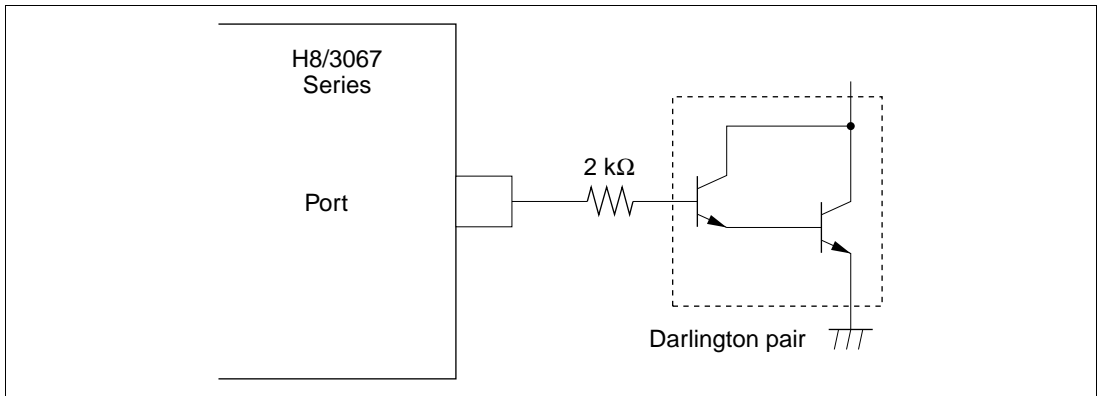
Also, the typ. values for current dissipation are reference values.

## Table 21.12 Permissible Output Currents

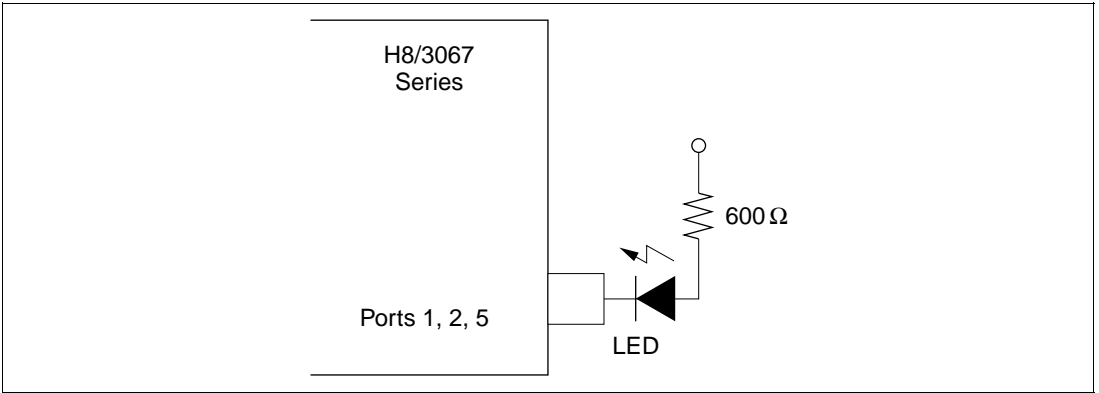
Conditions:  $V_{CC} = 3.0\text{ V to }5.5\text{ V}$ ,  $AV_{CC} = 3.0\text{ V to }5.5\text{ V}$ ,  $V_{REF} = 3.0\text{ V to }AV_{CC}$ ,  
 $V_{SS} = AV_{SS} = 0\text{ V}$ ,  $T_a = -20^\circ\text{C to }+75^\circ\text{C}$  (regular specifications),  
 $T_a = -40^\circ\text{C to }+85^\circ\text{C}$  (wide-range specifications)

Item		Symbol	Min	Typ	Max	Unit
Permissible output low current (per pin)	Ports 1, 2, and 5	$I_{OL}$	—	—	10	mA
	Other output pins		—	—	2.0	mA
Permissible output low current (total)	Sum of 20 pins in ports 1, 2, and 5	$\Sigma I_{OL}$	—	—	80	mA
	Total of all output pins, including the above		—	—	120	mA
Permissible output high current (per pin)	All output pins	$ -I_{OH} $	—	—	2.0	mA
Permissible output high current (total)	Total of all output pins	$ \Sigma I_{OH} $	—	—	40	mA

- Notes: 1. To protect chip reliability, do not exceed the output current values in table 21.12.  
2. When driving a darlington pair, always insert a current-limiting resistor in the output line, as shown in figures 21.4 and 21.5.



**Figure 21.4 Darlington Pair Drive Circuit (Example)**



**Figure 21.5 Sample LED Circuit**

### 21.2.3 AC Characteristics

Clock timing parameters are listed in table 21.13, control signal timing parameters in table 21.14, and bus timing parameters in table 21.15. Timing parameters of the on-chip supporting modules are listed in table 21.16.

**Table 21.13 Clock Timing**

Condition:  $T_a = -20^{\circ}\text{C}$  to  $+75^{\circ}\text{C}$  (regular specifications),  $T_a = -40^{\circ}\text{C}$  to  $+85^{\circ}\text{C}$  (wide-range specifications)

Condition A:  $V_{CC} = 3.0$  to  $5.5$  V,  $AV_{CC} = 3.0$  to  $5.5$  V,  $V_{REF} = 3.0$  to  $AV_{CC}$ ,  $V_{SS} = AV_{SS} = 0$  V,  $f_{max} = 13$  MHz

Condition B:  $V_{CC} = 5.0$  V  $\pm$  10%,  $AV_{CC} = 5.0$  V  $\pm$  10%,  $V_{REF} = 4.5$  to  $AV_{CC}$ ,  $V_{SS} = AV_{SS} = 0$  V,  $f_{max} = 20$  MHz

Item	Symbol	Condition				Unit	Test Conditions
		A		B			
		Min	Max	Min	Max		
Clock cycle time	$t_{cyc}$	76.9	1000	50	1000	ns	Figure 21.11
Clock pulse low width	$t_{CL}$	18	—	15	—	ns	
Clock pulse high width	$t_{CH}$	18	—	15	—	ns	
Clock rise time	$t_{Cr}$	—	15	—	10	ns	
Clock fall time	$t_{Cf}$	—	15	—	10	ns	
Clock oscillator settling time at reset	$t_{OSC1}$	20	—	20	—	ms	Figure 21.7
Clock oscillator settling time in software standby	$t_{OSC2}$	7	—	7	—	ms	Figure 20.1

## Table 21.14 Control Signal Timing

Condition:  $T_a = -20^{\circ}\text{C}$  to  $+75^{\circ}\text{C}$  (regular specifications),  $T_a = -40^{\circ}\text{C}$  to  $+85^{\circ}\text{C}$  (wide-range specifications)

Condition A:  $V_{CC} = 3.0$  to  $5.5$  V,  $AV_{CC} = 3.0$  to  $5.5$  V,  $V_{REF} = 3.0$  to  $AV_{CC}$ ,  $V_{SS} = AV_{SS} = 0$  V,  $f_{max} = 13$  MHz

Condition B:  $V_{CC} = 5.0$  V  $\pm$  10%,  $AV_{CC} = 5.0$  V  $\pm$  10%,  $V_{REF} = 4.5$  to  $AV_{CC}$ ,  $V_{SS} = AV_{SS} = 0$  V,  $f_{max} = 20$  MHz

Item	Symbol	Condition				Unit	Test Conditions
		A		B			
		Min	Max	Min	Max		
$\overline{\text{RES}}$ setup time	$t_{\text{RESS}}$	200	—	150	—	ns	Figure 21.8
$\overline{\text{RES}}$ pulse width	$t_{\text{RESW}}$	20	—	20	—	$t_{\text{cyc}}$	
Mode programming setup time	$t_{\text{MDS}}$	200	—	200	—	ns	
NMI, $\overline{\text{IRQ}}$ setup time	$t_{\text{NMIS}}$	200	—	150	—	ns	Figure 21.10
NMI, $\overline{\text{IRQ}}$ hold time	$t_{\text{NMIH}}$	10	—	10	—	ns	
NMI, $\overline{\text{IRQ}}$ pulse width	$t_{\text{NMIW}}$	200	—	200	—	ns	

**Table 21.15 Bus Timing**

Condition:  $T_a = -20^{\circ}\text{C}$  to  $+75^{\circ}\text{C}$  (regular specifications),  $T_a = -40^{\circ}\text{C}$  to  $+85^{\circ}\text{C}$  (wide-range specifications)

Condition A:  $V_{CC} = 3.0$  to  $5.5$  V,  $AV_{CC} = 3.0$  to  $5.5$  V,  $V_{REF} = 3.0$  to  $AV_{CC}$ ,  $V_{SS} = AV_{SS} = 0$  V,  $f_{max} = 13$  MHz

Condition B:  $V_{CC} = 5.0$  V  $\pm$  10%,  $AV_{CC} = 5.0$  V  $\pm$  10%,  $V_{REF} = 4.5$  to  $AV_{CC}$ ,  $V_{SS} = AV_{SS} = 0$  V,  $f_{max} = 20$  MHz

Item	Symbol	Condition				Unit	Test Conditions
		A		B			
		Min	Max	Min	Max		
Address delay time	$t_{AD}$	—	40	—	25	ns	Figure 21.11, figure 21.12, figure 21.14, figure 21.15, figure 21.17
Address hold time	$t_{AH}$	$0.5 t_{cyc} - 35$	—	$0.5 t_{cyc} - 20$	—	ns	
Read strobe delay time	$t_{RSD}$	—	50	—	25	ns	
Address strobe delay time	$t_{ASD}$	—	50	—	25	ns	
Write strobe delay time	$t_{WSD}$	—	50	—	25	ns	
Strobe delay time	$t_{SD}$	—	50	—	25	ns	
Write strobe pulse width 1	$t_{WSW1}$	$1.0 t_{cyc} - 40$	—	$1.0 t_{cyc} - 25$	—	ns	
Write strobe pulse width 2	$t_{WSW2}$	$1.5 t_{cyc} - 40$	—	$1.5 t_{cyc} - 25$	—	ns	
Address setup time 1	$t_{AS1}$	$0.5 t_{cyc} - 29$	—	$0.5 t_{cyc} - 20$	—	ns	
Address setup time 2	$t_{AS2}$	$1.0 t_{cyc} - 35$	—	$1.0 t_{cyc} - 20$	—	ns	
Read data setup time	$t_{RDS}$	40	—	25	—	ns	
Read data hold time	$t_{RDH}$	0	—	0	—	ns	



**Table 21.15 Bus Timing (cont)**

Condition:  $T_a = -20^{\circ}\text{C}$  to  $+75^{\circ}\text{C}$  (regular specifications),  $T_a = -40^{\circ}\text{C}$  to  $+85^{\circ}\text{C}$  (wide-range specifications)

Condition A:  $V_{CC} = 3.0$  to  $5.5$  V,  $AV_{CC} = 3.0$  to  $5.5$  V,  $V_{REF} = 3.0$  to  $AV_{CC}$ ,  $V_{SS} = AV_{SS} = 0$  V,  $f_{max} = 13$  MHz

Condition B:  $V_{CC} = 5.0$  V  $\pm$  10%,  $AV_{CC} = 5.0$  V  $\pm$  10%,  $V_{REF} = 4.5$  to  $AV_{CC}$ ,  $V_{SS} = AV_{SS} = 0$  V,  $f_{max} = 20$  MHz

Item	Symbol	Condition				Unit	Test Conditions
		A		B			
		Min	Max	Min	Max		
Write data delay time	$t_{WDD}$	—	50	—	35	ns	Figure 21.11, figure 21.12, figure 21.14, figure 21.15, figure 21.17
Write data setup time 1	$t_{WDS1}$	$1.0 t_{cyc}$ – 40	—	$1.0 t_{cyc}$ – 30	—	ns	
Write data setup time 2	$t_{WDS2}$	$2.0 t_{cyc}$ – 40	—	$2.0 t_{cyc}$ – 30	—	ns	
Write data hold time	$t_{WDH}$	$0.5 t_{cyc}$ – 25	—	$0.5 t_{cyc}$ – 15	—	ns	
Read data access time 1	$t_{ACC1}$	—	$2.0 t_{cyc}$ – 80	—	$2.0 t_{cyc}$ – 45	ns	
Read data access time 2	$t_{ACC2}$	—	$3.0 t_{cyc}$ – 80	—	$3.0 t_{cyc}$ – 45	ns	
Read data access time 3	$t_{ACC3}$	—	$1.5 t_{cyc}$ – 80	—	$1.5 t_{cyc}$ – 45	ns	
Read data access time 4	$t_{ACC4}$	—	$2.5 t_{cyc}$ – 80	—	$2.5 t_{cyc}$ – 45	ns	
Precharge time 1	$t_{PCH1}$	$1.0 t_{cyc}$ – 30	—	$1.0 t_{cyc}$ – 20	—	ns	
Precharge time 2	$t_{PCH2}$	$0.5 t_{cyc}$ – 30	—	$0.5 t_{cyc}$ – 20	—	ns	
Wait setup time	$t_{WTS}$	40	—	25	—	ns	Figure 21.13
Wait hold time	$t_{WTH}$	5	—	5	—	ns	
Bus request setup time	$t_{BRQS}$	40	—	25	—	ns	Figure 21.16
Bus acknowledge delay time 1	$t_{BACD1}$	—	50	—	30	ns	
Bus acknowledge delay time 2	$t_{BACD2}$	—	50	—	30	ns	

**Table 21.15 Bus Timing (cont)**

Condition:  $T_a = -20^{\circ}\text{C}$  to  $+75^{\circ}\text{C}$  (regular specifications),  $T_a = -40^{\circ}\text{C}$  to  $+85^{\circ}\text{C}$  (wide-range specifications)

Condition A:  $V_{CC} = 3.0$  to  $5.5$  V,  $AV_{CC} = 3.0$  to  $5.5$  V,  $V_{REF} = 3.0$  to  $AV_{CC}$ ,  $V_{SS} = AV_{SS} = 0$  V,  $f_{max} = 13$  MHz

Condition B:  $V_{CC} = 5.0$  V  $\pm$  10%,  $AV_{CC} = 5.0$  V  $\pm$  10%,  $V_{REF} = 4.5$  to  $AV_{CC}$ ,  $V_{SS} = AV_{SS} = 0$  V,  $f_{max} = 20$  MHz

Item	Symbol	Condition				Unit	Test Conditions
		A		B			
		Min	Max	Min	Max		
Bus-floating time	$t_{BZD}$	—	50	—	30	ns	Figure 21.16
$\overline{\text{RAS}}$ precharge time	$t_{RP}$	$1.5 t_{cyc}$ – 40	—	$1.5 t_{cyc}$ – 25	—	ns	Figure 21.17 to figure 21.19
$\overline{\text{CAS}}$ precharge time	$t_{CP}$	$0.5 t_{cyc}$ – 25	—	$0.5 t_{cyc}$ – 15	—	ns	
Low address hold time	$t_{RAH}$	$0.5 t_{cyc}$ – 25	—	$0.5 t_{cyc}$ – 15	—	ns	
$\overline{\text{RAS}}$ delay time 1	$t_{RAD1}$	—	50	—	25	ns	
$\overline{\text{RAS}}$ delay time 2	$t_{RAD2}$	—	50	—	30	ns	
$\overline{\text{CAS}}$ delay time 1	$t_{CASD1}$	—	50	—	25	ns	
$\overline{\text{CAS}}$ delay time 2	$t_{CASD2}$	—	50	—	25	ns	
$\overline{\text{WE}}$ delay time	$t_{WCD}$	—	50	—	25	ns	
$\overline{\text{CAS}}$ pulse width 1	$t_{CAS1}$	$1.5 t_{cyc}$ – 40	—	$1.5 t_{cyc}$ – 20	—	ns	
$\overline{\text{CAS}}$ pulse width 2	$t_{CAS2}$	$1.0 t_{cyc}$ – 40	—	$1.0 t_{cyc}$ – 20	—	ns	
$\overline{\text{CAS}}$ pulse width 3	$t_{CAS3}$	$1.0 t_{cyc}$ – 40	—	$1.0 t_{cyc}$ – 20	—	ns	
$\overline{\text{RAS}}$ access time	$t_{RAC}$	—	$2.5 t_{cyc}$ – 70	—	$2.5 t_{cyc}$ – 40	ns	
Address access time	$t_{AA}$	—	$2.0 t_{cyc}$ – 80	—	$2.0 t_{cyc}$ – 50	ns	
$\overline{\text{CAS}}$ access time	$t_{CAC}$	—	$1.5 t_{cyc}$ – 80	—	$1.5 t_{cyc}$ – 50	ns	
$\overline{\text{WE}}$ setup time	$t_{WCS}$	$0.5 t_{cyc}$ – 35	—	$0.5 t_{cyc}$ – 20	—	ns	

**Table 21.15 Bus Timing (cont)**

Condition:  $T_a = -20^{\circ}\text{C}$  to  $+75^{\circ}\text{C}$  (regular specifications),  $T_a = -40^{\circ}\text{C}$  to  $+85^{\circ}\text{C}$  (wide-range specifications)

Condition A:  $V_{CC} = 3.0$  to  $5.5$  V,  $AV_{CC} = 3.0$  to  $5.5$  V,  $V_{REF} = 3.0$  to  $AV_{CC}$ ,  $V_{SS} = AV_{SS} = 0$  V,  $f_{max} = 13$  MHz

Condition B:  $V_{CC} = 5.0$  V  $\pm 10\%$ ,  $AV_{CC} = 5.0$  V  $\pm 10\%$ ,  $V_{REF} = 4.5$  to  $AV_{CC}$ ,  $V_{SS} = AV_{SS} = 0$  V,  $f_{max} = 20$  MHz

Item	Symbol	Condition				Unit	Test Conditions
		A		B			
		Min	Max	Min	Max		
$\overline{WE}$ hold time	$t_{WCH}$	$0.5 t_{cyc}$ - 28	—	$0.5 t_{cyc}$ - 15	—	ns	Figure 21.17 to figure 21.19
Write data setup time	$t_{WDS}$	$0.5 t_{cyc}$ - 35	—	$0.5 t_{cyc}$ - 20	—	ns	
$\overline{WE}$ write data hold time	$t_{WDH}$	$0.5 t_{cyc}$ - 25	—	$0.5 t_{cyc}$ - 15	—	ns	
$\overline{CAS}$ setup time 1	$t_{CSR1}$	$0.5 t_{cyc}$ - 25	—	$0.5 t_{cyc}$ - 20	—	ns	
$\overline{CAS}$ setup time 2	$t_{CSR2}$	$0.5 t_{cyc}$ - 25	—	$0.5 t_{cyc}$ - 15	—	ns	
$\overline{CAS}$ hold time	$t_{CHR}$	$0.5 t_{cyc}$ - 25	—	$0.5 t_{cyc}$ - 15	—	ns	
$\overline{RAS}$ pulse width	$t_{RAS}$	$1.5 t_{cyc}$ - 25	—	$1.5 t_{cyc}$ - 15	—	ns	

**Table 21.16 Timing of On-Chip Supporting Modules**

Condition:  $T_a = -20^{\circ}\text{C}$  to  $+75^{\circ}\text{C}$  (regular specifications),  $T_a = -40^{\circ}\text{C}$  to  $+85^{\circ}\text{C}$  (wide-range specifications)

Condition A:  $V_{CC} = 3.0$  to  $5.5$  V,  $AV_{CC} = 3.0$  to  $5.5$  V,  $V_{REF} = 3.0$  to  $AV_{CC}$ ,  $V_{SS} = AV_{SS} = 0$  V,  $f_{max} = 13$  MHz

Condition B:  $V_{CC} = 5.0$  V  $\pm$  10%,  $AV_{CC} = 5.0$  V  $\pm$  10%,  $V_{REF} = 4.5$  to  $AV_{CC}$ ,  $V_{SS} = AV_{SS} = 0$  V,  $f_{max} = 20$  MHz

Item	Symbol	Condition				Unit	Test Conditions		
		A		B					
		Min	Max	Min	Max				
Port/ TPC	Output data delay time	$t_{PWD}$	—	100	—	50	ns	Figure 21.20	
	Input data setup time	$t_{PRS}$	50	—	50	—	ns		
	Input data hold time	$t_{PRH}$	50	—	50	—	ns		
16-bit timer	Timer output delay time	$t_{TOCD}$	—	100	—	50	ns	Figure 21.21	
	Timer input setup time	$t_{TICS}$	50	—	50	—	ns		
	Timer clock input setup time	$t_{TCKS}$	50	—	50	—	ns	Figure 21.22	
	Timer clock pulse width	Single edge	$t_{TCKWH}$	1.5	—	1.5	—		$t_{cyc}$
		Both edges	$t_{TCKWL}$	2.5	—	2.5	—		$t_{cyc}$
8-bit timer	Timer output delay time	$t_{TOCD}$	—	100	—	50	ns	Figure 21.21	
	Timer input setup time	$t_{TICS}$	50	—	50	—	ns		
	Timer clock input setup time	$t_{TCKS}$	50	—	50	—	ns	Figure 21.22	
	Timer clock pulse width	Single edge	$t_{TCKWH}$	1.5	—	1.5	—		$t_{cyc}$
		Both edges	$t_{TCKWL}$	2.5	—	2.5	—		$t_{cyc}$

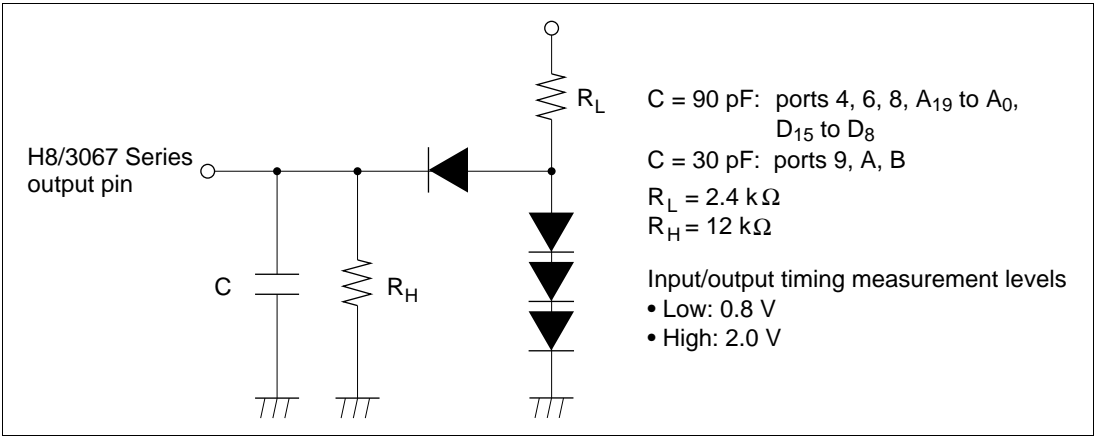
**Table 21.16 Timing of On-Chip Supporting Modules (cont)**

Condition:  $T_a = -20^{\circ}\text{C}$  to  $+75^{\circ}\text{C}$  (regular specifications),  $T_a = -40^{\circ}\text{C}$  to  $+85^{\circ}\text{C}$  (wide-range specifications)

Condition A:  $V_{CC} = 3.0$  to  $5.5$  V,  $AV_{CC} = 3.0$  to  $5.5$  V,  $V_{REF} = 3.0$  to  $AV_{CC}$ ,  $V_{SS} = AV_{SS} = 0$  V,  $f_{max} = 13$  MHz

Condition B:  $V_{CC} = 5.0$  V  $\pm 10\%$ ,  $AV_{CC} = 5.0$  V  $\pm 10\%$ ,  $V_{REF} = 4.5$  to  $AV_{CC}$ ,  $V_{SS} = AV_{SS} = 0$  V,  $f_{max} = 20$  MHz

Item			Symbol	Condition				Unit	Test Conditions	
				A		B				
				Min	Max	Min	Max			
SCI	Input clock cycle	Asynchronous	$t_{S_{cyc}}$	4	—	4	—	$t_{cyc}$	Figure 21.23	
		Synchronous		6	—	6	—	$t_{cyc}$		
	Input clock rise time		$t_{S_{CKr}}$	1.5	—	1.5	—	$t_{cyc}$		
	Input clock fall time		$t_{S_{CKf}}$	1.5	—	1.5	—	$t_{cyc}$		
	Input clock pulse width		$t_{S_{CKW}}$	0.4	0.6	0.4	0.6	$t_{S_{cyc}}$		
	Transmit data delay time		$t_{TXD}$	—	100	—	100	ns		Figure 21.24
	Receive data setup time (synchronous)		$t_{RXS}$	100	—	100	—	ns		
	Receive data hold time (synchronous)	Clock input	$t_{RXH}$	100	—	100	—	ns		
Clock output			0	—	0	—	ns			
DMAC	$\overline{TEND}$ delay time 1		$t_{TED1}$	—	100	—	50	ns	Figure 21.25, figure 21.26	
	$\overline{TEND}$ delay time 2		$t_{TED2}$	—	100	—	50	ns		
	$\overline{DREQ}$ setup time		$t_{DRQS}$	40	—	25	—	ns	Figure 21.27	
	$\overline{DREQ}$ hold time		$t_{DRQH}$	10	—	10	—	ns		



**Figure 21.6 Output Load Circuit**

## 21.2.4 A/D Conversion Characteristics

Table 21.17 lists the A/D conversion characteristics.

**Table 21.17 A/D Conversion Characteristics**

Condition:  $T_a = -20^\circ\text{C}$  to  $+75^\circ\text{C}$  (regular specifications),  $T_a = -40^\circ\text{C}$  to  $+85^\circ\text{C}$  (wide-range specifications)

Condition A:  $V_{CC} = 3.0$  to  $5.5$  V,  $AV_{CC} = 3.0$  to  $5.5$  V,  $V_{REF} = 3.0$  to  $AV_{CC}$ ,  $V_{SS} = AV_{SS} = 0$  V,  $f_{max} = 13$  MHz

Condition B:  $V_{CC} = 5.0$  V  $\pm 10\%$ ,  $AV_{CC} = 5.0$  V  $\pm 10\%$ ,  $V_{REF} = 4.5$  to  $AV_{CC}$ ,  $V_{SS} = AV_{SS} = 0$  V,  $f_{max} = 20$  MHz

Item		Condition						Unit	
		A			B				
		Min	Typ	Max	Min	Typ	Max		
Conversion time: 134 states	Resolution	10	10	10	10	10	10	bits	
	Conversion time (single mode)	—	—	134	—	—	134	$t_{cyc}$	
	Analog input capacitance	—	—	20	—	—	20	pF	
	Permissible signal-source impedance	$\phi$ 13 MHz	—	—	—	—	—	10	k
		$\phi > 13$ MHz	—	—	—	—	—	5	k
		4.0 V $AV_{CC}$ 5.5 V	—	—	10	—	—	—	k
		3.0 V $AV_{CC}$ < 4.0 V	—	—	5	—	—	—	k
	Nonlinearity error	—	—	$\pm 7.5$	—	—	$\pm 3.5$	LSB	
	Offset error	—	—	$\pm 7.5$	—	—	$\pm 3.5$	LSB	
	Full-scale error	—	—	$\pm 7.5$	—	—	$\pm 3.5$	LSB	
	Quantization error	—	—	$\pm 0.5$	—	—	$\pm 0.5$	LSB	
Absolute accuracy	—	—	$\pm 8.0$	—	—	$\pm 4.0$	LSB		

**Table 21.17 A/D Conversion Characteristics (cont)**

Condition:  $T_a = -20^{\circ}\text{C}$  to  $+75^{\circ}\text{C}$  (regular specifications),  $T_a = -40^{\circ}\text{C}$  to  $+85^{\circ}\text{C}$  (wide-range specifications)

Condition A:  $V_{CC} = 3.0$  to  $5.5$  V,  $AV_{CC} = 3.0$  to  $5.5$  V,  $V_{REF} = 3.0$  to  $AV_{CC}$ ,  $V_{SS} = AV_{SS} = 0$  V,  $f_{max} = 13$  MHz

Condition B:  $V_{CC} = 5.0$  V  $\pm 10\%$ ,  $AV_{CC} = 5.0$  V  $\pm 10\%$ ,  $V_{REF} = 4.5$  to  $AV_{CC}$ ,  $V_{SS} = AV_{SS} = 0$  V,  $f_{max} = 20$  MHz

Item		Condition						Unit	
		A			B				
		Min	Typ	Max	Min	Typ	Max		
Conversion time: 70 states	Resolution	10	10	10	10	10	10	bits	
	Conversion time (single mode)	—	—	70	—	—	70	$t_{cyc}$	
	Analog input capacitance	—	—	20	—	—	20	pF	
	Permissible signal-source impedance	$\phi$ 13 MHz	—	—	—	—	—	5	k
		$\phi > 13$ MHz	—	—	—	—	—	3	k
		4.0 V $AV_{CC}$ 5.5 V	—	—	5	—	—	—	k
		3.0 V $AV_{CC}$ < 4.0 V	—	—	3	—	—	—	k
	Nonlinearity error	—	—	$\pm 15.5$	—	—	$\pm 7.5$	LSB	
	Offset error	—	—	$\pm 15.5$	—	—	$\pm 7.5$	LSB	
	Full-scale error	—	—	$\pm 15.5$	—	—	$\pm 7.5$	LSB	
Quantization error	—	—	$\pm 0.5$	—	—	$\pm 0.5$	LSB		
Absolute accuracy	—	—	$\pm 16$	—	—	$\pm 8.0$	LSB		



## 21.2.5 D/A Conversion Characteristics

Table 21.18 lists the D/A conversion characteristics.

**Table 21.18 D/A Conversion Characteristics**

Condition:  $T_a = -20^{\circ}\text{C}$  to  $+75^{\circ}\text{C}$  (regular specifications),  $T_a = -40^{\circ}\text{C}$  to  $+85^{\circ}\text{C}$  (wide-range specifications)

Condition A:  $V_{CC} = 3.0$  to  $5.5$  V,  $AV_{CC} = 3.0$  to  $5.5$  V,  $V_{REF} = 3.0$  to  $AV_{CC}$ ,  $V_{SS} = AV_{SS} = 0$  V,  $f_{max} = 13$  MHz

Condition B:  $V_{CC} = 5.0$  V  $\pm$  10%,  $AV_{CC} = 5.0$  V  $\pm$  10%,  $V_{REF} = 4.5$  to  $AV_{CC}$ ,  $V_{SS} = AV_{SS} = 0$  V,  $f_{max} = 20$  MHz

Item	Condition						Unit	Test Conditions
	A			B				
	Min	Typ	Max	Min	Typ	Max		
Resolution	8	8	8	8	8	8	bits	
Conversion time (centering— time)	—	—	10	—	—	10	$\mu\text{s}$	20 pF capacitive load
Absolute accuracy	—	$\pm 2.0$	$\pm 3.0$	—	$\pm 1.5$	$\pm 2.0$	LSB	2 M resistive load
	—	—	$\pm 2.0$	—	—	$\pm 1.5$	LSB	4 M resistive load

## 21.2.6 Flash Memory Characteristics

Table 21.19 shows the flash memory characteristics.

**Table 21.19 Flash Memory Characteristics (1)**

Conditions:  $V_{CC}=4.5$  to  $5.5V$ ,  $AV_{CC}=4.5$  to  $5.5V$ ,  $V_{SS}=AV_{SS}=0V$   
 $T_a=0$  to  $+75^{\circ}C$  (Programming/erasing operating temperature range: regular specification)  
 $T_a=0$  to  $+85^{\circ}C$  (Programming/erasing operating temperature range: wide-range specification)

Item	Symbol	Min	Typ	Max	Unit	Test Condition
Programming time*1,*2,*4	$t_p$	—	10	200	ms/32 bytes	
Erase time*1,*3,*5	$t_E$	—	100	1200	ms/block	
Reprogramming count	$N_{WEC}$	—	—	100	Times	
Programming	Wait time after SWE bit setting*1	x	10	—	—	$\mu s$
	Wait time after PSU bit setting*1	y	50	—	—	$\mu s$
	Wait time after P bit setting*1,*4	z	150	—	500	$\mu s$
	Wait time after P bit clear*1	$\alpha$	10	—	—	$\mu s$
	Wait time after PSU bit clear*1	$\beta$	10	—	—	$\mu s$
	Wait time after PV bit setting*1	$\gamma$	4	—	—	$\mu s$
	Wait time after H'FF dummy write*1	$\epsilon$	2	—	—	$\mu s$
	Wait time after PV bit clear*1	$\eta$	4	—	—	$\mu s$
	Maximum programming count*1,*4	N	—	—	403	Times
Erase	Wait time after SWE bit setting*1	x	10	—	—	$\mu s$
	Wait time after ESU bit setting*1	y	200	—	—	$\mu s$
	Wait time after E bit setting*1,*5	z	5	—	10	ms
	Wait time after E bit clear*1	$\alpha$	10	—	—	$\mu s$
	Wait time after ESU bit clear*1	$\beta$	10	—	—	$\mu s$
	Wait time after EV bit setting*1	$\gamma$	20	—	—	$\mu s$
	Wait time after H'FF dummy write*1	$\epsilon$	2	—	—	$\mu s$
	Wait time after EV bit clear*1	$\eta$	5	—	—	$\mu s$
	Maximum erase count*1,*5	N	120	—	240	Times

- Notes:
1. Make each time setting in accordance with the program/program-verify flowchart or erase/erase-verify flowchart.
  2. Programming time per 32 bytes (Shows the total period for which the P-bit in the flash memory control register (FLMCR) is set. It does not include the programming verification time.)
  3. Block erase time (Shows the total period for which the E-bit in FLMCR is set. It does not include the erase verification time.)
  4. To specify the maximum programming time ( $t_p(\max)$ ) in the 32-byte programming flowchart, set the maximum value (403) for the maximum programming count (N).  
 The wait time after P bit setting (z) should be changed as follows according to the programming counter value.  
 Programming counter value of 1 to 4 :  $z = 150 \mu s$   
 Programming counter value of 5 to 403 :  $z = 500 \mu s$
  5. For the maximum erase time ( $t_E(\max)$ ), the following relationship applies between the wait time after E bit setting (z) and the maximum erase count (N):  
 $t_E(\max) = \text{Wait time after E bit setting (z)} \times \text{maximum erase count (N)}$   
 To set the maximum erase time, the values of z and N should be set so as to satisfy the above formula.  
 Examples: When z = 5 [ms], N = 240 times  
 When z = 10 [ms], N = 120 times

**Table 21.19 Flash Memory Characteristics (2)**

Conditions:  $V_{CC}=3.0$  to  $3.6$  V,  $AV_{CC}=3.0$  to  $3.6$  V,  $V_{SS}=AV_{SS}=0$ V  
 $T_a=0$  to  $+75^{\circ}\text{C}$  (Programming/erasing operating temperature range: regular specification)  
 $T_a=0$  to  $+85^{\circ}\text{C}$  (Programming/erasing operating temperature range: wide-range specification)

Item	Symbol	Min	Typ	Max	Unit	Test Condition
Programming time* <sup>1,*2,*4</sup>	$t_p$	—	10	200	ms/32 bytes	
Erase time* <sup>1,*3,*5</sup>	$t_E$	—	100	1200	ms/block	
Reprogramming count	$N_{WEC}$	—	—	100	Times	
Programming	Wait time after SWE bit setting* <sup>1</sup>	x	10	—	—	$\mu\text{s}$
	Wait time after PSU bit setting* <sup>1</sup>	y	50	—	—	$\mu\text{s}$
	Wait time after P bit setting* <sup>1,*4</sup>	z	150	—	500	$\mu\text{s}$
	Wait time after P bit clear* <sup>1</sup>	$\alpha$	10	—	—	$\mu\text{s}$
	Wait time after PSU bit clear* <sup>1</sup>	$\beta$	10	—	—	$\mu\text{s}$
	Wait time after PV bit setting* <sup>1</sup>	$\gamma$	4	—	—	$\mu\text{s}$
	Wait time after H'FF dummy write* <sup>1</sup>	$\varepsilon$	2	—	—	$\mu\text{s}$
	Wait time after PV bit clear* <sup>1</sup>	$\eta$	4	—	—	$\mu\text{s}$
	Maximum programming count* <sup>1,*4</sup>	N	—	—	403	Times
Erase	Wait time after SWE bit setting* <sup>1</sup>	x	10	—	—	$\mu\text{s}$
	Wait time after ESU bit setting* <sup>1</sup>	y	200	—	—	$\mu\text{s}$
	Wait time after E bit setting* <sup>1,*5</sup>	z	5	—	10	ms
	Wait time after E bit clear* <sup>1</sup>	$\alpha$	10	—	—	$\mu\text{s}$
	Wait time after ESU bit clear* <sup>1</sup>	$\beta$	10	—	—	$\mu\text{s}$
	Wait time after EV bit setting* <sup>1</sup>	$\gamma$	20	—	—	$\mu\text{s}$
	Wait time after H'FF dummy write* <sup>1</sup>	$\varepsilon$	2	—	—	$\mu\text{s}$
	Wait time after EV bit clear* <sup>1</sup>	$\eta$	5	—	—	$\mu\text{s}$
	Maximum erase count* <sup>1,*5</sup>	N	120	—	240	Times

- Notes:
1. Make each time setting in accordance with the program/program-verify flowchart or erase/erase-verify flowchart.
  2. Programming time per 32 bytes (Shows the total period for which the P-bit in the flash memory control register (FLMCR) is set. It does not include the programming verification time.)
  3. Block erase time (Shows the total period for which the E-bit in FLMCR is set. It does not include the erase verification time.)
  4. To specify the maximum programming time ( $t_p(\text{max})$ ) in the 32-byte programming flowchart, set the max. value (403) for the maximum programming count (N).  
 The wait time after P bit setting (z) should be changed as follows according to the programming counter value.  
 Programming counter value of 1 to 4 :  $z = 150 \mu\text{s}$   
 Programming counter value of 5 to 403 :  $z = 500 \mu\text{s}$
  5. For the maximum erase time ( $t_E(\text{max})$ ), the following relationship applies between the wait time after E bit setting (z) and the maximum erase count (N):  
 $t_E(\text{max}) = \text{Wait time after E bit setting (z)} \times \text{maximum erase count (N)}$   
 To set the maximum erase time, the values of z and N should be set so as to satisfy the above formula.  
 Examples: When  $z = 5$  [ms],  $N = 240$  times  
 When  $z = 10$  [ms],  $N = 120$  times

## 21.3 Operational Timing

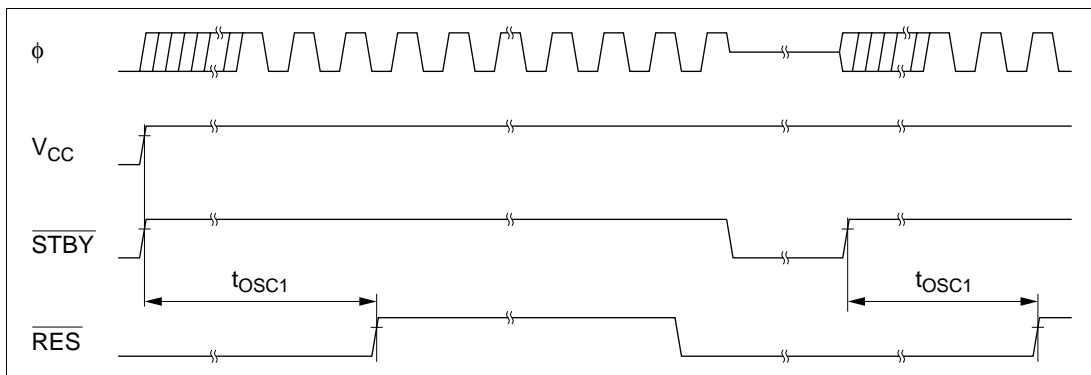
This section shows timing diagrams.

### 21.3.1 Clock Timing

Clock timing is shown as follows:

- Oscillator settling timing

Figure 21.7 shows the oscillator settling timing.



**Figure 21.7 Oscillator Settling Timing**

### 21.3.2 Control Signal Timing

Control signal timing is shown as follows:

- Reset input timing

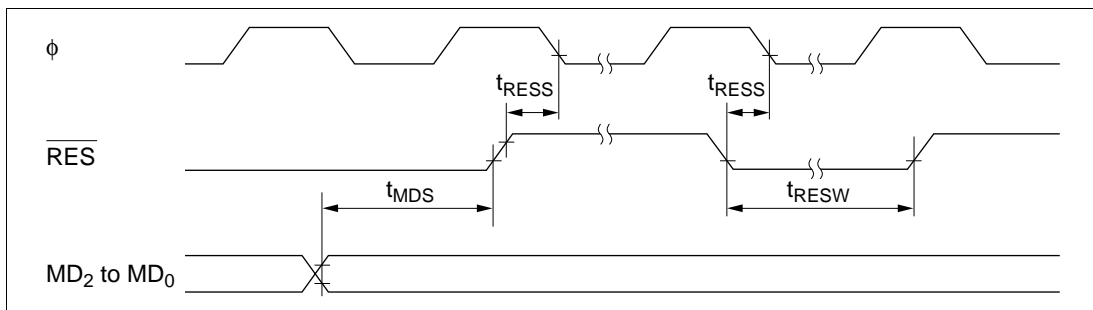
Figure 21.8 shows the reset input timing.

- Reset output timing\*

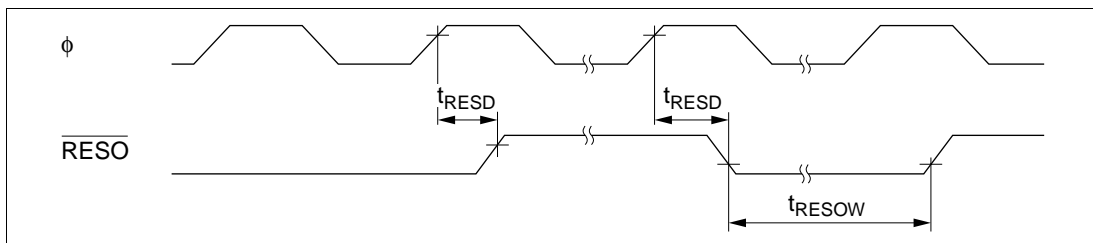
Figure 21.9 shows the reset output timing.

- Interrupt input timing

Figure 21.10 shows the interrupt input timing for NMI and  $\overline{\text{IRQ}}_5$  to  $\overline{\text{IRQ}}_0$ .

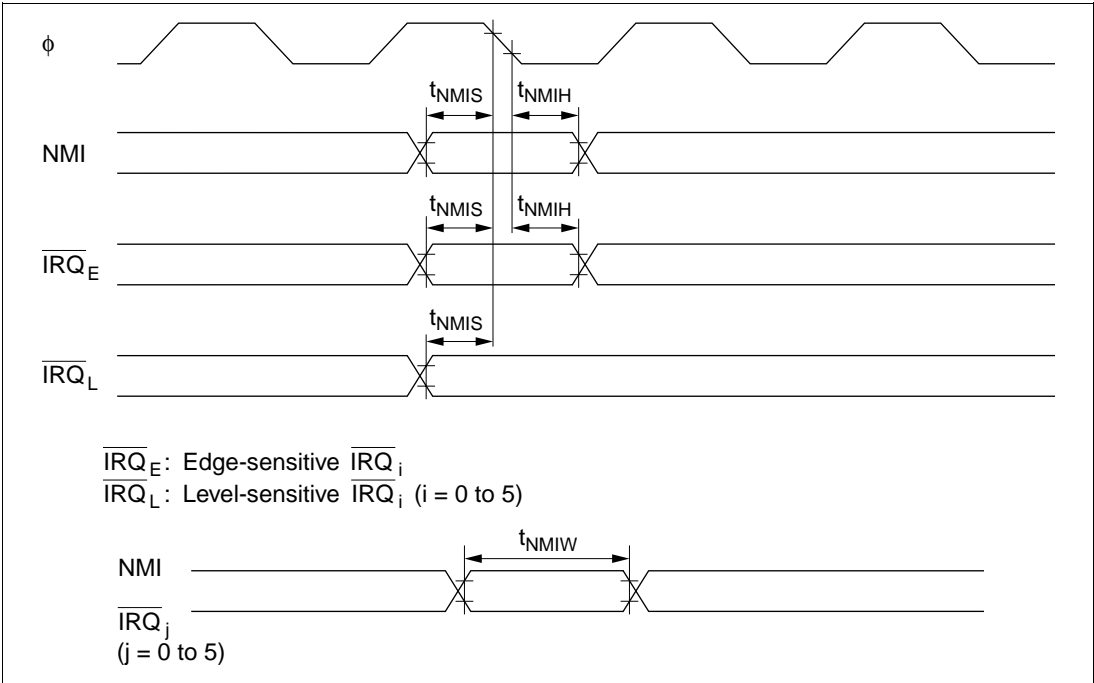


**Figure 21.8 Reset Input Timing**



**Figure 21.9 Reset Output Timing\***

Note: \* This function is used only in the mask ROM version, and is not provided in the flash memory and flash memory R versions.

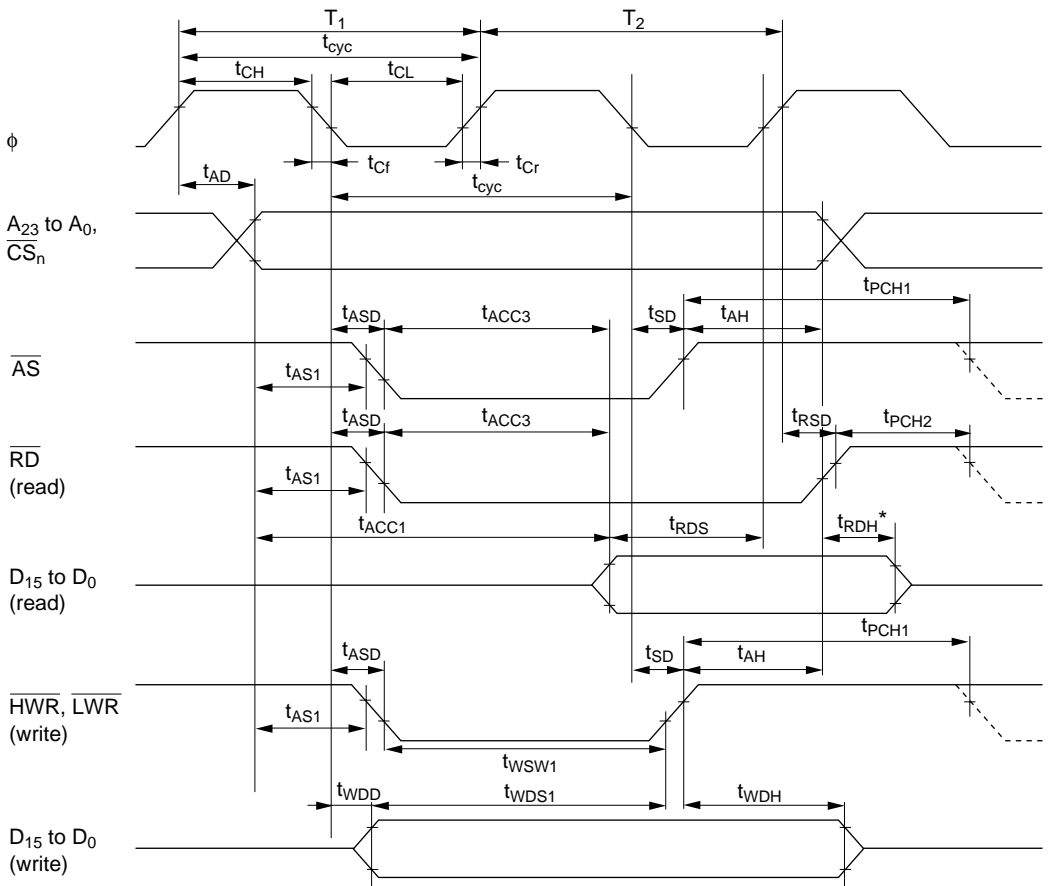


**Figure 21.10 Interrupt Input Timing**

### 21.3.3 Bus Timing

Bus timing is shown as follows:

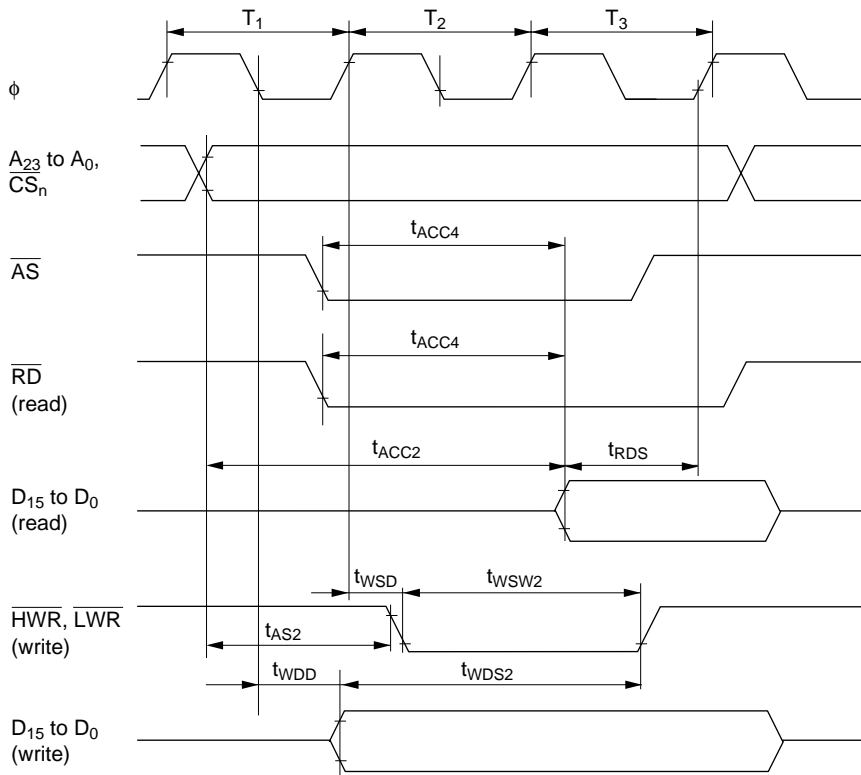
- Basic bus cycle: two-state access  
Figure 21.11 shows the timing of the external two-state access cycle.
- Basic bus cycle: three-state access  
Figure 21.12 shows the timing of the external three-state access cycle.
- Basic bus cycle: three-state access with one wait state  
Figure 21.13 shows the timing of the external three-state access cycle with one wait state inserted.
- Burst ROM access timing: burst cycle two-state  
Figure 21.14 shows the timing of the burst cycle two-state access.
- Burst ROM access timing: burst cycle three-state  
Figure 21.15 shows the timing of the burst cycle three-state access.
- Bus-release mode timing  
Figure 21.16 shows the bus-release mode timing.



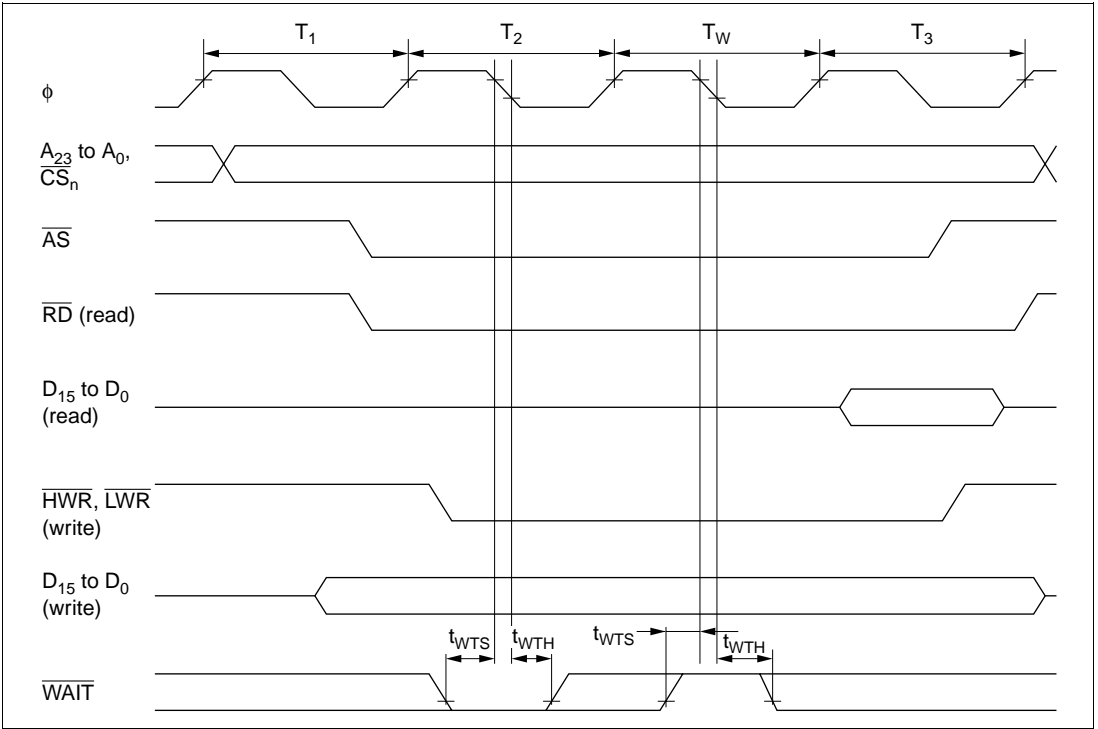
Note: \* Specification from the earliest negation timing of A<sub>23</sub> to A<sub>0</sub>, CS<sub>n</sub>, and RD.

Figure 21.11 Basic Bus Cycle: Two-State Access

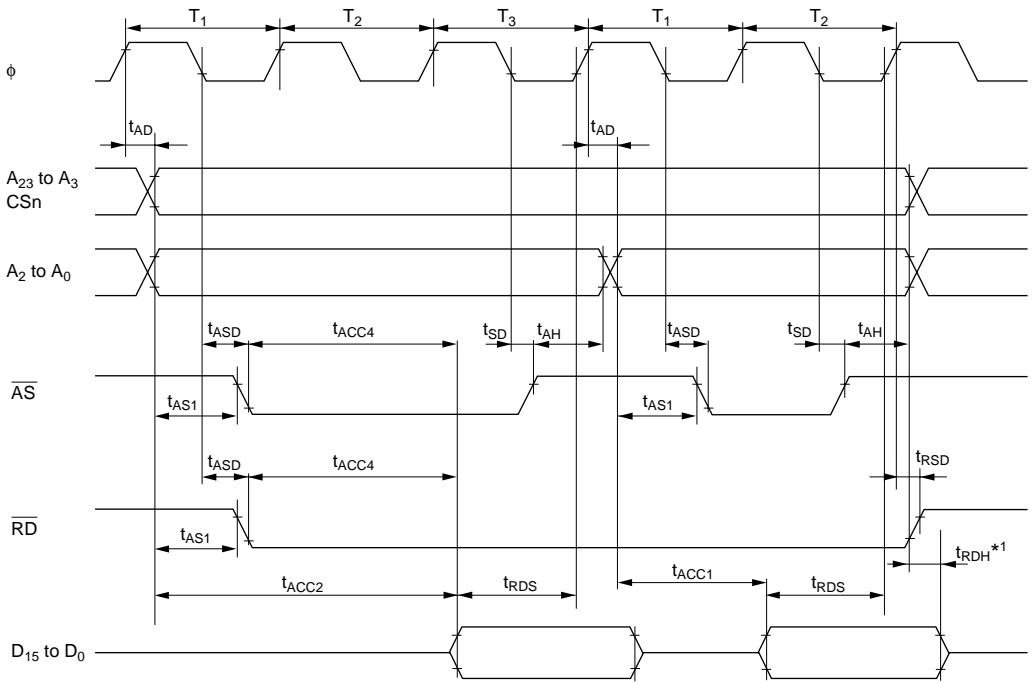




**Figure 21.12 Basic Bus Cycle: Three-State Access**

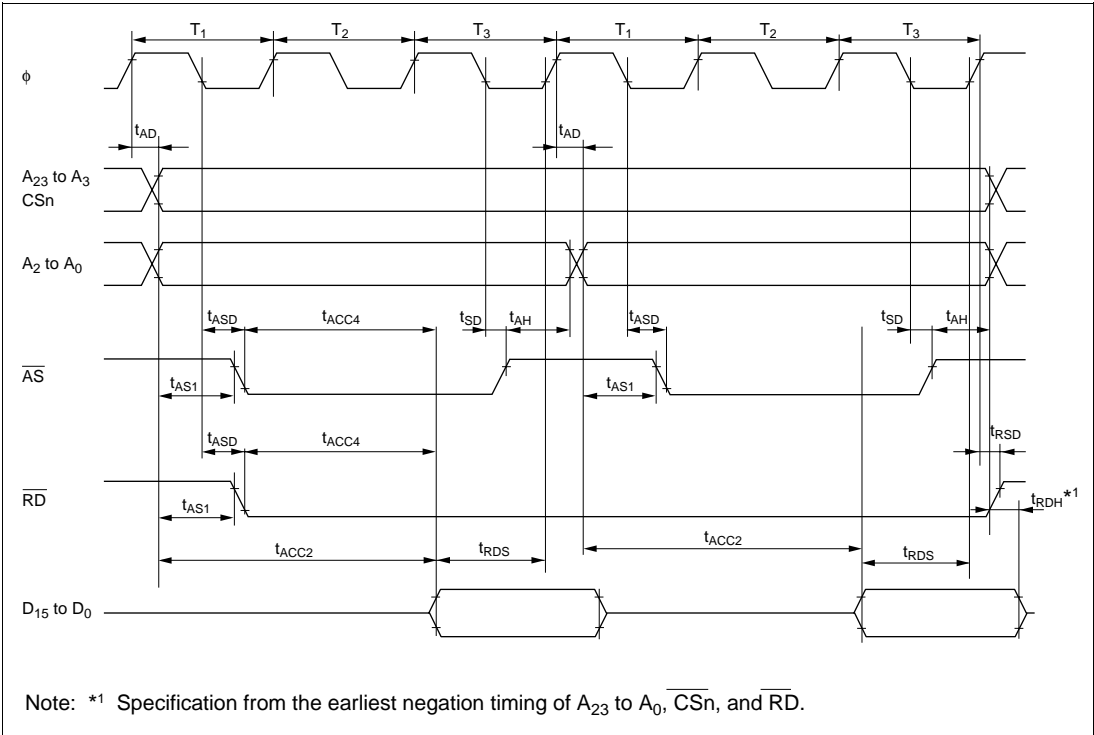


**Figure 21.13 Basic Bus Cycle: Three-State Access with One Wait State**

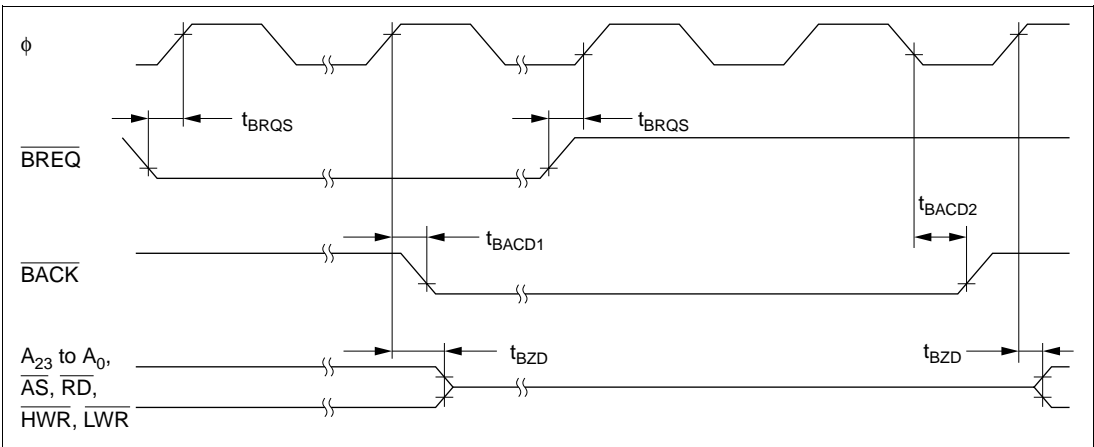


Note: \*1 Specification from the earliest negation timing of A<sub>23</sub> to A<sub>0</sub>, CS<sub>n</sub>, and RD.

**Figure 21.14 Burst ROM Access Timing: Two-State Access**



**Figure 21.15 Burst ROM Access Timing: Three-State Access**

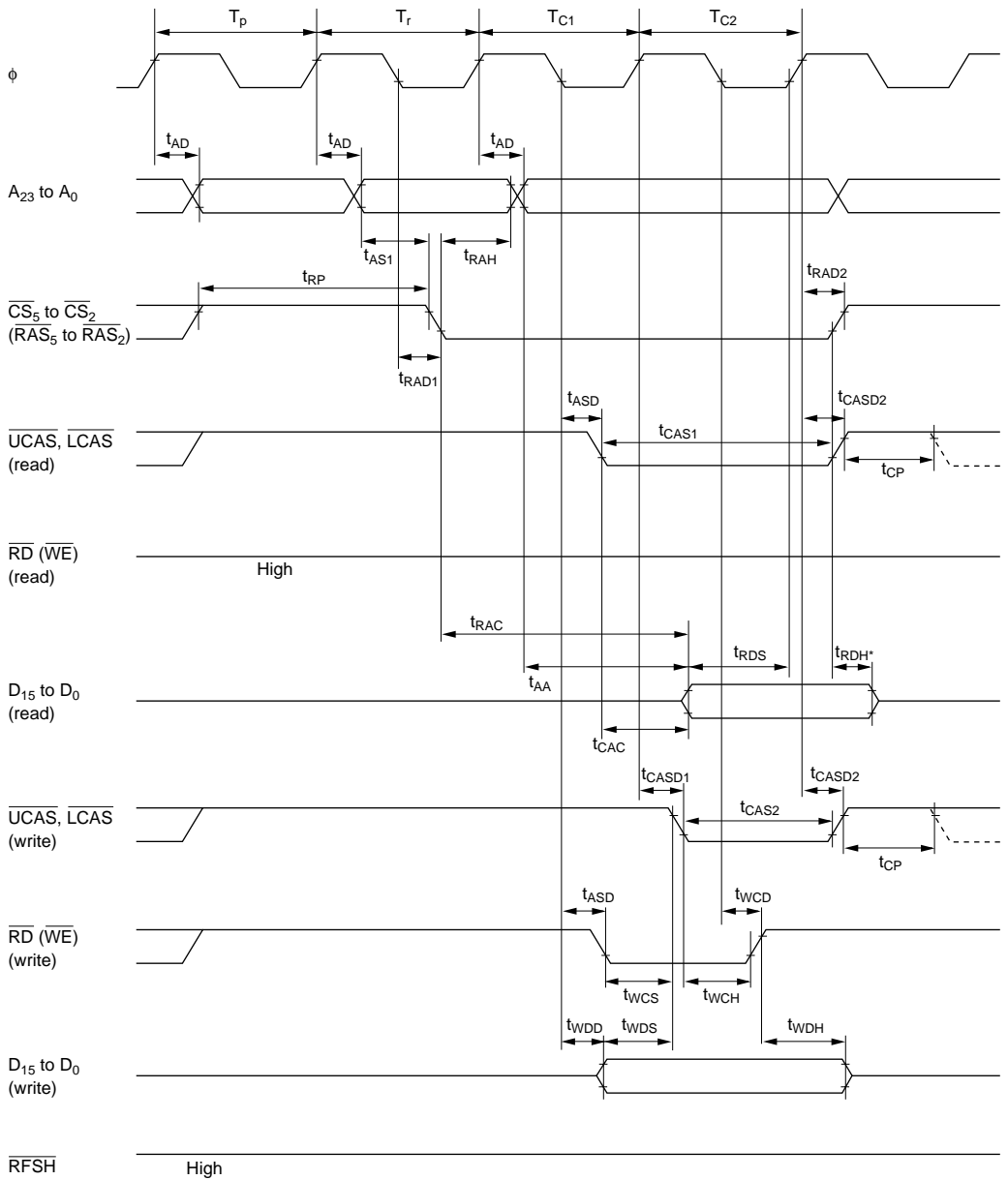


**Figure 21.16 Bus-Release Mode Timing**

### 21.3.4 DRAM Interface Bus Timing

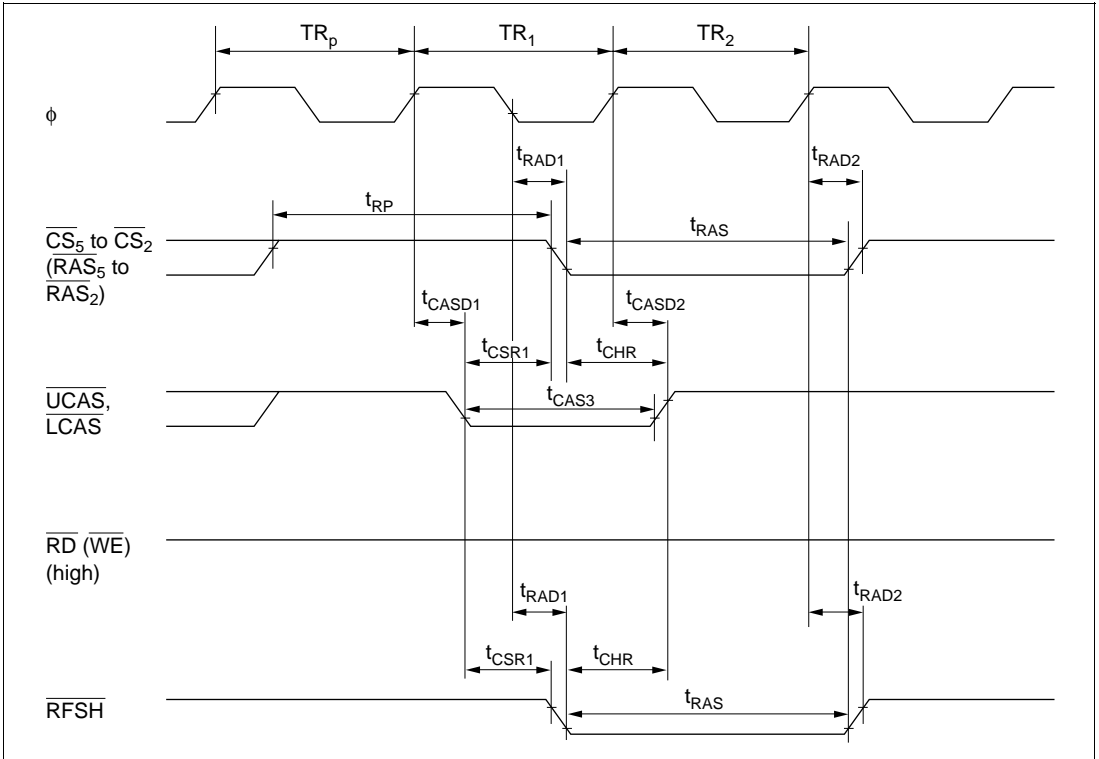
DRAM interface bus timing is shown as follows:

- DRAM bus timing: read and write access  
Figure 21.17 shows the timing of the read and write access.
- DRAM bus timing: CAS before RAS refresh  
Figure 21.18 shows the timing of the CAS before RAS refresh.
- DRAM bus timing: self-refresh  
Figure 21.19 shows the timing of the self-refresh.

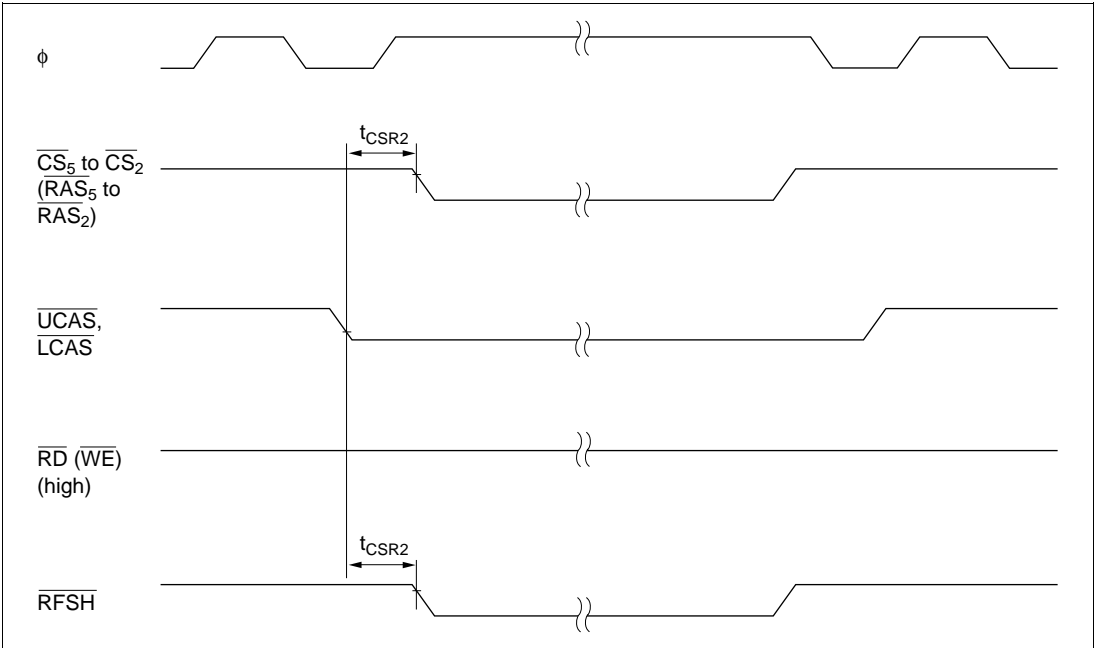


Note: \* Specification from the earliest negation timing of  $\overline{RAS}$  and  $\overline{CAS}$ .

Figure 21.17 DRAM Bus Timing (Read/Write)



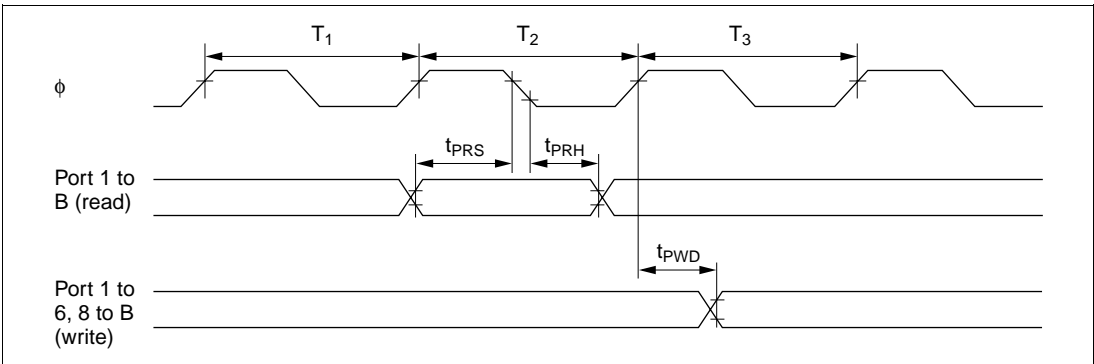
**Figure 21.18 DRAM Bus Timing (CAS Before RAS Refresh)**



**Figure 21.19 DRAM Bus Timing (Self-Refresh)**

### 21.3.5 TPC and I/O Port Timing

Figure 21.20 shows the TPC and I/O port input/output timing.



**Figure 21.20 TPC and I/O Port Input/Output Timing**



### 21.3.6 Timer Input/Output Timing

16-bit timer and 8-bit timer timing is shown as follows:

- Timer input/output timing

Figure 21.21 shows the timer input/output timing.

- Timer external clock input timing

Figure 21.22 shows the timer external clock input timing.

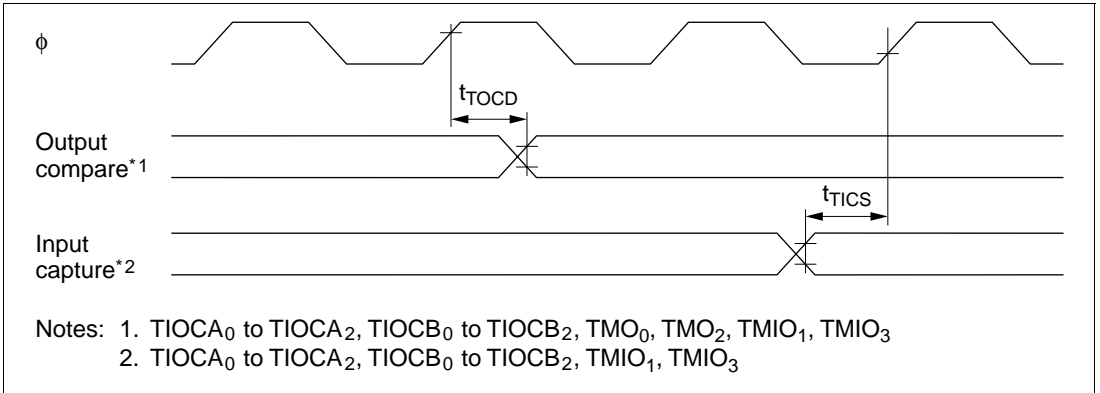


Figure 21.21 Timer Input/Output Timing

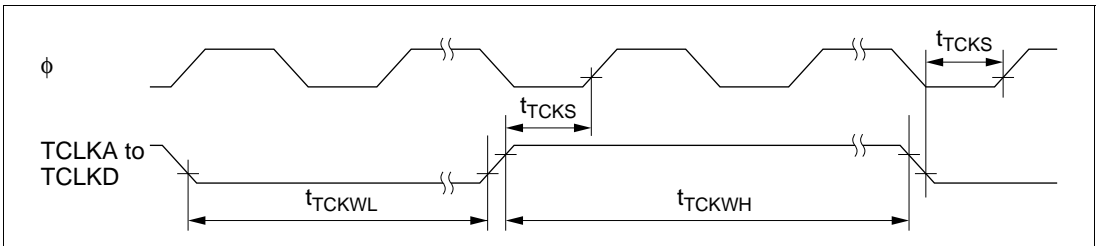


Figure 21.22 Timer External Clock Input Timing

### 21.3.7 SCI Input/Output Timing

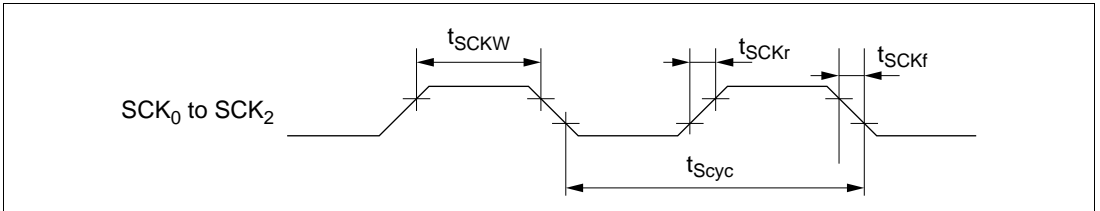
SCI timing is shown as follows:

- SCI input clock timing

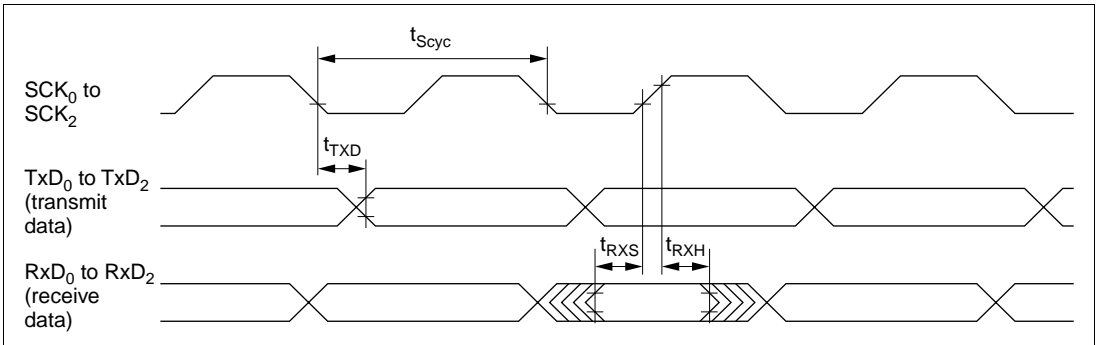
Figure 21.23 shows the SCI input clock timing.

- SCI input/output timing (synchronous mode)

Figure 21.24 shows the SCI input/output timing in synchronous mode.



**Figure 21.23** SCI Input Clock Timing



**Figure 21.24** SCI Input/Output Timing in Synchronous Mode

### 21.3.8 DMAC Timing

DMAC timing is shown as follows.

- DMAC  $\overline{\text{TEND}}$  output timing for 2 state access

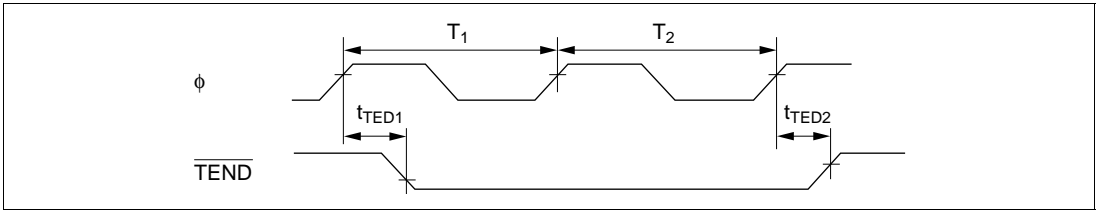
Figure 21.25 shows the DMAC  $\overline{\text{TEND}}$  output timing for 2 state access.

- DMAC  $\overline{\text{TEND}}$  output timing for 3 state access

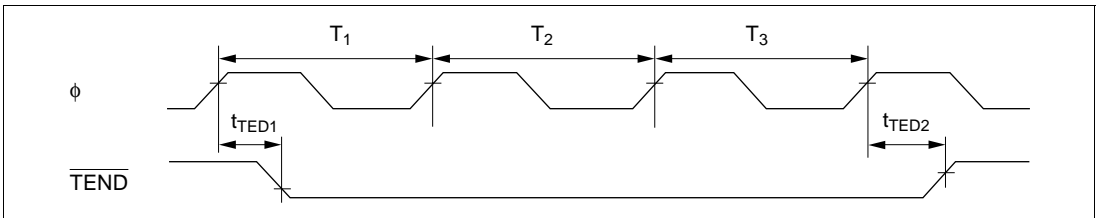
Figure 21.26 shows the DMAC  $\overline{\text{TEND}}$  output timing for 3 state access.

- DMAC  $\overline{\text{DREQ}}$  input timing

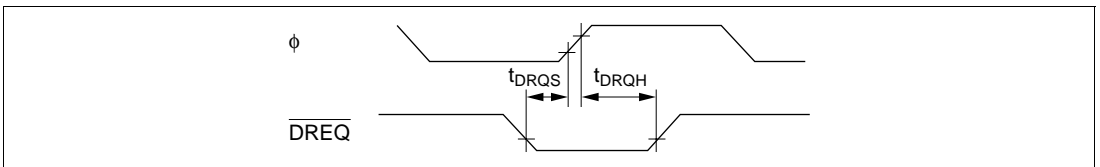
Figure 21.27 shows DMAC  $\overline{\text{DREQ}}$  input timing.



**Figure 21.25 DMAC  $\overline{\text{TEND}}$  Output Timing for 2 State Access**



**Figure 21.26 DMAC  $\overline{\text{TEND}}$  Output Timing for 3 State Access**



**Figure 21.27 DMAC  $\overline{\text{DREQ}}$  Input Timing**



# Appendix A Instruction Set

## A.1 Instruction List

### Operand Notation

Symbol	Description
Rd	General destination register
Rs	General source register
Rn	General register
ERd	General destination register (address register or 32-bit register)
ERs	General source register (address register or 32-bit register)
ERn	General register (32-bit register)
(EAd)	Destination operand
(EAs)	Source operand
PC	Program counter
SP	Stack pointer
CCR	Condition code register
N	N (negative) flag in CCR
Z	Z (zero) flag in CCR
V	V (overflow) flag in CCR
C	C (carry) flag in CCR
disp	Displacement
→	Transfer from the operand on the left to the operand on the right, or transition from the state on the left to the state on the right
+	Addition of the operands on both sides
−	Subtraction of the operand on the right from the operand on the left
×	Multiplication of the operands on both sides
÷	Division of the operand on the left by the operand on the right
^	Logical AND of the operands on both sides
∨	Logical OR of the operands on both sides
⊕	Exclusive logical OR of the operands on both sides
¬	NOT (logical complement)
( ), < >	Contents of operand

Note: General registers include 8-bit registers (R0H to R7H and R0L to R7L) and 16-bit registers (R0 to R7 and E0 to E7).

## Condition Code Notation

Symbol	Description
	Changed according to execution result
*	Undetermined (no guaranteed value)
0	Cleared to 0
1	Set to 1
—	Not affected by execution of the instruction
Δ	Varies depending on conditions, described in notes

**Table A.1 Instruction Set**

## 1. Data transfer instructions

Mnemonic	Operand Size	Addressing Mode and Instruction Length (bytes)								Operation	Condition Code						No. of States <sup>*1</sup>	
		#xx	Rn	@ERn	@(d, ERn)	@-ERn/@ERn+	@aa	@(d, PC)	@@aa		I	H	N	Z	V	C	Normal	Advanced
MOV.B #xx:8, Rd	B	2								#xx:8 → Rd8	—	—	↕	↕	0	—	2	
MOV.B Rs, Rd	B		2							Rs8 → Rd8	—	—	↕	↕	0	—	2	
MOV.B @ERs, Rd	B			2						@ERs → Rd8	—	—	↕	↕	0	—	4	
MOV.B @(d:16, ERs), Rd	B				4					@(d:16, ERs) → Rd8	—	—	↕	↕	0	—	6	
MOV.B @(d:24, ERs), Rd	B					8				@(d:24, ERs) → Rd8	—	—	↕	↕	0	—	10	
MOV.B @ERs+, Rd	B						2			@ERs → Rd8 ERs32+1 → ERs32	—	—	↕	↕	0	—	6	
MOV.B @aa:8, Rd	B							2		@aa:8 → Rd8	—	—	↕	↕	0	—	4	
MOV.B @aa:16, Rd	B								4	@aa:16 → Rd8	—	—	↕	↕	0	—	6	
MOV.B @aa:24, Rd	B								6	@aa:24 → Rd8	—	—	↕	↕	0	—	8	
MOV.B Rs, @ERd	B			2						Rs8 → @ERd	—	—	↕	↕	0	—	4	
MOV.B Rs, @(d:16, ERd)	B				4					Rs8 → @(d:16, ERd)	—	—	↕	↕	0	—	6	
MOV.B Rs, @(d:24, ERd)	B					8				Rs8 → @(d:24, ERd)	—	—	↕	↕	0	—	10	
MOV.B Rs, @-ERd	B						2			ERd32-1 → ERd32 Rs8 → @ERd	—	—	↕	↕	0	—	6	
MOV.B Rs, @aa:8	B							2		Rs8 → @aa:8	—	—	↕	↕	0	—	4	
MOV.B Rs, @aa:16	B								4	Rs8 → @aa:16	—	—	↕	↕	0	—	6	
MOV.B Rs, @aa:24	B								6	Rs8 → @aa:24	—	—	↕	↕	0	—	8	
MOV.W #xx:16, Rd	W	4								#xx:16 → Rd16	—	—	↕	↕	0	—	4	
MOV.W Rs, Rd	W		2							Rs16 → Rd16	—	—	↕	↕	0	—	2	
MOV.W @ERs, Rd	W			2						@ERs → Rd16	—	—	↕	↕	0	—	4	
MOV.W @(d:16, ERs), Rd	W				4					@(d:16, ERs) → Rd16	—	—	↕	↕	0	—	6	
MOV.W @(d:24, ERs), Rd	W					8				@(d:24, ERs) → Rd16	—	—	↕	↕	0	—	10	
MOV.W @ERs+, Rd	W						2			@ERs → Rd16 ERs32+2 → @ERd32	—	—	↕	↕	0	—	6	
MOV.W @aa:16, Rd	W							4		@aa:16 → Rd16	—	—	↕	↕	0	—	6	

**Table A.1 Instruction Set (cont)**

Mnemonic	Operand Size	Addressing Mode and Instruction Length (bytes)								Operation	Condition Code						No. of States*1	
		#xx	Rn	@ERn	@(d, ERn)	@-ERn/@ERn+	@aa	@(d, PC)	@@aa		I	H	N	Z	V	C	Normal	Advanced
MOV.W @aa:24, Rd	W					6			@aa:24 → Rd16	—	—	↑	↓	0	—	8		
MOV.W Rs, @ERd	W			2					Rs16 → @ERd	—	—	↑	↓	0	—	4		
MOV.W Rs, @(d:16, ERd)	W				4				Rs16 → @(d:16, ERd)	—	—	↑	↓	0	—	6		
MOV.W Rs, @(d:24, ERd)	W				8				Rs16 → @(d:24, ERd)	—	—	↑	↓	0	—	10		
MOV.W Rs, @-ERd	W					2			ERd32-2 → ERd32 Rs16 → @ERd	—	—	↑	↓	0	—	6		
MOV.W Rs, @aa:16	W					4			Rs16 → @aa:16	—	—	↑	↓	0	—	6		
MOV.W Rs, @aa:24	W					6			Rs16 → @aa:24	—	—	↑	↓	0	—	8		
MOV.L #xx:32, Rd	L	6							#xx:32 → Rd32	—	—	↑	↓	0	—	6		
MOV.L ERs, ERd	L		2						ERs32 → ERd32	—	—	↑	↓	0	—	2		
MOV.L @ERs, ERd	L			4					@ERs → ERd32	—	—	↑	↓	0	—	8		
MOV.L @(d:16, ERs), ERd	L				6				@(d:16, ERs) → ERd32	—	—	↑	↓	0	—	10		
MOV.L @(d:24, ERs), ERd	L				10				@(d:24, ERs) → ERd32	—	—	↑	↓	0	—	14		
MOV.L @ERs+, ERd	L				4				@ERs → ERd32 ERs32+4 → ERs32	—	—	↑	↓	0	—	10		
MOV.L @aa:16, ERd	L					6			@aa:16 → ERd32	—	—	↑	↓	0	—	10		
MOV.L @aa:24, ERd	L					8			@aa:24 → ERd32	—	—	↑	↓	0	—	12		
MOV.L ERs, @ERd	L			4					ERs32 → @ERd	—	—	↑	↓	0	—	8		
MOV.L ERs, @(d:16, ERd)	L				6				ERs32 → @(d:16, ERd)	—	—	↑	↓	0	—	10		
MOV.L ERs, @(d:24, ERd)	L				10				ERs32 → @(d:24, ERd)	—	—	↑	↓	0	—	14		
MOV.L ERs, @-ERd	L				4				ERd32-4 → ERd32 ERs32 → @ERd	—	—	↑	↓	0	—	10		
MOV.L ERs, @aa:16	L					6			ERs32 → @aa:16	—	—	↑	↓	0	—	10		
MOV.L ERs, @aa:24	L					8			ERs32 → @aa:24	—	—	↑	↓	0	—	12		
POP.W Rn	W							2	@SP → Rn16 SP+2 → SP	—	—	↑	↓	0	—	6		
POP.L ERn	L							4	@SP → ERn32 SP+4 → SP	—	—	↑	↓	0	—	10		





**Table A.1 Instruction Set (cont)**

Mnemonic	Operand Size	Addressing Mode and Instruction Length (bytes)								Operation	Condition Code						No. of States*1	
		#xx	Rn	@ERn	@(d, ERn)	@-ERn/@ERn+	@aa	@(d, PC)	@@aa		I	H	N	Z	V	C	Normal	Advanced
INC.L #1, ERd	L	2								ERd32+1 → ERd32	—	—	↓	↓	↓	—	2	
INC.L #2, ERd	L	2								ERd32+2 → ERd32	—	—	↓	↓	↓	—	2	
DAA Rd	B	2								Rd8 decimal adjust → Rd8	—	*	↓	↓	*	—	2	
SUB.B Rs, Rd	B	2								Rd8-Rs8 → Rd8	—	↓	↓	↓	↓	↓	2	
SUB.W #xx:16, Rd	W	4								Rd16-#xx:16 → Rd16	—	(1)	↓	↓	↓	↓	4	
SUB.W Rs, Rd	W	2								Rd16-Rs16 → Rd16	—	(1)	↓	↓	↓	↓	2	
SUB.L #xx:32, ERd	L	6								ERd32-#xx:32 → ERd32	—	(2)	↓	↓	↓	↓	6	
SUB.L ERs, ERd	L	2								ERd32-ERs32 → ERd32	—	(2)	↓	↓	↓	↓	2	
SUBX.B #xx:8, Rd	B	2								Rd8-#xx:8-C → Rd8	—	↓	↓	(3)	↓	↓	2	
SUBX.B Rs, Rd	B	2								Rd8-Rs8-C → Rd8	—	↓	↓	(3)	↓	↓	2	
SUBS.L #1, ERd	L	2								ERd32-1 → ERd32	—	—	—	—	—	—	2	
SUBS.L #2, ERd	L	2								ERd32-2 → ERd32	—	—	—	—	—	—	2	
SUBS.L #4, ERd	L	2								ERd32-4 → ERd32	—	—	—	—	—	—	2	
DEC.B Rd	B	2								Rd8-1 → Rd8	—	—	↓	↓	↓	—	2	
DEC.W #1, Rd	W	2								Rd16-1 → Rd16	—	—	↓	↓	↓	—	2	
DEC.W #2, Rd	W	2								Rd16-2 → Rd16	—	—	↓	↓	↓	—	2	
DEC.L #1, ERd	L	2								ERd32-1 → ERd32	—	—	↓	↓	↓	—	2	
DEC.L #2, ERd	L	2								ERd32-2 → ERd32	—	—	↓	↓	↓	—	2	
DAS.Rd	B	2								Rd8 decimal adjust → Rd8	—	*	↓	↓	*	—	2	
MULXU. B Rs, Rd	B	2								Rd8 × Rs8 → Rd16 (unsigned multiplication)	—	—	—	—	—	—	14	
MULXU. W Rs, ERd	W	2								Rd16 × Rs16 → ERd32 (unsigned multiplication)	—	—	—	—	—	—	22	
MULXS. B Rs, Rd	B	4								Rd8 × Rs8 → Rd16 (signed multiplication)	—	—	↓	↓	—	—	16	
MULXS. W Rs, ERd	W	4								Rd16 × Rs16 → ERd32 (signed multiplication)	—	—	↓	↓	—	—	24	
DIVXU. B Rs, Rd	B	2								Rd16 ÷ Rs8 → Rd16 (RdH: remainder, RdL: quotient) (unsigned division)	—	—	(6)	(7)	—	—	14	

**Table A.1 Instruction Set (cont)**

Mnemonic	Operand Size	Addressing Mode and Instruction Length (bytes)							Operation	Condition Code						No. of States*1			
		#xx	Rn	@ERn	@{d, ERn}	@-ERn/@ERn+	@aa	@{d, PC}		@aa	I	I	H	N	Z	V	C	Normal	Advanced
DIVXU.W Rs, ERd	W	2								ERd32 ÷ Rs16 → ERd32 (Ed: remainder, Rd: quotient) (unsigned division)	—	—	(6)	(7)	—	—	22		
DIVXS.B Rs, Rd	B	4								Rd16 ÷ Rs8 → Rd16 (RdH: remainder, RdL: quotient) (signed division)	—	—	(8)	(7)	—	—	16		
DIVXS.W Rs, ERd	W	4								ERd32 ÷ Rs16 → ERd32 (Ed: remainder, Rd: quotient) (signed division)	—	—	(8)	(7)	—	—	24		
CMP.B #xx:8, Rd	B	2								Rd8-#xx:8							2		
CMP.B Rs, Rd	B	2								Rd8-Rs8							2		
CMP.W #xx:16, Rd	W	4								Rd16-#xx:16	—	↑	↑	↑	↑	↑	4		
CMP.W Rs, Rd	W	2								Rd16-Rs16							2		
CMP.L #xx:32, ERd	L	6								ERd32-#xx:32	—	↑	↑	↑	↑	↑	6		
CMP.L ERs, ERd	L	2								ERd32-ERs32	—	(1)	↑	↑	↑	↑	2		
NEG.B Rd	B	2								0-Rd8 → Rd8	—	(1)	↑	↑	↑	↑	2		
NEG.W Rd	W	2								0-Rd16 → Rd16	—	(1)	↑	↑	↑	↑	2		
NEG.L ERd	L	2								0-ERd32 → ERd32	—	(1)	↑	↑	↑	↑	2		
EXTU.W Rd	W	2								0 → (<bits 15 to 8> of Rd16)	—	(2)	↑	↑	↑	↑	2		
EXTU.L ERd	L	2								0 → (<bits 31 to 16> of ERd32)	—	(2)	↑	↑	↑	↑	2		
EXTS.W Rd	W	2								(<bit 7> of Rd16) → (<bits 15 to 8> of Rd16)	—	↑	↑	↑	↑	↑	2		
EXTS.L ERd	L	2								(<bit 15> of ERd32) → (<bits 31 to 16> of ERd32)	—	↑	↑	↑	↑	↑	2		

## Table A.1 Instruction Set (cont)

### 3. Logic instructions

Mnemonic	Operand Size	Addressing Mode and Instruction Length (bytes)								Operation	Condition Code						No. of States*1	
		#xx	Rn	@ERn	@(d, ERn)	@-ERn/@ERn+	@aa	@(d, PC)	@@aa		I	H	N	Z	V	C	Normal	Advanced
AND.B #xx:8, Rd	B	2								Rd8 $\wedge$ #xx:8 $\rightarrow$ Rd8	—	—	$\updownarrow$	$\updownarrow$	0	—	2	
AND.B Rs, Rd	B	2								Rd8 $\wedge$ Rs8 $\rightarrow$ Rd8	—	—	$\updownarrow$	$\updownarrow$	0	—	2	
AND.W #xx:16, Rd	W	4								Rd16 $\wedge$ #xx:16 $\rightarrow$ Rd16	—	—	$\updownarrow$	$\updownarrow$	0	—	4	
AND.W Rs, Rd	W	2								Rd16 $\wedge$ Rs16 $\rightarrow$ Rd16	—	—	$\updownarrow$	$\updownarrow$	0	—	2	
AND.L #xx:32, ERd	L	6								ERd32 $\wedge$ #xx:32 $\rightarrow$ ERd32	—	—	$\updownarrow$	$\updownarrow$	0	—	6	
AND.L ERs, ERd	L	4								ERd32 $\wedge$ ERs32 $\rightarrow$ ERd32	—	—	$\updownarrow$	$\updownarrow$	0	—	4	
OR.B #xx:8, Rd	B	2								Rd8 $\vee$ #xx:8 $\rightarrow$ Rd8	—	—	$\updownarrow$	$\updownarrow$	0	—	2	
OR.B Rs, Rd	B	2								Rd8 $\vee$ Rs8 $\rightarrow$ Rd8	—	—	$\updownarrow$	$\updownarrow$	0	—	2	
OR.W #xx:16, Rd	W	4								Rd16 $\vee$ #xx:16 $\rightarrow$ Rd16	—	—	$\updownarrow$	$\updownarrow$	0	—	4	
OR.W Rs, Rd	W	2								Rd16 $\vee$ Rs16 $\rightarrow$ Rd16	—	—	$\updownarrow$	$\updownarrow$	0	—	2	
OR.L #xx:32, ERd	L	6								ERd32 $\vee$ #xx:32 $\rightarrow$ ERd32	—	—	$\updownarrow$	$\updownarrow$	0	—	6	
OR.L ERs, ERd	L	4								ERd32 $\vee$ ERs32 $\rightarrow$ ERd32	—	—	$\updownarrow$	$\updownarrow$	0	—	4	
XOR.B #xx:8, Rd	B	2								Rd8 $\oplus$ #xx:8 $\rightarrow$ Rd8	—	—	$\updownarrow$	$\updownarrow$	0	—	2	
XOR.B Rs, Rd	B	2								Rd8 $\oplus$ Rs8 $\rightarrow$ Rd8	—	—	$\updownarrow$	$\updownarrow$	0	—	2	
XOR.W #xx:16, Rd	W	4								Rd16 $\oplus$ #xx:16 $\rightarrow$ Rd16	—	—	$\updownarrow$	$\updownarrow$	0	—	4	
XOR.W Rs, Rd	W	2								Rd16 $\oplus$ Rs16 $\rightarrow$ Rd16	—	—	$\updownarrow$	$\updownarrow$	0	—	2	
XOR.L #xx:32, ERd	L	6								ERd32 $\oplus$ #xx:32 $\rightarrow$ ERd32	—	—	$\updownarrow$	$\updownarrow$	0	—	6	
XOR.L ERs, ERd	L	4								ERd32 $\oplus$ ERs32 $\rightarrow$ ERd32	—	—	$\updownarrow$	$\updownarrow$	0	—	4	
NOT.B Rd	B	2								$\neg$ Rd8 $\rightarrow$ Rd8	—	—	$\updownarrow$	$\updownarrow$	0	—	2	
NOT.W Rd	W	2								$\neg$ Rd16 $\rightarrow$ Rd16	—	—	$\updownarrow$	$\updownarrow$	0	—	2	
NOT.L ERd	L	2								$\neg$ Rd32 $\rightarrow$ Rd32	—	—	$\updownarrow$	$\updownarrow$	0	—	2	

**Table A.1 Instruction Set (cont)**

4. Shift instructions

Mnemonic	Addressing Mode and Instruction Length (bytes)								Operation	Condition Code						No. of States <sup>*1</sup>		
	Operand Size	#xx	Rn	@ERn	@ (d, ERn)	@-ERn/@ERn+	@aa	@ (d, PC)		@@aa	I	H	N	Z	V	C	Normal	Advanced
SHAL.B Rd	B	2															2	
SHAL.W Rd	W	2															2	
SHAL.L ERd	L	2																2
SHAR.B Rd	B	2															2	
SHAR.W Rd	W	2															2	
SHAR.L ERd	L	2															2	
SHLL.B Rd	B	2															2	
SHLL.W Rd	W	2															2	
SHLL.L ERd	L	2															2	
SHLR.B Rd	B	2															2	
SHLR.W Rd	W	2															2	
SHLR.L ERd	L	2															2	
ROTXL.B Rd	B	2															2	
ROTXL.W Rd	W	2															2	
ROTXL.L ERd	L	2															2	
ROTXR.B Rd	B	2															2	
ROTXR.W Rd	W	2															2	
ROTXR.L ERd	L	2															2	
ROTL.B Rd	B	2															2	
ROTL.W Rd	W	2															2	
ROTL.L ERd	L	2															2	
ROTR.B Rd	B	2															2	
ROTR.W Rd	W	2															2	
ROTR.L ERd	L	2															2	

**Table A.1 Instruction Set (cont)**

## 5. Bit manipulation instructions

Mnemonic	Operand Size	Addressing Mode and Instruction Length (bytes)								Operation	Condition Code						No. of States*1		
		#xx	Rn	@ERn	@ (d, ERn)	@-ERn/@ERn+	@aa	@ (d, PC)	@ @aa		I	I	H	N	Z	V	C	Normal	Advanced
BSET #xx:3, Rd	B	2																2	
BSET #xx:3, @ERd	B		4															8	
BSET #xx:3, @aa:8	B					4												8	
BSET Rn, Rd	B	2																2	
BSET Rn, @ERd	B		4															8	
BSET Rn, @aa:8	B					4												8	
BCLR #xx:3, Rd	B	2																2	
BCLR #xx:3, @ERd	B		4															8	
BCLR #xx:3, @aa:8	B					4												8	
BCLR Rn, Rd	B	2																2	
BCLR Rn, @ERd	B		4															8	
BCLR Rn, @aa:8	B					4												8	
BNOT #xx:3, Rd	B	2																2	
BNOT #xx:3, @ERd	B		4															8	
BNOT #xx:3, @aa:8	B					4												8	
BNOT Rn, Rd	B	2																2	
BNOT Rn, @ERd	B		4															8	
BNOT Rn, @aa:8	B					4												8	
BTST #xx:3, Rd	B	2																2	
BTST #xx:3, @ERd	B		4															6	
BTST #xx:3, @aa:8	B					4												6	
BTST Rn, Rd	B	2																2	
BTST Rn, @ERd	B		4															6	
BTST Rn, @aa:8	B					4												6	
BLD #xx:3, Rd	B	2																2	

**Table A.1 Instruction Set (cont)**

Mnemonic	Operand Size	Addressing Mode and Instruction Length (bytes)							Operation	Condition Code						No. of States*1			
		#xx	Rn	@ERn	@{d, ERn}	@-ERn/@ERn+	@aa	@{d, PC}		@aa	I	I	H	N	Z	V	C	Normal	Advanced
BLD #xx:3, @ERd	B		4						(#xx:3 of @ERd) → C	—	—	—	—	—	↑		6		
BLD #xx:3, @aa:8	B					4			(#xx:3 of @aa:8) → C	—	—	—	—	—	↑		6		
BILD #xx:3, Rd	B	2							¬ (#xx:3 of Rd8) → C	—	—	—	—	—	↑		2		
BILD #xx:3, @ERd	B		4						¬ (#xx:3 of @ERd) → C	—	—	—	—	—	↑		6		
BILD #xx:3, @aa:8	B					4			¬ (#xx:3 of @aa:8) → C	—	—	—	—	—	↑		6		
BST #xx:3, Rd	B	2							C → (#xx:3 of Rd8)	—	—	—	—	—	—		2		
BST #xx:3, @ERd	B		4						C → (#xx:3 of @ERd24)	—	—	—	—	—	—		8		
BST #xx:3, @aa:8	B					4			C → (#xx:3 of @aa:8)	—	—	—	—	—	—		8		
BIST #xx:3, Rd	B	2							¬ C → (#xx:3 of Rd8)	—	—	—	—	—	—		2		
BIST #xx:3, @ERd	B		4						¬ C → (#xx:3 of @ERd24)	—	—	—	—	—	—		8		
BIST #xx:3, @aa:8	B					4			¬ C → (#xx:3 of @aa:8)	—	—	—	—	—	—		8		
BAND #xx:3, Rd	B	2							C ∧ (#xx:3 of Rd8) → C	—	—	—	—	—	↑		2		
BAND #xx:3, @ERd	B		4						C ∧ (#xx:3 of @ERd24) → C	—	—	—	—	—	↑		6		
BAND #xx:3, @aa:8	B					4			C ∧ (#xx:3 of @aa:8) → C	—	—	—	—	—	↑		6		
BIAND #xx:3, Rd	B	2							C ∧ ¬ (#xx:3 of Rd8) → C	—	—	—	—	—	↑		2		
BIAND #xx:3, @ERd	B		4						C ∧ ¬ (#xx:3 of @ERd24) → C	—	—	—	—	—	↑		6		
BIAND #xx:3, @aa:8	B					4			C ∧ ¬ (#xx:3 of @aa:8) → C	—	—	—	—	—	↑		6		
BOR #xx:3, Rd	B	2							C ∨ (#xx:3 of Rd8) → C	—	—	—	—	—	↑		2		
BOR #xx:3, @ERd	B		4						C ∨ (#xx:3 of @ERd24) → C	—	—	—	—	—	↑		6		
BOR #xx:3, @aa:8	B					4			C ∨ (#xx:3 of @aa:8) → C	—	—	—	—	—	↑		6		
BIOR #xx:3, Rd	B	2							C ∨ ¬ (#xx:3 of Rd8) → C	—	—	—	—	—	↑		2		
BIOR #xx:3, @ERd	B		4						C ∨ ¬ (#xx:3 of @ERd24) → C	—	—	—	—	—	↑		6		
BIOR #xx:3, @aa:8	B					4			C ∨ ¬ (#xx:3 of @aa:8) → C	—	—	—	—	—	↑		6		
BXOR #xx:3, Rd	B	2							C ⊕ (#xx:3 of Rd8) → C	—	—	—	—	—	↑		2		
BXOR #xx:3, @ERd	B		4						C ⊕ (#xx:3 of @ERd24) → C	—	—	—	—	—	↑		6		
BXOR #xx:3, @aa:8	B					4			C ⊕ (#xx:3 of @aa:8) → C	—	—	—	—	—	↑		6		
BIXOR #xx:3, Rd	B	2							C ⊕ ¬ (#xx:3 of Rd8) → C	—	—	—	—	—	↑		2		
BIXOR #xx:3, @ERd	B		4						C ⊕ ¬ (#xx:3 of @ERd24) → C	—	—	—	—	—	↑		6		
BIXOR #xx:3, @aa:8	B					4			C ⊕ ¬ (#xx:3 of @aa:8) → C	—	—	—	—	—	↑		6		

**Table A.1 Instruction Set (cont)**

## 6. Branching instructions

Mnemonic	Operand Size	Addressing Mode and Instruction Length (bytes)								Operation	Branch Condition	Condition Code						No. of States*1	
		#xx	Rn	@ERn	@(d, ERn)	@-ERn/@ERn+	@aa	@(d, PC)	@@aa			I	H	N	Z	V	C	Normal	Advanced
BRA d:8 (BT d:8)	—							2		If condition is true then PC ← PC+d else next;	Always	—	—	—	—	—	—	4	
BRA d:16 (BT d:16)	—							4			Never	—	—	—	—	—	—	—	6
BRN d:8 (BF d:8)	—							2			Never	—	—	—	—	—	—	4	
BRN d:16 (BF d:16)	—							4			Never	—	—	—	—	—	—	—	6
BHI d:8	—							2			C ∨ Z = 0	—	—	—	—	—	—	4	
BHI d:16	—							4			C ∨ Z = 0	—	—	—	—	—	—	—	6
BLS d:8	—							2			C ∨ Z = 1	—	—	—	—	—	—	4	
BLS d:16	—							4			C ∨ Z = 1	—	—	—	—	—	—	—	6
BCC d:8 (BHS d:8)	—							2			C = 0	—	—	—	—	—	—	4	
BCC d:16 (BHS d:16)	—							4			C = 0	—	—	—	—	—	—	—	6
BCS d:8 (BLO d:8)	—							2			C = 1	—	—	—	—	—	—	4	
BCS d:16 (BLO d:16)	—							4			C = 1	—	—	—	—	—	—	—	6
BNE d:8	—							2			Z = 0	—	—	—	—	—	—	4	
BNE d:16	—							4			Z = 0	—	—	—	—	—	—	—	6
BEQ d:8	—							2			Z = 1	—	—	—	—	—	—	4	
BEQ d:16	—							4			Z = 1	—	—	—	—	—	—	—	6
BVC d:8	—							2			V = 0	—	—	—	—	—	—	4	
BVC d:16	—							4			V = 0	—	—	—	—	—	—	—	6
BVS d:8	—							2			V = 1	—	—	—	—	—	—	4	
BVS d:16	—							4			V = 1	—	—	—	—	—	—	—	6
BPL d:8	—							2			N = 0	—	—	—	—	—	—	4	
BPL d:16	—							4			N = 0	—	—	—	—	—	—	—	6
BMI d:8	—							2			N = 1	—	—	—	—	—	—	4	
BMI d:16	—							4			N = 1	—	—	—	—	—	—	—	6
BGE d:8	—							2			N ⊕ V = 0	—	—	—	—	—	—	4	
BGE d:16	—							4			N ⊕ V = 0	—	—	—	—	—	—	—	6
BLT d:8	—							2			N ⊕ V = 1	—	—	—	—	—	—	4	
BLT d:16	—							4			N ⊕ V = 1	—	—	—	—	—	—	—	6
BGT d:8	—							2			Z ∨ (N ⊕ V) = 0	—	—	—	—	—	—	4	
BGT d:16	—							4			Z ∨ (N ⊕ V) = 0	—	—	—	—	—	—	—	6



**Table A.1 Instruction Set (cont)**

Mnemonic	Operand Size	Addressing Mode and Instruction Length (bytes)								Operation	Branch Condition	Condition Code						No. of States*1	
		#xx	Rn	@ERn	@(d, ERn)	@-ERn/@ERn+	@aa	@(d, PC)	@@aa			I	H	N	Z	V	C	Normal	Advanced
BLE d:8	—							2		If condition is true then PC ← PC+d else next;	Z ∨ (N⊕V) = 1	—	—	—	—	—	—	4	
BLE d:16	—						4						—	—	—	—	—	—	6
JMP @ERn	—			2						PC ← ERn		—	—	—	—	—	—	4	
JMP @aa:24	—						4			PC ← aa:24		—	—	—	—	—	—	6	
JMP @@aa:8	—							2		PC ← @aa:8		—	—	—	—	—	—	8	10
BSR d:8	—							2		PC → @-SP PC ← PC+d:8		—	—	—	—	—	—	6	8
BSR d:16	—							4		PC → @-SP PC ← PC+d:16		—	—	—	—	—	—	8	10
JSR @ERn	—			2						PC → @-SP PC ← @ERn		—	—	—	—	—	—	6	8
JSR @aa:24	—						4			PC → @-SP PC ← @aa:24		—	—	—	—	—	—	8	10
JSR @@aa:8	—							2		PC → @-SP PC ← @aa:8		—	—	—	—	—	—	8	12
RTS	—							2		PC ← @SP+		—	—	—	—	—	—	8	10

**Table A.1 Instruction Set (cont)**

## 7. System control instructions

Mnemonic	Operand Size	Addressing Mode and Instruction Length (bytes)								Operation	Condition Code						No. of States*1	
		#xx	Rn	@ERn	@(d, ERn)	@-ERn/@ERn+	@aa	@(d, PC)	@@aa		I	H	N	Z	V	C	Normal	Advanced
TRAPA #x:2	—								2	PC → @-SP CCR → @-SP <vector> → PC	1	—	—	—	—	—	14	16
RTE	—									CCR ← @SP+ PC ← @SP+	↑	↑	↑	↑	↑	↑	10	
SLEEP	—									Transition to powerdown state	—	—	—	—	—	—	2	
LDC #xx:8, CCR	B	2								#xx:8 → CCR	↑	↑	↑	↑	↑	↑	2	
LDC Rs, CCR	B		2							Rs8 → CCR	↑	↑	↑	↑	↑	↑	2	
LDC @ERs, CCR	W			4						@ERs → CCR	↑	↑	↑	↑	↑	↑	6	
LDC @(d:16, ERs), CCR	W				6					@(d:16, ERs) → CCR	↑	↑	↑	↑	↑	↑	8	
LDC @(d:24, ERs), CCR	W					10				@(d:24, ERs) → CCR	↑	↑	↑	↑	↑	↑	12	
LDC @ERs+, CCR	W						4			@ERs → CCR ERs32+2 → ERs32	↑	↑	↑	↑	↑	↑	8	
LDC @aa:16, CCR	W							6		@aa:16 → CCR	↑	↑	↑	↑	↑	↑	8	
LDC @aa:24, CCR	W								8	@aa:24 → CCR	↑	↑	↑	↑	↑	↑	10	
STC CCR, Rd	B		2							CCR → Rd8	—	—	—	—	—	—	2	
STC CCR, @ERd	W			4						CCR → @ERd	—	—	—	—	—	—	6	
STC CCR, @(d:16, ERd)	W				6					CCR → @(d:16, ERd)	—	—	—	—	—	—	8	
STC CCR, @(d:24, ERd)	W					10				CCR → @(d:24, ERd)	—	—	—	—	—	—	12	
STC CCR, @-ERd	W						4			ERd32-2 → ERd32 CCR → @ERd	—	—	—	—	—	—	8	
STC CCR, @aa:16	W							6		CCR → @aa:16	—	—	—	—	—	—	8	
STC CCR, @aa:24	W								8	CCR → @aa:24	—	—	—	—	—	—	10	
ANDC #xx:8, CCR	B	2								CCR ∧ #xx:8 → CCR	↑	↑	↑	↑	↑	↑	2	
ORC #xx:8, CCR	B	2								CCR ∨ #xx:8 → CCR	↑	↑	↑	↑	↑	↑	2	
XORC #xx:8, CCR	B	2								CCR ⊕ #xx:8 → CCR	↑	↑	↑	↑	↑	↑	2	
NOP	—								2	PC ← PC+2	—	—	—	—	—	—	2	

**Table A.1 Instruction Set (cont)**

8. Block transfer instructions

Mnemonic	Operand Size	Addressing Mode and Instruction Length (bytes)								Operation	Condition Code						No. of States*1		
		#xx	Rn	@ERn	@(d, ERn)	@-ERn/@ERn+	@aa	@(d, PC)	@@aa		I	H	N	Z	V	C	Normal	Advanced	
EEPMOV. B	—									4	if R4L ≠ 0 repeat @R5 → @R6 R5+1 → R5 R6+1 → R6 R4L-1 → R4L until R4L=0 else next;	—	—	—	—	—	—	8+	4n <sup>+2</sup>
EEPMOV. W	—									4	if R4 ≠ 0 repeat @R5 → @R6 R5+1 → R5 R6+1 → R6 R4-1 → R4 until R4=0 else next;	—	—	—	—	—	—	8+	4n <sup>+2</sup>

Notes: 1. The number of states is the number of states required for execution when the instruction and its operands are located in on-chip memory. For other cases see section A.3.

2. n is the value set in register R4L or R4.

- (1) Set to 1 when a carry or borrow occurs at bit 11; otherwise cleared to 0.
- (2) Set to 1 when a carry or borrow occurs at bit 27; otherwise cleared to 0.
- (3) Retains its previous value when the result is zero; otherwise cleared to 0.
- (4) Set to 1 when the adjustment produces a carry; otherwise retains its previous value.
- (5) The number of states required for execution of an instruction that transfers data in synchronization with the E clock is variable.
- (6) Set to 1 when the divisor is negative; otherwise cleared to 0.
- (7) Set to 1 when the divisor is zero; otherwise cleared to 0.
- (8) Set to 1 when the quotient is negative; otherwise cleared to 0.


## A.2 Operation Code Maps

Table A.2 Operation Code Map (1)

Instruction code: 

1st byte	2nd byte
AH   AL	BH   BL



AL / AH	0	1	2	3	4	5	6	7	8	9	A	B	C	D	E	F																																																																				
0	NOP	Table A.2 (2)	STC	LDC	ORC	XORC	ANDC	LDC	ADD	Table A.2 (2)	Table A.2 (2)	Table A.2 (2)	Table A.2 (2)	MOV	ADDX	Table A.2 (2)																																																																				
1	Table A.2 (2)	Table A.2 (2)	Table A.2 (2)	Table A.2 (2)	OR.B	XOR.B	AND.B	Table A.2 (2)	SUB	Table A.2 (2)	Table A.2 (2)	Table A.2 (2)	Table A.2 (2)	CMP	SUBX	Table A.2 (2)																																																																				
2	MOV.B																																																																																			
3	MOV																																																																																			
4	BRA	BRN	BHI	BLS	BCC	BCS	BNE	BNQ	BVC	BVS	BPL	BMI	BGE	BLT	BGT	BLE																																																																				
5	MULXU	DIVXU	MULXU	DIVXU	RTS	BSR	RTE	TRAPA	Table A.2 (2)	JMP	BSR	JSR																																																																								
6	BSET	BNOT	BCLR	BTST	BIOR	BXOR	BAND	AND	BSL	MOV																																																																										
7	<table border="1" style="width: 100%; border-collapse: collapse; text-align: center;"> <tr> <td>BOR</td> <td>BAND</td> <td>BAND</td> <td>BAND</td> <td>BAND</td> <td>BAND</td> <td>BAND</td> <td>BAND</td> <td>BAND</td> <td>BAND</td> <td>BAND</td> <td>BAND</td> <td>BAND</td> <td>BAND</td> <td>BAND</td> <td>BAND</td> <td>BAND</td> </tr> <tr> <td>BOR</td> <td>BXOR</td> <td>BXOR</td> <td>BXOR</td> <td>BXOR</td> <td>BXOR</td> <td>BXOR</td> <td>BXOR</td> <td>BXOR</td> <td>BXOR</td> <td>BXOR</td> <td>BXOR</td> <td>BXOR</td> <td>BXOR</td> <td>BXOR</td> <td>BXOR</td> <td>BXOR</td> </tr> <tr> <td>BOR</td> <td>BOR</td> <td>BIAND</td> <td>BIAND</td> <td>BIAND</td> <td>BIAND</td> <td>BIAND</td> <td>BIAND</td> <td>BIAND</td> <td>BIAND</td> <td>BIAND</td> <td>BIAND</td> <td>BIAND</td> <td>BIAND</td> <td>BIAND</td> <td>BIAND</td> <td>BIAND</td> </tr> <tr> <td>BOR</td> <td>BOR</td> <td>BOR</td> <td>BOR</td> <td>BOR</td> <td>BOR</td> <td>BOR</td> <td>BOR</td> <td>BOR</td> <td>BOR</td> <td>BOR</td> <td>BOR</td> <td>BOR</td> <td>BOR</td> <td>BOR</td> <td>BOR</td> <td>BOR</td> </tr> </table>																BOR	BAND	BAND	BAND	BAND	BAND	BAND	BAND	BAND	BAND	BAND	BAND	BAND	BAND	BAND	BAND	BAND	BOR	BXOR	BXOR	BXOR	BXOR	BXOR	BXOR	BXOR	BXOR	BXOR	BXOR	BXOR	BXOR	BXOR	BXOR	BXOR	BXOR	BOR	BOR	BIAND	BIAND	BIAND	BIAND	BIAND	BIAND	BIAND	BIAND	BIAND	BIAND	BIAND	BIAND	BIAND	BIAND	BIAND	BOR	BOR	BOR	BOR	BOR	BOR	BOR	BOR	BOR	BOR	BOR	BOR	BOR	BOR	BOR	BOR	BOR
BOR	BAND	BAND	BAND	BAND	BAND	BAND	BAND	BAND	BAND	BAND	BAND	BAND	BAND	BAND	BAND	BAND																																																																				
BOR	BXOR	BXOR	BXOR	BXOR	BXOR	BXOR	BXOR	BXOR	BXOR	BXOR	BXOR	BXOR	BXOR	BXOR	BXOR	BXOR																																																																				
BOR	BOR	BIAND	BIAND	BIAND	BIAND	BIAND	BIAND	BIAND	BIAND	BIAND	BIAND	BIAND	BIAND	BIAND	BIAND	BIAND																																																																				
BOR	BOR	BOR	BOR	BOR	BOR	BOR	BOR	BOR	BOR	BOR	BOR	BOR	BOR	BOR	BOR	BOR																																																																				
8	ADD																																																																																			
9	ADDX																																																																																			
A	CMP																																																																																			
B	SUBX																																																																																			
C	OR																																																																																			
D	XOR																																																																																			
E	AND																																																																																			
F	MOV																																																																																			

**Table A.2 Operation Code Map (2)**

Instruction code: 

1st byte		2nd byte	
AH	AL	BH	BL

BH AH AL	0	1	2	3	4	5	6	7	8	9	A	B	C	D	E	F
01	MOV				LDC/STC				SLEEP				Table A.2 (3)	Table A.2 (3)		Table A.2 (3)
0A	INC	ADD														
0B	ADDS					INC		INC	ADDS					INC		INC
0F	DAA	MOV														
10	SHLL			SHLL					SHAL					SHAL		
11	SHLR			SHLR					SHAR					SHAR		
12	ROTXL			ROTXL					ROTL					ROTL		
13	ROTXR			ROTXR					ROTR					ROTR		
17	NOT			NOT				EXTU	NEG					NEG		EXTS
1A	DEC	SUB														
1B	SUBS					DEC		DEC	SUBS					DEC		DEC
1F	DAS	CMP														
58	BRA	BRN	BHI	BLS	BCC	BCS	BNE	BEQ	BVC	BVS	BPL	BMI	BGE	BLT	BGT	BLE
79	MOV	ADD	CMP	SUB	OR	XOR	AND									
7A	MOV	ADD	CMP	SUB	OR	XOR	AND									

**Table A.2 Operation Code Map (3)**

Instruction code: 

1st byte		2nd byte		3rd byte		4th byte	
AH	AL	BH	BL	CH	CL	DH	DL

CL AH ALBH BLCH	0	1	2	3	4	5	6	7	8	9	A	B	C	D	E	F
01406	LDC															
01C05	MULXS	MULXS														
01D05	DIVIXS			DIVXS												
01F06					OR	XOR	AND									
7C-r06 *1	BTST															
7C-r07 *1					BOR	BXOR	BAND	BLD	BIOR		BIXOR	BIAND	BILD	BST		
7D-r06 *1	BSET	BNOT		BCLR												
7D-r07 *1	BSET	BNOT		BCLR												
7Eaa6 *2	BTST															
7Eaa7 *2					BOR	BXOR	BAND	BLD	BIOR		BIXOR	BIAND	BILD	BST		
7Faa6 *2	BSET	BNOT		BCLR												
7Faa7 *2	BSET	BNOT		BCLR												

Notes: 1. r is the register designation field.  
 2. aa is the absolute address field.

## A.3 Number of States Required for Execution

The tables in this section can be used to calculate the number of states required for instruction execution by the H8/300H CPU. Table A.4 indicates the number of instruction fetch, data read/write, and other cycles occurring in each instruction. Table A.3 indicates the number of states required per cycle according to the bus size. The number of states required for execution of an instruction can be calculated from these two tables as follows:

$$\text{Number of states} = I \times S_I + J \times S_J + K \times S_K + L \times S_L + M \times S_M + N \times S_N$$

### Examples of Calculation of Number of States Required for Execution

**Examples:** Advanced mode, stack located in external address space, on-chip supporting modules accessed with 8-bit bus width, external devices accessed in three states with one wait state and 16-bit bus width.

BSET #0, @FFFFC7:8

From table A.4,  $I = L = 2$  and  $J = K = M = N = 0$

From table A.3,  $S_I = 4$  and  $S_L = 3$

Number of states =  $2 \times 4 + 2 \times 3 = 14$

JSR @@30

From table A.4,  $I = J = K = 2$  and  $L = M = N = 0$

From table A.3,  $S_I = S_J = S_K = 4$

Number of states =  $2 \times 4 + 2 \times 4 + 2 \times 4 = 24$

**Table A.3 Number of States per Cycle**

Execution State (Cycle)		Access Conditions						
		On-Chip Memory	On-Chip Sup- porting Module		External Device			
			8-Bit Bus	16-Bit Bus	8-Bit Bus		16-Bit Bus	
				2-State Access	3-State Access	2-State Access	3-State Access	
Instruction fetch	$S_I$	2	6	3	4	6 + 2m	2	3 + m
Branch address read	$S_J$							
Stack operation	$S_K$							
Byte data access	$S_L$		3		2	3 + m		
Word data access	$S_M$		6		4	6 + 2m		
Internal operation	$S_N$	1						

Legend

m: Number of wait states inserted into external device access



**Table A.4 Number of Cycles per Instruction**

Instruction	Mnemonic	Instruction	Branch	Stack	Byte Data	Word Data	Internal
		Fetch	Addr. Read	Operation	Access	Access	Operation
		I	J	K	L	M	N
ADD	ADD.B #xx:8, Rd	1					
	ADD.B Rs, Rd	1					
	ADD.W #xx:16, Rd	2					
	ADD.W Rs, Rd	1					
	ADD.L #xx:32, ERd	3					
	ADD.L ERs, ERd	1					
ADDS	ADDS #1/2/4, ERd	1					
ADDX	ADDX #xx:8, Rd	1					
	ADDX Rs, Rd	1					
AND	AND.B #xx:8, Rd	1					
	AND.B Rs, Rd	1					
	AND.W #xx:16, Rd	2					
	AND.W Rs, Rd	1					
	AND.L #xx:32, ERd	3					
	AND.L ERs, ERd	2					
ANDC	ANDC #xx:8, CCR	1					
BAND	BAND #xx:3, Rd	1					
	BAND #xx:3, @ERd	2			1		
	BAND #xx:3, @aa:8	2			1		
Bcc	BRA d:8 (BT d:8)	2					
	BRN d:8 (BF d:8)	2					
	BHI d:8	2					
	BLS d:8	2					
	BCC d:8 (BHS d:8)	2					
	BCS d:8 (BLO d:8)	2					
	BNE d:8	2					
	BEQ d:8	2					
	BVC d:8	2					
	BVS d:8	2					
	BPL d:8	2					
	BMI d:8	2					
	BGE d:8	2					
	BLT d:8	2					
	BGT d:8	2					
BLE d:8	2						

**Table A.4 Number of Cycles per Instruction (cont)**

Instruction	Mnemonic	Instruction	Branch	Stack	Byte Data	Word Data	Internal
		Fetch	Addr. Read	Operation	Access	Access	Operation
		I	J	K	L	M	N
Bcc	BRA d:16 (BT d:16)	2					2
	BRN d:16 (BF d:16)	2					2
	BHI d:16	2					2
	BLS d:16	2					2
	BCC d:16 (BHS d:16)	2					2
	BCS d:16 (BLO d:16)	2					2
	BNE d:16	2					2
	BEQ d:16	2					2
	BVC d:16	2					2
	BVS d:16	2					2
	BPL d:16	2					2
	BMI d:16	2					2
	BGE d:16	2					2
	BLT d:16	2					2
	BGT d:16	2					2
BLE d:16	2					2	
BCLR	BCLR #xx:3, Rd	1					
	BCLR #xx:3, @ERd	2			2		
	BCLR #xx:3, @aa:8	2			2		
	BCLR Rn, Rd	1					
	BCLR Rn, @ERd	2			2		
	BCLR Rn, @aa:8	2			2		
BIAND	BIAND #xx:3, Rd	1					
	BIAND #xx:3, @ERd	2			1		
	BIAND #xx:3, @aa:8	2			1		
BILD	BILD #xx:3, Rd	1					
	BILD #xx:3, @ERd	2			1		
	BILD #xx:3, @aa:8	2			1		
BIOR	BIOR #xx:8, Rd	1					
	BIOR #xx:8, @ERd	2			1		
	BIOR #xx:8, @aa:8	2			1		
BIST	BIST #xx:3, Rd	1					
	BIST #xx:3, @ERd	2			2		
	BIST #xx:3, @aa:8	2			2		
BIXOR	BIXOR #xx:3, Rd	1					
	BIXOR #xx:3, @ERd	2			1		
	BIXOR #xx:3, @aa:8	2			1		
BLD	BLD #xx:3, Rd	1					
	BLD #xx:3, @ERd	2			1		
	BLD #xx:3, @aa:8	2			1		

**Table A.4 Number of Cycles per Instruction (cont)**

Instruction	Mnemonic	Instruction		Branch	Stack	Byte Data	Word Data	Internal	
		Fetch	Addr. Read	Read	Operation	Access	Access	Operation	
		I	J	K	L	M	N		
BNOT	BNOT #xx:3, Rd	1							
	BNOT #xx:3, @ERd	2				2			
	BNOT #xx:3, @aa:8	2				2			
	BNOT Rn, Rd	1							
	BNOT Rn, @ERd	2				2			
	BNOT Rn, @aa:8	2				2			
BOR	BOR #xx:3, Rd	1							
	BOR #xx:3, @ERd	2				1			
	BOR #xx:3, @aa:8	2				1			
BSET	BSET #xx:3, Rd	1							
	BSET #xx:3, @ERd	2				2			
	BSET #xx:3, @aa:8	2				2			
	BSET Rn, Rd	1							
	BSET Rn, @ERd	2				2			
	BSET Rn, @aa:8	2				2			
BSR	BSR d:8	Normal	2		1				
		Advanced	2		2				
	BSR d:16	Normal	2		1			2	
		Advanced	2		2			2	
	BST	BST #xx:3, Rd	1						
		BST #xx:3, @ERd	2				2		
BST #xx:3, @aa:8		2				2			
BTST	BTST #xx:3, Rd	1							
	BTST #xx:3, @ERd	2				1			
	BTST #xx:3, @aa:8	2				1			
	BTST Rn, Rd	1							
	BTST Rn, @ERd	2				1			
	BTST Rn, @aa:8	2				1			
BXOR	BXOR #xx:3, Rd	1							
	BXOR #xx:3, @ERd	2				1			
	BXOR #xx:3, @aa:8	2				1			
CMP	CMP.B #xx:8, Rd	1							
	CMP.B Rs, Rd	1							
	CMP.W #xx:16, Rd	2							
	CMP.W Rs, Rd	1							
	CMP.L #xx:32, ERd	3							
	CMP.L ERs, ERd	1							
DAA	DAA Rd	1							
DAS	DAS Rd	1							

**Table A.4 Number of Cycles per Instruction (cont)**

Instruction Mnemonic		Instruction	Branch	Stack	Byte Data	Word Data	Internal	
		Fetch	Addr. Read	Operation	Access	Access	Operation	
		I	J	K	L	M	N	
DEC	DEC.B Rd	1						
	DEC.W #1/2, Rd	1						
	DEC.L #1/2, ERd	1						
DIVXS	DIVXS.B Rs, Rd	2					12	
	DIVXS.W Rs, ERd	2					20	
DIVXU	DIVXU.B Rs, Rd	1					12	
	DIVXU.W Rs, ERd	1					20	
EEPMOV	EEPMOV.B	2			$2n + 2^{*1}$			
	EEPMOV.W	2			$2n + 2^{*1}$			
EXTS	EXTS.W Rd	1						
	EXTS.L ERd	1						
EXTU	EXTU.W Rd	1						
	EXTU.L ERd	1						
INC	INC.B Rd	1						
	INC.W #1/2, Rd	1						
	INC.L #1/2, ERd	1						
JMP	JMP @ERn	2						
	JMP @aa:24	2					2	
	JMP @ @aa:8	Normal	2	1				2
		Advanced	2	2				2
JSR	JSR @ERn	Normal	2		1			
		Advanced	2		2			
	JSR @aa:24	Normal	2			1		2
		Advanced	2			2		2
	JSR @ @aa:8	Normal	2	1	1			
		Advanced	2	2	2			
	LDC	LDC #xx:8, CCR	1					
		LDC Rs, CCR	1					
LDC @ERs, CCR		2				1		
LDC @(d:16, ERs), CCR		3				1		
LDC @(d:24, ERs), CCR		5				1		
LDC @ERs+, CCR		2				1	2	
LDC @aa:16, CCR		3				1		
LDC @aa:24, CCR		4				1		

**Table A.4 Number of Cycles per Instruction (cont)**

Instruction Mnemonic	Instruction	Branch	Stack	Byte Data	Word Data	Internal	
							Fetch
	I	J	K	L	M	N	
MOV	MOV.B #xx:8, Rd	1					
	MOV.B Rs, Rd	1					
	MOV.B @ERs, Rd	1			1		
	MOV.B @(d:16, ERs), Rd	2			1		
	MOV.B @(d:24, ERs), Rd	4			1		
	MOV.B @ERs+, Rd	1			1	2	
	MOV.B @aa:8, Rd	1			1		
	MOV.B @aa:16, Rd	2			1		
	MOV.B @aa:24, Rd	3			1		
	MOV.B Rs, @ERd	1			1		
	MOV.B Rs, @(d:16, ERd)	2			1		
	MOV.B Rs, @(d:24, ERd)	4			1		
	MOV.B Rs, @-ERd	1			1	2	
	MOV.B Rs, @aa:8	1			1		
	MOV.B Rs, @aa:16	2			1		
	MOV.B Rs, @aa:24	3			1		
	MOV.W #xx:16, Rd	2					
	MOV.W Rs, Rd	1					
	MOV.W @ERs, Rd	1				1	
	MOV.W @(d:16, ERs), Rd	2				1	
	MOV.W @(d:24, ERs), Rd	4				1	
	MOV.W @ERs+, Rd	1				1	2
	MOV.W @aa:16, Rd	2				1	
	MOV.W @aa:24, Rd	3				1	
	MOV.W Rs, @ERd	1				1	
	MOV.W Rs, @(d:16, ERd)	2				1	
	MOV.W Rs, @(d:24, ERd)	4				1	
	MOV.W Rs, @-ERd	1				1	2
	MOV.W Rs, @aa:16	2				1	
	MOV.W Rs, @aa:24	3				1	
	MOV.L #xx:32, ERd	3					
	MOV.L ERs, ERd	1					
	MOV.L @ERs, ERd	2				2	
MOV.L @(d:16, ERs), ERd	3				2		
MOV.L @(d:24, ERs), ERd	5				2		
MOV.L @ERs+, ERd	2				2	2	
MOV.L @aa:16, ERd	3				2		
MOV.L @aa:24, ERd	4				2		
MOV.L ERs, @ERd	2				2		
MOV.L ERs, @(d:16, ERd)	3				2		
MOV.L ERs, @(d:24, ERd)	5				2		
MOV.L ERs, @-ERd	2				2	2	
MOV.L ERs, @aa:16	3				2		
MOV.L ERs, @aa:24	4				2		

**Table A.4 Number of Cycles per Instruction (cont)**

Instruction	Mnemonic	Instruction	Branch	Stack	Byte Data	Word Data	Internal
		Fetch	Addr. Read	Operation	Access	Access	Operation
		I	J	K	L	M	N
MOVFPE	MOVFPE @aa:16, Rd*2				1		
MOVTPE	MOVTPE Rs, @aa:16*2				1		
MULXS	MULXS.B Rs, Rd	2					12
	MULXS.W Rs, ERd	2					20
MULXU	MULXU.B Rs, Rd	1					12
	MULXU.W Rs, ERd	1					20
NEG	NEG.B Rd	1					
	NEG.W Rd	1					
	NEG.L ERd	1					
NOP	NOP	1					
NOT	NOT.B Rd	1					
	NOT.W Rd	1					
	NOT.L ERd	1					
OR	OR.B #xx:8, Rd	1					
	OR.B Rs, Rd	1					
	OR.W #xx:16, Rd	2					
	OR.W Rs, Rd	1					
	OR.L #xx:32, ERd	3					
	OR.L ERs, ERd	2					
ORC	ORC #xx:8, CCR	1					
POP	POP.W Rn	1				1	2
	POP.L ERn	2				2	2
PUSH	PUSH.W Rn	1				1	2
	PUSH.L ERn	2				2	2
ROTL	ROTL.B Rd	1					
	ROTL.W Rd	1					
	ROTL.L ERd	1					
ROTR	ROTR.B Rd	1					
	ROTR.W Rd	1					
	ROTR.L ERd	1					
ROTXL	ROTXL.B Rd	1					
	ROTXL.W Rd	1					
	ROTXL.L ERd	1					
ROTXR	ROTXR.B Rd	1					
	ROTXR.W Rd	1					
	ROTXR.L ERd	1					
RTE	RTE	2		2		2	

**Table A.4 Number of Cycles per Instruction (cont)**

Instruction	Mnemonic		Instruction	Branch	Stack	Byte Data	Word Data	Internal
			Fetch	Addr. Read	Operation	Access	Access	Operation
			I	J	K	L	M	N
RTS	RTS	Normal	2		1			2
		Advanced	2		2			2
SHAL	SHAL.B Rd		1					
	SHAL.W Rd		1					
	SHAL.L ERd		1					
SHAR	SHAR.B Rd		1					
	SHAR.W Rd		1					
	SHAR.L ERd		1					
SHLL	SHLL.B Rd		1					
	SHLL.W Rd		1					
	SHLL.L ERd		1					
SHLR	SHLR.B Rd		1					
	SHLR.W Rd		1					
	SHLR.L ERd		1					
SLEEP	SLEEP		1					
STC	STC CCR, Rd		1					
	STC CCR, @ERd		2				1	
	STC CCR, @(d:16, ERd)		3				1	
	STC CCR, @(d:24, ERd)		5				1	
	STC CCR, @-ERd		2				1	2
	STC CCR, @aa:16		3				1	
	STC CCR, @aa:24		4				1	
SUB	SUB.B Rs, Rd		1					
	SUB.W #xx:16, Rd		2					
	SUB.W Rs, Rd		1					
	SUB.L #xx:32, ERd		3					
	SUB.L ERs, ERd		1					
SUBS	SUBS #1/2/4, ERd		1					
SUBX	SUBX #xx:8, Rd		1					
	SUBX Rs, Rd		1					
TRAPA	TRAPA #x:2	Normal	2	1	2			4
		Advanced	2	2	2			4
XOR	XOR.B #xx:8, Rd		1					
	XOR.B Rs, Rd		1					
	XOR.W #xx:16, Rd		2					
	XOR.W Rs, Rd		1					
	XOR.L #xx:32, ERd		3					
	XOR.L ERs, ERd		2					
XORC	XORC #xx:8, CCR		1					

- Notes: 1. n is the value set in register R4L or R4. The source and destination are accessed n + 1 times each.
2. Not available in the H8/3067 Series.

# Appendix B Internal I/O Registers

## B.1 Addresses

Address (Low)	Register Name	Data Bus Width	Bit Names								Module Name
			Bit 7	Bit 6	Bit 5	Bit 4	Bit 3	Bit 2	Bit 1	Bit 0	
H'EE000	P1DDR	8	P1 <sub>7</sub> DDR	P1 <sub>6</sub> DDR	P1 <sub>5</sub> DDR	P1 <sub>4</sub> DDR	P1 <sub>3</sub> DDR	P1 <sub>2</sub> DDR	P1 <sub>1</sub> DDR	P1 <sub>0</sub> DDR	Port 1
H'EE001	P2DDR	8	P2 <sub>7</sub> DDR	P2 <sub>6</sub> DDR	P2 <sub>5</sub> DDR	P2 <sub>4</sub> DDR	P2 <sub>3</sub> DDR	P2 <sub>2</sub> DDR	P2 <sub>1</sub> DDR	P2 <sub>0</sub> DDR	Port 2
H'EE002	P3DDR	8	P3 <sub>7</sub> DDR	P3 <sub>6</sub> DDR	P3 <sub>5</sub> DDR	P3 <sub>4</sub> DDR	P3 <sub>3</sub> DDR	P3 <sub>2</sub> DDR	P3 <sub>1</sub> DDR	P3 <sub>0</sub> DDR	Port 3
H'EE003	P4DDR	8	P4 <sub>7</sub> DDR	P4 <sub>6</sub> DDR	P4 <sub>5</sub> DDR	P4 <sub>4</sub> DDR	P4 <sub>3</sub> DDR	P4 <sub>2</sub> DDR	P4 <sub>1</sub> DDR	P4 <sub>0</sub> DDR	Port 4
H'EE004	P5DDR	8	—	—	—	—	P5 <sub>3</sub> DDR	P5 <sub>2</sub> DDR	P5 <sub>1</sub> DDR	P5 <sub>0</sub> DDR	Port 5
H'EE005	P6DDR	8	—	P6 <sub>6</sub> DDR	P6 <sub>5</sub> DDR	P6 <sub>4</sub> DDR	P6 <sub>3</sub> DDR	P6 <sub>2</sub> DDR	P6 <sub>1</sub> DDR	P6 <sub>0</sub> DDR	Port 6
H'EE006	—	—	—	—	—	—	—	—	—	—	—
H'EE007	P8DDR	8	—	—	—	—	P8 <sub>7</sub> DDR	P8 <sub>6</sub> DDR	P8 <sub>5</sub> DDR	P8 <sub>4</sub> DDR	Port 8
H'EE008	P9DDR	8	—	—	—	—	P9 <sub>5</sub> DDR	P9 <sub>4</sub> DDR	P9 <sub>3</sub> DDR	P9 <sub>2</sub> DDR	Port 9
H'EE009	PADDR	8	PA <sub>7</sub> DDR	PA <sub>6</sub> DDR	PA <sub>5</sub> DDR	PA <sub>4</sub> DDR	PA <sub>3</sub> DDR	PA <sub>2</sub> DDR	PA <sub>1</sub> DDR	PA <sub>0</sub> DDR	Port A
H'EE00A	PBDDR	8	PB <sub>7</sub> DDR	PB <sub>6</sub> DDR	PB <sub>5</sub> DDR	PB <sub>4</sub> DDR	PB <sub>3</sub> DDR	PB <sub>2</sub> DDR	PB <sub>1</sub> DDR	PB <sub>0</sub> DDR	Port B
H'EE00B	—	—	—	—	—	—	—	—	—	—	—
H'EE00C	—	—	—	—	—	—	—	—	—	—	—
H'EE00D	—	—	—	—	—	—	—	—	—	—	—
H'EE00E	—	—	—	—	—	—	—	—	—	—	—
H'EE00F	—	—	—	—	—	—	—	—	—	—	—
H'EE010	—	—	—	—	—	—	—	—	—	—	—
H'EE011	MDCR	8	—	—	—	—	—	MDS2	MDS1	MDS0	System control
H'EE012	SYSCR	8	SSBY	STS2	STS1	STS0	UE	NMIEG	SSOE	RAME	System control
H'EE013	BRCR	8	A23E	A22E	A21E	A20E	—	—	—	BRLE	Bus controller
H'EE014	ISCR	8	—	—	IRQ5SC	IRQ4SC	IRQ3SC	IRQ2SC	IRQ1SC	IRQ0SC	Interrupt controller
H'EE015	IER	8	—	—	IRQ5E	IRQ4E	IRQ3E	IRQ2E	IRQ1E	IRQ0E	Interrupt controller
H'EE016	ISR	8	—	—	IRQ5F	IRQ4F	IRQ3F	IRQ2F	IRQ1F	IRQ0F	Interrupt controller
H'EE017	—	—	—	—	—	—	—	—	—	—	—
H'EE018	IPRA	8	IPRA7	IPRA6	IPRA5	IPRA4	IPRA3	IPRA2	IPRA1	IPRA0	—
H'EE019	IPRB	8	IPRB7	IPRB6	IPRB5	—	IPRB3	IPRB2	IPRB1	—	—
H'EE01A	DASTCR	8	—	—	—	—	—	—	—	DASTE	D/A converter
H'EE01B	DIVCR	8	—	—	—	—	—	—	DIV1	DIV0	System control
H'EE01C	MSTCRH	8	PSTOP	—	—	—	—	MSTPH2	MSTPH1	MSTPH0	System control
H'EE01D	MSTCRL	8	MSTPL7	—	MSTPL5	MSTPL4	MSTPL3	MSTPL2	—	MSTPL0	System control
H'EE01E	ADRCR*	8	—	—	—	—	—	—	—	ADRCTL	Bus controller
H'EE01F	CSCR	8	CS7E	CS6E	CS5E	CS4E	—	—	—	—	—

Note: \* The ADRCR register is provided only in the flash memory R version and mask ROM versions; it is not present in the flash memory version.



## B.1 Addresses (cont)

Address (Low)	Register Name	Data Bus Width	Bit Names								Module Name
			Bit 7	Bit 6	Bit 5	Bit 4	Bit 3	Bit 2	Bit 1	Bit 0	
H'EE020	ABWCR	8	ABW7	ABW6	ABW5	ABW4	ABW3	ABW2	ABW1	ABW0	Bus controller
H'EE021	ASTCR	8	AST7	AST6	AST5	AST4	AST3	AST2	AST1	AST0	
H'EE022	WCRH	8	W71	W70	W61	W60	W51	W50	W41	W40	
H'EE023	WCRL	8	W31	W30	W21	W20	W11	W10	W01	W00	
H'EE024	BCR	8	ICIS1	ICIS0	BROME	BRSTS1	BRSTS0	—	RDEA	WAITE	
H'EE025	—	—	—	—	—	—	—	—	—	—	
H'EE026	DRCRA	8	DRAS2	DRAS1	DRAS0	—	BE	RDM	SRFMD	RFSHE	DRAM Interface
H'EE027	DRCRB	8	MXC1	MXC0	CSEL	RCYCE	—	TPC	RCW	RLW	
H'EE028	RTMCSR	8	CMF	CMIE	CKS2	CKS1	CKS0	—	—	—	
H'EE029	RTCNT	8									
H'EE02A	RTCOR	8									
H'EE02B	Reserved area (access prohibited)										
H'EE02C											
H'EE02D											
H'EE02E											
H'EE02F											
H'EE030	FLMCR*	8	FWE	SWE	ESU	PSU	EV	PV	E	P	Flash memory
H'EE031	Reserved area (access prohibited)										
H'EE032	EBR*	8	EB7	EB6	EB5	EB4	EB3	EB2	EB1	EB0	
H'EE033	Reserved area (access prohibited)										
H'EE034	—	—	—	—	—	—	—	—	—	—	
H'EE035	—	—	—	—	—	—	—	—	—	—	
H'EE036	—	—	—	—	—	—	—	—	—	—	
H'EE037	—	—	—	—	—	—	—	—	—	—	
H'EE038	—	—	—	—	—	—	—	—	—	—	
H'EE039	—	—	—	—	—	—	—	—	—	—	
H'EE03A	—	—	—	—	—	—	—	—	—	—	
H'EE03B	—	—	—	—	—	—	—	—	—	—	
H'EE03C	P2PCR	8	P2 <sub>7</sub> PCR	P2 <sub>6</sub> PCR	P2 <sub>5</sub> PCR	P2 <sub>4</sub> PCR	P2 <sub>3</sub> PCR	P2 <sub>2</sub> PCR	P2 <sub>1</sub> PCR	P2 <sub>0</sub> PCR	Port 2
H'EE03D	—	—	—	—	—	—	—	—	—	—	
H'EE03E	P4PCR	8	P4 <sub>7</sub> PCR	P4 <sub>6</sub> PCR	P4 <sub>5</sub> PCR	P4 <sub>4</sub> PCR	P4 <sub>3</sub> PCR	P4 <sub>2</sub> PCR	P4 <sub>1</sub> PCR	P4 <sub>0</sub> PCR	Port 4
H'EE03F	P5PCR	8	—	—	—	—	P5 <sub>3</sub> PCR	P5 <sub>2</sub> PCR	P5 <sub>1</sub> PCR	P5 <sub>0</sub> PCR	Port 5

Note: \* The FLMCR and EBR registers are used only in the flash memory and flash memory R versions, and are not provided in the mask ROM versions.

## B.1 Addresses (cont)

Address (Low)	Register Name	Data Bus Width	Bit Names								Module Name
			Bit 7	Bit 6	Bit 5	Bit 4	Bit 3	Bit 2	Bit 1	Bit 0	
H'EE040	—	—	—	—	—	—	—	—	—	—	—
H'EE041	—	—	—	—	—	—	—	—	—	—	—
H'EE042	—	—	—	—	—	—	—	—	—	—	—
H'EE043	—	—	—	—	—	—	—	—	—	—	—
H'EE044	—	—	—	—	—	—	—	—	—	—	—
H'EE045	—	—	—	—	—	—	—	—	—	—	—
H'EE046	—	—	—	—	—	—	—	—	—	—	—
H'EE047	—	—	—	—	—	—	—	—	—	—	—
H'EE048	—	—	—	—	—	—	—	—	—	—	—
H'EE049	—	—	—	—	—	—	—	—	—	—	—
H'EE04A	—	—	—	—	—	—	—	—	—	—	—
H'EE04B	—	—	—	—	—	—	—	—	—	—	—
H'EE04C	—	—	—	—	—	—	—	—	—	—	—
H'EE04D	—	—	—	—	—	—	—	—	—	—	—
H'EE04E	—	—	—	—	—	—	—	—	—	—	—
H'EE04F	—	—	—	—	—	—	—	—	—	—	—
H'EE050	—	—	—	—	—	—	—	—	—	—	—
H'EE051	—	—	—	—	—	—	—	—	—	—	—
H'EE052	—	—	—	—	—	—	—	—	—	—	—
H'EE053	—	—	—	—	—	—	—	—	—	—	—
H'EE054	—	—	—	—	—	—	—	—	—	—	—
H'EE055	—	—	—	—	—	—	—	—	—	—	—
H'EE056	—	—	—	—	—	—	—	—	—	—	—
H'EE057	—	—	—	—	—	—	—	—	—	—	—
H'EE058	—	—	—	—	—	—	—	—	—	—	—
H'EE059	—	—	—	—	—	—	—	—	—	—	—
H'EE05A	—	—	—	—	—	—	—	—	—	—	—
H'EE05B	—	—	—	—	—	—	—	—	—	—	—
H'EE05C	—	—	—	—	—	—	—	—	—	—	—
H'EE05D	—	—	—	—	—	—	—	—	—	—	—
H'EE05E	—	—	—	—	—	—	—	—	—	—	—
H'EE05F	—	—	—	—	—	—	—	—	—	—	—

## B.1 Addresses (cont)

Address (Low)	Register Name	Data Bus Width	Bit Names								Module Name
			Bit 7	Bit 6	Bit 5	Bit 4	Bit 3	Bit 2	Bit 1	Bit 0	
H'EE060	—	—	—	—	—	—	—	—	—	—	—
H'EE061	—	—	—	—	—	—	—	—	—	—	—
H'EE062	—	—	—	—	—	—	—	—	—	—	—
H'EE063	—	—	—	—	—	—	—	—	—	—	—
H'EE064	—	—	—	—	—	—	—	—	—	—	—
H'EE065	—	—	—	—	—	—	—	—	—	—	—
H'EE066	—	—	—	—	—	—	—	—	—	—	—
H'EE067	—	—	—	—	—	—	—	—	—	—	—
H'EE068	—	—	—	—	—	—	—	—	—	—	—
H'EE069	—	—	—	—	—	—	—	—	—	—	—
H'EE06A	—	—	—	—	—	—	—	—	—	—	—
H'EE06B	—	—	—	—	—	—	—	—	—	—	—
H'EE06C	—	—	—	—	—	—	—	—	—	—	—
H'EE06D	—	—	—	—	—	—	—	—	—	—	—
H'EE06E	—	—	—	—	—	—	—	—	—	—	—
H'EE06F	—	—	—	—	—	—	—	—	—	—	—
H'EE070	—	—	—	—	—	—	—	—	—	—	—
H'EE071	—	—	—	—	—	—	—	—	—	—	—
H'EE072	—	—	—	—	—	—	—	—	—	—	—
H'EE073	—	—	—	—	—	—	—	—	—	—	—
H'EE074	Reserved area (access prohibited)										
H'EE075											
H'EE076											
H'EE077	RAMCR* 8	—	—	—	—	—	RAMS	RAM2	RAM1	—	Flash memory*
H'EE078	Reserved area (access prohibited)										
H'EE079											
H'EE07A											
H'EE07B											
H'EE07C											
H'EE07D	FLMSR* 8	FLER	—	—	—	—	—	—	—	—	—
H'EE07E	Reserved area (access prohibited)										
H'EE07F											
H'EE080											
H'EE081											

Note: \* The RAMCR and FLMSR registers are used only in the flash memory and flash memory R versions, and are not provided in the mask ROM versions.

## B.1 Addresses (cont)

Address (Low)	Register Name	Data Bus Width	Bit Names								Module Name
			Bit 7	Bit 6	Bit 5	Bit 4	Bit 3	Bit 2	Bit 1	Bit 0	
H'FFF20	MAR0AR	8									DMAC channel 0A
H'FFF21	MAR0AE	8									
H'FFF22	MAR0AH	8									
H'FFF23	MAR0AL	8									
H'FFF24	ETCR0AH	8									
H'FFF25	ETCR0AL	8									
H'FFF26	IOAR0A	8									
H'FFF27	DTCR0A	8	DTE	DTSZ	DTID	RPE	DTIE	DTS2	DTS1	DTS0	Short address mode
			DTE	DTSZ	SAID	SAIDE	DTIE	DTS2A	DTS1A	DTS0A	Full address mode
H'FFF28	MAR0BR	8									DMAC channel 0B
H'FFF29	MAR0BE	8									
H'FFF2A	MAR0BH	8									
H'FFF2B	MAR0BL	8									
H'FFF2C	ETCR0BH	8									
H'FFF2D	ETCR0BL	8									
H'FFF2E	IOAR0B	8									
H'FFF2F	DTCR0B	8	DTE	DTSZ	DTID	RPE	DTIE	DTS2	DTS1	DTS0	Short address mode
			DTME	—	DAID	DAIDE	TMS	DTS2B	DTS1B	DTS0B	Full address mode
H'FFF30	MAR1AR	8									DMAC channel 1A
H'FFF31	MAR1AE	8									
H'FFF32	MAR1AH	8									
H'FFF33	MAR1AL	8									
H'FFF34	ETCR1AH	8									
H'FFF35	ETCR1AL	8									
H'FFF36	IOAR1A	8									
H'FFF37	DTCR1A	8	DTE	DTSZ	DTID	RPE	DTIE	DTS2	DTS1	DTS0	Short address mode
			DTE	DTSZ	SAID	SAIDE	DTIE	DTS2A	DTS1A	DTS0A	Full address mode
H'FFF38	MAR1BR	8									DMAC channel 1B
H'FFF39	MAR1BE	8									
H'FFF3A	MAR1BH	8									
H'FFF3B	MAR1BL	8									
H'FFF3C	ETCR1BH	8									
H'FFF3D	ETCR1BL	8									
H'FFF3E	IOAR1B	8									
H'FFF3F	DTCR1B	8	DTE	DTSZ	DTID	RPE	DTIE	DTS2	DTS1	DTS0	Short address mode
			DTME	—	DAID	DAIDE	TMS	DTS2B	DTS1B	DTS0B	Full address mode

## B.1 Addresses (cont)

Address (Low)	Register Name	Data Bus Width	Bit Names								Module Name
			Bit 7	Bit 6	Bit 5	Bit 4	Bit 3	Bit 2	Bit 1	Bit 0	
H'FFF40	—	—	—	—	—	—	—	—	—	—	—
H'FFF41	—	—	—	—	—	—	—	—	—	—	—
H'FFF42	—	—	—	—	—	—	—	—	—	—	—
H'FFF43	—	—	—	—	—	—	—	—	—	—	—
H'FFF44	—	—	—	—	—	—	—	—	—	—	—
H'FFF45	—	—	—	—	—	—	—	—	—	—	—
H'FFF46	—	—	—	—	—	—	—	—	—	—	—
H'FFF47	—	—	—	—	—	—	—	—	—	—	—
H'FFF48	—	—	—	—	—	—	—	—	—	—	—
H'FFF49	—	—	—	—	—	—	—	—	—	—	—
H'FFF4A	—	—	—	—	—	—	—	—	—	—	—
H'FFF4B	—	—	—	—	—	—	—	—	—	—	—
H'FFF4C	—	—	—	—	—	—	—	—	—	—	—
H'FFF4D	—	—	—	—	—	—	—	—	—	—	—
H'FFF4E	—	—	—	—	—	—	—	—	—	—	—
H'FFF4F	—	—	—	—	—	—	—	—	—	—	—
H'FFF50	—	—	—	—	—	—	—	—	—	—	—
H'FFF51	—	—	—	—	—	—	—	—	—	—	—
H'FFF52	—	—	—	—	—	—	—	—	—	—	—
H'FFF53	—	—	—	—	—	—	—	—	—	—	—
H'FFF54	—	—	—	—	—	—	—	—	—	—	—
H'FFF55	—	—	—	—	—	—	—	—	—	—	—
H'FFF56	—	—	—	—	—	—	—	—	—	—	—
H'FFF57	—	—	—	—	—	—	—	—	—	—	—
H'FFF58	—	—	—	—	—	—	—	—	—	—	—
H'FFF59	—	—	—	—	—	—	—	—	—	—	—
H'FFF5A	—	—	—	—	—	—	—	—	—	—	—
H'FFF5B	—	—	—	—	—	—	—	—	—	—	—
H'FFF5C	—	—	—	—	—	—	—	—	—	—	—
H'FFF5D	—	—	—	—	—	—	—	—	—	—	—
H'FFF5E	—	—	—	—	—	—	—	—	—	—	—
H'FFF5F	—	—	—	—	—	—	—	—	—	—	—

## B.1 Addresses (cont)

Address (Low)	Register Name	Data Bus Width	Bit Names								Module Name	
			Bit 7	Bit 6	Bit 5	Bit 4	Bit 3	Bit 2	Bit 1	Bit 0		
H'FFF60	TSTR	8	—	—	—	—	—	—	STR2	STR1	STR0	16-bit timer, (all channels)
H'FFF61	TSNC	8	—	—	—	—	—	—	SYNC2	SYNC1	SYNC0	
H'FFF62	TMDR	8	—	MDF	FDIR	—	—	—	PWM2	PWM1	PWM0	
H'FFF63	TOLR	8	—	—	TOB2	TOA2	TOB1	TOA1	TOB0	TOA0		
H'FFF64	TISRA	8	—	IMIEA2	IMIEA1	IMIEA0	—	—	IMFA2	IMFA1	IMFA0	
H'FFF65	TISRB	8	—	IMIEB2	IMIEB1	IMIEB0	—	—	IMFB2	IMFB1	IMFB0	
H'FFF66	TISRC	8	—	OVIE2	OVIE1	OVIE0	—	—	OVF2	OVF1	OVF0	
H'FFF67												
H'FFF68	TCR0	8	—	CCLR1	CCLR0	CKEG1	CKEG0	TPSC2	TPSC1	TPSC0	16-bit timer channel 0	
H'FFF69	TIOR0	8	—	IOB2	IOB1	IOB0	—	IOA2	IOA1	IOA0		
H'FFF6A	TCNT0H	16										
H'FFF6B	TCNT0L											
H'FFF6C	GRA0H	16										
H'FFF6D	GRA0L											
H'FFF6E	GRB0H	16										
H'FFF6F	GRB0L											
H'FFF70	TCR1	8	—	CCLR1	CCLR0	CKEG1	CKEG0	TPSC2	TPSC1	TPSC0	16-bit timer channel 1	
H'FFF71	TIOR1	8	—	IOB2	IOB1	IOB0	—	IOA2	IOA1	IOA0		
H'FFF72	TCNT1H	16										
H'FFF73	TCNT1L											
H'FFF74	GRA1H	16										
H'FFF75	GRA1L											
H'FFF76	GRB1H	16										
H'FFF77	GRB1L											
H'FFF78	TCR2	8	—	CCLR1	CCLR0	CKEG1	CKEG0	TPSC2	TPSC1	TPSC0	16-bit timer channel 2	
H'FFF79	TIOR2	8	—	IOB2	IOB1	IOB0	—	IOA2	IOA1	IOA0		
H'FFF7A	TCNT2H	16										
H'FFF7B	TCNT2L											
H'FFF7C	GRA2H	16										
H'FFF7D	GRA2L											
H'FFF7E	GRB2H	16										
H'FFF7F	GRB2L											

## B.1 Addresses (cont)

Address (Low)	Register Name	Data Bus Width	Bit Names								Module Name
			Bit 7	Bit 6	Bit 5	Bit 4	Bit 3	Bit 2	Bit 1	Bit 0	
H'FFF80	TCR0	8	CMIEB	CMIEA	OVIE	CCLR1	CCLR0	CKS2	CKS1	CKS0	8-bit timer channels 0 and 1
H'FFF81	TCR1	8	CMIEB	CMIEA	OVIE	CCLR1	CCLR0	CKS2	CKS1	CKS0	
H'FFF82	TCSR0	8	CMFB	CMFA	OVF	ADTE	OIS3	OIS2	OS1	OS0	
H'FFF83	TCSR1	8	CMFB	CMFA	OVF	ICE	OIS3	OIS2	OS1	OS0	
H'FFF84	TCORA0	8									
H'FFF85	TCORA1	8									
H'FFF86	TCORB0	8									
H'FFF87	TCORB1	8									
H'FFF88	TCNT0	8									
H'FFF89	TCNT1	8									
H'FFF8A	—	—	—	—	—	—	—	—	—	—	
H'FFF8B	—	—	—	—	—	—	—	—	—	—	
H'FFF8C	TCSR*	8	OVF	WT/IT	TME	—	—	CKS2	CKS1	CKS0	WDT
H'FFF8D	TCNT*	8									
H'FFF8E	—	—	—	—	—	—	—	—	—	—	
H'FFF8F	RSTCSR*	8	WRST	RSTOE	—	—	—	—	—	—	
H'FFF90	TCR2	8	CMIEB	CMIEA	OVIE	CCLR1	CCLR0	CKS2	CKS1	CKS0	8-bit timer channels 2 and 3
H'FFF91	TCR3	8	CMIEB	CMIEA	OVIE	CCLR1	CCLR0	CKS2	CKS1	CKS0	
H'FFF92	TCSR2	8	CMFB	CMFA	OVF	—	OIS3	OIS2	OS1	OS0	
H'FFF93	TCSR3	8	CMFB	CMFA	OVF	ICE	OIS3	OIS2	OS1	OS0	
H'FFF94	TCORA2	8									
H'FFF95	TCORA3	8									
H'FFF96	TCORB2	8									
H'FFF97	TCORB3	8									
H'FFF98	TCNT2	8									
H'FFF99	TCNT3	8									
H'FFF9A	—	—	—	—	—	—	—	—	—	—	
H'FFF9B	—	—	—	—	—	—	—	—	—	—	
H'FFF9C	DADR0	8									D/A converter
H'FFF9D	DADR1	8									
H'FFF9E	DACR	8	DAOE1	DAOE0	DAE	—	—	—	—	—	
H'FFF9F	—	8	—	—	—	—	—	—	—	—	

Note: \* For write access to TCSR, TCNT, and RSTCSR, see section 12.2.4, Notes on Register Access.

### Legend

WDT: Watchdog timer

## B.1 Addresses (cont)

Address (Low)	Register Name	Data Bus Width	Bit Names								Module Name
			Bit 7	Bit 6	Bit 5	Bit 4	Bit 3	Bit 2	Bit 1	Bit 0	
H'FFFA0	TPMR	8	—	—	—	—	G3NOV	G2NOV	G1NOV	G0NOV	TPC
H'FFFA1	TPCR	8	G3CMS1	G3CMS0	G2CMS1	G2CMS0	G1CMS1	G1CMS0	G0CMS1	G0CMS0	
H'FFFA2	NDERB	8	NDER15	NDER14	NDER13	NDER12	NDER11	NDER10	NDER9	NDER8	
H'FFFA3	NDERA	8	NDER7	NDER6	NDER5	NDER4	NDER3	NDER2	NDER1	NDER0	
H'FFFA4	NDRB*	8	NDER15	NDER14	NDER13	NDER12	NDER11	NDER10	NDER9	NDER8	
			NDER15	NDER14	NDER13	NDER12	—	—	—	—	
H'FFFA5	NDRA*	8	NDER7	NDER6	NDER5	NDER4	NDER3	NDER2	NDER1	NDER0	
			NDER7	NDER6	NDER5	NDER4	—	—	—	—	
H'FFFA6	NDRB*	8	—	—	—	—	—	—	—	—	
			—	—	—	—	NDER11	NDER10	NDER9	NDER8	
H'FFFA7	NDRA*	8	—	—	—	—	—	—	—	—	
			—	—	—	—	NDER3	NDER2	NDER1	NDER0	
H'FFFA8											
H'FFFA9											
H'FFFAA											
H'FFFAB											
H'FFFAC											
H'FFFAD											
H'FFFAE											
H'FFFAF											
H'FFFB0	SMR	8	C/ $\bar{A}$	CHR	PE	O/ $\bar{E}$	STOP	MP	CKS1	CKS0	SCI channel 0
H'FFFB1	BRR	8									
H'FFFB2	SCR	8	TIE	RIE	TE	RE	MPIE	TEIE	CKE1	CKE0	
H'FFFB3	TDR	8									
H'FFFB4	SSR	8	TDRE	RDRF	ORER	FER/ERS	PER	TEND	MPB	MPBT	
H'FFFB5	RDR	8									
H'FFFB6	SCMR	8	—	—	—	—	SDIR	SINV	—	SMIF	
H'FFFB7	Reserved area (access prohibited)										
H'FFFB8	SMR	8	C/ $\bar{A}$	CHR	PE	O/ $\bar{E}$	STOP	MP	CKS1	CKS0	SCI channel 1
H'FFFB9	BRR	8									
H'FFBBA	SCR	8	TIE	RIE	TE	RE	MPIE	TEIE	CKE1	CKE0	
H'FFBBB	TDR	8									
H'FFBBC	SSR	8	TDRE	RDRF	ORER	FER/ERS	PER	TEND	MPB	MPBT	
H'FFBBD	RDR	8									
H'FFBBE	SCMR	8	—	—	—	—	SDIR	SINV	—	SMIF	
H'FFBBF	Reserved area (access prohibited)										

Note: \* The address depends on the output trigger setting.

### Legend

TPC: Programmable timing pattern controller

SCI: Serial communication interface



## B.1 Addresses (cont)

Address (Low)	Register Name	Data Bus Width	Bit Names								Module Name
			Bit 7	Bit 6	Bit 5	Bit 4	Bit 3	Bit 2	Bit 1	Bit 0	
H'FFFC0	SMR	8	C/ $\bar{A}$	CHR	PE	O/ $\bar{E}$	STOP	MP	CKS1	CKS0	SCI channel 2
H'FFFC1	BRR	8									
H'FFFC2	SCR	8	TIE	RIE	TE	RE	MPIE	TEIE	CKE1	CKE0	
H'FFFC3	TDR	8									
H'FFFC4	SSR	8	TDRE	RDRF	ORER	FER/ERS	PER	TEND	MPB	MPBT	
H'FFFC5	RDR	8									
H'FFFC6	SCMR	8	—	—	—	—	SDIR	SINV	—	SMIF	
H'FFFC7	Reserved area (access prohibited)										
H'FFFC8	—	—	—	—	—	—	—	—	—	—	
H'FFFC9	—	—	—	—	—	—	—	—	—	—	
H'FFFCa	—	—	—	—	—	—	—	—	—	—	
H'FFFCb	—	—	—	—	—	—	—	—	—	—	
H'FFFCc	—	—	—	—	—	—	—	—	—	—	
H'FFFCd	—	—	—	—	—	—	—	—	—	—	
H'FFFCe	—	—	—	—	—	—	—	—	—	—	
H'FFFCf	—	—	—	—	—	—	—	—	—	—	
H'FFFD0	P1DR	8	P1 <sub>7</sub>	P1 <sub>6</sub>	P1 <sub>5</sub>	P1 <sub>4</sub>	P1 <sub>3</sub>	P1 <sub>2</sub>	P1 <sub>1</sub>	P1 <sub>0</sub>	Port1
H'FFFD1	P2DR	8	P2 <sub>7</sub>	P2 <sub>6</sub>	P2 <sub>5</sub>	P2 <sub>4</sub>	P2 <sub>3</sub>	P2 <sub>2</sub>	P2 <sub>1</sub>	P2 <sub>0</sub>	Port2
H'FFFD2	P3DR	8	P3 <sub>7</sub>	P3 <sub>6</sub>	P3 <sub>5</sub>	P3 <sub>4</sub>	P3 <sub>3</sub>	P3 <sub>2</sub>	P3 <sub>1</sub>	P3 <sub>0</sub>	Port3
H'FFFD3	P4DR	8	P4 <sub>7</sub>	P4 <sub>6</sub>	P4 <sub>5</sub>	P4 <sub>4</sub>	P4 <sub>3</sub>	P4 <sub>2</sub>	P4 <sub>1</sub>	P4 <sub>0</sub>	Port4
H'FFFD4	P5DR	8	—	—	—	—	P5 <sub>3</sub>	P5 <sub>2</sub>	P5 <sub>1</sub>	P5 <sub>0</sub>	Port5
H'FFFD5	P6DR	8	P6 <sub>7</sub>	P6 <sub>6</sub>	P6 <sub>5</sub>	P6 <sub>4</sub>	P6 <sub>3</sub>	P6 <sub>2</sub>	P6 <sub>1</sub>	P6 <sub>0</sub>	Port6
H'FFFD6	P7DR	8	P7 <sub>7</sub>	P7 <sub>6</sub>	P7 <sub>5</sub>	P7 <sub>4</sub>	P7 <sub>3</sub>	P7 <sub>2</sub>	P7 <sub>1</sub>	P7 <sub>0</sub>	Port7
H'FFFD7	P8DR	8	—	—	—	P8 <sub>4</sub>	P8 <sub>3</sub>	P8 <sub>2</sub>	P8 <sub>1</sub>	P8 <sub>0</sub>	Port8
H'FFFD8	P9DR	8	—	—	P9 <sub>5</sub>	P9 <sub>4</sub>	P9 <sub>3</sub>	P9 <sub>2</sub>	P9 <sub>1</sub>	P9 <sub>0</sub>	Port9
H'FFFD9	PADR	8	PA <sub>7</sub>	PA <sub>6</sub>	PA <sub>5</sub>	PA <sub>4</sub>	PA <sub>3</sub>	PA <sub>2</sub>	PA <sub>1</sub>	PA <sub>0</sub>	PortA
H'FFFDa	PBDR	8	PB <sub>7</sub>	PB <sub>6</sub>	PB <sub>5</sub>	PB <sub>4</sub>	PB <sub>3</sub>	PB <sub>2</sub>	PB <sub>1</sub>	PB <sub>0</sub>	PortB
H'FFFDb	—	—	—	—	—	—	—	—	—	—	
H'FFFDc	—	—	—	—	—	—	—	—	—	—	
H'FFFDd	—	—	—	—	—	—	—	—	—	—	
H'FFFD e	—	—	—	—	—	—	—	—	—	—	
H'FFFDf	—	—	—	—	—	—	—	—	—	—	

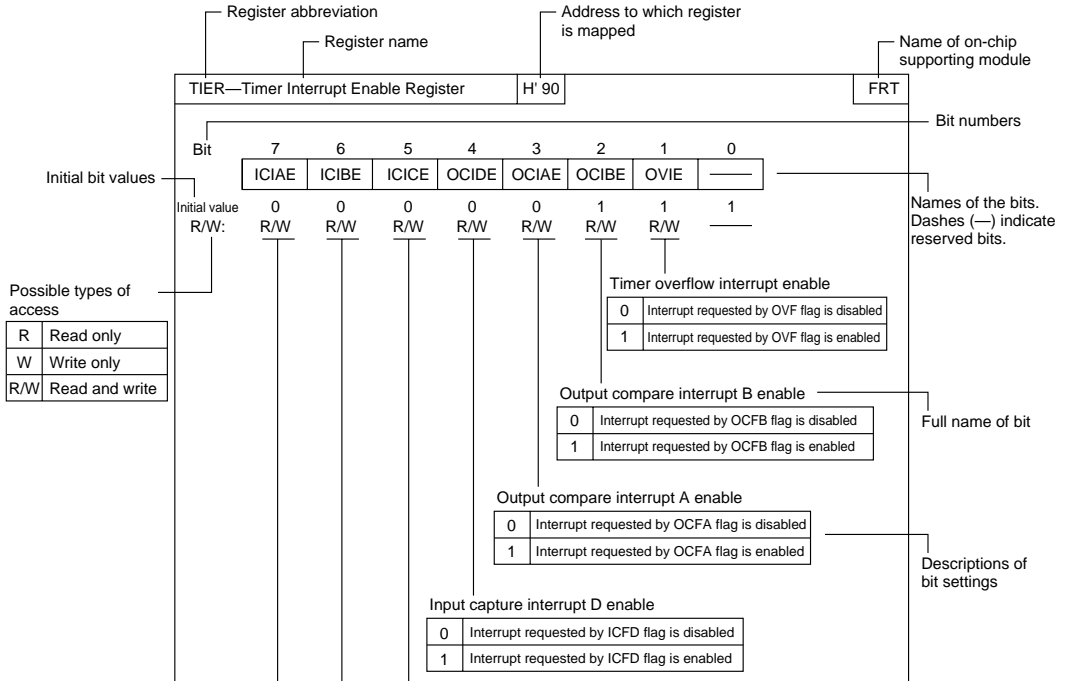
### Legend

SCI: Serial communication interface

## B.1 Addresses (cont)

Address (Low)	Register Name	Data Bus Width	Bit Names								Module Name
			Bit 7	Bit 6	Bit 5	Bit 4	Bit 3	Bit 2	Bit 1	Bit 0	
H'FFFE0	ADDRAH	8	AD9	AD8	AD7	AD6	AD5	AD4	AD3	AD2	A/D converter
H'FFFE1	ADDRAL	8	AD1	AD0	—	—	—	—	—	—	
H'FFFE2	ADDRBH	8	AD9	AD8	AD7	AD6	AD5	AD4	AD3	AD2	
H'FFFE3	ADDRBL	8	AD1	AD0	—	—	—	—	—	—	
H'FFFE4	ADDRCH	8	AD9	AD8	AD7	AD6	AD5	AD4	AD3	AD2	
H'FFFE5	ADDRCL	8	AD1	AD0	—	—	—	—	—	—	
H'FFFE6	ADDRDH	8	AD9	AD8	AD7	AD6	AD5	AD4	AD3	AD2	
H'FFFE7	ADDRDL	8	AD1	AD0	—	—	—	—	—	—	
H'FFFE8	ADCSR	8	ADF	ADIE	ADST	SCAN	CKS	CH2	CH1	CH0	
H'FFFE9	ADCR	8	TRGE	—	—	—	—	—	—	—	

## B.2 Functions



**P1DDR—Port 1 Data Direction Register****H'EE000****Port 1**

	Bit	7	6	5	4	3	2	1	0
		P17DDR	P16DDR	P15DDR	P14DDR	P13DDR	P12DDR	P11DDR	P10DDR
Modes 1 to 4	Initial value	1	1	1	1	1	1	1	1
	Read/Write	—	—	—	—	—	—	—	—
Modes 5 to 7	Initial value	0	0	0	0	0	0	0	0
	Read/Write	W	W	W	W	W	W	W	W

Port 1 input/output select

0	Generic input
1	Generic output

**P2DDR—Port 2 Data Direction Register****H'EE001****Port 2**

	Bit	7	6	5	4	3	2	1	0
		P27DDR	P26DDR	P25DDR	P24DDR	P23DDR	P22DDR	P21DDR	P20DDR
Modes 1 to 4	Initial value	1	1	1	1	1	1	1	1
	Read/Write	—	—	—	—	—	—	—	—
Modes 5 to 7	Initial value	0	0	0	0	0	0	0	0
	Read/Write	W	W	W	W	W	W	W	W

Port 2 input/output select

0	Generic input
1	Generic output

**P3DDR—Port 3 Data Direction Register****H'EE002****Port 3**

Bit	7	6	5	4	3	2	1	0
	P37DDR	P36DDR	P35DDR	P34DDR	P33DDR	P32DDR	P31DDR	P30DDR
Initial value	0	0	0	0	0	0	0	0
Read/Write	W	W	W	W	W	W	W	W

Port 3 input/output select

0	Generic input
1	Generic output

**P4DDR—Port 4 Data Direction Register****H'EE003****Port 4**

Bit	7	6	5	4	3	2	1	0
	P47DDR	P46DDR	P45DDR	P44DDR	P43DDR	P42DDR	P41DDR	P40DDR
Initial value	0	0	0	0	0	0	0	0
Read/Write	W	W	W	W	W	W	W	W

Port 4 input/output select

0	Generic input
1	Generic output

**P5DDR—Port 5 Data Direction Register**
**H'EE004**
**Port 5**

Bit	7	6	5	4	3	2	1	0
	—	—	—	—	P5 <sub>3</sub> DDR	P5 <sub>2</sub> DDR	P5 <sub>1</sub> DDR	P5 <sub>0</sub> DDR
Modes 1 to 4	1	1	1	1	1	1	1	1
Modes 5 to 7	1	1	1	1	0	0	0	0
Initial value	—	—	—	—	W	W	W	W
Read/Write	—	—	—	—	—	—	—	—

Port 5 input/output select	
0	Generic input pin
1	Generic output pin

**P6DDR—Port 6 Data Direction Register**
**H'EE005**
**Port 6**

Bit	7	6	5	4	3	2	1	0
	—	P6 <sub>6</sub> DDR	P6 <sub>5</sub> DDR	P6 <sub>4</sub> DDR	P6 <sub>3</sub> DDR	P6 <sub>2</sub> DDR	P6 <sub>1</sub> DDR	P6 <sub>0</sub> DDR
Initial value	1	0	0	0	0	0	0	0
Read/Write	—	W	W	W	W	W	W	W

Port 6 input/output select	
0	Generic input
1	Generic output

Bit	7	6	5	4	3	2	1	0
	—	—	—	P84DDR	P83DDR	P82DDR	P81DDR	P80DDR
Modes 1 to 4	1	1	1	1	0	0	0	0
Read/Write	—	—	—	W	W	W	W	W
Modes 5 to 7	1	1	1	0	0	0	0	0
Read/Write	—	—	—	W	W	W	W	W

Port 8 input/output select

0	Generic input
1	Generic output

**P9DDR—Port 9 Data Direction Register****H'EE008****Port 9**

Bit	7	6	5	4	3	2	1	0
	—	—	P95DDR	P94DDR	P93DDR	P92DDR	P91DDR	P90DDR
Initial value	1	1	0	0	0	0	0	0
Read/Write	—	—	W	W	W	W	W	W

Port 9 input/output select

0	Generic input
1	Generic output

**PADDR—Port A Data Direction Register****H'EE009****Port A**

Bit	7	6	5	4	3	2	1	0
	PA7DDR	PA6DDR	PA5DDR	PA4DDR	PA3DDR	PA2DDR	PA1DDR	PA0DDR
Modes 3, 4	Initial value	1	0	0	0	0	0	0
	Read/Write	—	W	W	W	W	W	W
Modes 1, 2, 5, 6, 7	Initial value	0	0	0	0	0	0	0
	Read/Write	W	W	W	W	W	W	W

Port A input/output select

0	Generic input
1	Generic output

**PBDDR—Port B Data Direction Register****H'EE00A****Port B**

Bit	7	6	5	4	3	2	1	0
	PB7DDR	PB6DDR	PB5DDR	PB4DDR	PB3DDR	PB2DDR	PB1DDR	PB0DDR
Initial value	0	0	0	0	0	0	0	0
Read/Write	W	W	W	W	W	W	W	W

Port B input/output select

0	Generic input
1	Generic output



Bit	7	6	5	4	3	2	1	0
	—	—	—	—	—	MDS2	MDS1	MDS0
Initial value	1	1	0	0	0	—*	—*	—*
Read/Write	—	—	—	—	—	R	R	R

Mode select 2 to 0

Bit 2	Bit 1	Bit 0	Operating Mode
MD <sub>2</sub>	MD <sub>1</sub>	MD <sub>0</sub>	
0	0	0	—
		1	Mode 1
	1	0	Mode 2
		1	Mode 3
1	0	0	Mode 4
		1	Mode 5
	1	0	Mode 6
		1	Mode 7

Note: \* Determined by the state of the mode pins (MD<sub>2</sub> to MD<sub>0</sub>).

Bit	7	6	5	4	3	2	1	0
	SSBY	STS2	STS1	STS0	UE	NMIEG	SSOE	RAME
Initial value	0	0	0	0	1	0	0	1
Read/Write	R/W	R/W	R/W	R/W	R/W	R/W	R/W	R/W

0	On-chip RAM is disabled
1	On-chip RAM is enabled

0	In software standby mode, all address bus and bus control signals are high-impedance
1	In software standby mode, address bus retains output state and bus control signals are fixed high

0	An interrupt is requested at the falling edge of NMI
1	An interrupt is requested at the rising edge of NMI

0	CCR bit 6 (UI) is used as an interrupt mask bit
1	CCR bit 6 (UI) is used as a user bit

Bit 6	Bit 5	Bit 4	Standby Timer
STS2	STS1	STS0	
0	0	0	Waiting Time = 8,192 states
		1	Waiting Time = 16,384 states
	1	0	Waiting Time = 32,768 states
		1	Waiting Time = 65,536 states
1	0	0	Waiting Time = 131,072 states
		1	Waiting Time = 26,2144 states
	1	0	Waiting Time = 1,024 states
		1	Illegal setting

0	SLEEP instruction causes transition to sleep mode
1	SLEEP instruction causes transition to software standby mode

**BRCR—Bus Release Control Register**
**H'EE013**
**Bus controller**

Bit		7	6	5	4	3	2	1	0
		A23E	A22E	A21E	A20E	—	—	—	BRLE
Modes 1, 2, 6, 7	Initial value	1	1	1	1	1	1	1	0
	Read/Write	—	—	—	—	—	—	—	R/W
Modes 3, 4	Initial value	1	1	1	0	1	1	1	0
	Read/Write	R/W	R/W	R/W	—	—	—	—	R/W
Mode 5	Initial value	1	1	1	1	1	1	1	0
	Read/Write	R/W	R/W	R/W	R/W	—	—	—	R/W

Address 23 to 20 enable

0	Address output
1	Other input/output

Bus release enable

0	The bus cannot be released to an external device
1	The bus can be released to an external device

**ISCR—IRQ Sense Control Register**
**H'EE014**
**Interrupt Controller**

Bit		7	6	5	4	3	2	1	0
		—	—	IRQ5SC	IRQ4SC	IRQ3SC	IRQ2SC	IRQ1SC	IRQ0SC
Initial value		0	0	0	0	0	0	0	0
Read/Write		R/W	R/W	R/W	R/W	R/W	R/W	R/W	R/W

IRQ5 to IRQ0 sense control

0	Interrupts are requested when $\overline{IRQ}_5$ to $\overline{IRQ}_0$ are low
1	Interrupts are requested by falling-edge input at $\overline{IRQ}_5$ to $\overline{IRQ}_0$

## IER—IRQ Enable Register

H'EE015

Interrupt Controller

Bit	7	6	5	4	3	2	1	0
	—	—	IRQ5E	IRQ4E	IRQ3E	IRQ2E	IRQ1E	IRQ0E
Initial value	0	0	0	0	0	0	0	0
Read/Write	R/W	R/W	R/W	R/W	R/W	R/W	R/W	R/W

IRQ<sub>5</sub> to IRQ<sub>0</sub> enable

0	IRQ <sub>5</sub> to IRQ <sub>0</sub> interrupts are disabled
1	IRQ <sub>5</sub> to IRQ <sub>0</sub> interrupts are enabled

## ISR—IRQ Status Register

H'EE016

Interrupt Controller

Bit	7	6	5	4	3	2	1	0
	—	—	IRQ5F	IRQ4F	IRQ3F	IRQ2F	IRQ1F	IRQ0F
Initial value	0	0	0	0	0	0	0	0
Read/Write	—	—	R/(W)*	R/(W)*	R/(W)*	R/(W)*	R/(W)*	R/(W)*

IRQ<sub>5</sub> to IRQ<sub>0</sub> flags

Bits 5 to 0	Setting and Clearing Conditions
IRQ <sub>5F</sub> to IRQ <sub>0F</sub>	
0	[Clearing conditions] <ul style="list-style-type: none"> <li>• Read IRQ<sub>nF</sub> when IRQ<sub>nF</sub> = 1, then write 0 in IRQ<sub>nF</sub>.</li> <li>• IRQ<sub>nSC</sub> = 0, <math>\overline{\text{IRQn}}</math> input is high, and interrupt exception handling is being carried out.</li> <li>• IRQ<sub>nSC</sub> = 1 and IRQ<sub>n</sub> interrupt exception handling is being carried out.</li> </ul>
1	[Setting conditions] <ul style="list-style-type: none"> <li>• IRQ<sub>nSC</sub> = 0 and <math>\overline{\text{IRQn}}</math> input is low.</li> <li>• IRQ<sub>nSC</sub> = 1 and <math>\overline{\text{IRQn}}</math> input changes from high to low.</li> </ul>

(n = 5 to 0)

Note: \* Only 0 can be written, to clear the flag.

## IPRA—Interrupt Priority Register A

H'EE018

Interrupt Controller

Bit	7	6	5	4	3	2	1	0
	IPRA7	IPRA6	IPRA5	IPRA4	IPRA3	IPRA2	IPRA1	IPRA0
Initial value	0	0	0	0	0	0	0	0
Read/Write	R/W	R/W	R/W	R/W	R/W	R/W	R/W	R/W

Priority level A7 to A0

0	Priority level 0 (low priority)
1	Priority level 1 (high priority)

- Interrupt sources controlled by each bit

IPRA	Bit	Bit 7	Bit 6	Bit 5	Bit 4	Bit 3	Bit 2	Bit 1	Bit 0
		IPRA7	IPRA6	IPRA5	IPRA4	IPRA3	IPRA2	IPRA1	IPRA0
	Interrupt source	IRQ0	IRQ1	IRQ2, IRQ3	IRQ4, IRQ5	WDT, DRAM interface, A/D converter	16-bit timer channel 0	16-bit timer channel 1	16-bit timer channel 2

## IPRB—Interrupt Priority Register B

H'EE019

Interrupt Controller

Bit	7	6	5	4	3	2	1	0
	IPRB7	IPRB6	IPRB5	—	IPRB3	IPRB2	IPRB1	—
Initial value	0	0	0	0	0	0	0	0
Read/Write	R/W	R/W	R/W	R/W	R/W	R/W	R/W	R/W

Priority level B7 to B5, B3 to B1

0	Priority level 0 (low priority)
1	Priority level 1 (high priority)

- Interrupt sources controlled by each bit

IPRB	Bit	Bit 7	Bit 6	Bit 5	Bit 4	Bit 3	Bit 2	Bit 1	Bit 0
		IPRB7	IPRB6	IPRB5	—	IPRB3	IPRB2	IPRB1	—
	Interrupt source	8-bit timer channels 0 and 1	8-bit timer channels 2 and 3	DMAC	—	SCI channel 0	SCI channel 1	SCI channel 2	—

Bit	7	6	5	4	3	2	1	0
	—	—	—	—	—	—	—	DASTE
Initial value	1	1	1	1	1	1	1	0
Read/Write	—	—	—	—	—	—	—	R/W

D/A standby enable

0	D/A output is disabled in software standby mode (Initial value)
1	D/A output is enabled in software standby mode

Bit	7	6	5	4	3	2	1	0
	—	—	—	—	—	—	DIV1	DIV0
Initial value	1	1	1	1	1	1	0	0
Read/Write	—	—	—	—	—	—	R/W	R/W

Divide 1 and 0

Bit 1	Bit 0	Frequency Division Ratio
DIV1	DIV0	
0	0	1/1 (Initial value)
	1	1/2
1	0	1/4
	1	1/8

MSTCRH—Module Standby Control Register H					H'EE01C		System control	
Bit	7	6	5	4	3	2	1	0
	PSTOP	—	—	—	—	MSTPH2	MSTPH1	MSTPH0
Initial value	0	1	1	1	1	0	0	0
Read/Write	R/W	—	—	—	—	R/W	R/W	R/W
	Reserved bits			Module standby H2 to H0 Selection bits for placing modules in standby state.				
	<p><math>\phi</math> clock stop Enables or disables <math>\emptyset</math> clock output.</p>							

MSTCRL—Module Standby Control Register L					H'EE01D		System control	
Bit	7	6	5	4	3	2	1	0
	MSTPL7	—	MSTPL5	MSTPL4	MSTPL3	MSTPL2	—	MSTPL0
Initial value	0	0	0	0	0	0	0	0
Read/Write	R/W	R/W	R/W	R/W	R/W	R/W	R/W	R/W
	Reserved bits		Module standby L7, L5 to L2, L0 Selection bits for placing modules in standby state.					



**ADRCR—Address Control Register****H'EE01E****Bus controller**

Bit	7	6	5	4	3	2	1	0
	—	—	—	—	—	—	—	ADRCTL
Initial value	1	1	1	1	1	1	1	1
Read/Write	—	—	—	—	—	—	—	R/W

Reserved bits
Address control

Selects address update mode 1 or address update mode 2.

ADRCTL	Description
0	Address update mode 2 is selected
1	Address update mode 1 is selected (Initial value)

Note: \* This register is used only in the flash memory R version and mask ROM version.

**CSCR—Chip Select Control Register****H'EE01F****Bus controller**

Bit	7	6	5	4	3	2	1	0
	CS7E	CS6E	CS5E	CS4E	—	—	—	—
Initial value	0	0	0	0	1	1	1	1
Read/Write	R/W	R/W	R/W	R/W	—	—	—	—

Chip select 7 to 4 enable

Bit n	Description
CSnE	
0	Output of chip select signal CSn is disabled (Initial value)
1	Output of chip select signal CSn is enabled

(n = 7 to 4)

**ABWCR—Bus Width Control Register****H'EE020****Bus controller**

Bit	7	6	5	4	3	2	1	0
	ABW7	ABW6	ABW5	ABW4	ABW3	ABW2	ABW1	ABW0
Modes 1, 3, 5, 6, 7	Initial value	1	1	1	1	1	1	1
Modes 2, 4	Initial value	0	0	0	0	0	0	0
	Read/Write	R/W	R/W	R/W	R/W	R/W	R/W	R/W

Area 7 to 0 bus width control

Bits 7 to 0	Bus Width of Access Area	
ABW7 to ABW0		
0		Areas 7 to 0 are 16-bit access areas
1		Areas 7 to 0 are 8-bit access areas

**ASTCR—Access State Control Register****H'EE021****Bus controller**

Bit	7	6	5	4	3	2	1	0
	AST7	AST6	AST5	AST4	AST3	AST2	AST1	AST0
Initial value	1	1	1	1	1	1	1	1
Read/Write	R/W	R/W	R/W	R/W	R/W	R/W	R/W	R/W

Area 7 to 0 access state control

Bits 7 to 0	Number of States in Access Area	
AST7 to AST0		
0		Areas 7 to 0 are two-state access areas
1		Areas 7 to 0 are three-state access areas

Bit	7	6	5	4	3	2	1	0
	W71	W70	W61	W60	W51	W50	W41	W40
Initial value	1	1	1	1	1	1	1	1
Read/Write	R/W	R/W	R/W	R/W	R/W	R/W	R/W	R/W

Area 4 wait control 1 and 0

0	0	No program wait is inserted
	1	1 program wait state is inserted
1	0	2 program wait states are inserted
	1	3 program wait states are inserted

Area 5 wait control 1 and 0

0	0	No program wait is inserted
	1	1 program wait state is inserted
1	0	2 program wait states are inserted
	1	3 program wait states are inserted

Area 6 wait control 1 and 0

0	0	No program wait is inserted
	1	1 program wait state is inserted
1	0	2 program wait states are inserted
	1	3 program wait states are inserted

Area 7 wait control 1 and 0

0	0	No program wait is inserted
	1	1 program wait state is inserted
1	0	2 program wait states are inserted
	1	3 program wait states are inserted

Bit	7	6	5	4	3	2	1	0
	W31	W30	W21	W20	W11	W10	W01	W00
Initial value	1	1	1	1	1	1	1	1
Read/Write	R/W	R/W	R/W	R/W	R/W	R/W	R/W	R/W

Area 0 wait control 1 and 0

0	0	No program wait is inserted
	1	1 program wait state is inserted
1	0	2 program wait states are inserted
	1	3 program wait states are inserted

Area 1 wait control 1 and 0

0	0	No program wait is inserted
	1	1 program wait state is inserted
1	0	2 program wait states are inserted
	1	3 program wait states are inserted

Area 2 wait control 1 and 0

0	0	No program wait is inserted
	1	1 program wait state is inserted
1	0	2 program wait states are inserted
	1	3 program wait states are inserted

Area 3 wait control 1 and 0

0	0	No program wait is inserted
	1	1 program wait state is inserted
1	0	2 program wait states are inserted
	1	3 program wait states are inserted

Bit	7	6	5	4	3	2	1	0
	ICIS1	ICIS0	BROME	BRSTS1	BRSTS0	—	RDEA	WAITE
Initial value	1	1	0	0	0	1	1	0
Read/Write	R/W	R/W	R/W	R/W	R/W	—	R/W	R/W

Wait pin enable	
0	WAIT pin wait input is disabled
1	WAIT pin wait input is enabled

Area division unit select	
0	Area divisions are as follows: Area 0: 2 MB    Area 4: 1.93 MB Area 1: 2 MB    Area 5: 4 kB Area 2: 8 MB    Area 6: 23.75 kB Area 3: 2 MB    Area 7: 22 B
1	Areas 0 to 7 are the same size (2 MB)

Burst cycle select 0	
0	Max. 4 words in burst access
1	Max. 8 words in burst access

Burst cycle select 1	
0	Burst access cycle comprises 2 states
1	Burst access cycle comprises 3 states

Burst ROM enable	
0	Area 0 is a basic bus interface area
1	Area 0 is a burst ROM interface area

Idle cycle insertion 0	
0	No idle cycle is inserted in case of consecutive external read and write cycles
1	Idle cycle is inserted in case of consecutive external read and write cycles

Idle cycle insertion 1	
0	No idle cycle is inserted in case of consecutive external read cycles for different areas
1	Idle cycle is inserted in case of consecutive external read cycles for different areas

Bit	7	6	5	4	3	2	1	0
	DRAS2	DRAS1	DRAS0	—	BE	RDM	SRFMD	RFSHE
Initial value	0	0	0	1	0	0	0	0
Read/Write	R/W	R/W	R/W	—	R/W	R/W	R/W	R/W

## Refresh pin enable

0	RFSH pin refresh signal output is disabled
1	RFSH pin refresh signal output is enabled

## Self-refresh mode

0	DRAM self-refreshing is disabled in software standby mode
1	DRAM self-refreshing is enabled in software standby mode

## RAS down mode

0	DRAM interface: RAS up mode selected
1	DRAM interface: RAS down mode selected

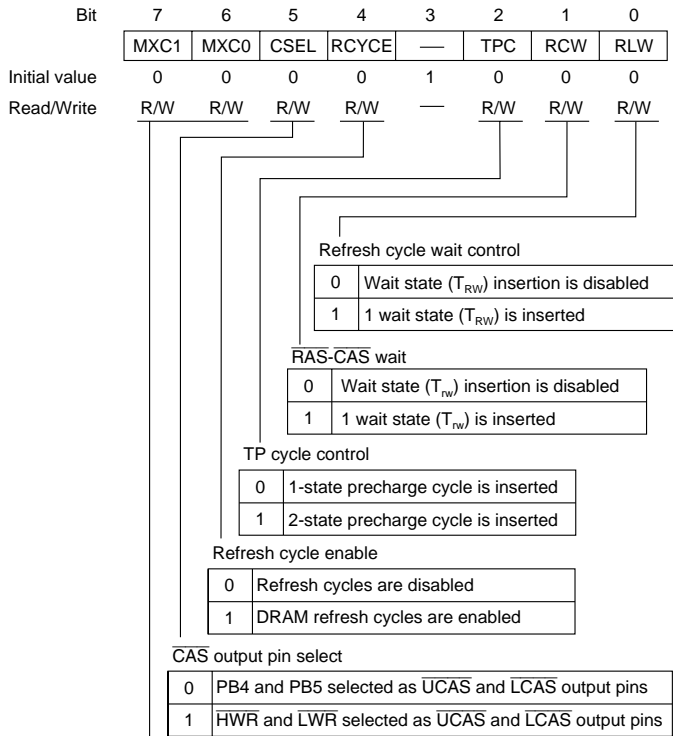
## Burst access enable

0	Burst disabled (always full access)
1	DRAM space access performed in fast page mode

## DRAM area select

DRAS2	DRAS1	DRAS0	Area 5	Area 4	Area 3	Area 2
0	0	0	Normal	Normal	Normal	Normal
		1	Normal	Normal	Normal	DRAM space ( $\overline{CS}_2$ )
	1	0	Normal	Normal	DRAM space ( $\overline{CS}_3$ )	DRAM space ( $\overline{CS}_2$ )
		1	Normal	Normal	DRAM space ( $\overline{CS}_2$ )*	
1	0	0	Normal	DRAM space ( $\overline{CS}_4$ )	DRAM space ( $\overline{CS}_3$ )	DRAM space ( $\overline{CS}_2$ )
		1	DRAM space ( $\overline{CS}_5$ )	DRAM space ( $\overline{CS}_4$ )	DRAM space ( $\overline{CS}_3$ )	DRAM space ( $\overline{CS}_2$ )
	1	0	DRAM space ( $\overline{CS}_4$ )*		DRAM space ( $\overline{CS}_2$ )*	
		1	DRAM space ( $\overline{CS}_2$ )*			

Note: A single  $\overline{CS}_n$  pin serves as a common  $\overline{RAS}$  output pin for a number of areas. Unused  $\overline{CS}_n$  pins can be used as input/output ports.



Multiplex control 1 and 0

MXC1	MXC0	Description												
0	0	Column address: 8 bits Compared address: <table style="width: 100%; border-collapse: collapse;"> <tr> <td style="padding-left: 20px;">Modes 1, 2</td> <td style="padding-left: 20px;">8-bit access space</td> <td style="text-align: right;">A<sub>19</sub> to A<sub>8</sub></td> </tr> <tr> <td></td> <td style="padding-left: 20px;">16-bit access space</td> <td style="text-align: right;">A<sub>19</sub> to A<sub>9</sub></td> </tr> <tr> <td style="padding-left: 20px;">Modes 3, 4, 5</td> <td style="padding-left: 20px;">8-bit access space</td> <td style="text-align: right;">A<sub>23</sub> to A<sub>8</sub></td> </tr> <tr> <td></td> <td style="padding-left: 20px;">16-bit access space</td> <td style="text-align: right;">A<sub>23</sub> to A<sub>9</sub></td> </tr> </table>	Modes 1, 2	8-bit access space	A <sub>19</sub> to A <sub>8</sub>		16-bit access space	A <sub>19</sub> to A <sub>9</sub>	Modes 3, 4, 5	8-bit access space	A <sub>23</sub> to A <sub>8</sub>		16-bit access space	A <sub>23</sub> to A <sub>9</sub>
	Modes 1, 2	8-bit access space	A <sub>19</sub> to A <sub>8</sub>											
	16-bit access space	A <sub>19</sub> to A <sub>9</sub>												
Modes 3, 4, 5	8-bit access space	A <sub>23</sub> to A <sub>8</sub>												
	16-bit access space	A <sub>23</sub> to A <sub>9</sub>												
1	Column address: 9 bits Compared address: <table style="width: 100%; border-collapse: collapse;"> <tr> <td style="padding-left: 20px;">Modes 1, 2</td> <td style="padding-left: 20px;">8-bit access space</td> <td style="text-align: right;">A<sub>19</sub> to A<sub>9</sub></td> </tr> <tr> <td></td> <td style="padding-left: 20px;">16-bit access space</td> <td style="text-align: right;">A<sub>19</sub> to A<sub>10</sub></td> </tr> <tr> <td style="padding-left: 20px;">Modes 3, 4, 5</td> <td style="padding-left: 20px;">8-bit access space</td> <td style="text-align: right;">A<sub>23</sub> to A<sub>9</sub></td> </tr> <tr> <td></td> <td style="padding-left: 20px;">16-bit access space</td> <td style="text-align: right;">A<sub>23</sub> to A<sub>10</sub></td> </tr> </table>	Modes 1, 2	8-bit access space	A <sub>19</sub> to A <sub>9</sub>		16-bit access space	A <sub>19</sub> to A <sub>10</sub>	Modes 3, 4, 5	8-bit access space	A <sub>23</sub> to A <sub>9</sub>		16-bit access space	A <sub>23</sub> to A <sub>10</sub>	
Modes 1, 2	8-bit access space	A <sub>19</sub> to A <sub>9</sub>												
	16-bit access space	A <sub>19</sub> to A <sub>10</sub>												
Modes 3, 4, 5	8-bit access space	A <sub>23</sub> to A <sub>9</sub>												
	16-bit access space	A <sub>23</sub> to A <sub>10</sub>												
1	0	Column address: 10 bits Compared address: <table style="width: 100%; border-collapse: collapse;"> <tr> <td style="padding-left: 20px;">Modes 1, 2</td> <td style="padding-left: 20px;">8-bit access space</td> <td style="text-align: right;">A<sub>19</sub> to A<sub>10</sub></td> </tr> <tr> <td></td> <td style="padding-left: 20px;">16-bit access space</td> <td style="text-align: right;">A<sub>19</sub> to A<sub>11</sub></td> </tr> <tr> <td style="padding-left: 20px;">Modes 3, 4, 5</td> <td style="padding-left: 20px;">8-bit access space</td> <td style="text-align: right;">A<sub>23</sub> to A<sub>10</sub></td> </tr> <tr> <td></td> <td style="padding-left: 20px;">16-bit access space</td> <td style="text-align: right;">A<sub>23</sub> to A<sub>11</sub></td> </tr> </table>	Modes 1, 2	8-bit access space	A <sub>19</sub> to A <sub>10</sub>		16-bit access space	A <sub>19</sub> to A <sub>11</sub>	Modes 3, 4, 5	8-bit access space	A <sub>23</sub> to A <sub>10</sub>		16-bit access space	A <sub>23</sub> to A <sub>11</sub>
	Modes 1, 2	8-bit access space	A <sub>19</sub> to A <sub>10</sub>											
	16-bit access space	A <sub>19</sub> to A <sub>11</sub>												
Modes 3, 4, 5	8-bit access space	A <sub>23</sub> to A <sub>10</sub>												
	16-bit access space	A <sub>23</sub> to A <sub>11</sub>												
1	Illegal setting													

Bit	7	6	5	4	3	2	1	0
	CMF	CMIE	CKS2	CKS1	CKS0	—	—	—
Initial value	0	0	0	0	0	1	1	1
Read/Write	R/(W)*	R/W	R/W	R/W	R/W	—	—	—

## Refresh counter clock select

CKS2	CKS1	CKS0	Description
0	0	0	Count operation halted
		1	$\phi/2$ used as counter clock
	1	0	$\phi/8$ used as counter clock
		1	$\phi/32$ used as counter clock
1	0	0	$\phi/128$ used as counter clock
		1	$\phi/512$ used as counter clock
	1	0	$\phi/2048$ used as counter clock
		1	$\phi/4096$ used as counter clock

## Compare match interrupt enable

0	The CMI interrupt requested by the CMF flag is disabled
1	The CMI interrupt requested by the CMF flag is enabled

## Compare match flag

0	[Clearing conditions] <ul style="list-style-type: none"> <li>• Cleared by a reset and in standby mode</li> <li>• Cleared by reading CMF when CMF = 1, then writing 0 in CMF</li> </ul>
1	[Setting condition] When RTCNT = RTCOR

Note: Only 0 can be written to clear the flag.



**RTCNT—Refresh Timer Counter****H'EE029****DRAM interface**

Bit	7	6	5	4	3	2	1	0
Initial value	0	0	0	0	0	0	0	0
Read/Write	R/W	R/W	R/W	R/W	R/W	R/W	R/W	R/W

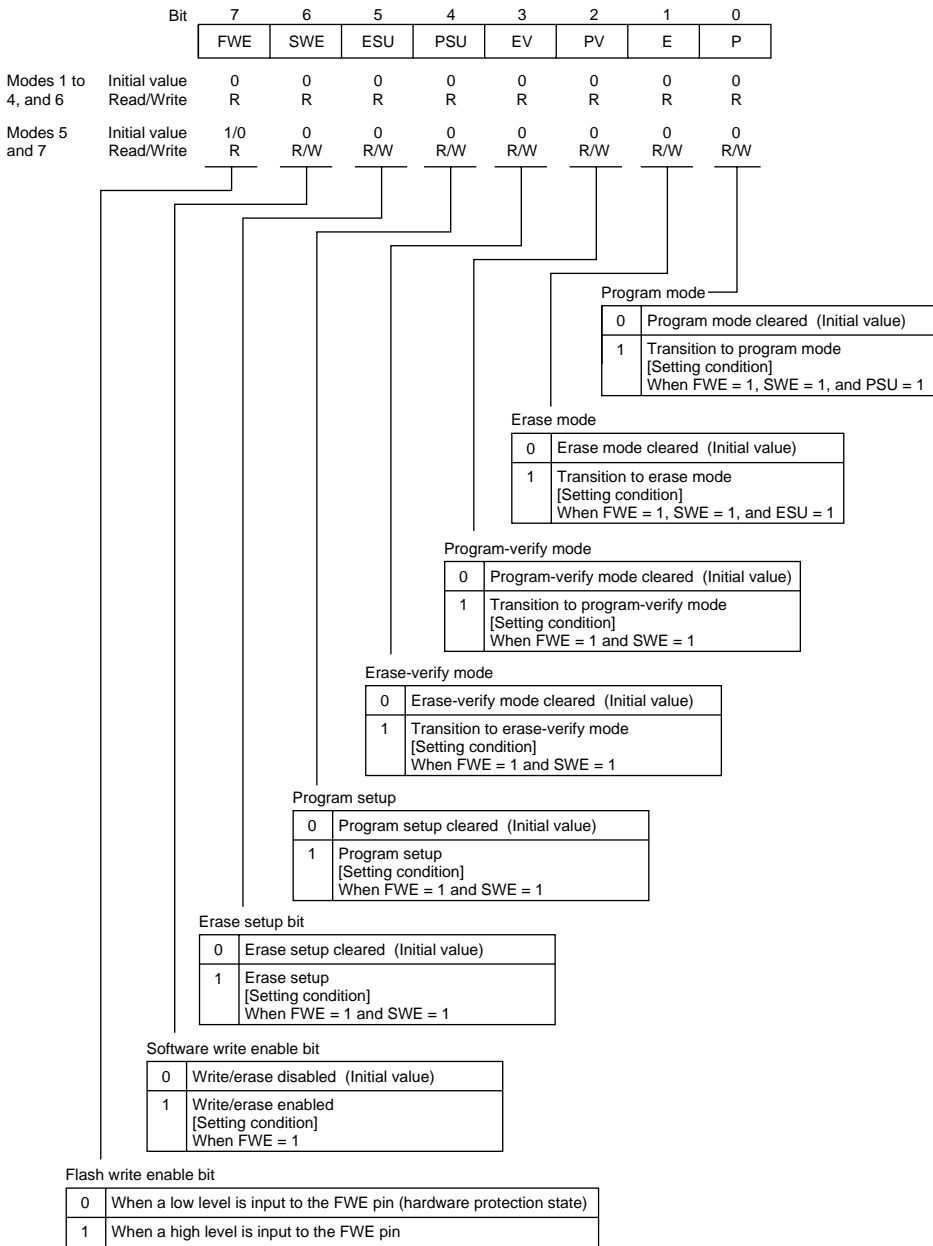
Incremented by internal clock selected  
by bits CKS2 to CKS0 in RTMCSR

**RTCOR—Refresh Time Constant Register****H'EE02A****DRAM interface**

Bit	7	6	5	4	3	2	1	0
Initial value	1	1	1	1	1	1	1	1
Read/Write	R/W	R/W	R/W	R/W	R/W	R/W	R/W	R/W

RTCNT compare match period

Note: Only byte access can be used on this register.



Note: This register is used only in the flash memory and flash memory R versions. Reading the corresponding address in a mask ROM version will always return 1s, and writes to this address are disabled. Fix the FWE pin low in mode 6.

Bit		7	6	5	4	3	2	1	0
EBR		EB7	EB6	EB5	EB4	EB3	EB2	EB1	EB0
Modes 1 to 4, and 6	Initial value	0	0	0	0	0	0	0	0
	Read/Write	R	R	R	R	R	R	R	R
Modes 5 and 7	Initial value	0	0	0	0	0	0	0	0
	Read/Write	R/W	R/W	R/W	R/W	R/W	R/W	R/W	R/W

Block 7 to 0

0	Block EB7 to EB0 is not selected (Initial value)
1	Block EB7 to EB0 is selected

Note: When not erasing flash memory, EBR should be cleared to H'00.

Note: This register is used only in the flash memory and flash memory R versions. Reading the corresponding address in a mask ROM version will always return 1s, and writes to this address are disabled.

Bit	7	6	5	4	3	2	1	0
	P27PCR	P26PCR	P25PCR	P24PCR	P23PCR	P22PCR	P21PCR	P20PCR
Initial value	0	0	0	0	0	0	0	0
Read/Write	R/W	R/W	R/W	R/W	R/W	R/W	R/W	R/W

Port 2 input pull-up control 7 to 0

0	Input pull-up transistor is off
1	Input pull-up transistor is on

Note: Valid when the corresponding P2DDR bit is cleared to 0 (designating generic input).

**P4PCR—Port 4 Input Pull-Up Control Register****H'EE03E****Port 4**

Bit	7	6	5	4	3	2	1	0
	P47PCR	P46PCR	P45PCR	P44PCR	P43PCR	P42PCR	P41PCR	P40PCR
Initial value	0	0	0	0	0	0	0	0
Read/Write	R/W	R/W	R/W	R/W	R/W	R/W	R/W	R/W

Port 4 input pull-up control 7 to 0

0	Input pull-up transistor is off
1	Input pull-up transistor is on

Note: Valid when the corresponding P4DDR bit is cleared to 0 (designating generic input).

**P5PCR—Port 5 Input Pull-Up Control Register****H'EE03F****Port 5**

Bit	7	6	5	4	3	2	1	0
	—	—	—	—	P53PCR	P52PCR	P51PCR	P50PCR
Initial value	1	1	1	1	0	0	0	0
Read/Write	—	—	—	—	R/W	R/W	R/W	R/W

Port 5 input pull-up control 3 to 0

0	Input pull-up transistor is off
1	Input pull-up transistor is on

Note: Valid when the corresponding P5DDR bit is cleared to 0 (designating generic input).

RAM Control Register		RAMCR			H'EE077		Flash Memory		
	Bit	7	6	5	4	3	2	1	0
		—	—	—	—	RAMS	RAM2	RAM1	—
Modes 1 to 4	Initial value	1	1	1	1	0	0	0	1
	R/W	—	—	—	—	R	R	R	—
Modes 5 to 7	Initial value	1	1	1	1	0	0	0	1
	R/W	—	—	—	—	R/W*	R/W*	R/W*	—
<b>Reserved bits</b>									
RAM select, RAM2, RAM1									
	Bit 3	Bit 2	Bit 1	RAM Area			RAM Emulation Status		
	RAMS	RAM2	RAM1						
	0	0/1	0/1	H'FFF000 to H'FFF3FF			No emulation		
	1	0	0	H'000000 to H'0003FF			Mapping RAM		
			1	H'000400 to H'0007FF					
		1	0	H'000800 to H'000BFF					
			1	H'000C00 to H'000FFF					
<p>Note: * In mode 6 (single-chip normal mode), flash memory emulation by RAM is not supported; these bits can be modified, but must not be set to 1.</p>									
<p>Note: This register is used only in the flash memory and flash memory R versions. Reading the corresponding address in a mask ROM version will always return 1s, and writes to this address are disabled.</p>									

Bit	7	6	5	4	3	2	1	0
	FLER	—	—	—	—	—	—	—
Initial value	0	1	1	1	1	1	1	1
R/W	R	—	—	—	—	—	—	—

Reserved bits

RAM select, RAM2, RAM1

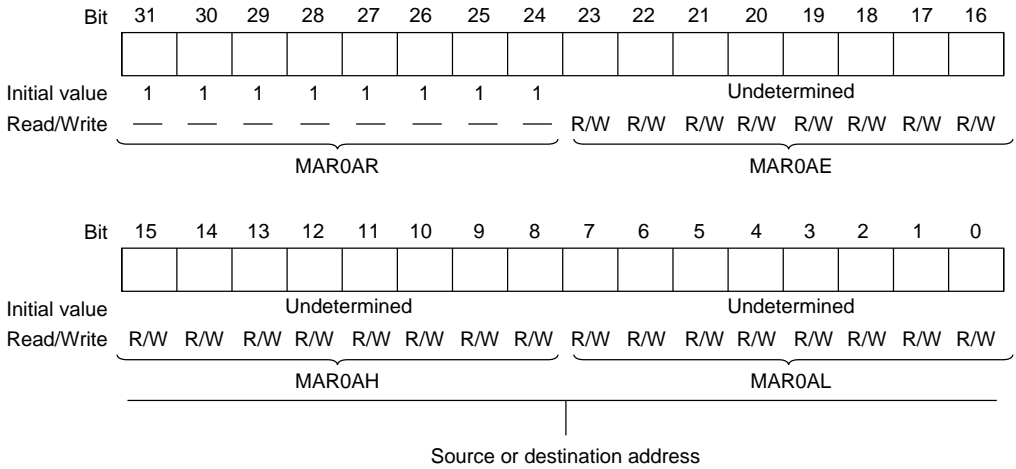
Bit 7	Description
FLER	
0	Flash memory program/erase protection (error protection) is disabled (Initial value) [Clearing condition] WDT reset, reset via the $\overline{RES}$ pin or hardware standby mode
1	An error has occurred during flash memory programming/erasing, and error protection*1 is enabled [Setting conditions] <ol style="list-style-type: none"> <li>Flash memory was read*2 while being programmed or erased (including vector or instruction fetch, but not including reading of a RAM area overlapped onto flash memory).</li> <li>A hardware exception-handling sequence (other than a reset, invalid instruction, trap instruction, or zero-divide exception) was executed just before programming or erasing.*3</li> <li>The SLEEP instruction (including software standby mode) was executed during programming or erasing.</li> </ol>

Notes 1. See 18.6.3, Error Protection, for details.

2. The read value in this case is undefined.

3. Before stack and vector read by exception handling.

Note: This register is used only in the flash memory and flash memory R versions. Reading the corresponding address in a mask ROM version will always return 1s, and writes to this address are disabled.







Bit	7	6	5	4	3	2	1	0
Initial value				Undetermined				
Read/Write	R/W	R/W	R/W	R/W	R/W	R/W	R/W	R/W

Short address mode : source or destination address

Full address mode : not used

• Short address mode

Bit	7	6	5	4	3	2	1	0
	DTE	DTSZ	DTID	RPE	DTIE	DTS2	DTS1	DTS0
Initial value	0	0	0	0	0	0	0	0
Read/Write	R/W	R/W	R/W	R/W	R/W	R/W	R/W	R/W

Data transfer select

Bit 2	Bit 1	Bit 0	Data Transfer Activation Source
DTS2	DTS1	DTS0	
0	0	0	Compare match/input capture A interrupt from 16-bit timer channel 0
		1	Compare match/input capture A interrupt from 16-bit timer channel 1
	1	0	Compare match/input capture A interrupt from 16-bit timer channel 2
		1	A/D converter conversion end interrupt
1	0	0	SCI0 transmit-data-empty interrupt
		1	SCI0 receive-data-full interrupt
	1	0	Transfer in full address mode
		1	Transfer in full address mode

Data transfer interrupt enable

0	Interrupt requested by DTE bit is disabled
1	Interrupt requested by DTE bit is enabled

Repeat enable

RPE	DTIE	Description
0	0	I/O mode
	1	
1	0	Repeat mode
	1	Idle mode

Data transfer increment/decrement

0	Incremented: If DTSZ = 0, MAR is incremented by 1 after each transfer If DTSZ = 1, MAR is incremented by 2 after each transfer
1	Decrement: If DTSZ = 0, MAR is decremented by 1 after each transfer If DTSZ = 1, MAR is decremented by 2 after each transfer

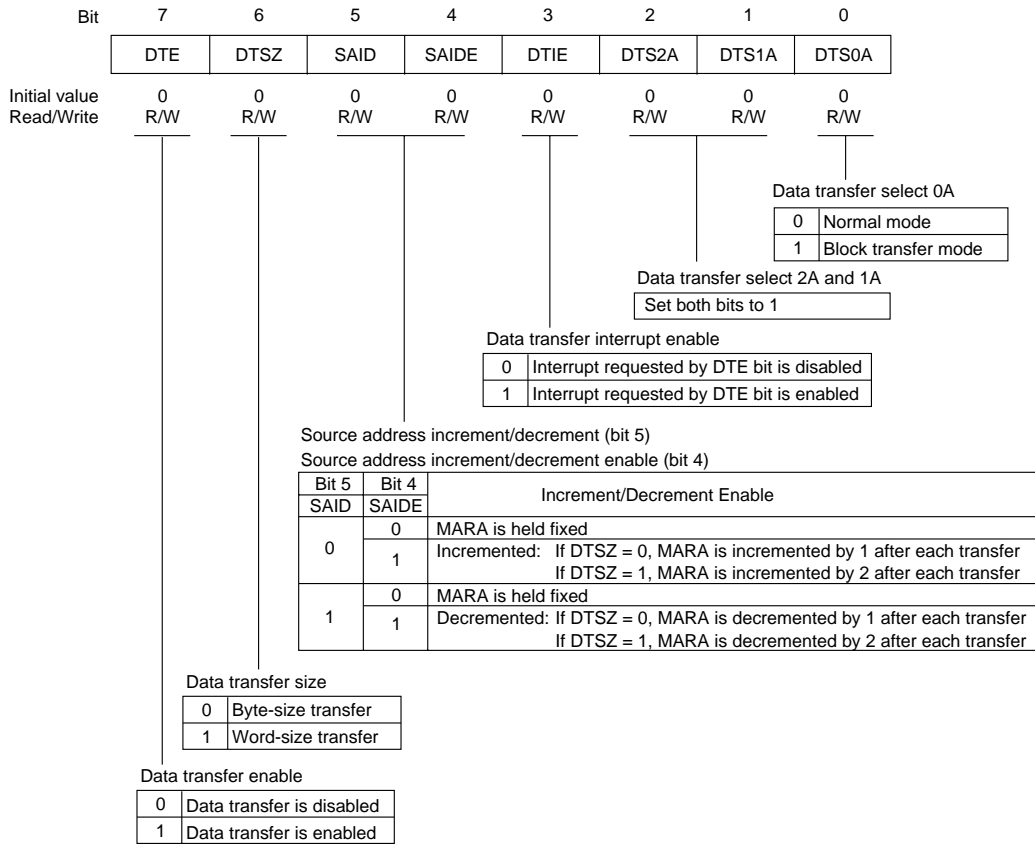
Data transfer size

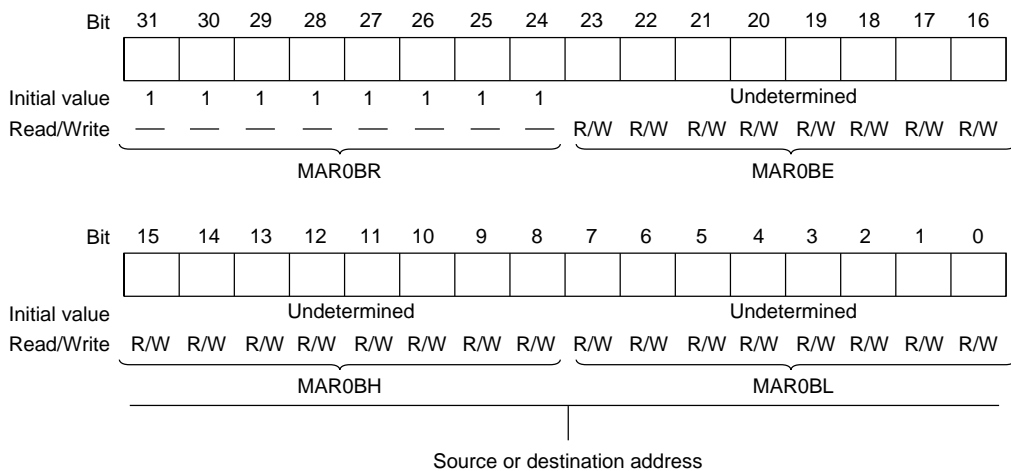
0	Byte-size transfer
1	Word-size transfer

Data transfer enable

0	Data transfer is disabled
1	Data transfer is enabled

• Full address mode







Bit	7	6	5	4	3	2	1	0
Initial value								
Read/Write	R/W	R/W	R/W	R/W	R/W	R/W	R/W	R/W

Undetermined

Short address mode : source or destination address

Full address mode : not used

• Short address mode

Bit	7	6	5	4	3	2	1	0
	DTE	DTSZ	DTID	RPE	DTIE	DTS2	DTS1	DTS0
Initial value	0	0	0	0	0	0	0	0
Read/Write	R/W	R/W	R/W	R/W	R/W	R/W	R/W	R/W

Data transfer select

Bit 2	Bit 1	Bit 0	Data Transfer Activation Source
DTS2	DTS1	DTS0	
0	0	0	Compare match/input capture A interrupt from 16-bit timer channel 0
		1	Compare match/input capture A interrupt from 16-bit timer channel 1
	1	0	Compare match/input capture A interrupt from 16-bit timer channel 2
		1	A/D converter conversion end interrupt
1	0	0	SCI0 transmit-data-empty interrupt
		1	SCI0 receive-data-full interrupt
	1	0	Falling edge of DREQ input
		1	Low level of DREQ input

Data transfer interrupt enable

0	Interrupt requested by DTE bit is disabled
1	Interrupt requested by DTE bit is enabled

Repeat enable

RPE	DTIE	Description
0	0	I/O mode
	1	
1	0	Repeat mode
	1	Idle mode

Data transfer increment/decrement

0	Incremented: If DTSZ = 0, MAR is incremented by 1 after each transfer If DTSZ = 1, MAR is incremented by 2 after each transfer
1	Decrement: If DTSZ = 0, MAR is decremented by 1 after each transfer If DTSZ = 1, MAR is decremented by 2 after each transfer

Data transfer size

0	Byte-size transfer
1	Word-size transfer

Data transfer enable

0	Data transfer is disabled
1	Data transfer is enabled



- Full address mode

Bit	7	6	5	4	3	2	1	0
	DTME	—	DAID	DAIDE	TMS	DTS2B	DTS1B	DTS0B
Initial value	0	0	0	0	0	0	0	0
Read/Write	R/W	R/W	R/W	R/W	R/W	R/W	R/W	R/W

## Data transfer master enable

0	Data transfer is disabled
1	Data transfer is enabled

## Data transfer select 2B to 0B

Bit 2 DTS2B	Bit 1 DTS1B	Bit 0 DTS0B	Data Transfer Activation Source	
			Normal Mode	Block Transfer Mode
0	0	0	Auto-request (burst mode)	Compare match/input capture A interrupt from 16-bit timer channel 0
		1	Not available	Compare match/input capture A interrupt from 16-bit timer channel 1
	1	0	Auto-request (cycle-steal mode)	Compare match/input capture A interrupt from 16-bit timer channel 2
		1	Not available	A/D converter conversion end interrupt
1	0	0	Not available	Not available
		1	Not available	Not available
	1	0	Falling edge input of DREQ	Falling edge input of DREQ
		1	Low level input at DREQ	Not available

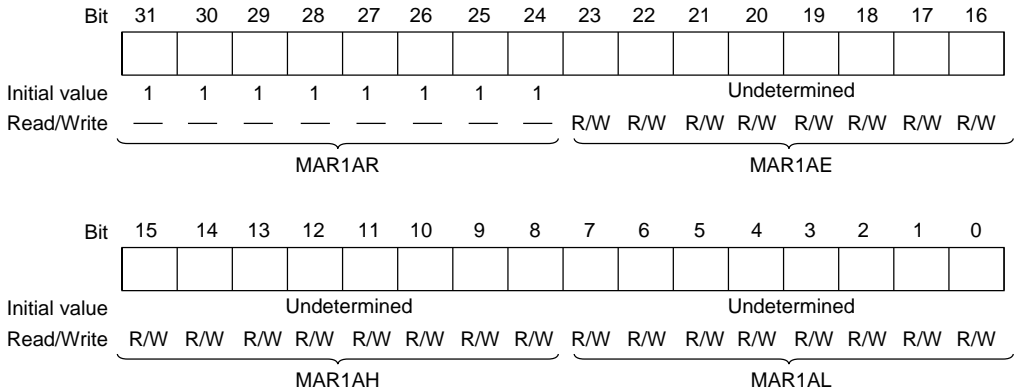
## Transfer mode select

0	Destination is the block area in block transfer mode
1	Source is the block area in block transfer mode

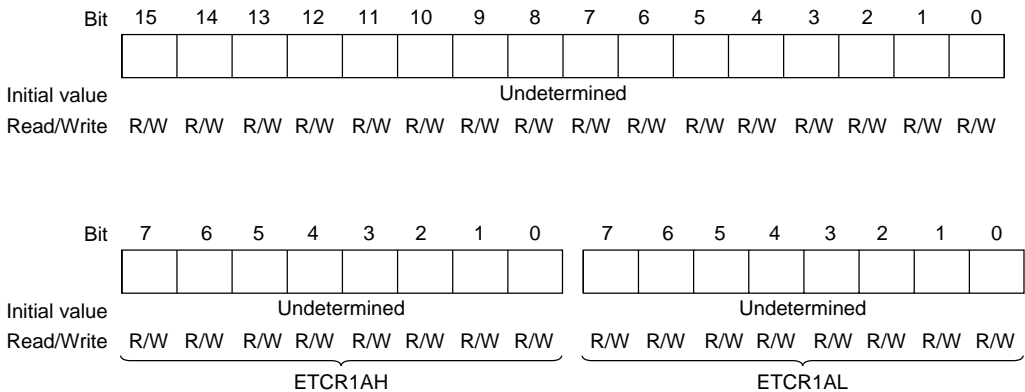
Destination address increment/decrement (bit 5)

Destination address increment/decrement enable (bit 4)

Bit 5 DAID	Bit 4 DAIDE	Increment/Decrement Enable
0	0	MARB is held fixed
	1	Incremented: If DTSZ = 0, MARB is incremented by 1 after each transfer If DTSZ = 1, MARB is incremented by 2 after each transfer
1	0	MARB is held fixed
	1	Decrement: If DTSZ = 0, MARB is decremented by 1 after each transfer If DTSZ = 1, MARB is decremented by 2 after each transfer

**MAR1A R/E/H/L—Memory Address Register 1A R/E/H/L**
**H'FFF30 H'FFF31  
H'FFF32 H'FFF33**
**DMAC1**


Note: Bit functions are the same as for DMAC0.

**ETCR1A H/L—Execute Transfer Count Register 1A H/L**
**H'FFF34 H'FFF35**
**DMAC1**


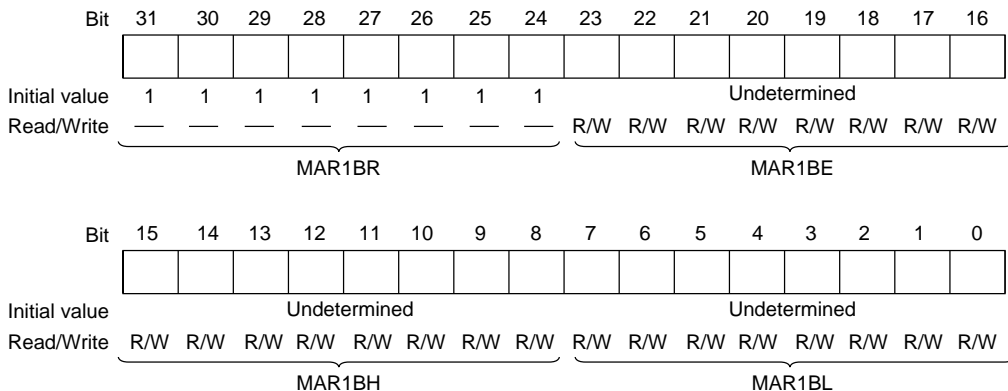
Note: Bit functions are the same as for DMAC0.

IOAR1A—I/O Address Register 1A					H'FFF36		DMAC1	
Bit	7	6	5	4	3	2	1	0
Initial value				Undetermined				
Read/Write	R/W	R/W	R/W	R/W	R/W	R/W	R/W	R/W

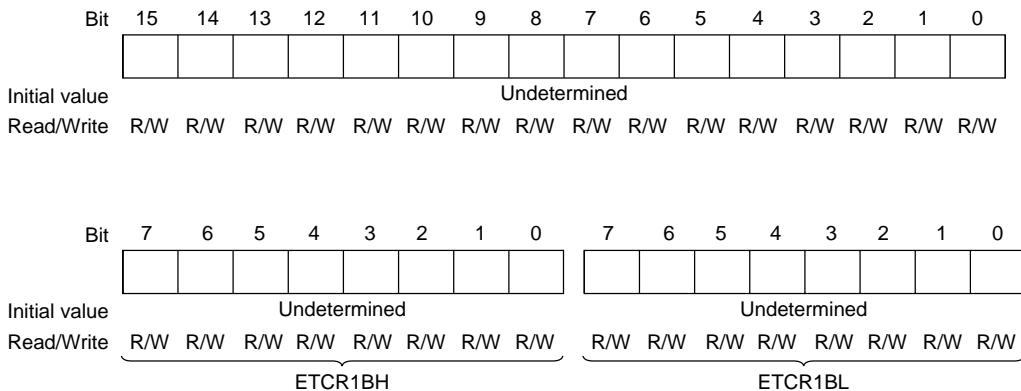
Note: Bit functions are the same as for DMAC0.

DTCR1A—Data Transfer Control Register 1A					H'FFF37		DMAC1	
• Short address mode								
Bit	7	6	5	4	3	2	1	0
	DTE	DTSZ	DTID	RPE	DTIE	DTS2	DTS1	DTS0
Initial value	0	0	0	0	0	0	0	0
Read/Write	R/W	R/W	R/W	R/W	R/W	R/W	R/W	R/W
• Full address mode								
Bit	7	6	5	4	3	2	1	0
	DTE	DTSZ	SAID	SAIDE	DTIE	DTS2A	DTS1A	DTS0A
Initial value	0	0	0	0	0	0	0	0
Read/Write	R/W	R/W	R/W	R/W	R/W	R/W	R/W	R/W

Note: Bit functions are the same as for DMAC0.

**MAR1B R/E/H/L—Memory Address Register 1B R/E/H/L**
**H'FFF38 H'FFF39  
H'FFF3A H'FFF3B**
**DMAC1**


Note: Bit functions are the same as for DMAC0.

**ETCR1B H/L—Execute Transfer Count Register 1B H/L**
**H'FFF3C H'FFF3D**
**DMAC1**


Note: Bit functions are the same as for DMAC0.

IOAR1B—I/O Address Register 1B					H'FFF3E		DMAC1	
Bit	7	6	5	4	3	2	1	0
Initial value				Undetermined				
Read/Write	R/W	R/W	R/W	R/W	R/W	R/W	R/W	R/W

Note: Bit functions are the same as for DMAC0.

DTCR1B—Data Transfer Control Register 1B					H'FFF3F		DMAC1	
• Short address mode								
Bit	7	6	5	4	3	2	1	0
	DTE	DTSZ	DTID	RPE	DTIE	DTS2	DTS1	DTS0
Initial value	0	0	0	0	0	0	0	0
Read/Write	R/W	R/W	R/W	R/W	R/W	R/W	R/W	R/W
• Full address mode								
Bit	7	6	5	4	3	2	1	0
	DTME	——	DAID	DAIDE	TMS	DTS2B	DTS1B	DTS0B
Initial value	0	0	0	0	0	0	0	0
Read/Write	R/W	R/W	R/W	R/W	R/W	R/W	R/W	R/W

Note: Bit functions are the same as for DMAC0.

Bit	7	6	5	4	3	2	1	0
	—	—	—	—	—	STR2	STR1	STR0
Initial value	1	1	1	1	1	0	0	0
Read/Write	—	—	—	—	—	R/W	R/W	R/W

Reserved bits

Counter start 0

0	TCNT0 is halted	(Initial value)
1	TCNT0 is counting	

Counter start 1

0	TCNT1 is halted	(Initial value)
1	TCNT1 is counting	

Counter start 2

0	TCNT2 is halted	(Initial value)
1	TCNT2 is counting	

Bit	7	6	5	4	3	2	1	0
	—	—	—	—	—	SYNC2	SYNC1	SYNC0
Initial value	1	1	1	1	1	0	0	0
Read/Write	—	—	—	—	—	R/W	R/W	R/W

Reserved bits

Timer synchronization 0

0	Channel 0 timer counter (TCNT0) operates independently (TCNT0 presetting/clearing is unrelated to other channels) (Initial value)
1	Channel 0 operates synchronously TCNT0 synchronous presetting/synchronous clearing is possible

Timer synchronization 1

0	Channel 1 timer counter (TCNT1) operates independently (TCNT1 presetting/clearing is unrelated to other channels) (Initial value)
1	Channel 1 operates synchronously TCNT1 synchronous presetting/synchronous clearing is possible

Timer synchronization 2

0	Channel 2 timer counter (TCNT2) operates independently (TCNT2 presetting/clearing is unrelated to other channels) (Initial value)
1	Channel 2 operates synchronously TCNT2 synchronous presetting/synchronous clearing is possible

Bit	7	6	5	4	3	2	1	0
	—	MDF	FDIR	—	—	PWM2	PWM1	PWM0
Initial value	1	0	0	1	1	0	0	0
Read/Write	—	R/W	R/W	—	—	R/W	R/W	R/W

## PWM mode 0

0	Channel 0 operates normally (Initial value)
1	Channel 0 operates in PWM mode

## PWM mode 1

0	Channel 1 operates normally (Initial value)
1	Channel 1 operates in PWM mode

## PWM mode 2

0	Channel 2 operates normally (Initial value)
1	Channel 2 operates in PWM mode

## Flag direction

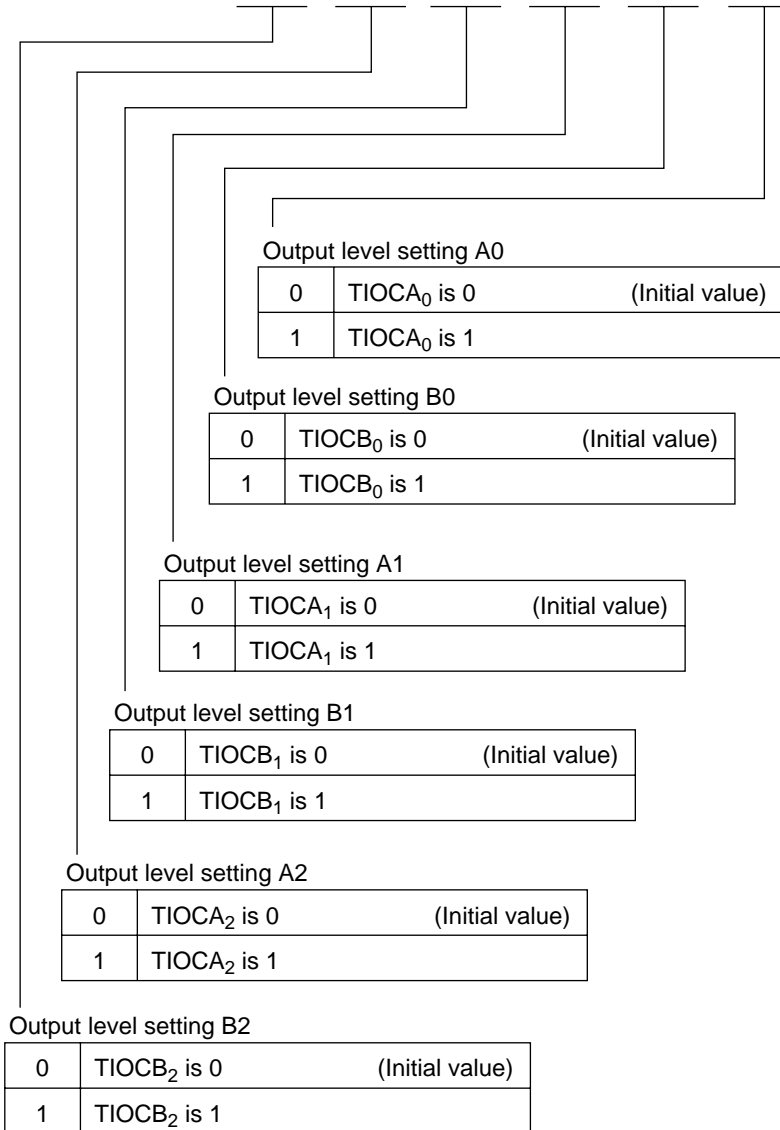
0	OVF is set to 1 in TISRC when TCNT2 overflows or underflows (Initial value)
1	OVF is set to 1 in TISRC when TCNT2 overflows

## Phase counting mode flag

0	Channel 2 operates normally (Initial value)
1	Channel 2 operates in phase counting mode



Bit	7	6	5	4	3	2	1	0
	—	—	TOB2	TOA2	TOB1	TOA1	TOB0	TOA0
Initial value	1	1	0	0	0	0	0	0
Read/Write	—	—	W	W	W	W	W	W



Bit:	7	6	5	4	3	2	1	0
	—	IMIEA2	IMIEA1	IMIEA0	—	IMFA2	IMFA1	IMFA0
Initial value:	1	0	0	0	1	0	0	0
Read/Write:	—	R/W	R/W	R/W	—	R/(W)*	R/(W)*	R/(W)*

## Input capture/compare match flag A0

0	[Clearing conditions] Read IMFA0 when IMFA0=1, then write 0 in IMFA0 DMAC activated by IMIA0 interrupt.	(Initial value)
1	[Setting conditions] TCNT0=GRA0 when GRA0 functions as an output compare register. TCNT0 value is transferred to GRA0 by an input capture signal when GRA0 functions as an input capture register.	

## Input capture/compare match flag A1

0	[Clearing conditions] Read IMFA1 when IMFA1=1, then write 0 in IMFA1 DMAC activated by IMIA1 interrupt.	(Initial value)
1	[Setting conditions] TCNT1=GRA1 when GRA1 functions as an output compare register. TCNT1 value is transferred to GRA1 by an input capture signal when GRA1 functions as an input capture register.	

## Input capture/compare match flag A2

0	[Clearing conditions] Read IMFA2 when IMFA2=1, then write 0 in IMFA2 DMAC activated by IMIA2 interrupt.	(Initial value)
1	[Setting conditions] TCNT2=GRA2 when GRA2 functions as an output compare register. TCNT2 value is transferred to GRA2 by an input capture signal when GRA2 functions as an input capture register.	

## Input capture/compare match interrupt enable A0

0	IMIA0 interrupt requested by IMFA0 flag is disabled	(Initial value)
1	IMIA0 interrupt requested by IMFA0 is enabled	

## Input capture/compare match interrupt enable A1

0	IMIA1 interrupt requested by IMFA1 flag is disabled	(Initial value)
1	IMIA1 interrupt requested by IMFA1 is enabled	

## Input capture/compare match interrupt enable A2

0	IMIA2 interrupt requested by IMFA2 flag is disabled	(Initial value)
1	IMIA2 interrupt requested by IMFA2 is enabled	

Note: \* Only 0 can be written, to clear the flag.

Bit:	7	6	5	4	3	2	1	0
	—	IMIEB2	IMIEB1	IMIEB0	—	IMFB2	IMFB1	IMFB0
Initial value:	1	0	0	0	1	0	0	0
Read/Write:	—	R/W	R/W	R/W	—	R/(W)*	R/(W)*	R/(W)*

## Input capture/compare match flag B0

0	[Clearing condition] Read IMFB0 when IMFB0=1, then write 0 in IMFB0.	(Initial value)
1	[Setting conditions] TCNT0=GRB0 when GRB0 functions as an output compare register. TCNT0 value is transferred to GRB0 by an input capture signal when GRB0 functions as an input capture register.	

## Input capture/compare match flag B1

0	[Clearing condition] Read IMFB1 when IMFB1=1, then write 0 in IMFB1.	(Initial value)
1	[Setting conditions] TCNT1=GRB1 when GRB1 functions as an output compare register. TCNT1 value is transferred to GRB1 by an input capture signal when GRB1 functions as an input capture register.	

## Input capture/compare match flag B2

0	[Clearing condition] Read IMFB2 when IMFB2=1, then write 0 in IMFB2.	(Initial value)
1	[Setting conditions] TCNT2=GRB2 when GRB2 functions as an output compare register. TCNT2 value is transferred to GRB2 by an input capture signal when GRB2 functions as an input capture register.	

## Input capture/compare match interrupt enable B0

0	IMIB0 interrupt requested by IMFB0 flag is disabled	(Initial value)
1	IMIB0 interrupt requested by IMFB0 is enabled	

## Input capture/compare match interrupt enable B1

0	IMIB1 interrupt requested by IMFB1 flag is disabled	(Initial value)
1	IMIB1 interrupt requested by IMFB1 is enabled	

## Input capture/compare match interrupt enable B2

0	IMIB2 interrupt requested by IMFB2 flag is disabled	(Initial value)
1	IMIB2 interrupt requested by IMFB2 is enabled	

Note : \* Only 0 can be written, to clear the flag.

Bit:	7	6	5	4	3	2	1	0
	—	OVIE2	OVIE1	OVIE0	—	OVF2	OVF1	OVF0
Initial value:	1	0	0	0	1	0	0	0
Read/Write:	—	R/W	R/W	R/W	—	R/(W)*	R/(W)*	R/(W)*

## Overflow flag 0

0	[Clearing condition] Read OVF0 when OVF0 = 1, then write 0 in OVF0.	(Initial value)
1	[Setting condition] TCNT0 overflowed from H'FFFF to H'0000.	

## Overflow flag 1

0	[Clearing condition] Read OVF1 when OVF1 = 1, then write 0 in OVF1.	(Initial value)
1	[Setting condition] TCNT1 overflowed from H'FFFF to H'0000.	

## Overflow flag 2

0	[Clearing condition] Read OVF2 when OVF2 = 1, then write 0 in OVF2.	(Initial value)
1	[Setting condition] TCNT2 overflowed from H'FFFF to H'0000, or underflowed from H'0000 to H'FFFF.	

## Overflow interrupt enable 0

0	OVI0 interrupt requested by OVF0 flag is disabled	(Initial value)
1	OVI0 interrupt requested by OVF0 flag is enabled	

## Overflow interrupt enable 1

0	OVI1 interrupt requested by OVF1 flag is disabled	(Initial value)
1	OVI1 interrupt requested by OVF1 flag is enabled	

## Overflow interrupt enable 2

0	OVI2 interrupt requested by OVF2 flag is disabled	(Initial value)
1	OVI2 interrupt requested by OVF2 flag is enabled	

Note : \* Only 0 can be written, to clear the flag.

Bit	7	6	5	4	3	2	1	0
	—	CCLR1	CCLR0	CKEG1	CKEG0	TPSC2	TPSC1	TPSC0
Initial value	1	0	0	0	0	0	0	0
Read/Write	—	R/W	R/W	R/W	R/W	R/W	R/W	R/W

Timer prescaler 2 to 0

Bit 2	Bit 1	Bit 0	TCNT Clock Source
TPSC2	TPSC1	TPSC0	
0	0	0	Internal clock : $\phi$ (Initial value)
		1	Internal clock : $\phi / 2$
	1	0	Internal clock : $\phi / 4$
		1	Internal clock : $\phi / 8$
1	0	0	External clock A : TCLKA input
		1	External clock B : TCLKB input
	1	0	External clock C : TCLKC input
		1	External clock D : TCLKD input

Clock edge 1 and 0

Bit 4	Bit 3	Counted Edges of External Clock
CKEG1	CKEG0	
0	0	Rising edges counted (Initial value)
0	1	Falling edges counted
1	—	Both edges counted

Counter clear 1 and 0

Bit 6	Bit 5	TCNT clear Sources
CCLR1	CCLR0	
0	0	TCNT is not cleared (Initial value)
	1	TCNT is cleared by GRA compare match or input capture
1	0	TCNT is cleared by GRB compare match or input capture
	1	Synchronous clear : TCNT is cleared in synchronization with other synchronized timers

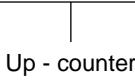
Bit:	7	6	5	4	3	2	1	0
	—	IOB2	IOB1	IOB0	—	IOA2	IOA1	IOA0
Initial value:	1	0	0	0	1	0	0	0
Read/Write:	—	R/W	R/W	R/W	—	R/W	R/W	R/W

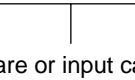
I/O control A2 to A0

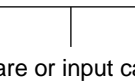
Bit 2	Bit 1	Bit 0	GRA Functions	
IOA2	IOA1	IOA0		
0	0	0	GRA is an output compare register	No output at compare match (Initial value)
		1		0 output at GRA compare match
	1	0		1 output at GRA compare match
		1		Output toggles at GRA compare match (channel 2 only: 1 output)
1	0	0	GRA is an input capture register	GRA captures rising edges of input
		1		GRA captures falling edges of input
	1	0		GRA captures both edges of input
		1		

I/O control B2 to B0

Bit 6	Bit 5	Bit 4	GRB Functions	
IOB2	IOB1	IOB0		
0	0	0	GRB is an output compare register	No output at compare match (Initial value)
		1		0 output at GRB compare match
	1	0		1 output at GRB compare match
		1		Output toggles at GRB compare match (channel 2 only: 1 output)
1	0	0	GRB is an input capture register	GRB captures rising edges of input
		1		GRB captures falling edges of input
	1	0		GRB captures both edges of input
		1		

TCNT0 H/L—Timer Counter 0 H/L							H'FFF6A, H'FFF6B			16-bit timer channel 0						
Bit	15	14	13	12	11	10	9	8	7	6	5	4	3	2	1	0
Initial value	0	0	0	0	0	0	0	0	0	0	0	0	0	0	0	0
Read/Write	R/W	R/W	R/W	R/W	R/W	R/W	R/W	R/W	R/W	R/W	R/W	R/W	R/W	R/W	R/W	R/W
 <p>Up - counter</p>																

GRA0 H/L—General Register A0 H/L							H'FFF6C, H'FFF6D			16-bit timer channel 0						
Bit	15	14	13	12	11	10	9	8	7	6	5	4	3	2	1	0
Initial value	1	1	1	1	1	1	1	1	1	1	1	1	1	1	1	1
Read/Write	R/W	R/W	R/W	R/W	R/W	R/W	R/W	R/W	R/W	R/W	R/W	R/W	R/W	R/W	R/W	R/W
 <p>Output compare or input capture register</p>																

GRB0 H/L—General Register B0 H/L							H'FFF6E, H'FFF6F			16-bit timer channel 0						
Bit	15	14	13	12	11	10	9	8	7	6	5	4	3	2	1	0
Initial value	1	1	1	1	1	1	1	1	1	1	1	1	1	1	1	1
Read/Write	R/W	R/W	R/W	R/W	R/W	R/W	R/W	R/W	R/W	R/W	R/W	R/W	R/W	R/W	R/W	R/W
 <p>Output compare or input capture register</p>																

TCR1 Timer Control Register 1				H'FFF70				16-bit timer channel 1				
Bit	7	6	5	4	3	2	1	0				
	—	CCLR1	CCLR0	CKEG1	CKEG0	TPSC2	TPSC1	TPSC0				
Initial value	1	0	0	0	0	0	0	0				
Read/Write	—	R/W	R/W	R/W	R/W	R/W	R/W	R/W				

\*Bit functions are the same as for 16-bit timer channel 0.

TIOR1—Timer I/O Control Register 1				H'FFF71				16-bit timer channel 1				
Bit	7	6	5	4	3	2	1	0				
	—	IOB2	IOB1	IOB0	—	IOA2	IOA1	IOA0				
Initial value	1	0	0	0	1	0	0	0				
Read/Write	—	R/W	R/W	R/W	—	R/W	R/W	R/W				

\*Bit functions are the same as for 16-bit timer channel 0.

TCNT1 H/L—Timer Counter 1 H/L				H'FFF72, H'FFF73				16-bit timer channel 1								
Bit	15	14	13	12	11	10	9	8	7	6	5	4	3	2	1	0
Initial value	0	0	0	0	0	0	0	0	0	0	0	0	0	0	0	0
Read/Write	R/W	R/W	R/W	R/W	R/W	R/W	R/W	R/W	R/W	R/W	R/W	R/W	R/W	R/W	R/W	R/W

\*Bit functions are the same as for 16-bit timer channel 0.



**GRA1 H/L—General Register A1 H/L****H'FFF74, H'FFF75****16-bit timer channel 1**

Bit	15	14	13	12	11	10	9	8	7	6	5	4	3	2	1	0

Initial value	1	1	1	1	1	1	1	1	1	1	1	1	1	1	1	1
Read/Write	R/W	R/W	R/W	R/W	R/W	R/W	R/W	R/W	R/W	R/W	R/W	R/W	R/W	R/W	R/W	R/W

\*Bit functions are the same as for 16-bit timer channel 0.

**GRB1 H/L—General Register B1 H/L****H'FFF76, H'FFF77****16-bit timer channel 1**

Bit	15	14	13	12	11	10	9	8	7	6	5	4	3	2	1	0

Initial value	1	1	1	1	1	1	1	1	1	1	1	1	1	1	1	1
Read/Write	R/W	R/W	R/W	R/W	R/W	R/W	R/W	R/W	R/W	R/W	R/W	R/W	R/W	R/W	R/W	R/W

\*Bit functions are the same as for 16-bit timer channel 0.

**TCR2 Timer Control Register 2****H'FFF78****16-bit timer channel 2**

Bit	7	6	5	4	3	2	1	0
	—	CCLR1	CCLR0	CKEG1	CKEG0	TPSC2	TPSC1	TPSC0

Initial value	1	0	0	0	0	0	0	0
Read/Write	—	R/W	R/W	R/W	R/W	R/W	R/W	R/W

\*Bit functions are the same as for 16-bit timer channel 0.

Note : When phase counting mode is selected in channel 2, the settings of bits CKEG1 and CKEG0 and TPSC2 to TPSC0 in TCR2 are ignored.

TIOR2—Timer I/O Control Register 2				H'FFF79			16-bit timer channel 2		
Bit	7	6	5	4	3	2	1	0	
	—	IOB2	IOB1	IOB0	—	IOA2	IOA1	IOA0	
Initial value	1	0	0	0	1	0	0	0	
Read/Write	—	R/W	R/W	R/W	—	R/W	R/W	R/W	

\*Bit functions are the same as for 16-bit timer channel 0.

TCNT2 H/L—Timer Counter 2 H/L								H'FFF7A, H'FFF7B				16-bit timer channel 2				
Bit	15	14	13	12	11	10	9	8	7	6	5	4	3	2	1	0
Initial value	0	0	0	0	0	0	0	0	0	0	0	0	0	0	0	0
Read/Write	R/W	R/W	R/W	R/W	R/W	R/W	R/W	R/W	R/W	R/W	R/W	R/W	R/W	R/W	R/W	R/W

Phase counting mode : up / down counter  
Other mode : up - counter

GRA2 H/L—General Register A2 H/L								H'FFF7C, H'FFF7D				16-bit timer channel 2				
Bit	15	14	13	12	11	10	9	8	7	6	5	4	3	2	1	0
Initial value	1	1	1	1	1	1	1	1	1	1	1	1	1	1	1	1
Read/Write	R/W	R/W	R/W	R/W	R/W	R/W	R/W	R/W	R/W	R/W	R/W	R/W	R/W	R/W	R/W	R/W

\*Bit functions are the same as for 16-bit timer channel 0.

Bit	15	14	13	12	11	10	9	8	7	6	5	4	3	2	1	0
Initial value	1	1	1	1	1	1	1	1	1	1	1	1	1	1	1	1
Read/Write	R/W	R/W	R/W	R/W	R/W	R/W	R/W	R/W	R/W	R/W	R/W	R/W	R/W	R/W	R/W	R/W

\*Bit functions are the same as for 16-bit timer channel 0.

Bit	7	6	5	4	3	2	1	0
	CMIEB	CMIEA	OVIE	CCLR1	CCLR0	CKS2	CKS1	CKS0
Initial value	0	0	0	0	0	0	0	0
Read/Write	R/W	R/W	R/W	R/W	R/W	R/W	R/W	R/W

Clock select 2 to 0

0	0	0	Clock input is disabled
		1	Internal clock, counted on rising edge of $\phi/8$
	1	0	Internal clock, counted on rising edge of $\phi/64$
		1	Internal clock, counted on rising edge of $\phi/8192$
1	0	0	Channel 0: Count on TCNT1 overflow signal* Channel 1: Count on TCNT0 compare match A*
		1	External clock, counted on falling edge
	1	0	External clock, counted on rising edge
		1	External clock, counted on both rising and falling edges

Notes: \* If the clock input of channel 0 is the TCNT1 overflow signal and that of channel 1 is the TCNT0 compare match signal, no incrementing clock is generated. Do not use this setting.

Counter clear 1 and 0

0	0	Clearing is disabled
	1	Cleared by compare match A
1	0	Cleared by compare match B/input capture B
	1	Cleared by input capture B

Timer overflow interrupt enable

0	OVI interrupt requested by OVF is disabled
1	OVI interrupt requested by OVF is enabled

Compare match interrupt enable A

0	CMIA interrupt requested by CMFA is disabled
1	CMIA interrupt requested by CMFA is enabled

Compare match interrupt enable B

0	CMB interrupt requested by CMFB is disabled
1	CMB interrupt requested by CMFB is enabled

Bit	7	6	5	4	3	2	1	0
	CMFB	CMFA	OVF	ADTE	OIS3	OIS2	OS1	OS0
Initial value	0	0	0	0	0	0	0	0
Read/Write	R/(W)*	R/(W)*	R/(W)*	R/W	R/W	R/W	R/W	R/W

## Output select A1 and A0

Bit 1	Bit 0	Description
OS1	OS0	
0	0	No change at compare match A
	1	0 output at compare match A
1	0	1 output at compare match A
	1	Output toggles at compare match A

## Output/input capture edge select B3 and B2

ICE in TCSR1	Bit 3 OIS3	Bit 2 OIS2	Description
0	0	0	No change at compare match B
		1	0 output at compare match B
	1	0	1 output at compare match B
		1	Output toggles at compare match B
1	0	0	TCORB input capture on rising edge
		1	TCORB input capture on falling edge
	1	0	TCORB input capture on both rising and falling edges
		1	

## A/D trigger enable (TCSR0 only)

TRGE*	Bit 4 ADTE	Description
0	0	A/D converter start requests by compare match A or an external trigger are disabled
	1	A/D converter start requests by compare match A or an external trigger are enabled
1	0	A/D converter start requests by an external trigger are enabled
	1	A/D converter start requests by compare match A are enabled

Note: \* TRGE is bit 7 of the A/D control register (ADCR).

## Timer overflow flag

0	[Clearing condition] Read OVF when OVF = 1, then write 0 in OVF.
1	[Setting condition] TCNT overflows from H'FF to H'00.

## Compare match flag A

0	[Clearing condition] Read CMFA when CMFA = 1, then write 0 in CMFA.
1	[Setting condition] TCNT = TCORA

## Compare match/input capture flag B

0	[Clearing condition] Read CMFB when CMFB = 1, then write 0 in CMFB.
1	[Setting conditions] TCNT = TCORB The TCNT value is transferred to TCORB by an input capture signal when TCORB functions as an input capture register.

Note: \* Only 0 can be written to bits 7 to 5, to clear these flags.

Bit	7	6	5	4	3	2	1	0
	CMFB	CMFA	OVF	ICE	OIS3	OIS2	OS1	OS0
Initial value	0	0	0	0	0	0	0	0
Read/Write	R/(W)*	R/(W)*	R/(W)*	R/W	R/W	R/W	R/W	R/W

## Output select A1 and A0

Bit 1 OS1	Bit 0 OS0	Description
0	0	No change at compare match A
	1	0 output at compare match A
1	0	1 output at compare match A
	1	Output toggles at compare match A

## Output/input capture edge select B3 and B2

ICE in TCSR1	Bit 3 OIS3	Bit 2 OIS2	Description
0	0	0	No change at compare match B
		1	0 output at compare match B
	1	0	1 output at compare match B
		1	Output toggles at compare match B
1	0	0	TCORB input capture on rising edge
		1	TCORB input capture on falling edge
	1	0	TCORB input capture on both rising and falling edges

## Input capture enable

0	TCORB is a compare match register
1	TCORB is an input capture register

## Timer overflow flag

0	[Clearing condition] Read OVF when OVF = 1, then write 0 in OVF.
1	[Setting condition] TCNT overflows from H'FF to H'00.

## Compare match/input capture flag A

0	[Clearing condition] Read CMFA when CMFA = 1, then write 0 in CMFA.
1	[Setting condition] TCNT = TCORA

## Compare match/input capture flag B

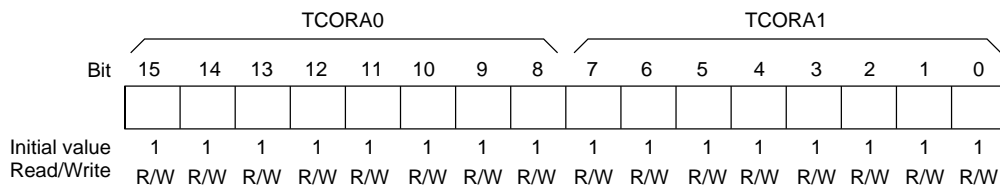
0	[Clearing condition] Read CMFB when CMFB = 1, then write 0 in CMFB.
1	[Setting conditions] TCNT = TCORB The TCNT value is transferred to TCORB by an input capture signal when TCORB functions as an input capture register.

Note: \* Only 0 can be written to bits 7 to 5, to clear these flags.

**TCORA0—Time Constant Register A0**  
**TCORA1—Time Constant Register A1**

**H'FFF84**  
**H'FFF85**

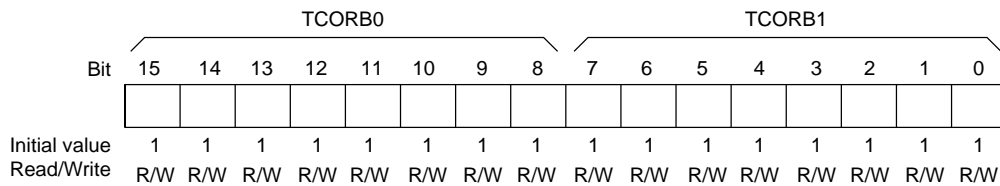
**8-bit timer channel 0**  
**8-bit timer channel 1**



**TCORB0—Time Constant Register B0**  
**TCORB1—Time Constant Register B1**

**H'FFF86**  
**H'FFF87**

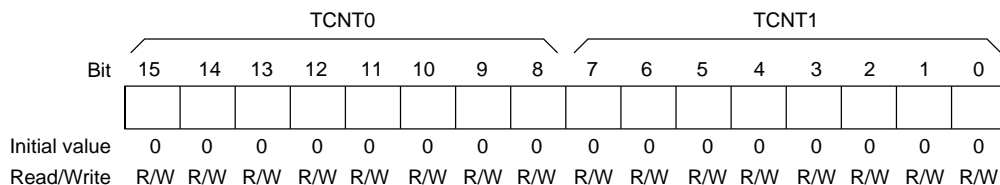
**8-bit timer channel 0**  
**8-bit timer channel 1**



**TCNT0—Timer Counter 0**  
**TCNT1—Timer Counter 1**

**H'FFF88**  
**H'FFF89**

**8-bit timer channel 0**  
**8-bit timer channel 1**



Bit	7	6	5	4	3	2	1	0
	OVF	WT/ $\bar{T}$	TME	—	—	CKS2	CKS1	CKS0
Initial value	0	0	0	1	1	0	0	0
Read/Write	R/(W)*	R/W	R/W	—	—	R/W	R/W	R/W

Clock select 2 to 0

CKS2	CKS1	CKS0	Description
0	0	0	$\phi/2$
		1	$\phi/32$
	1	0	$\phi/64$
		1	$\phi/128$
1	0	0	$\phi/256$
		1	$\phi/512$
	1	0	$\phi/2048$
		1	$\phi/4096$

Timer enable

0	Timer disabled <ul style="list-style-type: none"> <li>• TCNT is initialized to H'00 and halted</li> </ul>
1	Timer enabled <ul style="list-style-type: none"> <li>• TCNT is counting</li> </ul>

Timer mode select

0	Interval timer: requests interval timer interrupts
1	Watchdog timer: generates a reset signal

Overflow flag

0	[Clearing condition] Read OVF when OVF = 1, then write 0 in OVF
1	[Setting condition] TCNT changes from H'FF to H'00

Note: \* Only 0 can be written, to clear the flag.



TCNT—Timer Counter				H'FFF8D (read), H'FFF8C (write)				WDT
Bit	7	6	5	4	3	2	1	0
Initial value	0	0	0	0	0	0	0	0
Read/Write	R/W	R/W	R/W	R/W	R/W	R/W	R/W	R/W
				Count value				

RSTCSR—Reset Control/Status Register				H'FFF8F (read), H'FFF8E (write)				WDT
Bit	7	6	5	4	3	2	1	0
	WRST	RSTOE	—	—	—	—	—	—
Initial value	0	0	1	1	1	1	1	1
Read/Write	R/(W)*	R/W	—	—	—	—	—	—
		Reset output enable						
		0		External output of reset signal is disabled				
		1		External output of reset signal is enabled				
		Watchdog timer reset						
		0		[Clearing conditions] Reset signal at $\overline{\text{RES}}$ pin Read WRST when WRST = 1, then write 0 in WRST				
		1		[Setting condition] TCNT overflow generates a reset signal				

Note: \* Only 0 can be written in bit 7, to clear the flag.

**TCR2—Timer Control Register 2**  
**TCR3—Timer Control Register 3**

**H'FFF90**  
**H'FFF91**

**8-bit timer channel 2**  
**8-bit timer channel 3**

Bit	7	6	5	4	3	2	1	0
	CMIEB	CMIEA	OVIE	CCLR1	CCLR0	CKS2	CKS1	CKS0
Initial value	0	0	0	0	0	0	0	0
Read/Write	R/W	R/W	R/W	R/W	R/W	R/W	R/W	R/W

**Clock select 2 to 0**

CKS2	CKS1	CKS0	Description
0	0	0	Clock input is disabled
		1	Internal clock, counted on rising edge of $\phi/8$
	1	0	Internal clock, counted on rising edge of $\phi/64$
		1	Internal clock, counted on rising edge of $\phi/8192$
1	0	0	Channel 2: Count on TCNT3 overflow signal* Channel 3: Count on TCNT2 compare match A*
		1	External clock, counted on falling edge
	1	0	External clock, counted on rising edge
		1	External clock, counted on both rising and falling edges

Note: \* If the clock input of channel 2 is the TCNT3 overflow signal and that of channel 3 is the TCNT2 compare match signal, no incrementing clock is generated. Do not use this setting.

**Counter clear 1 and 0**

0	0	Clearing is disabled
	1	Cleared by compare match A
1	0	Cleared by compare match B/input capture B
	1	Cleared by input capture B

**Timer overflow interrupt enable**

0	OVI interrupt requested by OVF is disabled
1	OVI interrupt requested by OVF is enabled

**Compare match interrupt enable A**

0	CMIA interrupt requested by CMFA is disabled
1	CMIA interrupt requested by CMFA is enabled

**Compare match interrupt enable B**

0	CMIB interrupt requested by CMFB is disabled
1	CMIB interrupt requested by CMFB is enabled

TCSR2	Bit	7	6	5	4	3	2	1	0
		CMFB	CMFA	OVF	—	OIS3	OIS2	OS1	OS0
Initial value		0	0	0	1	0	0	0	0
Read/Write		R/(W)*	R/(W)*	R/(W)*	—	R/W	R/W	R/W	R/W
TCSR3	Bit	7	6	5	4	3	2	1	0
		CMFB	CMFA	OVF	ICE	OIS3	OIS2	OS1	OS0
Initial value		0	0	0	0	0	0	0	0
Read/Write		R/(W)*	R/(W)*	R/(W)*	R/W	R/W	R/W	R/W	R/W

Output select A1 and A0

Bit 1	Bit 0	Description
OS1	OS0	
0	0	No change at compare match A
	1	0 output at compare match A
1	0	1 output at compare match A
	1	Output toggles at compare match A

Output/input capture edge select B3 and B2

ICE in TCSR3	Bit 3 OIS3	Bit 3 OIS2	Description
0	0	0	
		1	0 output at compare match B
	1	0	1 output at compare match B
		1	Output toggles at compare match B
1	0	0	TCORB input capture on rising edge
		1	TCORB input capture on falling edge
	1	0	TCORB input capture on both rising and falling edges

Input capture enable (TCSR3 only)

0	TCORB is a compare match register
1	TCORB is an input capture register

Timer overflow flag

0	[Clearing condition] Read OVF when OVF = 1, then write 0 in OVF.
1	[Setting condition] TCNT overflows from H'FF to H'00.

Compare match/input capture flag A

0	[Clearing condition] Read CMFA when CMFA = 1, then write 0 in CMFA.
1	[Setting condition] TCNT = TCORA

Compare match/input capture flag B

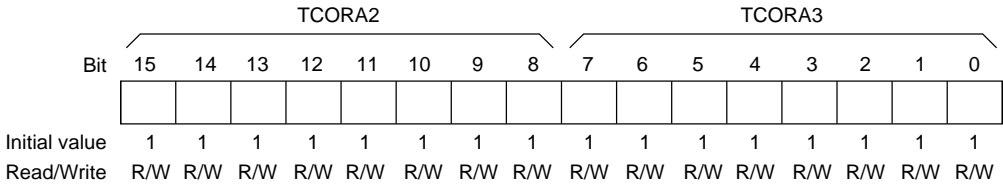
0	[Clearing condition] Read CMFB when CMFB = 1, then write 0 in CMFB.
1	[Setting conditions] TCNT = TCORB The TCNT value is transferred to TCORB by an input capture signal when TCORB functions as an input capture register.

Note: \* Only 0 can be written to bits 7 to 5, to clear these flags.

**TCORA2—Time Constant Register A2**  
**TCORA3—Time Constant Register A3**

**H'FFF94**  
**H'FFF95**

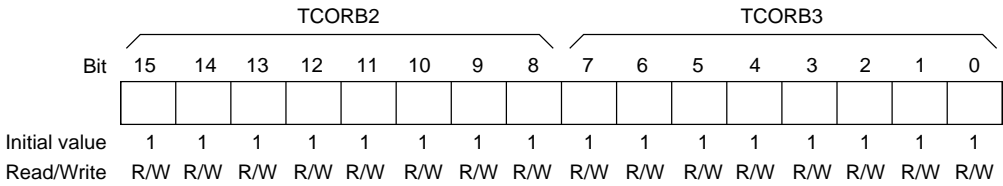
**8-bit timer channel 2**  
**8-bit timer channel 3**



**TCORB2—Time Constant Register B2**  
**TCORB3—Time Constant Register B3**

**H'FFF96**  
**H'FFF97**

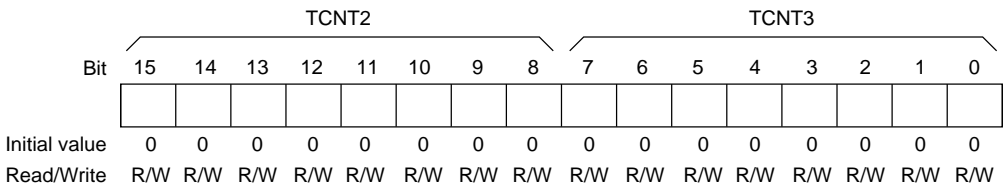
**8-bit timer channel 2**  
**8-bit timer channel 3**

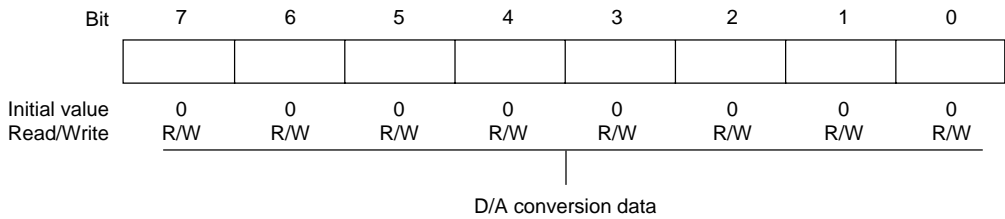
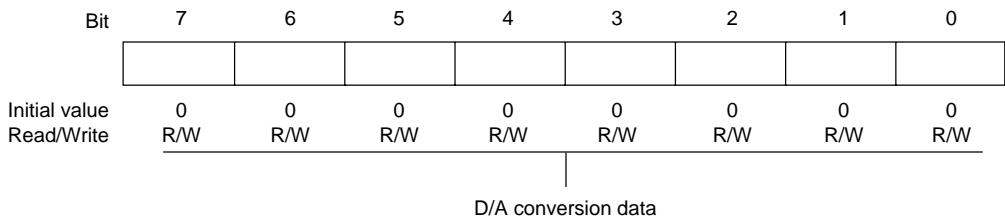


**TCNT2—Timer Counter 2**  
**TCNT3—Timer Counter 3**

**H'FFF98**  
**H'FFF99**

**8-bit timer channel 2**  
**8-bit timer channel 3**



**DADR0—D/A Data Register 0****H'FFF9C****D/A****DADR1—D/A Data Register 1****H'FFF9D****D/A**

Bit	7	6	5	4	3	2	1	0
	DAOE1	DAOE0	DAE	—	—	—	—	—
Initial value	0	0	0	1	1	1	1	1
Read/Write	R/W	R/W	R/W	—	—	—	—	—

D/A enable

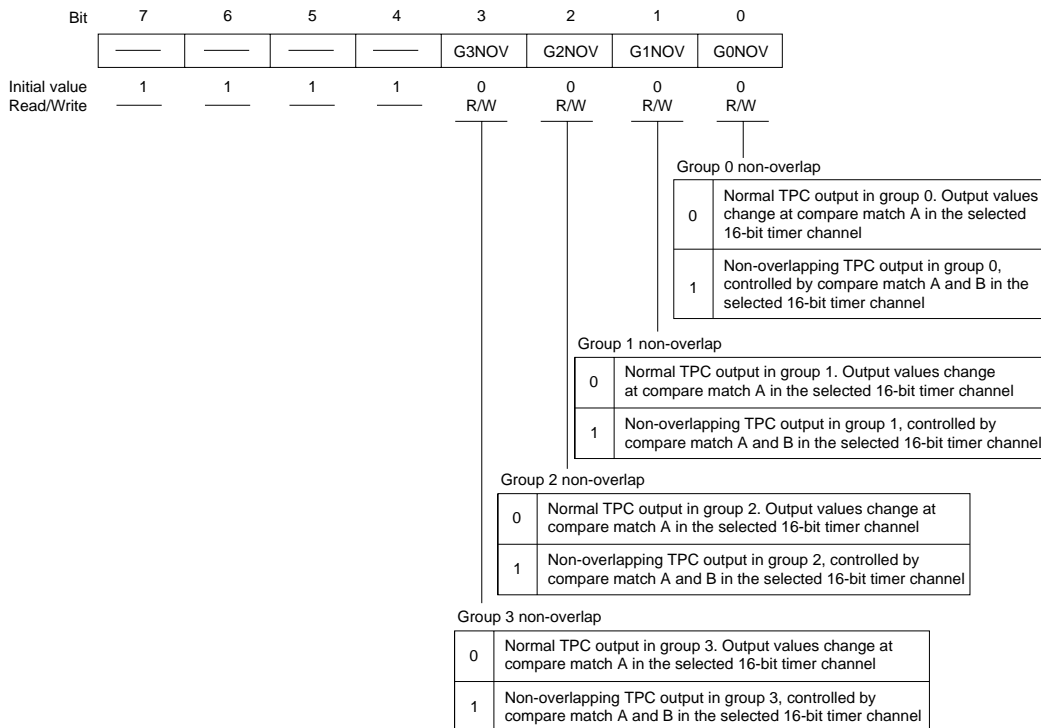
Bit 7	Bit 6	Bit 5	Description
DAOE1	DAOE0	DAE	
0	0	—	D/A conversion is disabled in channels 0 and 1
0	1	0	D/A conversion is enabled in channel 0 D/A conversion is disabled in channel 1
0	1	1	D/A conversion is enabled in channels 0 and 1
1	0	0	D/A conversion is disabled in channel 0 D/A conversion is enabled in channel 1
1	0	1	D/A conversion is enabled in channels 0 and 1
1	1	—	D/A conversion is enabled in channels 0 and 1

D/A output enable 0

0	DA0 analog output is disabled
1	Channel-0 D/A conversion and DA0 analog output are enabled

D/A output enable 1

0	DA1 analog output is disabled
1	Channel-1 D/A conversion and DA1 analog output are enabled



Bit	7	6	5	4	3	2	1	0
	G3CMS1	G3CMS0	G2CMS1	G2CMS0	G1CMS1	G1CMS0	G0CMS1	G0CMS0
Initial value	1	1	1	1	1	1	1	1
Read/Write	R/W	R/W	R/W	R/W	R/W	R/W	R/W	R/W

Group 0 compare match select 1 and 0

Bit 1	Bit 0	16-Bit Timer Channel Selected as Output Trigger
G0CMS1	G0CMS0	
0	0	TPC output group 0 (TP <sub>3</sub> to TP <sub>0</sub> ) is triggered by compare match in 16-bit timer channel 0
	1	TPC output group 0 (TP <sub>3</sub> to TP <sub>0</sub> ) is triggered by compare match in 16-bit timer channel 1
1	0	TPC output group 0 (TP <sub>3</sub> to TP <sub>0</sub> ) is triggered by compare match in 16-bit timer channel 2
	1	TPC output group 0 (TP <sub>3</sub> to TP <sub>0</sub> ) is triggered by compare match in 16-bit timer channel 2

Group 1 compare match select 1 and 0

Bit 3	Bit 2	16-Bit Timer Channel Selected as Output Trigger
G1CMS1	G1CMS0	
0	0	TPC output group 1 (TP <sub>7</sub> to TP <sub>4</sub> ) is triggered by compare match in 16-bit timer channel 0
	1	TPC output group 1 (TP <sub>7</sub> to TP <sub>4</sub> ) is triggered by compare match in 16-bit timer channel 1
1	0	TPC output group 1 (TP <sub>7</sub> to TP <sub>4</sub> ) is triggered by compare match in 16-bit timer channel 2
	1	TPC output group 1 (TP <sub>7</sub> to TP <sub>4</sub> ) is triggered by compare match in 16-bit timer channel 2

Group 2 compare match select 1 and 0

Bit 5	Bit 4	16-Bit Timer Channel Selected as Output Trigger
G2CMS1	G2CMS0	
0	0	TPC output group 2 (TP <sub>11</sub> to TP <sub>8</sub> ) is triggered by compare match in 16-bit timer channel 0
	1	TPC output group 2 (TP <sub>11</sub> to TP <sub>8</sub> ) is triggered by compare match in 16-bit timer channel 1
1	0	TPC output group 2 (TP <sub>11</sub> to TP <sub>8</sub> ) is triggered by compare match in 16-bit timer channel 2
	1	TPC output group 2 (TP <sub>11</sub> to TP <sub>8</sub> ) is triggered by compare match in 16-bit timer channel 2

Group 3 compare match select 1 and 0

Bit 7	Bit 6	16-Bit Timer Channel Selected as Output Trigger
G3CMS1	G3CMS0	
0	0	TPC output group 3 (TP <sub>15</sub> to TP <sub>12</sub> ) is triggered by compare match in 16-bit timer channel 0
	1	TPC output group 3 (TP <sub>15</sub> to TP <sub>12</sub> ) is triggered by compare match in 16-bit timer channel 1
1	0	TPC output group 3 (TP <sub>15</sub> to TP <sub>12</sub> ) is triggered by compare match in 16-bit timer channel 2
	1	TPC output group 3 (TP <sub>15</sub> to TP <sub>12</sub> ) is triggered by compare match in 16-bit timer channel 2



**NDERB—Next Data Enable Register B****H'FFFA2****TPC**

Bit	7	6	5	4	3	2	1	0
	NDER15	NDER14	NDER13	NDER12	NDER11	NDER10	NDER9	NDER8
Initial value	0	0	0	0	0	0	0	0
Read/Write	R/W	R/W	R/W	R/W	R/W	R/W	R/W	R/W

Next data enable 15 to 8

Bits 7 to 0	Description
NDER15 to NDER8	
0	TPC outputs TP <sub>15</sub> to TP <sub>8</sub> are disabled (NDR15 to NDR8 are not transferred to PB <sub>7</sub> to PB <sub>0</sub> )
1	TPC outputs TP <sub>15</sub> to TP <sub>8</sub> are enabled (NDR15 to NDR8 are transferred to PB <sub>7</sub> to PB <sub>0</sub> )

**NDERA—Next Data Enable Register A****H'FFFA3****TPC**

Bit	7	6	5	4	3	2	1	0
	NDER7	NDER6	NDER5	NDER4	NDER3	NDER2	NDER1	NDER0
Initial value	0	0	0	0	0	0	0	0
Read/Write	R/W	R/W	R/W	R/W	R/W	R/W	R/W	R/W

Next data enable 7 to 0

Bits 7 to 0	Description
NDER7 to NDER0	
0	TPC outputs TP <sub>7</sub> to TP <sub>0</sub> are disabled (NDR7 to NDR0 are not transferred to PA <sub>7</sub> to PA <sub>0</sub> )
1	TPC outputs TP <sub>7</sub> to TP <sub>0</sub> are enabled (NDR7 to NDR0 are transferred to PA <sub>7</sub> to PA <sub>0</sub> )

- Same trigger for TPC output groups 2 and 3

— Address H'FFFA4

Bit	7	6	5	4	3	2	1	0
	NDR15	NDR14	NDR13	NDR12	NDR11	NDR10	NDR9	NDR8
Initial value	0	0	0	0	0	0	0	0
Read/Write	R/W	R/W	R/W	R/W	R/W	R/W	R/W	R/W

Store the next output data for TPC output group 3    Store the next output data for TPC output group 2

— Address H'FFFA6

Bit	7	6	5	4	3	2	1	0
	_____	_____	_____	_____	_____	_____	_____	_____
Initial value	1	1	1	1	1	1	1	1
Read/Write	_____	_____	_____	_____	_____	_____	_____	_____

- Different triggers for TPC output groups 2 and 3

— Address H'FFFA4

Bit	7	6	5	4	3	2	1	0
	NDR15	NDR14	NDR13	NDR12	_____	_____	_____	_____
Initial value	0	0	0	0	1	1	1	1
Read/Write	R/W	R/W	R/W	R/W	_____	_____	_____	_____

Store the next output data for TPC output group 3

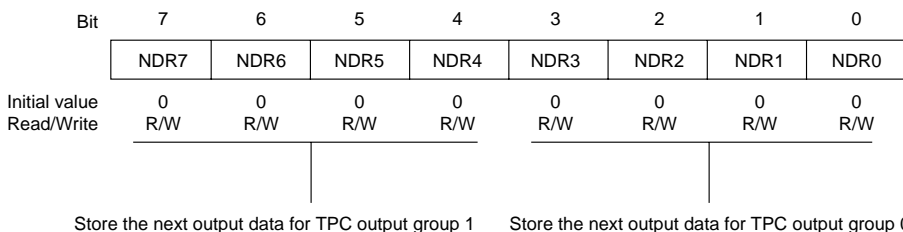
— Address H'FFFA6

Bit	7	6	5	4	3	2	1	0
	_____	_____	_____	_____	NDR11	NDR10	NDR9	NDR8
Initial value	1	1	1	1	0	0	0	0
Read/Write	_____	_____	_____	_____	R/W	R/W	R/W	R/W

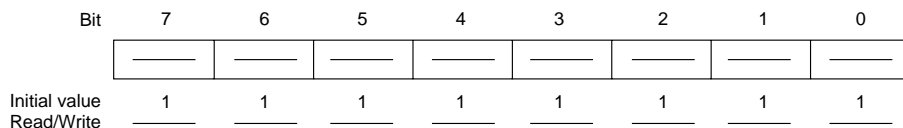
Store the next output data for TPC output group 2

- Same trigger for TPC output groups 0 and 1

— Address H'FFFA5

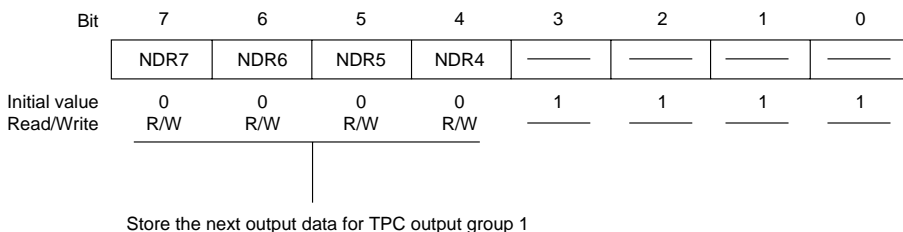


— Address H'FFFA7



- Different triggers for TPC output groups 0 and 1

— Address H'FFFA5



— Address H'FFFA7



Bit	7	6	5	4	3	2	1	0
	C/ $\bar{A}$	CHR	PE	O/ $\bar{E}$	STOP	MP	CKS1	CKS0
Initial value	0	0	0	0	0	0	0	0
Read/Write	R/W	R/W	R/W	R/W	R/W	R/W	R/W	R/W

Clock select 1 and 0

Bit 1	Bit 0	Clock Source
CKS1	CKS0	
0	0	$\phi$ clock
	1	$\phi/4$ clock
1	0	$\phi/16$ clock
	1	$\phi/64$ clock

Multiprocessor mode

0	Multiprocessor function disabled
1	Multiprocessor format selected

Stop bit length

0	One stop bit
1	Two stop bits

Parity mode

0	Even parity
1	Odd parity

Parity enable

0	Parity bit is not added or checked
1	Parity bit is added and checked

Character length

0	8-bit data
1	7-bit data

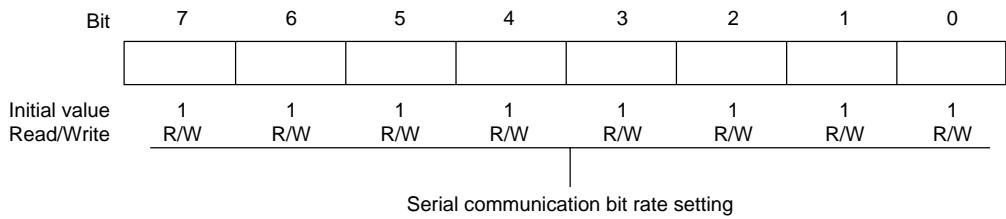
Communication mode (for serial communication interface)

0	Asynchronous mode
1	Synchronous mode

GSM mode (for smart card interface)

0	TEND flag is set 12.5 etu* after start bit
1	TEND flag is set 11.0 etu* after start bit

Note: \* etu: Elementary time unit (time required to transmit one bit)

**BRR—Bit Rate Register****H'FFFB1****SCI0**

Bit	7	6	5	4	3	2	1	0
	TIE	RIE	TE	RE	MPIE	TEIE	CKE1	CKE0
Initial value	0	0	0	0	0	0	0	0
Read/Write	R/W	R/W	R/W	R/W	R/W	R/W	R/W	R/W

Receive enable

0	Receiving is disabled
1	Receiving is enabled

Transmit enable

0	Transmitting is disabled
1	Transmitting is enabled

Clock enable 1 and 0 (for serial communication interface)

Bit 1	Bit 0	Description	
CKE1	CKE0		
0	0	Asynchronous mode	Internal clock, SCK pin available for generic I/O
		Synchronous mode	Internal clock, SCK pin used for serial clock output
	1	Asynchronous mode	Internal clock, SCK pin used for clock output
		Synchronous mode	Internal clock, SCK pin used for serial clock output
1	0	Asynchronous mode	External clock, SCK pin used for clock input
		Synchronous mode	External clock, SCK pin used for serial clock input
	1	Asynchronous mode	External clock, SCK pin used for clock input
		Synchronous mode	External clock, SCK pin used for serial clock input

Clock enable 1 and 0 (for smart card interface)

SMR	Bit 1	Bit 0	Description
GM	CKE1	CKE0	
0	0	0	SCK pin available for generic I/O
		1	SCK pin used for clock output
1	0	0	SCK pin output fixed low
		1	SCK pin used for clock output
	1	0	SCK pin output fixed high
		1	SCK pin used for clock output

Transmit-end interrupt enable

0	Transmit-end interrupt requests (TEI) are disabled
1	Transmit-end interrupt requests (TEI) are enabled

Multiprocessor interrupt enable

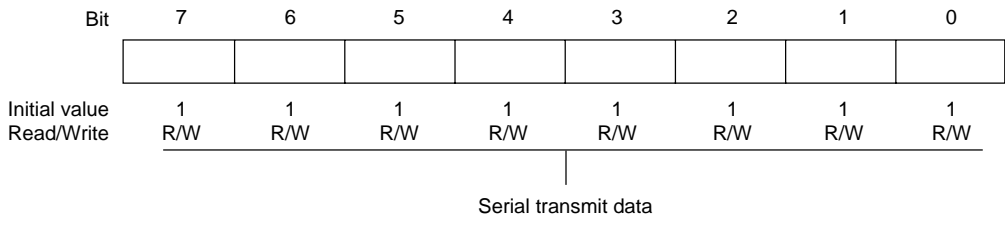
0	Multiprocessor interrupts are disabled (normal receive operation)
1	Multiprocessor interrupts are enabled

Receive interrupt enable

0	Receive-data-full (RXI) and receive-error (ERI) interrupt requests are disabled
1	Receive-data-full (RXI) and receive-error (ERI) interrupt requests are enabled

Transmit interrupt enable

0	Transmit-data-empty interrupt request (TXI) is disabled
1	Transmit-data-empty interrupt request (TXI) is enabled



Bit	7	6	5	4	3	2	1	0
	TDRE	RDRF	ORER	FER/ERS	PER	TEND	MPB	MPBT
Initial value	1	0	0	0	0	1	0	0
Read/Write	R/(W)*	R/(W)*	R/(W)*	R/(W)*	R/(W)*	R	R	R/W

Multiprocessor bit transfer	
0	Multiprocessor bit value in transmit data is 0
1	Multiprocessor bit value in transmit data is 1

Multiprocessor bit	
0	Multiprocessor bit value in receive data is 0
1	Multiprocessor bit value in receive data is 1

Transmit end (for serial communication interface)

0	[Clearing conditions] Read TDRE when TDRE = 1, then write 0 in TDRE. The DMAC writes data in TDR.
1	[Setting conditions] Reset or transition to standby mode TE is cleared to 0 in SCR. TDRE is 1 when last bit of 1-byte serial character is transmitted.

Transmit end (for smart card interface)

0	[Clearing conditions] Read TDRE when TDRE = 1, then write 0 in TDRE. The DMAC writes data in TDR.
1	[Setting conditions] Reset or transition to standby mode TE is cleared to 0 in SCR and FER/ERS is cleared to 0. TDRE is 1 and FER/ERS is 0 (normal transmission) 2.5 etu* (when GM = 0) or 1.0 etu (when GM = 1) after 1-byte serial character is transmitted.

Note: \* etu: Elementary time unit (time required to transmit one bit)

Parity error

0	[Clearing conditions] Reset or transition to standby mode Read PER when PER = 1, then write 0 in PER.
1	[Setting condition] Parity error (parity of receive data does not match parity setting of O/E bit in SMR)

Framing error (for serial communication interface)

0	[Clearing conditions] Reset or transition to standby mode Read FER when FER = 1, then write 0 in FER.
1	[Setting condition] Framing error (stop bit is 0)

Error signal status (for smart card interface)

0	[Clearing conditions] Reset or transition to standby mode Read ERS when ERS = 1, then write 0 in ERS.
1	[Setting condition] A low error signal is received.

Overrun error

0	[Clearing conditions] Reset or transition to standby mode Read ORER when ORER = 1, then write 0 in ORER.
1	[Setting condition] Overrun error (reception of the next serial data ends when RDRF = 1)

Receive data register full

0	[Clearing conditions] Reset or transition to standby mode Read RDRF when RDRF = 1, then write 0 in RDRF. The DMAC reads data from RDR.
1	[Setting condition] Serial data is received normally and transferred from RSR to RDR.

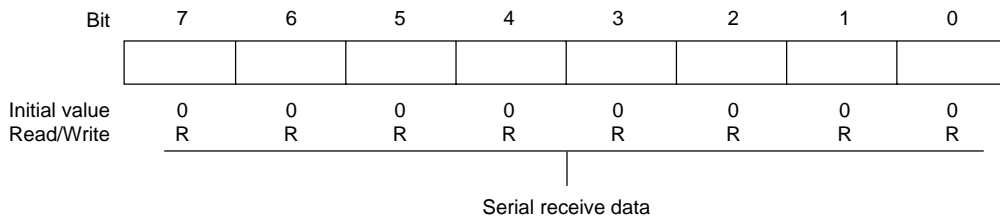
  

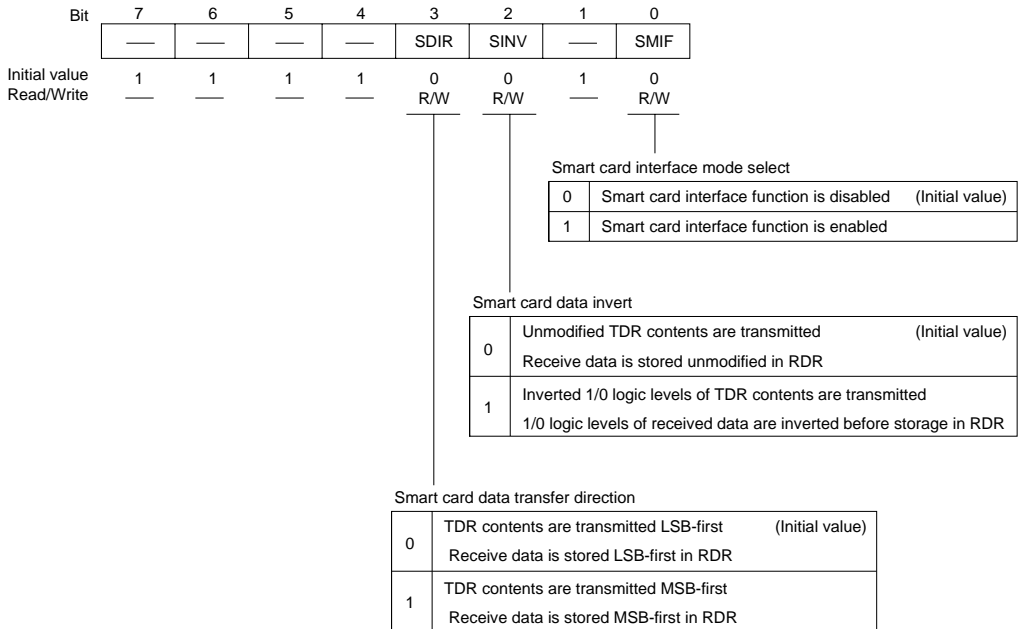
Transmit data register empty

0	[Clearing conditions] Read TDRE when TDRE = 1, then write 0 in TDRE. The DMAC writes data in TDR.
1	[Setting conditions] Reset or transition to standby mode TE is 0 in SCR. Data is transferred from TDR to TSR, enabling new data to be written in TDR

Note: \* Only 0 can be written, to clear the flag.







**SMR—Serial Mode Register****H'FFFB8****SCI1**

Bit	7	6	5	4	3	2	1	0
	C/ $\bar{A}$	CHR	PE	O/ $\bar{E}$	STOP	MP	CKS1	CKS0
Initial value	0	0	0	0	0	0	0	0
Read/Write	R/W	R/W	R/W	R/W	R/W	R/W	R/W	R/W

Note: Bit functions are the same as for SCI0.

**BRR—Bit Rate Register****H'FFFB9****SCI1**

Bit	7	6	5	4	3	2	1	0
Initial value	1	1	1	1	1	1	1	1
Read/Write	R/W	R/W	R/W	R/W	R/W	R/W	R/W	R/W

Note: Bit functions are the same as for SCI0.

**SCR—Serial Control Register****H'FFFB A****SCI1**

Bit	7	6	5	4	3	2	1	0
	TIE	RIE	TE	RE	MPIE	TEIE	CKE1	CKE0
Initial value	0	0	0	0	0	0	0	0
Read/Write	R/W	R/W	R/W	R/W	R/W	R/W	R/W	R/W

Note: Bit functions are the same as for SCI0.

**TDR—Transmit Data Register****H'FFFBB****SCI1**

Bit	7	6	5	4	3	2	1	0
Initial value	1	1	1	1	1	1	1	1
Read/Write	R/W	R/W	R/W	R/W	R/W	R/W	R/W	R/W

Note: Bit functions are the same as for SCI0.

**SSR—Serial Status Register****H'FFFBC****SCI1**

Bit	7	6	5	4	3	2	1	0
	TDRE	RDRF	ORER	FER/ERS	PER	TEND	MPB	MPBT
Initial value	0	0	0	0	0	1	0	0
Read/Write	R/(W)*	R/(W)*	R/(W)*	R/(W)*	R/(W)*	R	R	R/W

Note: Bit functions are the same as for SCI0.

\* Only 0 can be written, to clear the flag.

**RDR—Receive Data Register****H'FFFBD****SCI1**

Bit	7	6	5	4	3	2	1	0
Initial value	0	0	0	0	0	0	0	0
Read/Write	R	R	R	R	R	R	R	R

Note: Bit functions are the same as for SCI0.

Bit	7	6	5	4	3	2	1	0
	—	—	—	—	SDIR	SINV	—	SMIF
Initial value	1	1	1	1	0	0	1	0
Read/Write	—	—	—	—	R/W	R/W	—	R/W

Note: Bit functions are the same as for SCI0.

**SMR—Serial Mode Register****H'FFFC0****SCI2**

Bit	7	6	5	4	3	2	1	0
	C/ $\bar{A}$	CHR	PE	O/ $\bar{E}$	STOP	MP	CKS1	CKS0
Initial value	0	0	0	0	0	0	0	0
Read/Write	R/W	R/W	R/W	R/W	R/W	R/W	R/W	R/W

Note: Bit functions are the same as for SCI0.

**BRR—Bit Rate Register****H'FFFC1****SCI2**

Bit	7	6	5	4	3	2	1	0
Initial value	1	1	1	1	1	1	1	1
Read/Write	R/W	R/W	R/W	R/W	R/W	R/W	R/W	R/W

Note: Bit functions are the same as for SCI0.

**SCR—Serial Control Register****H'FFFC2****SCI2**

Bit	7	6	5	4	3	2	1	0
	TIE	RIE	TE	RE	MPIE	TEIE	CKE1	CKE0
Initial value	0	0	0	0	0	0	0	0
Read/Write	R/W	R/W	R/W	R/W	R/W	R/W	R/W	R/W

Note: Bit functions are the same as for SCI0.

TDR—Transmit Data Register					H'FFFC3	SCI2		
Bit	7	6	5	4	3	2	1	0
Initial value	1	1	1	1	1	1	1	1
Read/Write	R/W	R/W	R/W	R/W	R/W	R/W	R/W	R/W

Note: Bit functions are the same as for SCI0.

SSR—Serial Status Register					H'FFFC4	SCI2		
Bit	7	6	5	4	3	2	1	0
	TDRE	RDRF	ORER	FER/ERS	PER	TEND	MPB	MPBT
Initial value	1	0	0	0	0	1	0	0
Read/Write	R/(W)*	R/(W)*	R/(W)*	R/(W)*	R/(W)*	R	R	R/W

Note: Bit functions are the same as for SCI0.  
 \* Only 0 can be written, to clear the flag.

RDR—Receive Data Register					H'FFFC5	SCI2		
Bit	7	6	5	4	3	2	1	0
Initial value	0	0	0	0	0	0	0	0
Read/Write	R	R	R	R	R	R	R	R

Note: Bit functions are the same as for SCI0.

Bit	7	6	5	4	3	2	1	0
	—	—	—	—	SDIR	SINV	—	SMIF
Initial value	1	1	1	1	0	0	1	0
Read/Write	—	—	—	—	R/W	R/W	—	R/W

Note: Bit functions are the same as for SCI0.



P1DR—Port 1 Data Register					H'FFFD0	Port 1		
Bit	7	6	5	4	3	2	1	0
	P17	P16	P15	P14	P13	P12	P11	P10
Initial value	0	0	0	0	0	0	0	0
Read/Write	R/W	R/W	R/W	R/W	R/W	R/W	R/W	R/W

P2DR—Port 2 Data Register					H'FFFD1	Port 2		
Bit	7	6	5	4	3	2	1	0
	P27	P26	P25	P24	P23	P22	P21	P20
Initial value	0	0	0	0	0	0	0	0
Read/Write	R/W	R/W	R/W	R/W	R/W	R/W	R/W	R/W

P3DR—Port 3 Data Register					H'FFFD2	Port 3		
Bit	7	6	5	4	3	2	1	0
	P37	P36	P35	P34	P33	P32	P31	P30
Initial value	0	0	0	0	0	0	0	0
Read/Write	R/W	R/W	R/W	R/W	R/W	R/W	R/W	R/W

P4DR—Port 4 Data Register					H'FFFD3	Port 4		
Bit	7	6	5	4	3	2	1	0
	P47	P46	P45	P44	P43	P42	P41	P40
Initial value	0	0	0	0	0	0	0	0
Read/Write	R/W	R/W	R/W	R/W	R/W	R/W	R/W	R/W
Data for port 4 pins								

P5DR—Port 5 Data Register					H'FFFD4	Port 5		
Bit	7	6	5	4	3	2	1	0
	—	—	—	—	P53	P52	P51	P50
Initial value	1	1	1	1	0	0	0	0
Read/Write	—	—	—	—	R/W	R/W	R/W	R/W
Data for port 5 pins								

P6DR—Port 6 Data Register					H'FFFD5	Port 6		
Bit	7	6	5	4	3	2	1	0
	P67	P66	P65	P64	P63	P62	P61	P60
Initial value	1	0	0	0	0	0	0	0
Read/Write	R	R/W	R/W	R/W	R/W	R/W	R/W	R/W
Data for port 6 pins								

**P7DR—Port 7 Data Register****H'FFFD6****Port 7**

Bit	7	6	5	4	3	2	1	0
	P77	P76	P75	P74	P73	P72	P71	P70
Initial value	—	—	—	—	—	—	—	—
Read/Write	R	R	R	R	R	R	R	R

Data for port 7 pins

Note: \* Determined by pins P77 to P70.

**P8DR—Port 8 Data Register****H'FFFD7****Port 8**

Bit	7	6	5	4	3	2	1	0
	—	—	—	P84	P83	P82	P81	P80
Initial value	1	1	1	0	0	0	0	0
Read/Write	—	—	—	R/W	R/W	R/W	R/W	R/W

Data for port 8 pins

P9DR—Port 9 Data Register					H'FFFD8	Port 9		
Bit	7	6	5	4	3	2	1	0
	—	—	P95	P94	P93	P92	P91	P90
Initial value	1	1	0	0	0	0	0	0
Read/Write	—	—	R/W	R/W	R/W	R/W	R/W	R/W
Data for port 9 pins								

PADR—Port A Data Register					H'FFFD9	Port A		
Bit	7	6	5	4	3	2	1	0
	PA7	PA6	PA5	PA4	PA3	PA2	PA1	PA0
Initial value	0	0	0	0	0	0	0	0
Read/Write	R/W	R/W	R/W	R/W	R/W	R/W	R/W	R/W
Data for port A pins								

PBDR—Port B Data Register					H'FFFDA	Port B		
Bit	7	6	5	4	3	2	1	0
	PB7	PB6	PB5	PB4	PB3	PB2	PB1	PB0
Initial value	0	0	0	0	0	0	0	0
Read/Write	R/W	R/W	R/W	R/W	R/W	R/W	R/W	R/W
Data for port B pins								

**ADDRA H/L—A/D Data Register A H/L**
**H'FFFE0, H'FFFE1**
**A/D**

Bit	15	14	13	12	11	10	9	8	7	6	5	4	3	2	1	0
	AD9	AD8	AD7	AD6	AD5	AD4	AD3	AD2	AD1	AD0	—	—	—	—	—	—
Initial value	0	0	0	0	0	0	0	0	0	0	0	0	0	0	0	0
Read/Write	R	R	R	R	R	R	R	R	R	R	R	R	R	R	R	R
	└──────────────────────────────────┘									└──────────────────────────────────┘						
	ADDRAH									ADDRAL						

A/D conversion data

10-bit data giving an A/D conversion result

**ADDRB H/L—A/D Data Register B H/L**
**H'FFFE2, H'FFFE3**
**A/D**

Bit	15	14	13	12	11	10	9	8	7	6	5	4	3	2	1	0
	AD9	AD8	AD7	AD6	AD5	AD4	AD3	AD2	AD1	AD0	—	—	—	—	—	—
Initial value	0	0	0	0	0	0	0	0	0	0	0	0	0	0	0	0
Read/Write	R	R	R	R	R	R	R	R	R	R	R	R	R	R	R	R
	└──────────────────────────────────┘									└──────────────────────────────────┘						
	ADDRBH									ADDRBL						

A/D conversion data

10-bit data giving an A/D conversion result

ADDRC H/L—A/D Data Register C H/L											H'FFFE4, H'FFFE5					A/D
Bit	15	14	13	12	11	10	9	8	7	6	5	4	3	2	1	0
	AD9	AD8	AD7	AD6	AD5	AD4	AD3	AD2	AD1	AD0	—	—	—	—	—	—
Initial value	0	0	0	0	0	0	0	0	0	0	0	0	0	0	0	0
Read/Write	R	R	R	R	R	R	R	R	R	R	R	R	R	R	R	R
	ADDRCH										ADDRCL					
<hr/> <b>A/D conversion data</b> 10-bit data giving an A/D conversion result																

ADDRD H/L—A/D Data Register D H/L											H'FFFE6, H'FFFE7					A/D
Bit	15	14	13	12	11	10	9	8	7	6	5	4	3	2	1	0
	AD9	AD8	AD7	AD6	AD5	AD4	AD3	AD2	AD1	AD0	—	—	—	—	—	—
Initial value	0	0	0	0	0	0	0	0	0	0	0	0	0	0	0	0
Read/Write	R	R	R	R	R	R	R	R	R	R	R	R	R	R	R	R
	ADDRDH										ADDRDL					
<hr/> <b>A/D conversion data</b> 10-bit data giving an A/D conversion result																

ADCR—A/D Control Register								H'FFFE9		A/D
Bit	7	6	5	4	3	2	1	0		
	TRGE	—	—	—	—	—	—	—		
Initial value	0	1	1	1	1	1	1	0		
Read/Write	R/W	—	—	—	—	—	—	R/W		
<hr/> Trigger Enable										
	0	A/D conversion start by external trigger or 8-bit timer compare match is disabled								
	1	A/D conversion is started by falling edge of external trigger signal (ADTRG) or 8-bit timer compare match								

Bit	7	6	5	4	3	2	1	0
	ADF	ADIE	ADST	SCAN	CKS	CH2	CH1	CH0
Initial value	0	0	0	0	0	0	0	0
Read/Write	R/(W)*	R/W	R/W	R/W	R/W	R/W	R/W	R/W

Clock select		Channel select 2 to 0			
		Group Selection	Channel Selection	Description	
0	Conversion time = 134 states (maximum)	CH2	CH1	CH0	Single Mode Scan Mode
1	Conversion time = 70 states (maximum)				
		0	0	0	AN <sub>0</sub> AN <sub>0</sub>
			1	1	AN <sub>1</sub> AN <sub>0</sub> , AN <sub>1</sub>
			0	0	AN <sub>2</sub> AN <sub>0</sub> to AN <sub>2</sub>
			1	1	AN <sub>3</sub> AN <sub>0</sub> to AN <sub>3</sub>
		1	0	0	AN <sub>4</sub> AN <sub>4</sub>
			1	1	AN <sub>5</sub> AN <sub>4</sub> , AN <sub>5</sub>
			0	0	AN <sub>6</sub> AN <sub>4</sub> to AN <sub>6</sub>
			1	1	AN <sub>7</sub> AN <sub>4</sub> to AN <sub>7</sub>

Scan mode	
0	Single mode
1	Scan mode

A/D start	
0	A/D conversion is stopped
1	Single mode: A/D conversion starts; ADST is automatically cleared to 0 when conversion ends Scan mode: A/D conversion starts and continues, cycling among the selected channels ADST is cleared to 0 by software, by a reset, or by a transition to standby mode

A/D interrupt enable	
0	A/D end interrupt request is disabled
1	A/D end interrupt request is enabled

A/D end flag	
0	[Clearing condition] Read ADF when ADF = 1, then write 0 in ADF The DMAC is activated by an ADI interrupt
1	[Setting conditions] Single mode: A/D conversion ends Scan mode: A/D conversion ends in all selected channels

Note: \* Only 0 can be written, to clear the flag.

# Appendix C I/O Port Block Diagrams

## C.1 Port 1 Block Diagram

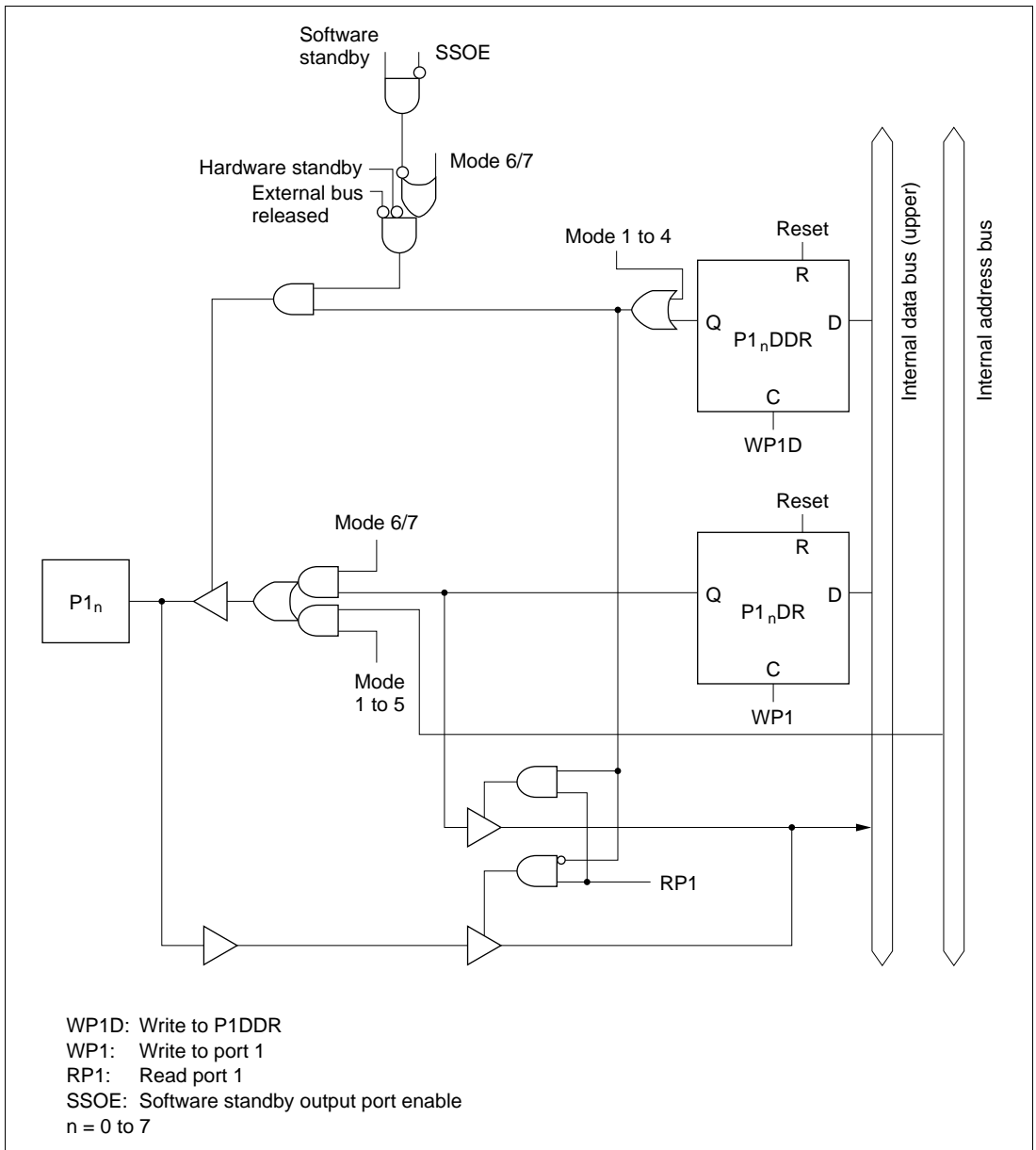


Figure C.1 Port 1 Block Diagram



## C.2 Port 2 Block Diagram

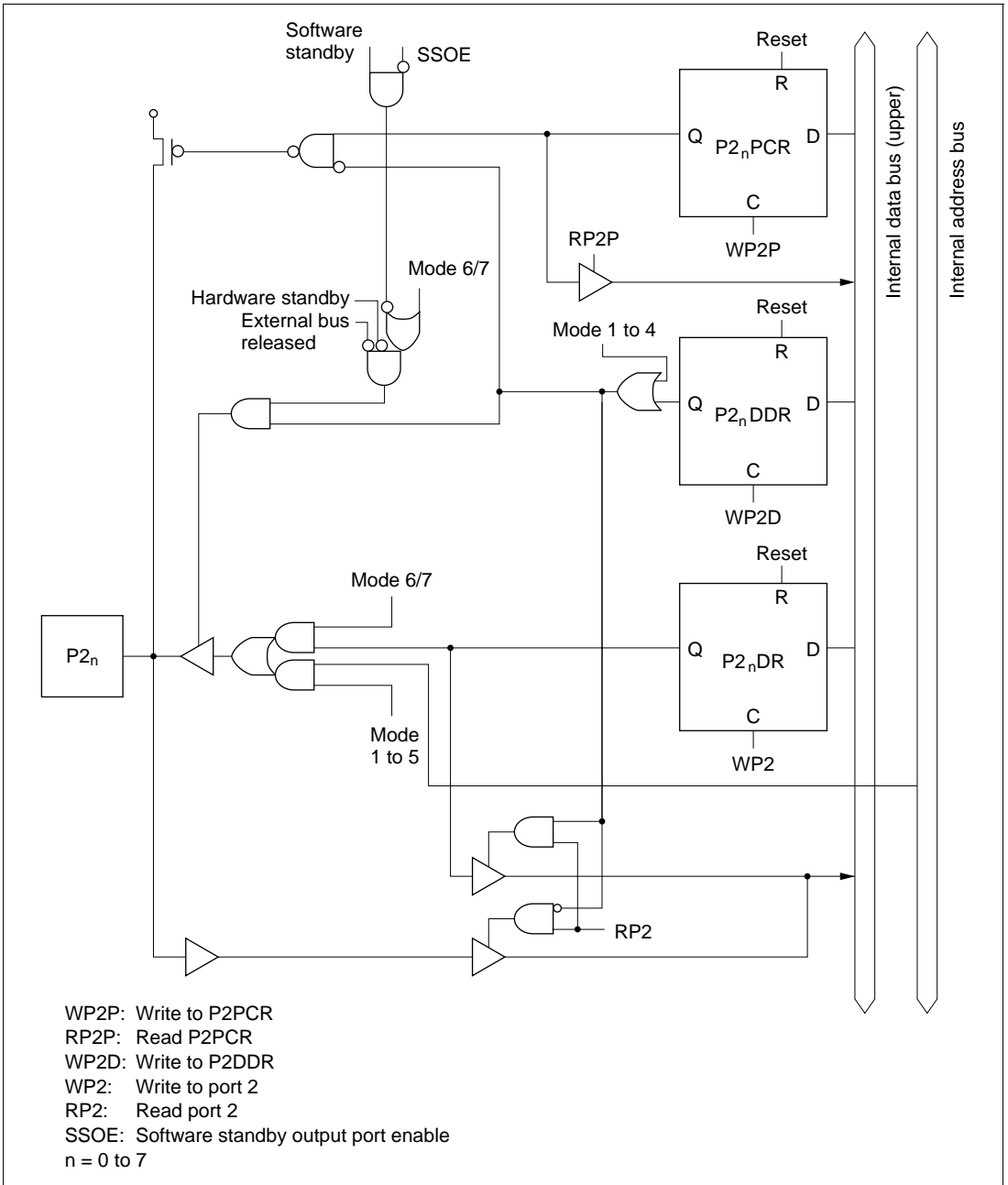


Figure C.2 Port 2 Block Diagram



## C.4 Port 4 Block Diagram

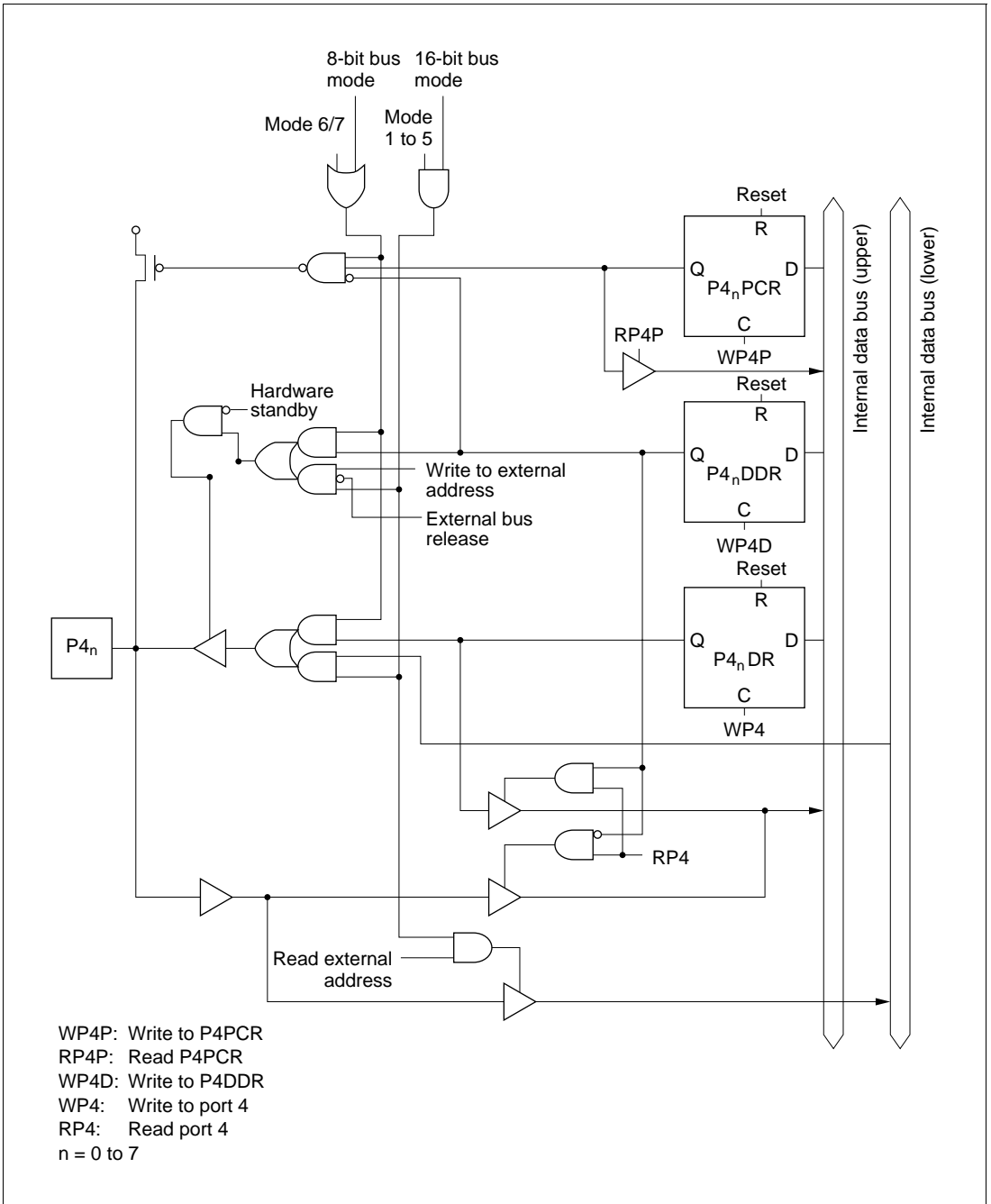


Figure C.4 Port 4 Block Diagram

## C.5 Port 5 Block Diagram

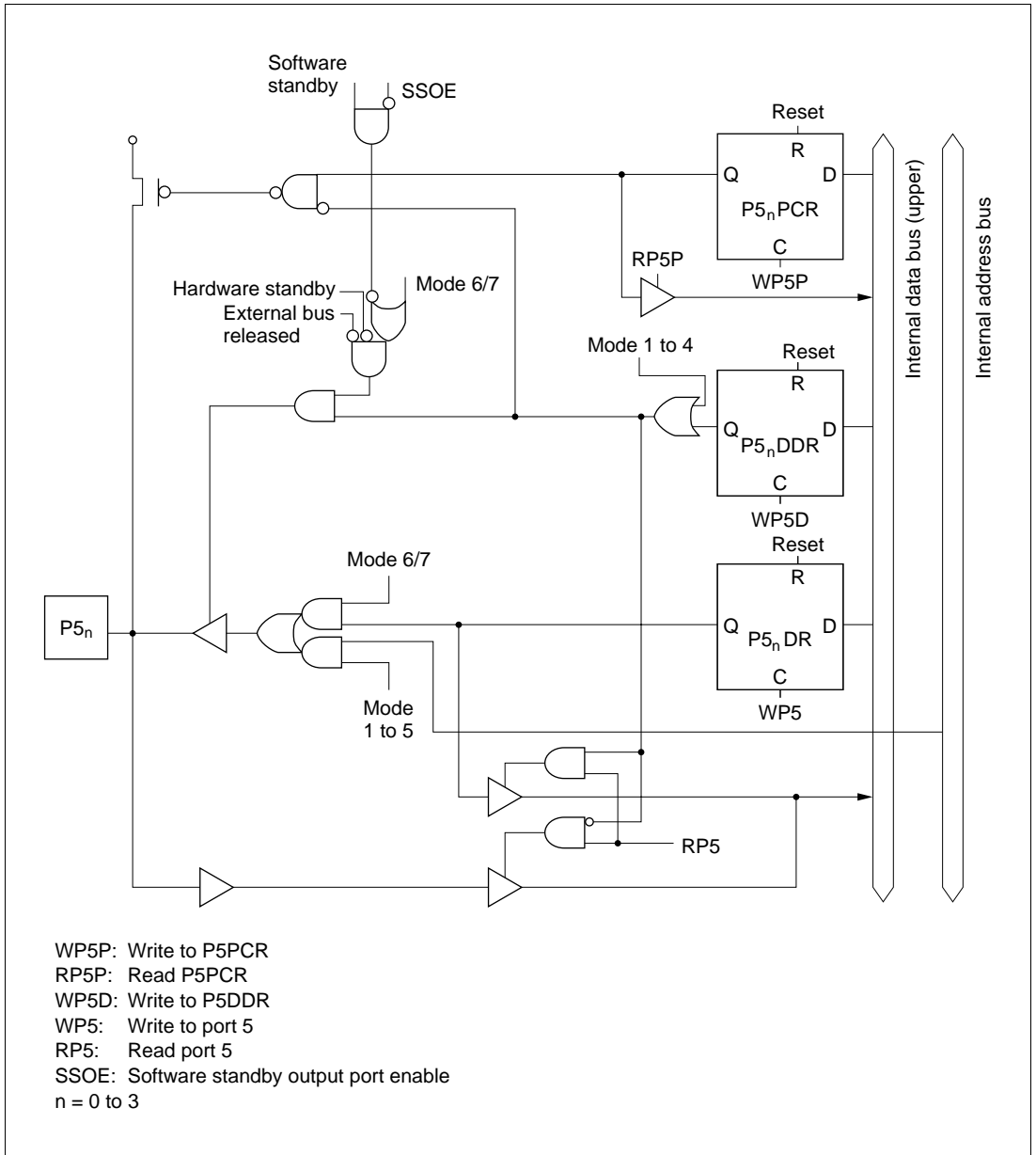
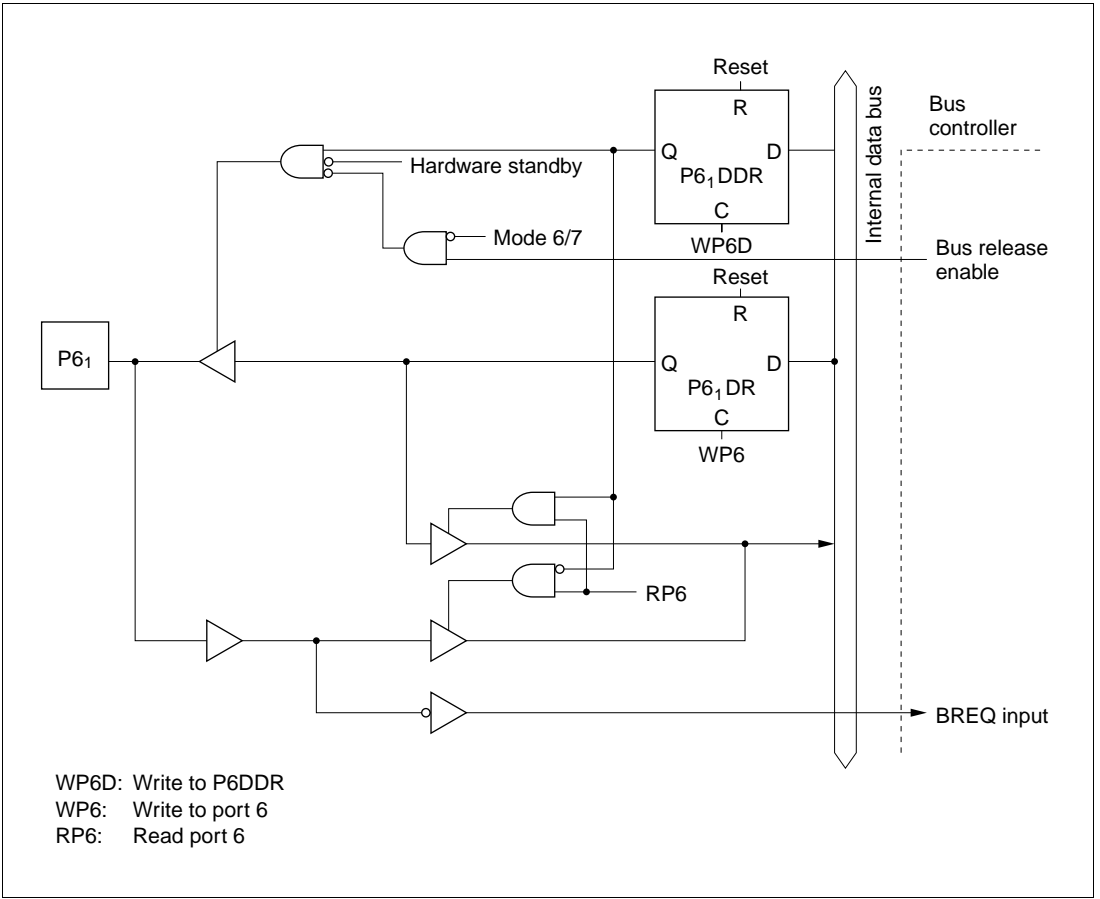
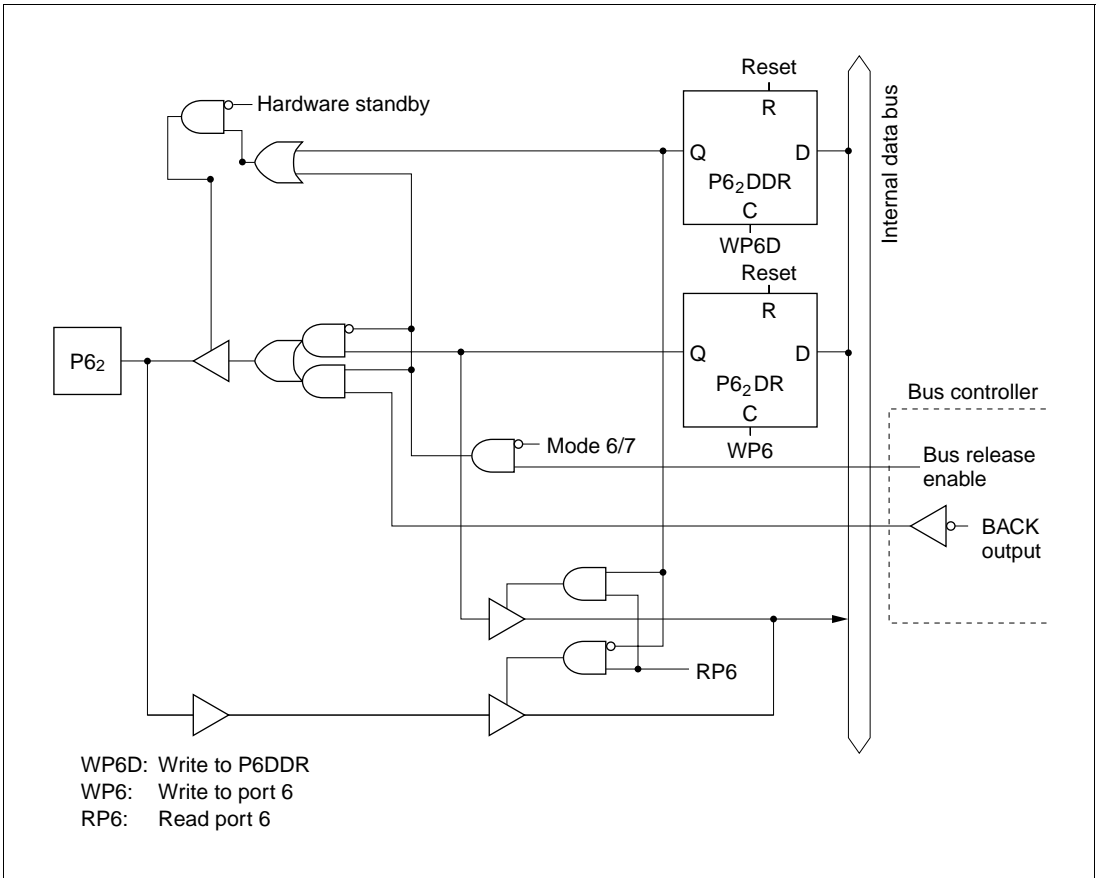


Figure C.5 Port 5 Block Diagram





**Figure C.6 (b) Port 6 Block Diagram (Pin P6<sub>1</sub>)**



**Figure C.6 (c) Port 6 Block Diagram (Pin P6<sub>2</sub>)**





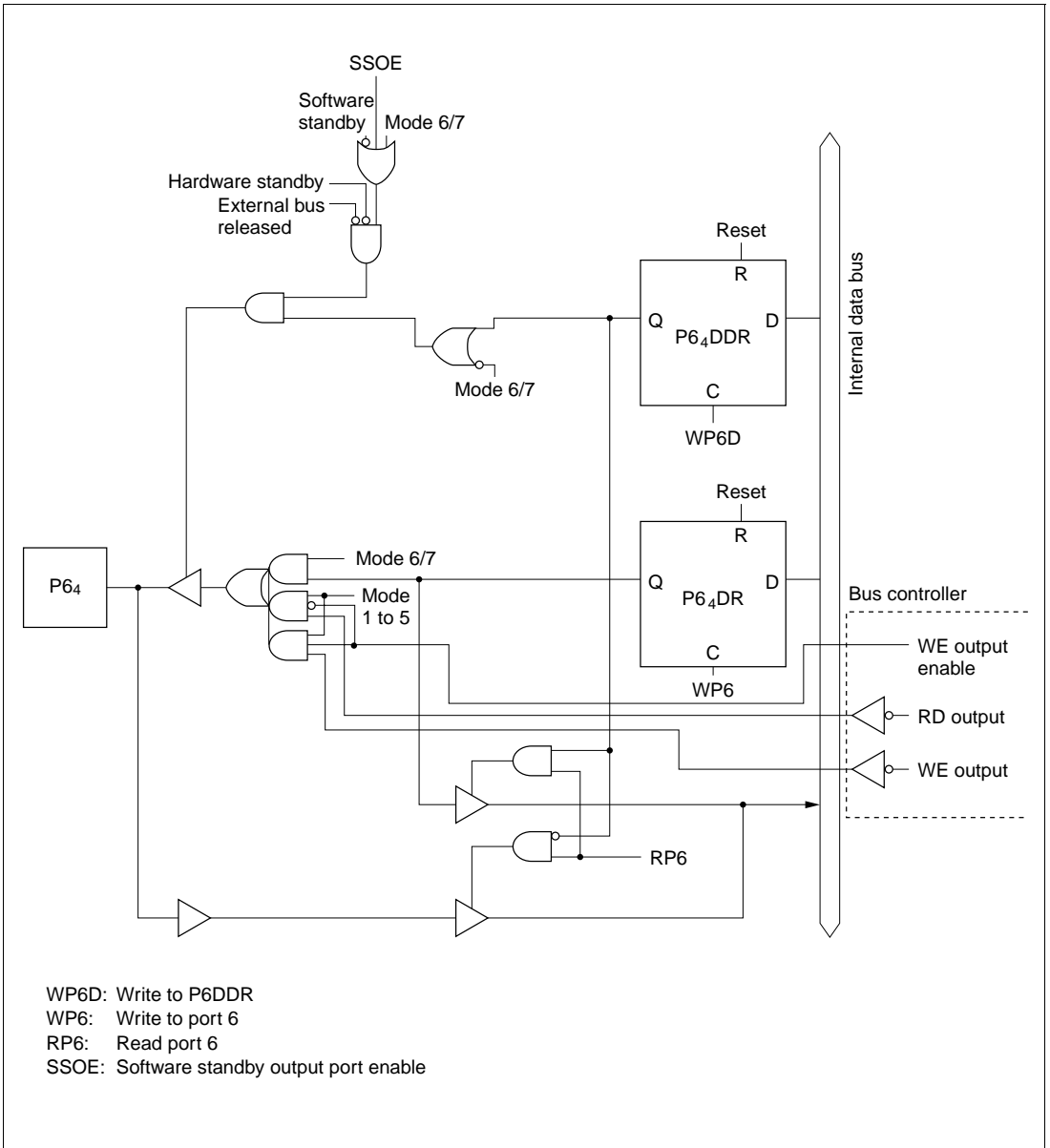
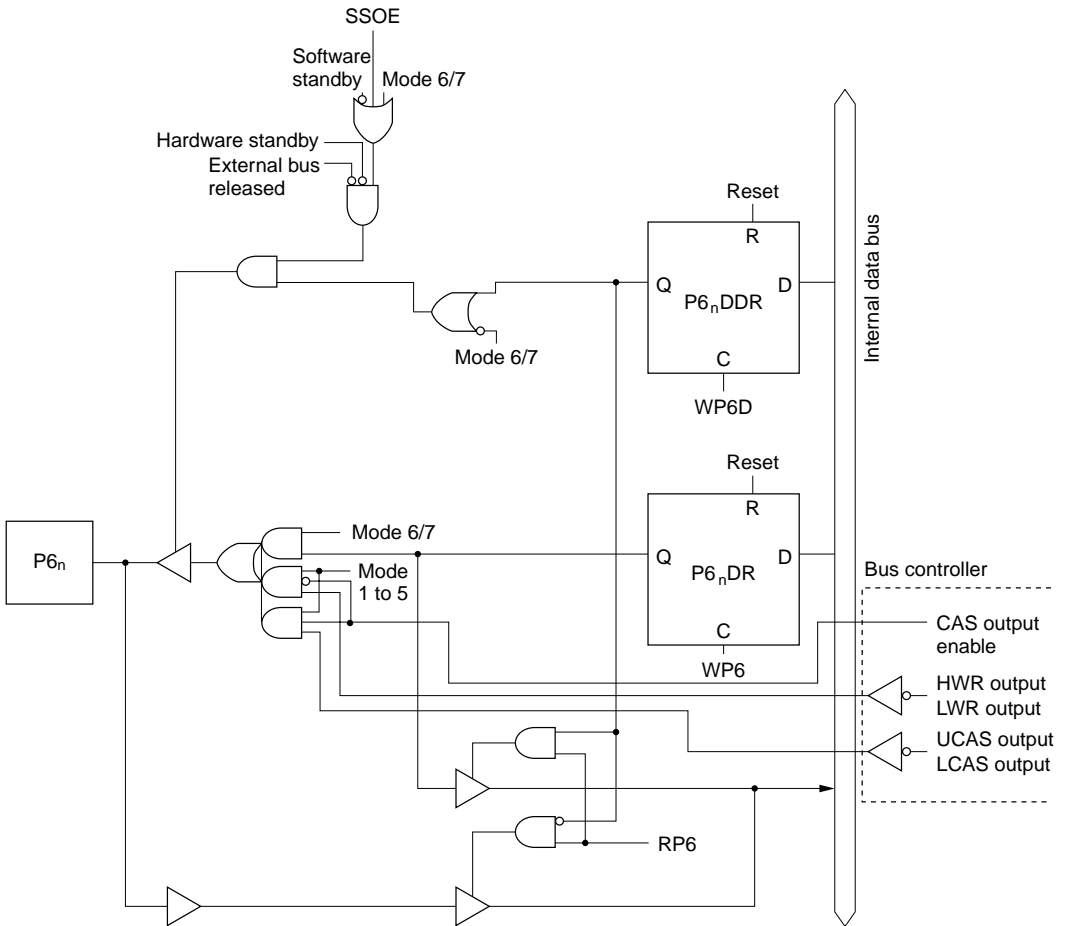
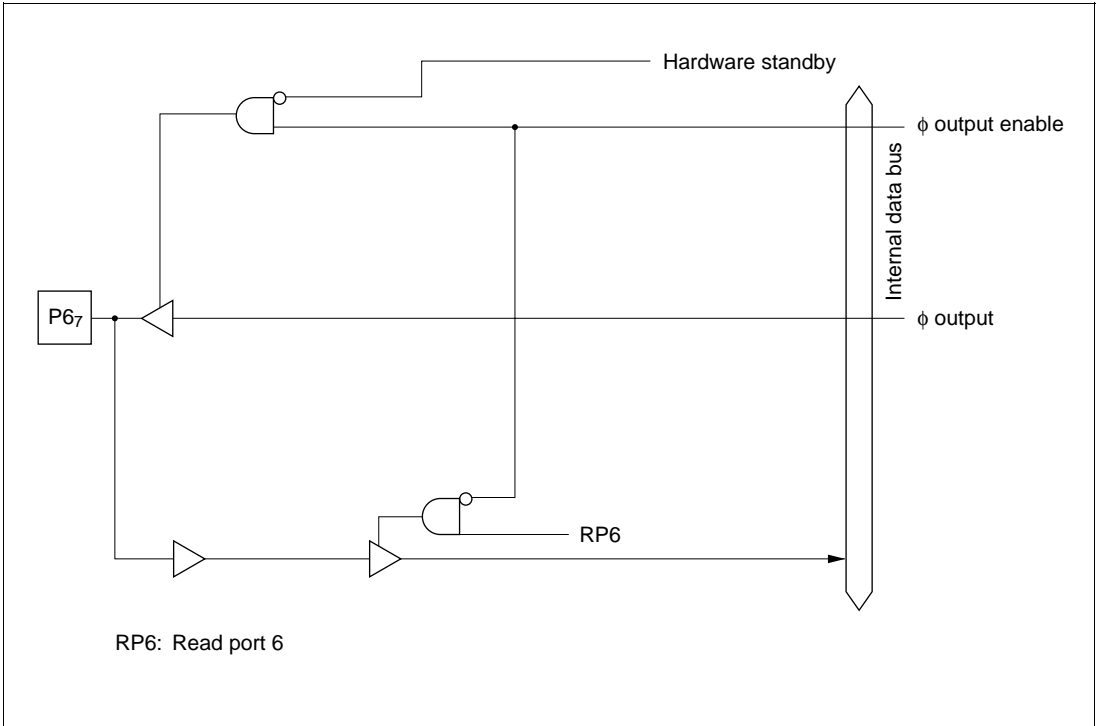


Figure C.6 (e) Port 6 Block Diagram (Pin P6<sub>4</sub>)



WP6D: Write to P6DDR  
 WP6: Write to port 6  
 RP6: Read port 6  
 SSOE: Software standby output port enable  
 n = 5 and 6

**Figure C.6 (f) Port 6 Block Diagram (Pins P6<sub>5</sub> and P6<sub>6</sub>)**



**Figure C.6 (g) Port 6 Block Diagram (Pin P67)**

## C.7 Port 7 Block Diagrams

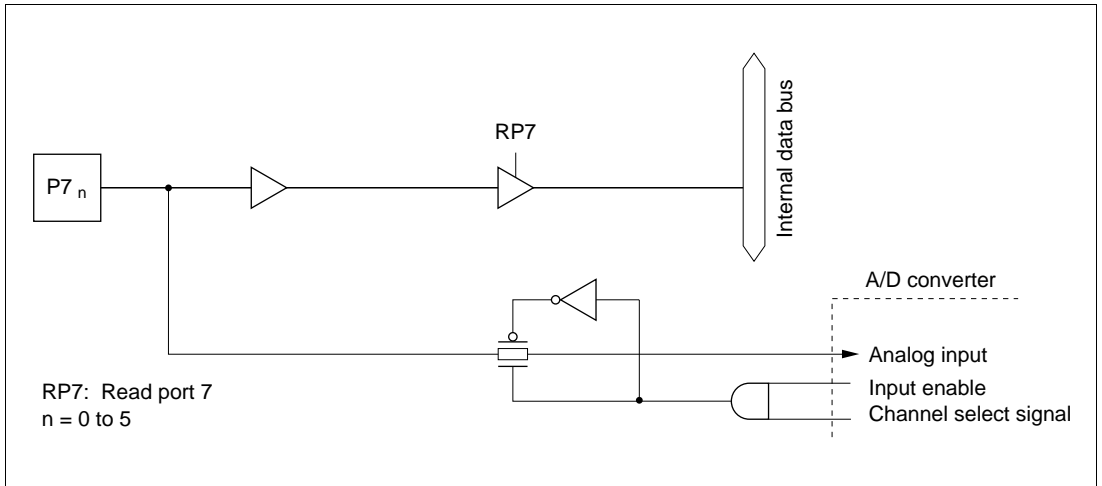


Figure C.7 (a) Port 7 Block Diagram (Pins P7<sub>0</sub> to P7<sub>5</sub>)

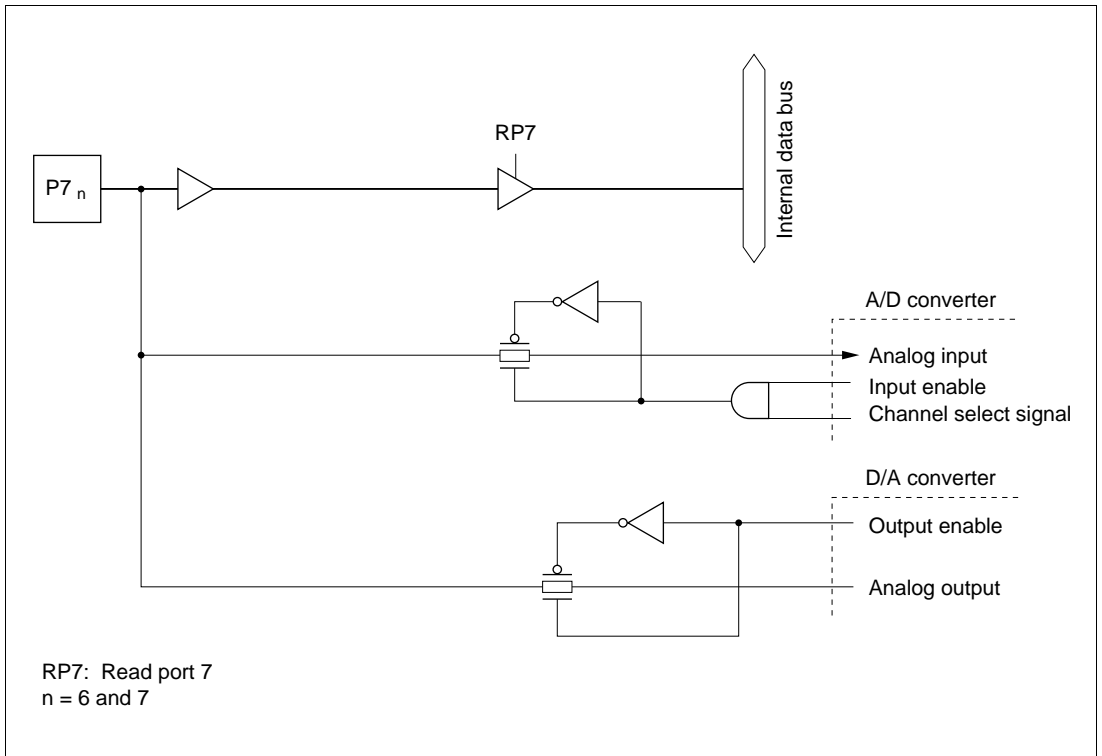


Figure C.7 (b) Port 7 Block Diagram (Pins P7<sub>6</sub> and P7<sub>7</sub>)

## C.8 Port 8 Block Diagrams

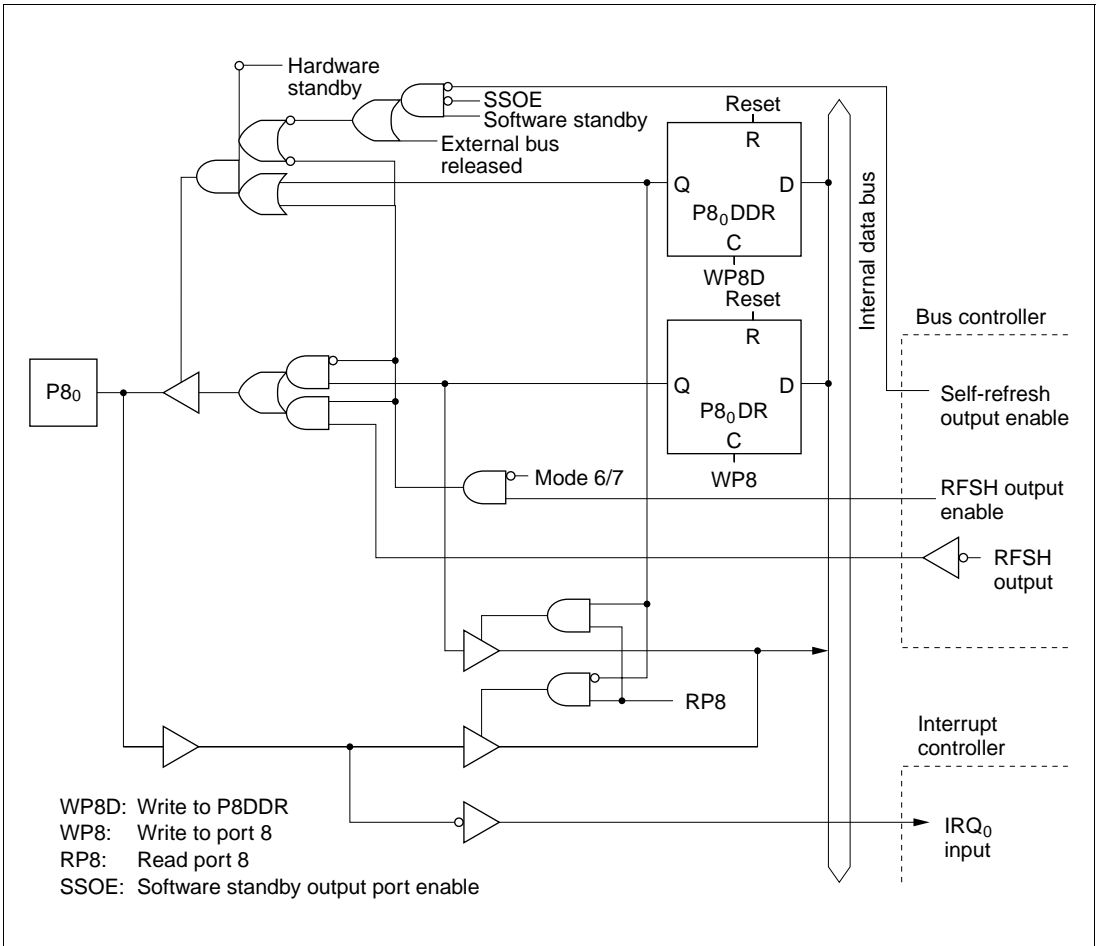
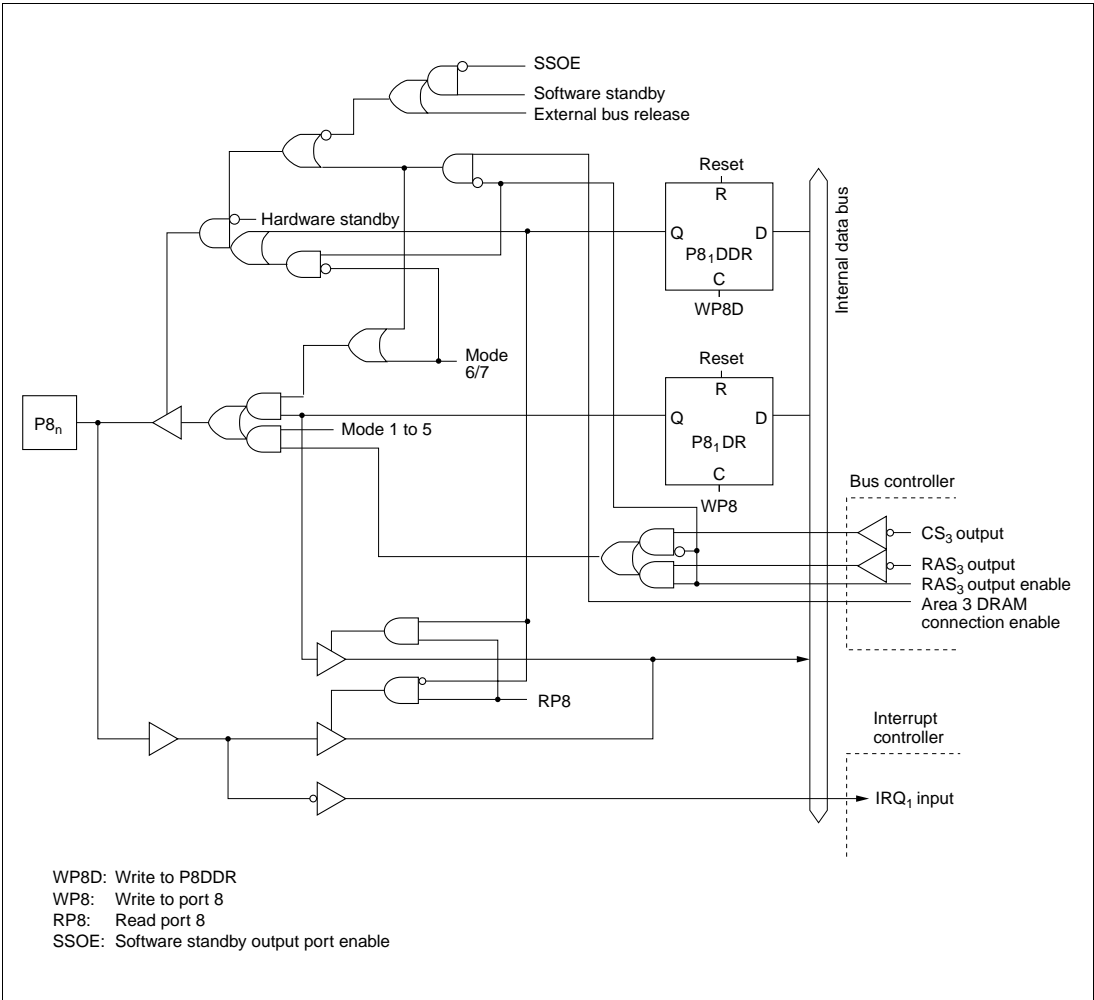
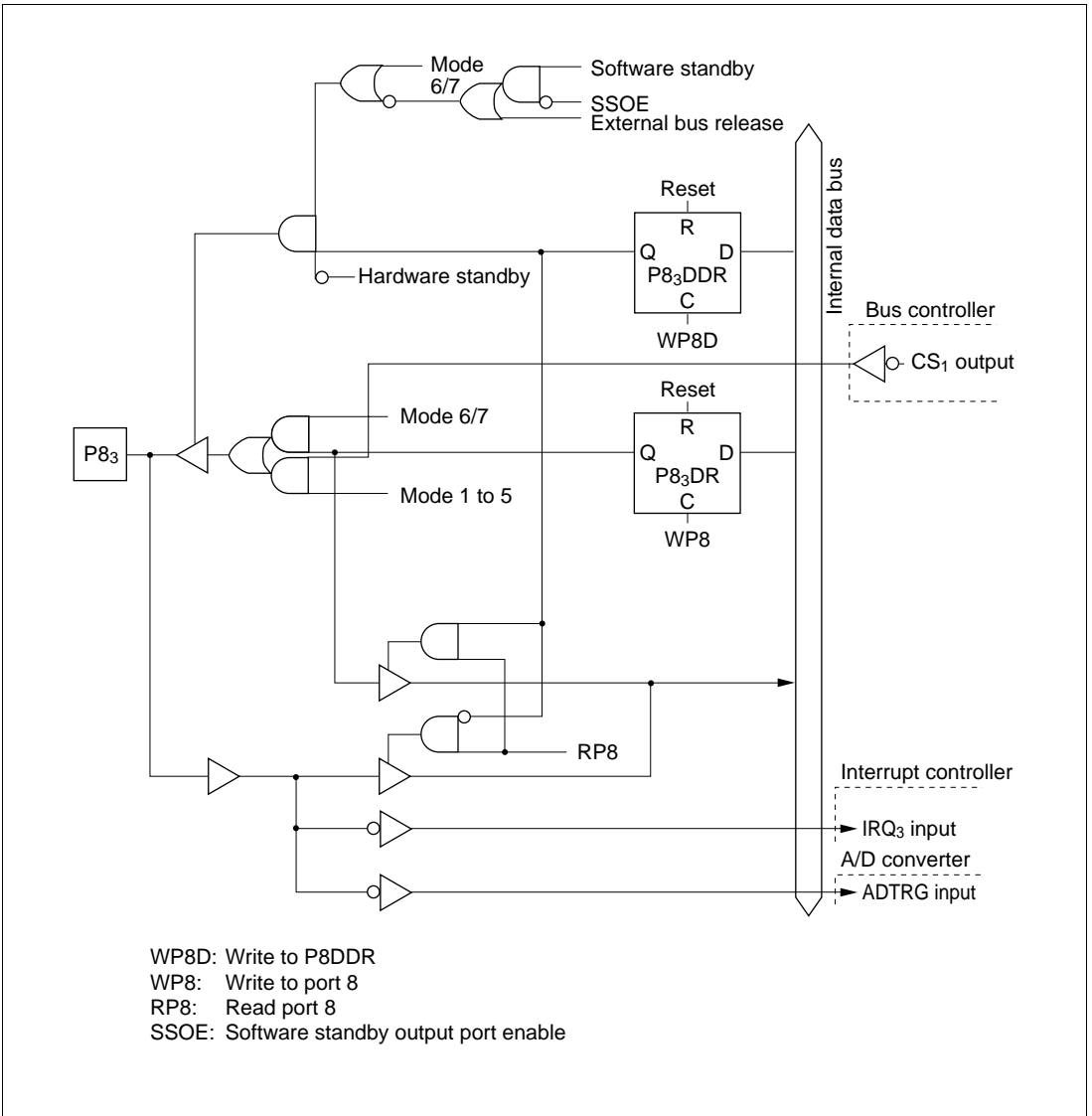


Figure C.8 (a) Port 8 Block Diagram (Pin P8<sub>0</sub>)



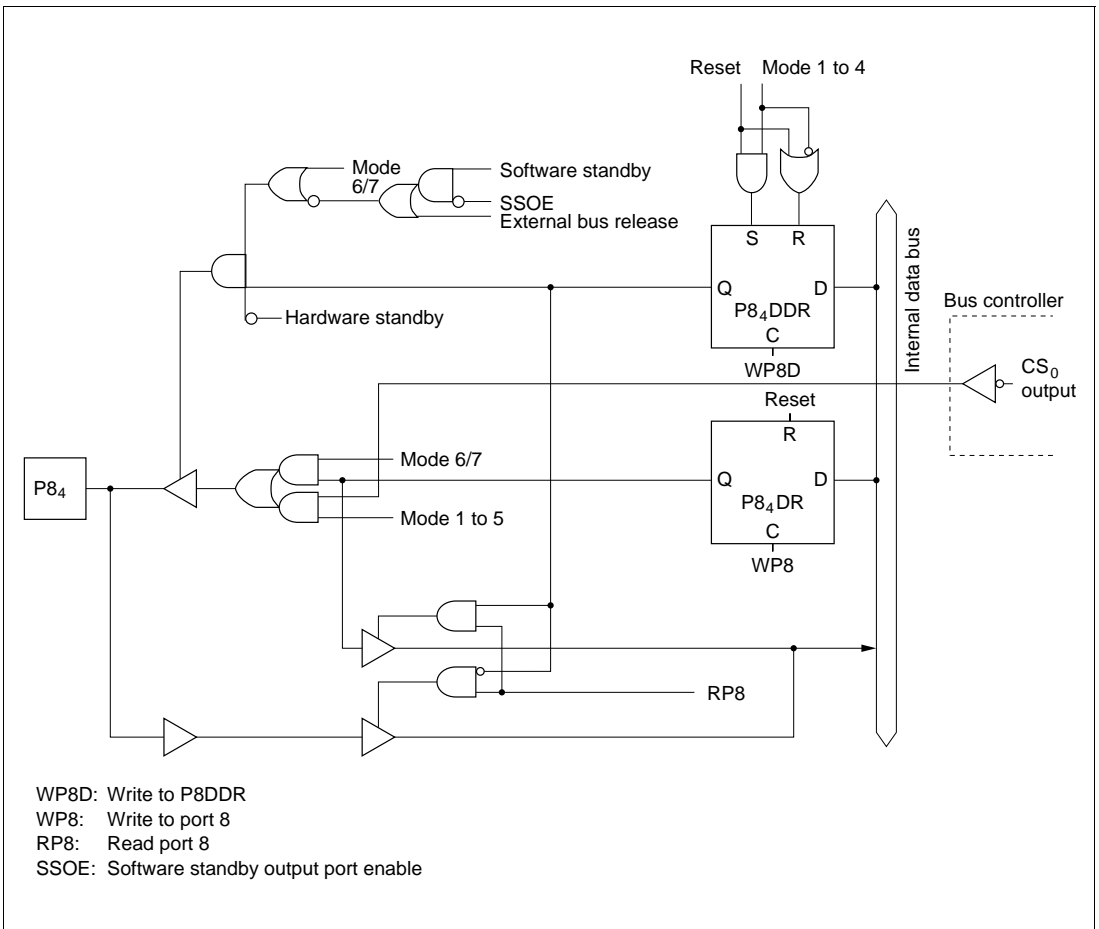
**Figure C.8 (b) Port 8 Block Diagram (Pin P8<sub>1</sub>)**





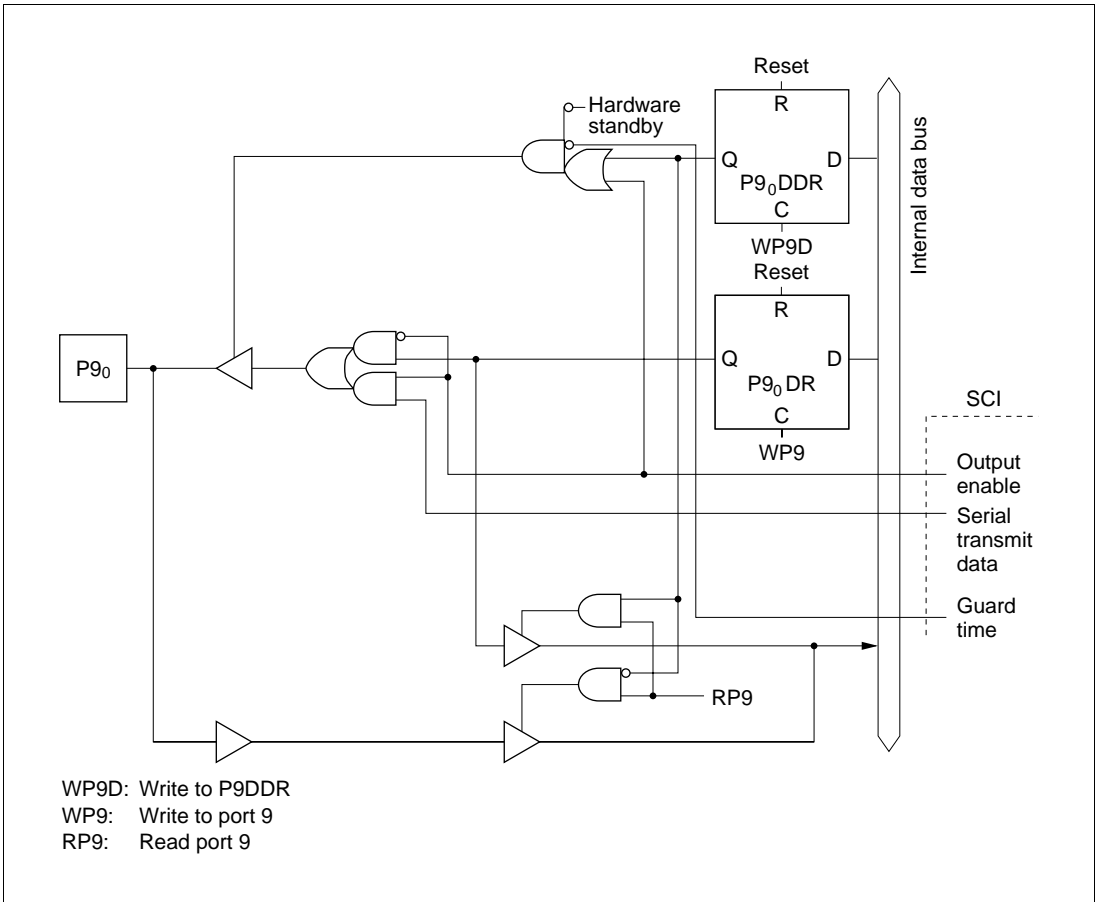
**Figure C.8 (d) Port 8 Block Diagram (Pin P83)**





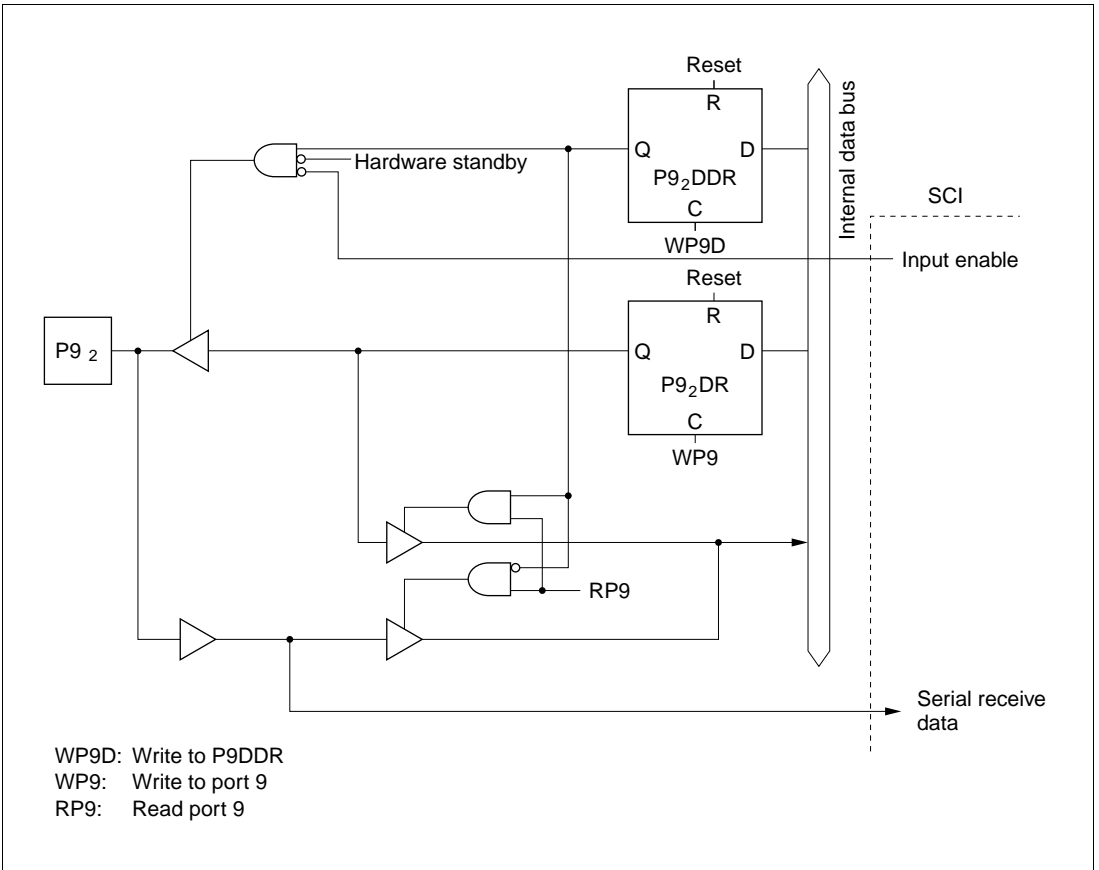
**Figure C.8 (e) Port 8 Block Diagram (Pin P84)**

## C.9 Port 9 Block Diagrams



**Figure C.9 (a) Port 9 Block Diagram (Pin P90)**

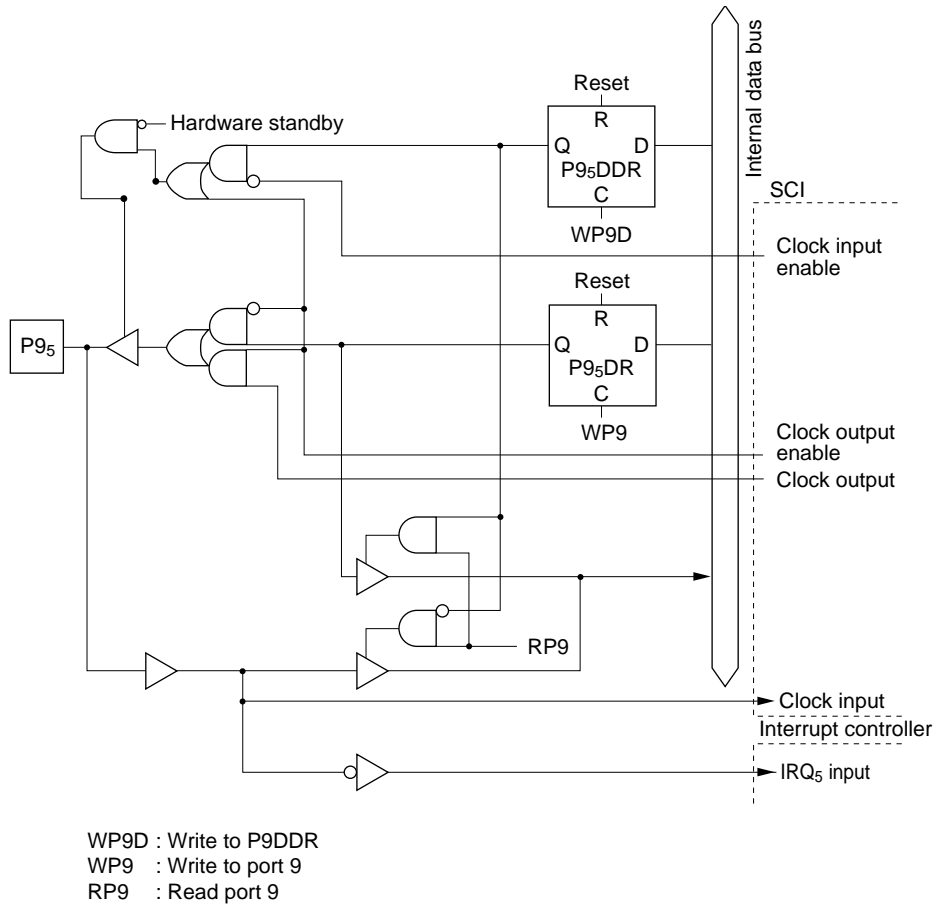




**Figure C.9 (c) Port 9 Block Diagram (Pin P9<sub>2</sub>)**







**Figure C.9 (f) Port 9 Block Diagram (Pin P95)**





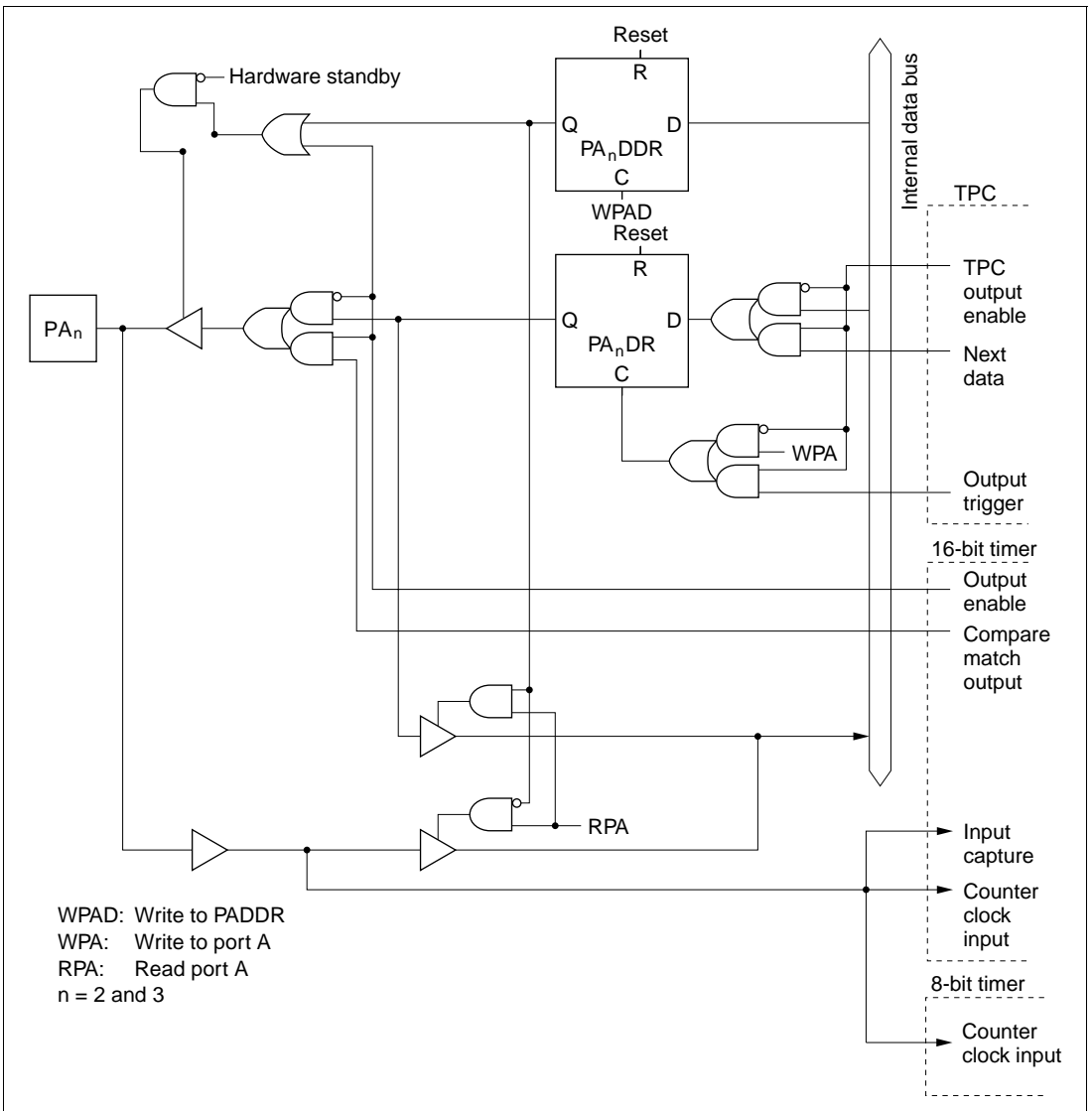
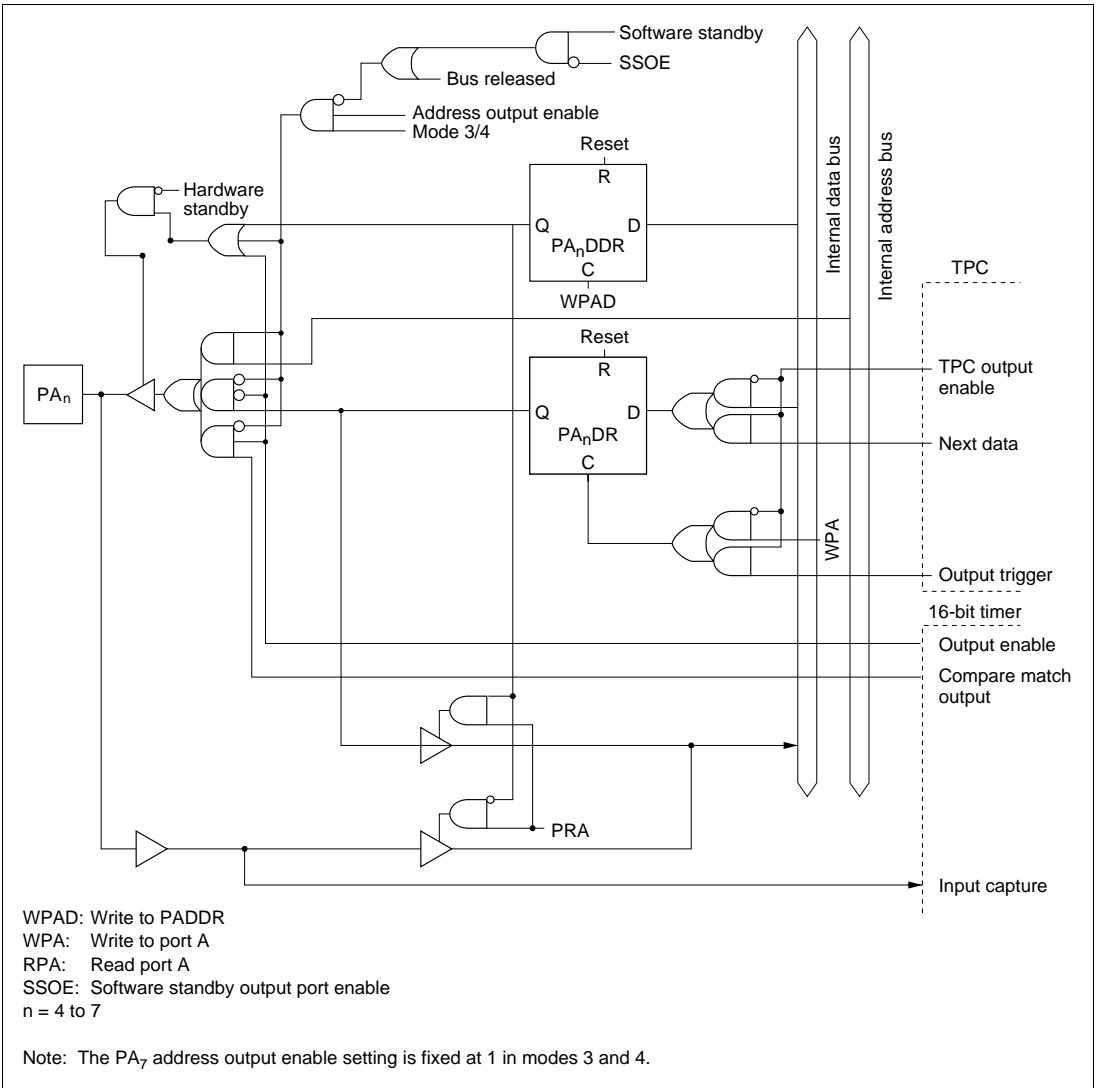


Figure C.10 (b) Port A Block Diagram (Pins PA<sub>2</sub>, PA<sub>3</sub>)



**Figure C.10 (c) Port A Block Diagram (Pins PA<sub>4</sub> to PA<sub>7</sub>)**



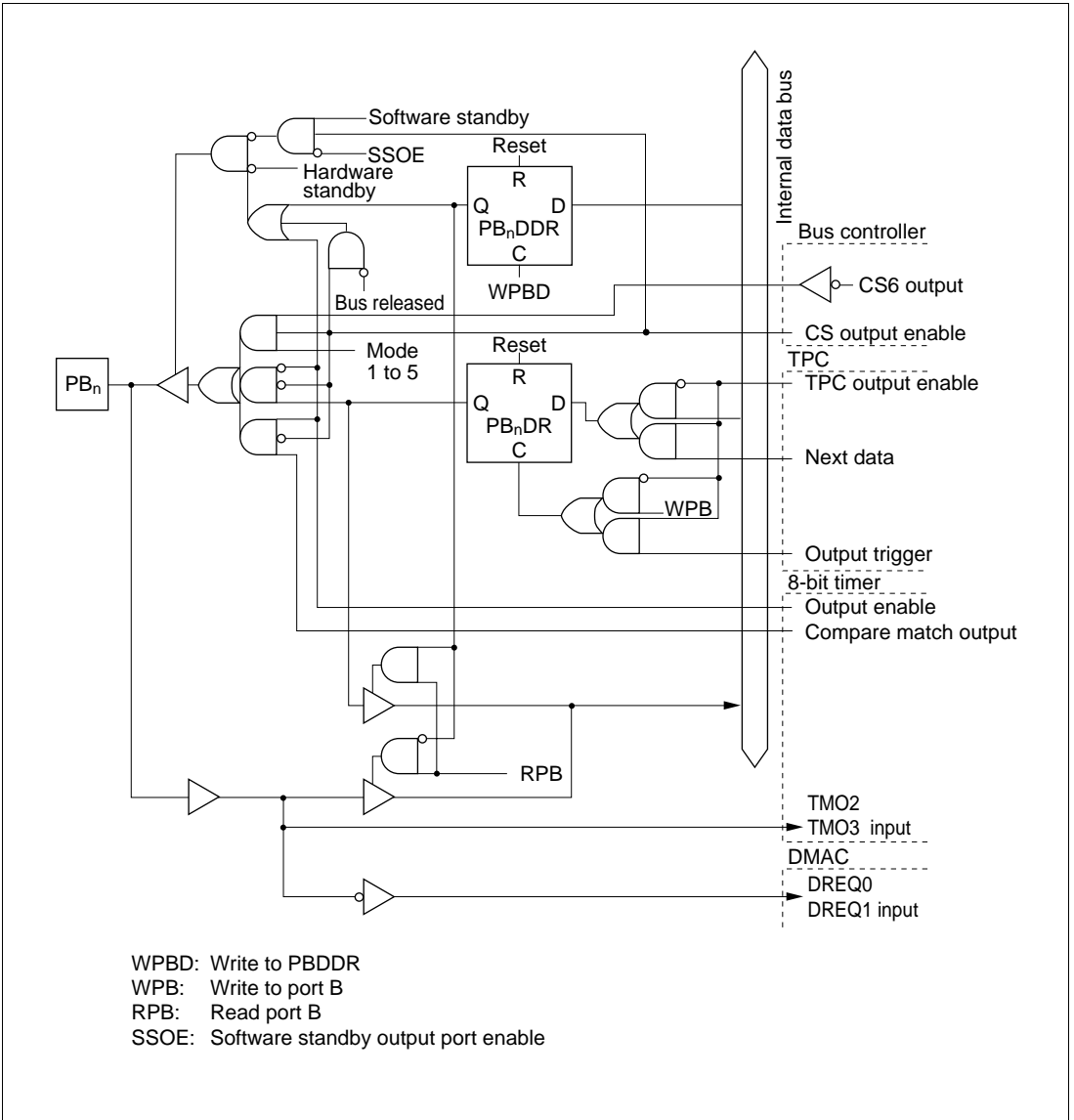


Figure C.11 (b) Port B Block Diagram (Pin PB<sub>1</sub>)

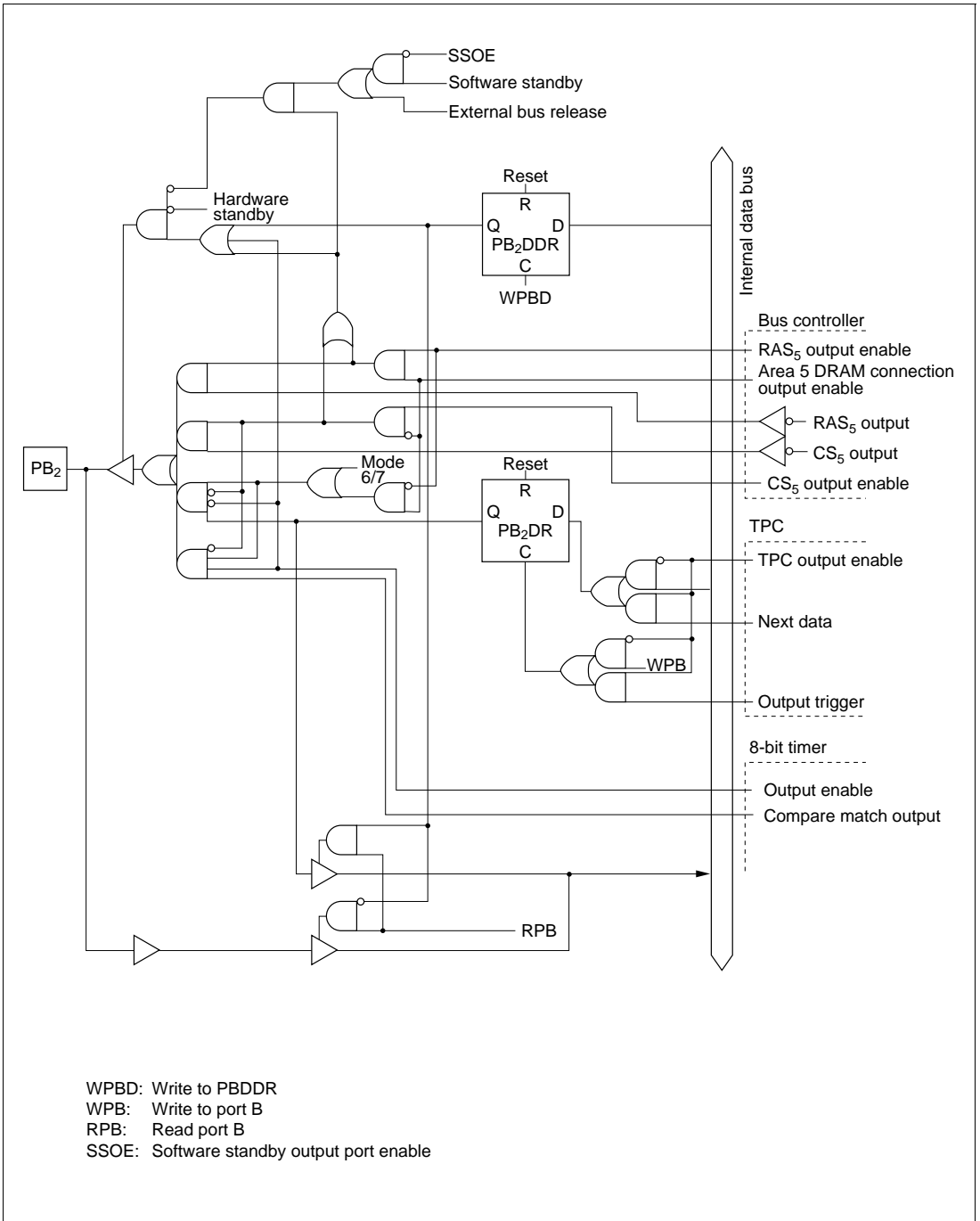
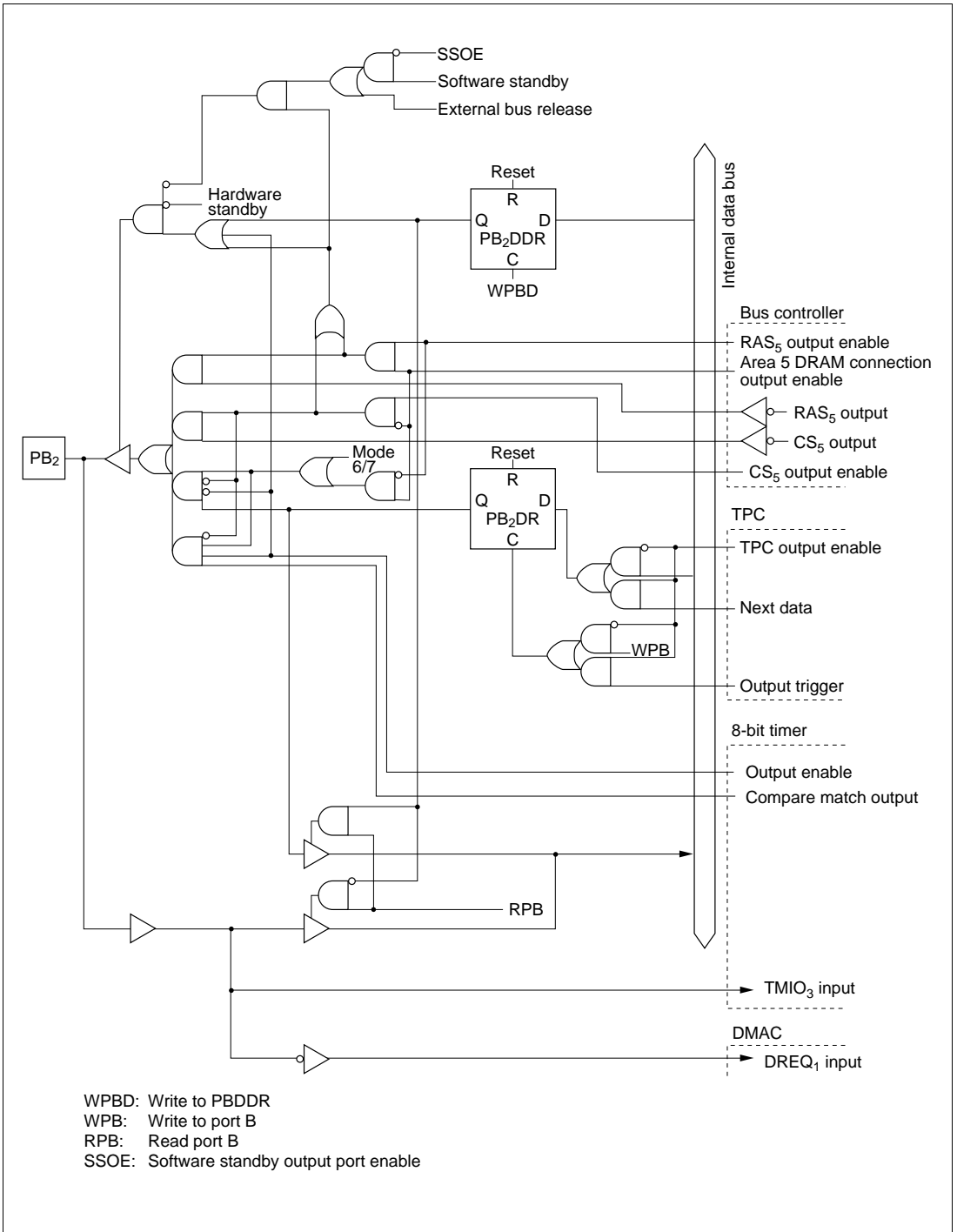
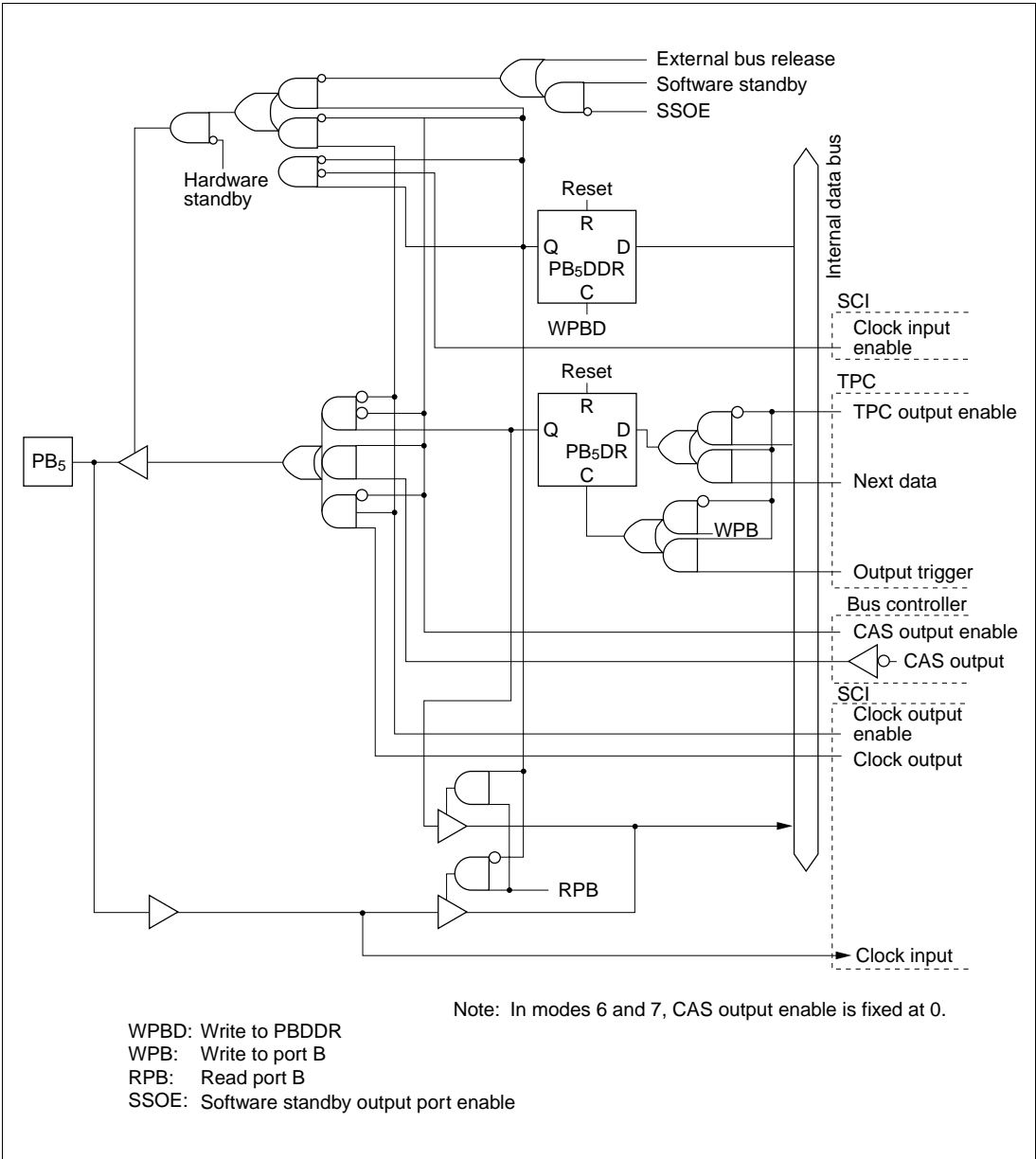


Figure C.11 (c) Port B Block Diagram (Pin PB<sub>2</sub>)



**Figure C.11 (d) Port B Block Diagram (Pin PB<sub>3</sub>)**





**Figure C.11 (f) Port B Block Diagram (Pin PB<sub>5</sub>)**







# Appendix D Pin States

## D.1 Port States in Each Mode

**Table D.1** Port States

Pin Name	Mode	Reset	Hardware Standby Mode	Software Standby Mode	Bus-Released Mode	Program Execution Mode
RESO	*17	T*17	T*17	T	T*17	T*17
P1 <sub>7</sub> to P1 <sub>0</sub>	1 to 4	L	T	(SSOE=0) T (SSOE=1) Keep	T	A <sub>7</sub> to A <sub>0</sub>
	5	T	T	(DDR = 0) Keep (DDR=1, SSOE=0) T (DDR=1, SSOE=1) Keep	T	(DDR=0) Input port (DDR=1) A <sub>7</sub> to A <sub>0</sub>
	6, 7	T	T	Keep	—	I/O port
P2 <sub>7</sub> to P2 <sub>0</sub>	1 to 4	L	T	(SSOE = 0) T (SSOE = 1) Keep	T	A <sub>15</sub> to A <sub>8</sub>
	5	T	T	(DDR = 0) Keep (DDR=1,SSOE=0) T (DDR=1,SSOE=1) Keep	T	(DDR=0) Input port (DDR=1) A <sub>15</sub> to A <sub>8</sub>
	6, 7	T	T	Keep	—	I/O port
P3 <sub>7</sub> to P3 <sub>0</sub>	1 to 5	T	T	T	T	D <sub>15</sub> to D <sub>8</sub>
	6, 7	T	T	Keep	—	I/O port
P4 <sub>7</sub> to P4 <sub>0</sub>	1, 3, 5	T	T	Keep	Keep	I/O port
	2, 4	T	T	T	T	D <sub>7</sub> to D <sub>0</sub>
	6, 7	T	T	Keep	—	I/O port

**Table D.1 Port States (cont)**

Pin Name	Mode	Reset	Hardware Standby Mode	Software Standby Mode	Bus-Released Mode	Program Execution Mode
P5 <sub>3</sub> to P5 <sub>0</sub>	1 to 4	L	T	(SSOE=0) T (SSOE=1) Keep	T	A <sub>19</sub> to A <sub>16</sub>
	5	T	T	(DDR=0) Keep (DDR=1, SSOE=0) T (DDR=1, SSOE=1) Keep	T	(DDR=0) Input port (DDR=1) A <sub>19</sub> to A <sub>16</sub>
	6, 7	T	T	Keep	—	I/O port
P6 <sub>0</sub>	1 to 5	T	T	Keep	Keep	I/O port WAIT
	6, 7	T	T	Keep	—	I/O port
P6 <sub>1</sub>	1 to 5	T	T	(BRLE=0) Keep (BRLE=1) T	T	I/O port BREQ
	6, 7	T	T	Keep	—	I/O port
P6 <sub>2</sub>	1 to 5	T	T	(BRLE=0) Keep (BRLE=1) H	L	(BRLE=0) I/O port (BRLE=1) BACK
	6, 7	T	T	Keep	—	I/O port
P6 <sub>6</sub> to P6 <sub>3</sub>	1 to 5	H	T	(SSOE=0) T (SSOE=1) H	T	$\overline{AS}$ , $\overline{RD}$ , HWR, LWR
	6, 7	T	T	Keep	—	I/O port
P6 <sub>7</sub>	1 to 7	Clock output	T	(PSTOP=0) H (PSTOP=1) Keep	(PSTOP=0) $\phi$ (PSTOP=1) Keep	(PSTOP=0) $\phi$ (PSTOP=1) Input port
P7 <sub>7</sub> to P7 <sub>0</sub>	1 to 7	T	T	T	T	Input port

**Table D.1 Port States (cont)**

Pin Name	Mode	Reset	Hardware Standby Mode	Software Standby Mode	Bus-Released Mode	Program Execution Mode
P8 <sub>0</sub>	1 to 5	T	T	When DRAM space is not selected*1 (RFSHE=0) Keep (RFSHE=1) Illegal setting	When DRAM space is selected*1 (RFSHE=0) Keep (RFSHE=1) Illegal setting	(RFSHE=0) I/O port (RFSHE=1) <u>RFSH</u>
				When DRAM space is selected*2 (RFSHE=0) Keep (RFSHE=1, SRFMD=0, SSOE=0) T (RFSHE=1, SRFMD=0, SSOE=1) H (RFSHE=1, SRFMD=1) <u>RFSH</u>	When DRAM space is selected*2 (RFSHE=0) Keep (RFSHE=1) T	
	6, 7	T	T	Keep	—	I/O port
P8 <sub>1</sub>	1 to 5	T	T	When DRAM space is selected*3 (SSOE=0) T (SSOE=1) H	When DRAM space is selected*3 T When DRAM space is selected*4 Keep	When DRAM space is selected and RAS3 is output <u>RAS<sub>3</sub></u> When DRAM space is selected and RAS3 is not output I/O port
				When DRAM space is selected*4 Keep Otherwise*5 *1 (DDR=0) T (DDR=1, SSOE=0) T (DDR=1, SSOE=1) H	Otherwise*1 (DDR=0) Keep (DDR=1) T	Otherwise I/O port Otherwise (DDR=0) Input port (DDR=1) <u>CS<sub>3</sub></u>
	6, 7	T	T	Keep	—	I/O port

**Table D.1 Port States (cont)**

Pin Name	Mode	Reset	Hardware Standby Mode	Software Standby Mode	Bus-Released Mode	Program Execution Mode
P8 <sub>2</sub>	1 to 5	T	T	RAS <sub>2</sub> output* <sup>2</sup> (SSOE=0) T (SSOE=1) H Otherwise* <sup>1</sup> (DDR=0) T (DDR=1, SSOE=0) T (DDR=1, SSOE=1) H	RAS <sub>2</sub> output* <sup>2</sup> T Otherwise* <sup>1</sup> (DDR=0) Keep (DDR=1) T	RAS <sub>2</sub> output RAS <sub>2</sub> Otherwise (DDR=0) I/O port (DDR=1) CS <sub>2</sub>
	6, 7	T	T	Keep	—	I/O port
P8 <sub>3</sub>	1 to 5	T	T	(DDR=0) T (DDR=1, SSOE=0) T (DDR=1, SSOE=1) H	(DDR=0) Keep (DDR=1) T	(DDR=0) Input port (DDR=1) CS <sub>1</sub>
	6, 7	T	T	Keep	—	I/O port
P8 <sub>4</sub>	1 to 4	H	T	(DDR=0) T (DDR=1, SSOE=0) T (DDR=1, SSOE=1) H	(DDR = 0) Keep (DDR = 1) T	(DDR = 0) Input port (DDR = 1) CS <sub>0</sub>
	5	T	T	(DDR=0) T (DDR=1, SSOE=0) T (DDR=1, SSOE=1) H	(DDR=0) Keep (DDR=1) T	(DDR=0) Input port (DDR=1) CS <sub>0</sub>
	6, 7	T	T	Keep	—	I/O port
P9 <sub>5</sub> to P9 <sub>0</sub>	1 to 7	T	T	Keep	Keep	I/O port
PA <sub>3</sub> to PA <sub>0</sub>	1 to 7	T	T	Keep	Keep	I/O port
PA <sub>6</sub> to PA <sub>4</sub>	1, 2, 6, 7	T	T	Keep	Keep	I/O port

**Table D.1 Port States (cont)**

Pin Name	Mode	Reset	Hardware Standby Mode	Software Standby Mode	Bus-Released Mode	Program Execution Mode
PA <sub>6</sub> to PA <sub>4</sub>	3 to 5	T	T	Address output* <sup>5</sup> (SSOE=0) T (SSOE=1) Keep Otherwise* <sup>6</sup> Keep	Address output* <sup>5</sup> T Otherwise* <sup>6</sup> Keep	Address output A <sub>23</sub> to A <sub>21</sub> Otherwise I/O port
PA <sub>7</sub>	1, 2	T	T	Keep	Keep	I/O port
	3, 4	L	T	(SSOE=0) T (SSOE=1) Keep	T	A <sub>20</sub>
	5	L	T	When A20E = 0 SSOE = 0 T SSOE = 1 Keep When A20E = 1 Keep	When A20E = 0 T When A20E = 1 Keep	When A20E = 0 A <sub>20</sub> When A20E = 1 I/O port
	6, 7	T	T	Keep	—	I/O port
PB <sub>1</sub> to PB <sub>0</sub>	1 to 5	T	T	CS output* <sup>7</sup> (SSOE=0) T (SSOE=1) H Otherwise* <sup>8</sup> Keep	CS output* <sup>7</sup> T Otherwise* <sup>8</sup> Keep	CS output CS <sub>7</sub> to CS <sub>6</sub> Otherwise I/O port
	6, 7	T	T	Keep	—	I/O port
PB <sub>2</sub>	1 to 5	T	T	RAS5 output* <sup>9</sup> (SSOE=0) T (SSOE=1) H CS output* <sup>10</sup> (SSOE=0) T (SSOE=1) H Otherwise* <sup>11</sup> Keep	RAS5 output* <sup>9</sup> T CS output* <sup>10</sup> T Otherwise* <sup>11</sup> Keep	RAS5 output RAS <sub>5</sub> CS output CS <sub>5</sub> Otherwise I/O port
	6, 7	T	T	Keep	—	I/O port

**Table D.1 Port States (cont)**

Pin Name	Mode	Reset	Hardware Standby Mode	Software Standby Mode	Bus-Released Mode	Program Execution Mode
PB <sub>3</sub>	1 to 5	T	T	RAS4 output* <sup>12</sup> (SSOE=0) T (SSOE=1) H CS output* <sup>13</sup> (SSOE=0) T (SSOE=1) H Otherwise* <sup>14</sup> Keep	RAS4 output* <sup>12</sup> T CS output* <sup>13</sup> T Otherwise* <sup>14</sup> Keep	RAS4 output RAS4 CS output CS4 Otherwise I/O port
	6, 7	T	T	Keep	—	I/O port
PB <sub>5</sub> to PB <sub>4</sub>	1 to 5	T	T	CAS output* <sup>15</sup> (SSOE=0) T (SSOE=1) H Otherwise* <sup>16</sup> Keep	CAS output* <sup>15</sup> T Otherwise* <sup>16</sup> Keep	CAS output UCAS, LCAS Otherwise I/O port
	6, 7	T	T	Keep	—	I/O port
PB <sub>7</sub> to PB <sub>6</sub>	1 to 7	T	T	Keep	Keep	I/O port

**Legend**

H: High

L: Low

T: High-impedance state

Keep: Input pins are in the high-impedance state; output pins maintain their previous state.

DDR: Data direction register

- Notes:
1. When bits DRAS2, DRAS1, and DRAS0 in DRCRA (DRAM control register A) are all cleared to 0.
  2. When any of bits DRAS2, DRAS1, or DRAS0 in DRCRA (DRAM control register A) is set to 1.
  3. When the setting of bits DRAS2, DRAS1, and DRAS0 in DRCRA (DRAM control register A) is 010, 100, or 101.
  4. When the setting of bits DRAS2, DRAS1, and DRAS0 in DRCRA (DRAM control register A) is other than 010, 100, 101, or 000.
  5. When bit A23E, A22E, or A21E, respectively, in BRCCR (bus release control register) is cleared to 0.
  6. When bit A23E, A22E, or A21E, respectively, in BRCCR (bus release control register) is set to 1.
  7. When bit CS7E or CS6E, respectively, in CSCR (chip select control register) is set to 1.
  8. When bit CS7E or CS6E, respectively, in CSCR (chip select control register) is cleared to 0.



9. When the setting of bits DRAS2, DRAS1, and DRAS0 in DRCRA (DRAM control register A) is 101.
10. When the setting of bits DRAS2, DRAS1, and DRAS0 in DRCRA (DRAM control register A) is other than 101, and bit CS5E in CSCR (chip select control register) is set to 1.
11. When the setting of bits DRAS2, DRAS1, and DRAS0 in DRCRA (DRAM control register A) is other than 101, and bit CS5E in CSCR (chip select control register) is cleared to 0.
12. When the setting of bits DRAS2, DRAS1, and DRAS0 in DRCRA (DRAM control register A) is 100, 101, or 110.
13. When the setting of bits DRAS2, DRAS1, and DRAS0 in DRCRA (DRAM control register A) is other than 100, 101, or 110, and bit CS4E in CSCR (chip select control register) is set to 1.
14. When the setting of bits DRAS2, DRAS1, and DRAS0 in DRCRA (DRAM control register A) is other than 100, 101, or 110, and bit CS4E in CSCR (chip select control register) is cleared to 0.
15. When any of bits DRAS2, DRAS1, or DRAS0 in DRCRA (DRAM control register A) is set to 1, and bit CSEL in DRCRB (DRAM control register B) is cleared to 0.
16. When any of bits DRAS2, DRAS1, or DRAS0 in DRCRA (DRAM control register A) is set to 1, and bit CSEL in DRCRB (DRAM control register B) is set to 1; or, when bits DRAS2, DRAS1, and DRAS0 are all cleared to 0.
17.  $\overline{\text{RESO}}$  output is a mask ROM version function. A low level is output only in the case of a reset due to WDT overflow. There is no bus-released state in modes 6 and 7.

## D.2 Pin States at Reset

**Modes 1 and 2:** Figure D.1 is a timing diagram for the case in which  $\overline{\text{RES}}$  goes low during an external memory access in mode 1 or 2. As soon as  $\overline{\text{RES}}$  goes low, all ports are initialized to the input state.  $\overline{\text{AS}}$ ,  $\overline{\text{RD}}$ ,  $\overline{\text{HWR}}$ ,  $\overline{\text{LWR}}$ , and  $\overline{\text{CS}}_0$  go high, and  $\text{D}_{15}$  to  $\text{D}_0$  go to the high-impedance state. The address bus is initialized to the low output level  $2.5 \phi$  clock cycles after the low level of  $\overline{\text{RES}}$  is sampled. Clock pin  $\text{P6}_7/\phi$  goes to the output state at the next rise of  $\phi$  after  $\overline{\text{RES}}$  goes low.

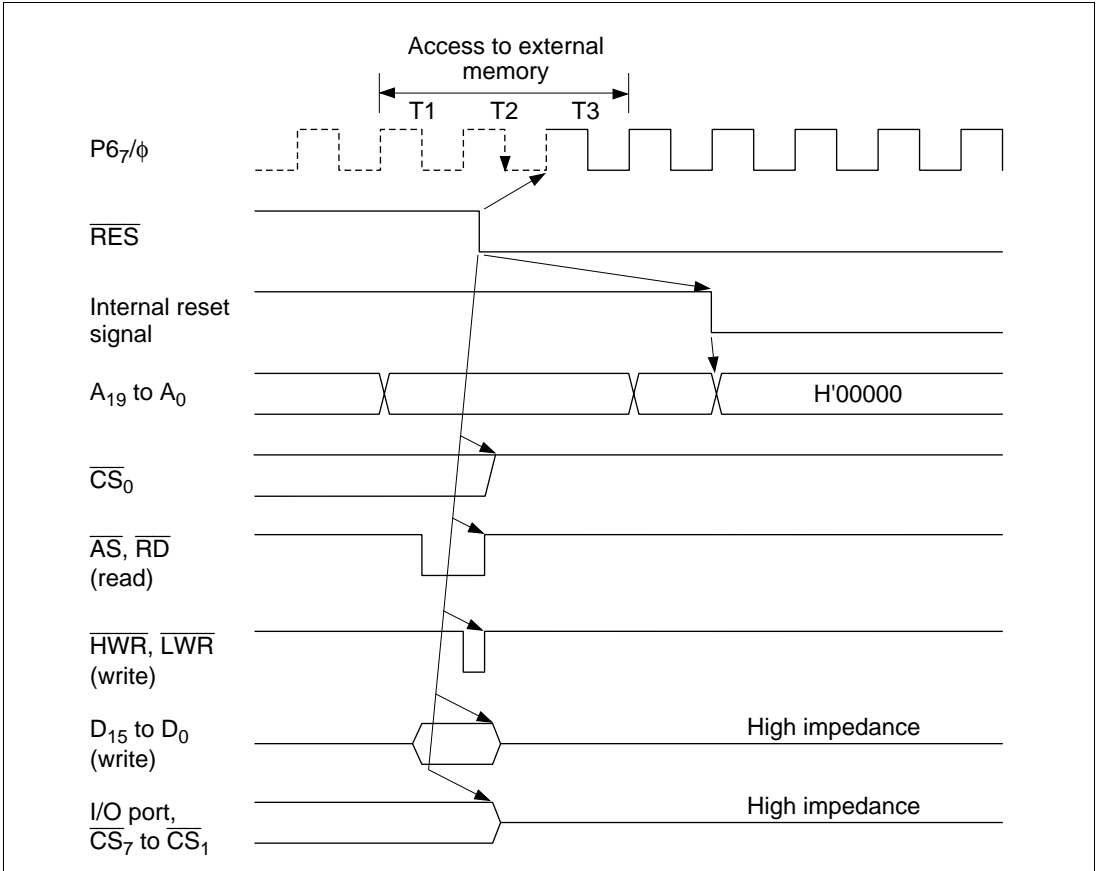
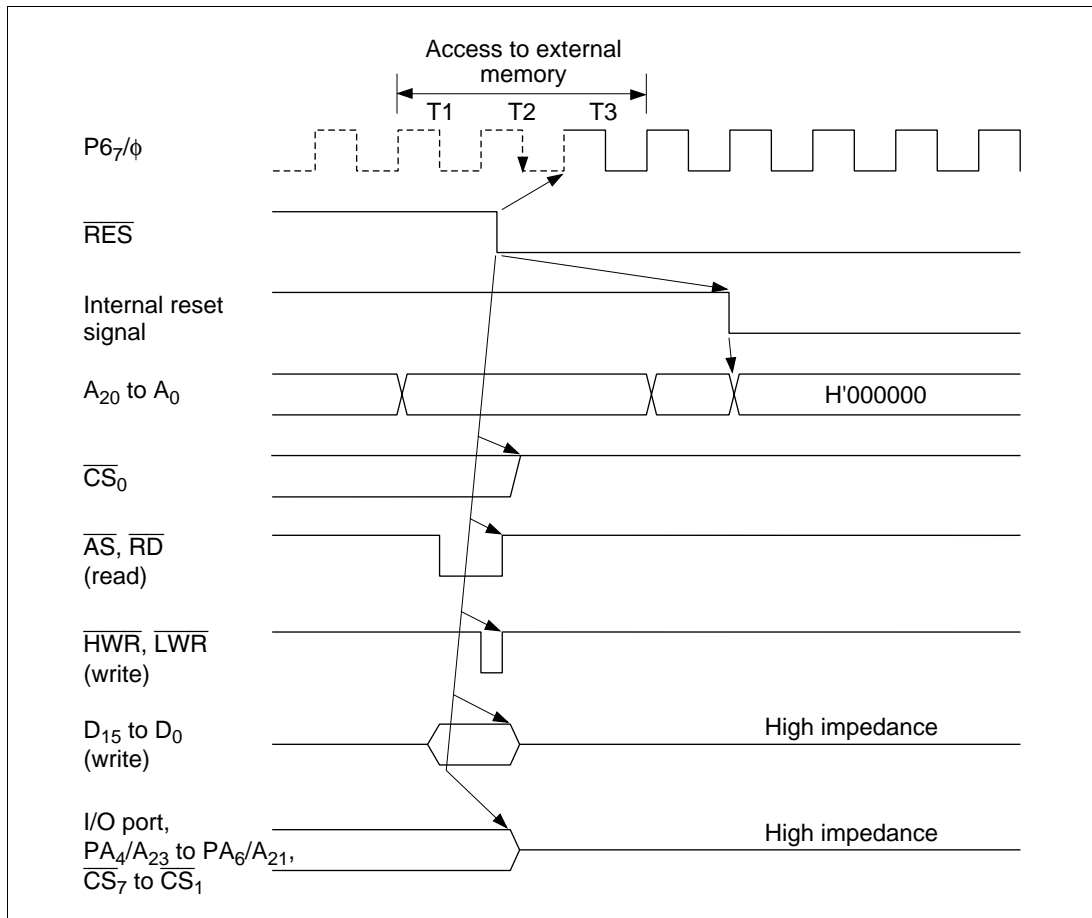


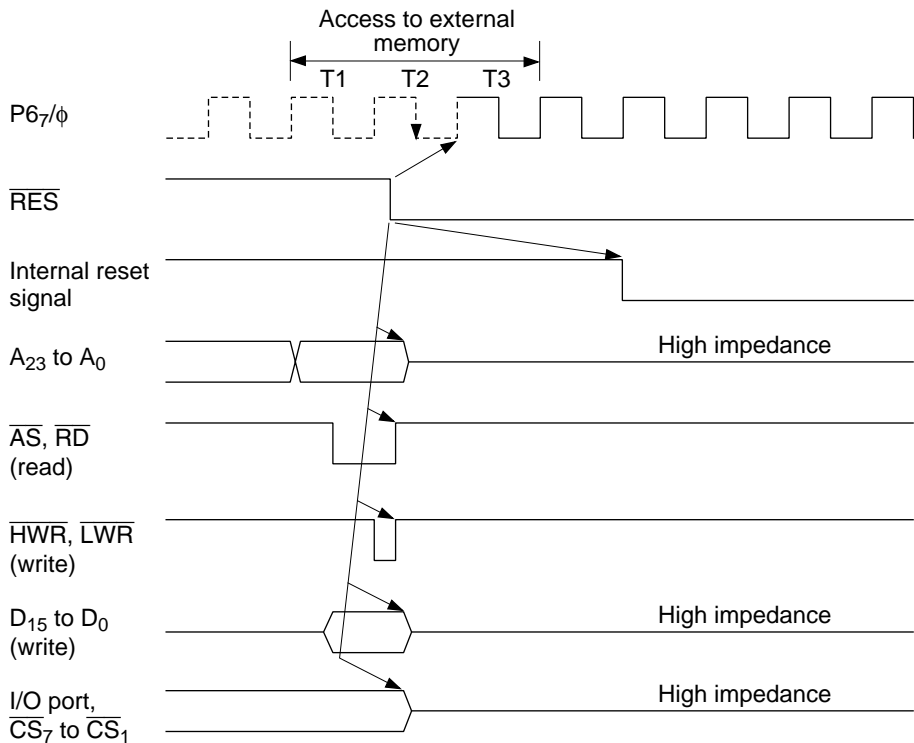
Figure D.1 Reset during Memory Access (Modes 1 and 2)

**Modes 3 and 4:** Figure D.2 is a timing diagram for the case in which  $\overline{\text{RES}}$  goes low during an external memory access in mode 3 or 4. As soon as  $\overline{\text{RES}}$  goes low, all ports are initialized to the input state.  $\overline{\text{AS}}$ ,  $\overline{\text{RD}}$ ,  $\overline{\text{HWR}}$ ,  $\overline{\text{LWR}}$ , and  $\overline{\text{CS}}_0$  go high, and  $\text{D}_{15}$  to  $\text{D}_0$  go to the high-impedance state. The address bus is initialized to the low output level 2.5  $\phi$  clock cycles after the low level of  $\overline{\text{RES}}$  is sampled. However, when  $\text{PA}_4$  to  $\text{PA}_6$  are used as address bus pins, or when  $\text{P8}_3$  to  $\text{P8}_1$  and  $\text{PB}_0$  to  $\text{PB}_3$  are used as CS output pins, they go to the high-impedance state at the same time as  $\overline{\text{RES}}$  goes low. Clock pin  $\text{P6}_7/\phi$  goes to the output state at the next rise of  $\phi$  after  $\overline{\text{RES}}$  goes low.



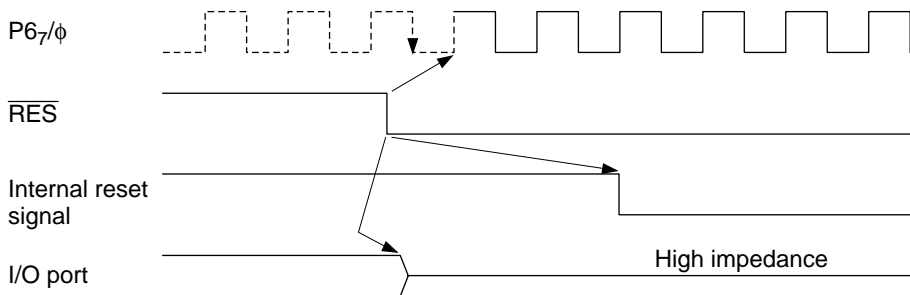
**Figure D.2 Reset during Memory Access (Modes 3 and 4)**

**Mode 5:** Figure D.3 is a timing diagram for the case in which  $\overline{\text{RES}}$  goes low during an external memory access in mode 5. As soon as  $\overline{\text{RES}}$  goes low, all ports are initialized to the input state.  $\overline{\text{AS}}$ ,  $\overline{\text{RD}}$ ,  $\overline{\text{HWR}}$ , and  $\overline{\text{LWR}}$  go high, and the address bus and  $\text{D}_{15}$  to  $\text{D}_0$  go to the high-impedance state. Clock pin  $\text{P6}_7/\phi$  goes to the output state at the next rise of  $\phi$  after  $\overline{\text{RES}}$  goes low.



**Figure D.3 Reset during Memory Access (Mode 5)**

**Modes 6 and 7:** Figure D.4 is a timing diagram for the case in which  $\overline{\text{RES}}$  goes low during an operation in mode 6 or 7. As soon as  $\overline{\text{RES}}$  goes low, all ports are initialized to the input state. Clock pin P6<sub>7</sub>/φ goes to the output state at the next rise of φ after  $\overline{\text{RES}}$  goes low.

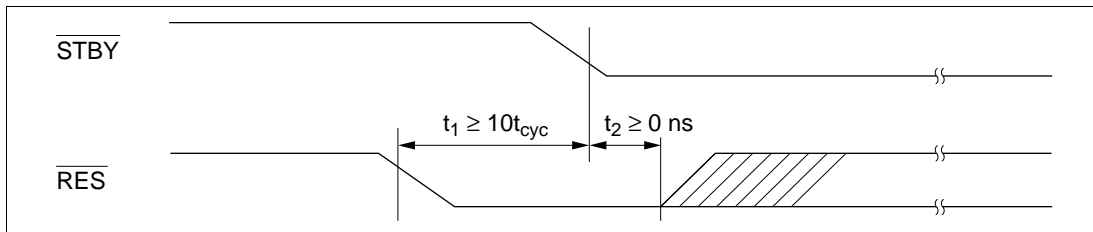


**Figure D.4 Reset during Operation (Modes 6 and 7)**

# Appendix E Timing of Transition to and Recovery from Hardware Standby Mode

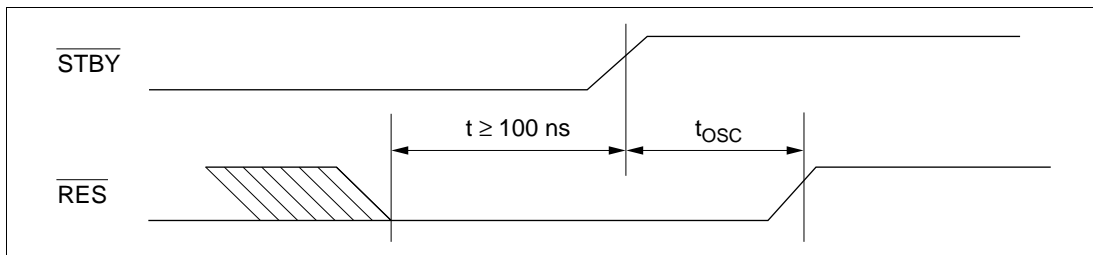
## Timing of Transition to Hardware Standby Mode

1. To retain RAM contents with the RAME bit set to 1 in SYSCR, drive the  $\overline{\text{RES}}$  signal low 10 system clock cycles before the  $\overline{\text{STBY}}$  signal goes low, as shown below.  $\overline{\text{RES}}$  must remain low until  $\overline{\text{STBY}}$  goes low (minimum delay from  $\overline{\text{STBY}}$  low to  $\overline{\text{RES}}$  high: 0 ns).



2. To retain RAM contents with the RAME bit cleared to 0 in SYSCR,  $\overline{\text{RES}}$  does not have to be driven low as in (1).

**Timing of Recovery from Hardware Standby Mode:** Drive the  $\overline{\text{RES}}$  signal low approximately 100 ns before  $\overline{\text{STBY}}$  goes high.



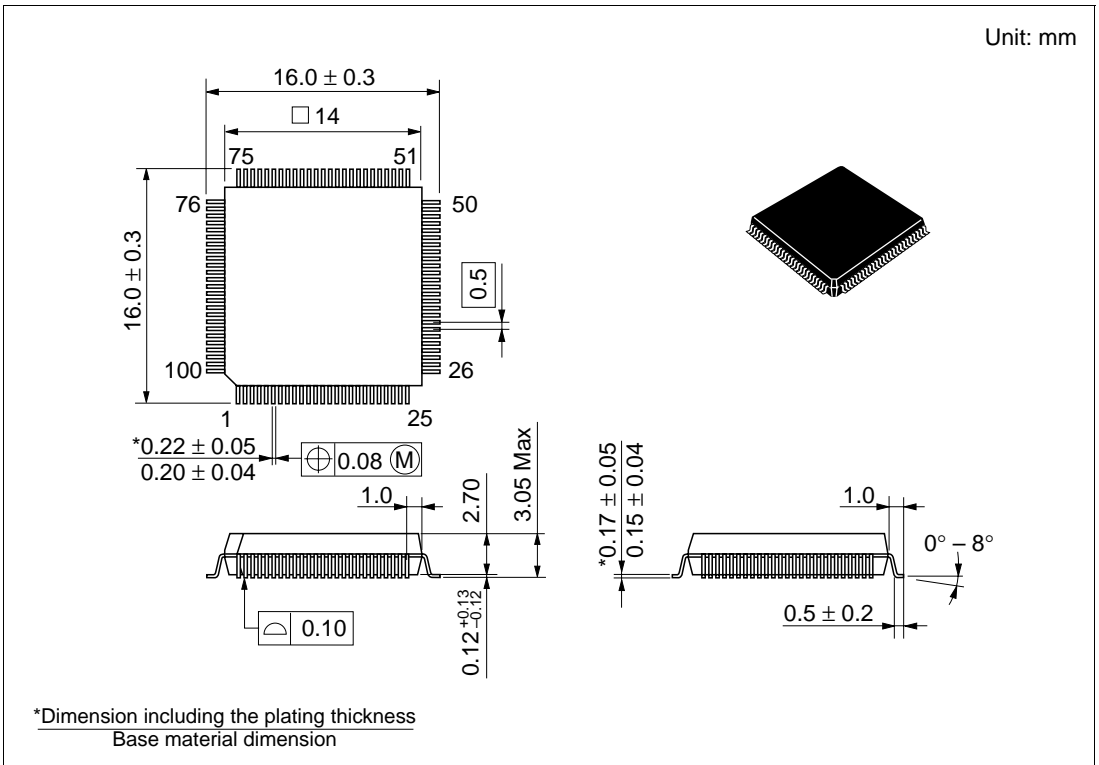
# Appendix F Product Code Lineup

Product Type		Product Code	Mark Code	Package (Hitachi Package Code)	
H8/3067	On-chip flash memory	5 V	HD64F3067F	HD64F3067F	100-pin QFP (FP-100B)
			HD64F3067TE	HD64F3067TE	100-pin TQFP (TFP-100B)
			HD64F3067FP	HD64F3067FP	100-pin QFP (FP-100A)
		5 VR	HD64F3067RF	HD64F3067RF	100-pin QFP (FP-100B)
			HD64F3067RTE	HD64F3067RTE	100-pin TQFP (TFP-100B)
			HD64F3067RFP	HD64F3067RFP	100-pin QFP (FP-100A)
	3 VR		HD64F3067RVF	HD64F3067RVF	100-pin QFP (FP-100B)
			HD64F3067RVTE	HD64F3067RVTE	100-pin TQFP (TFP-100B)
			HD64F3067RVFP	HD64F3067RVFP	100-pin QFP (FP-100A)
	On-chip mask ROM	5 V	HD6433067F	HD6433067(***)F	100-pin QFP (FP-100B)
			HD6433067TE	HD6433067(***)TE	100-pin TQFP (TFP-100B)
			HD6433067FP	HD6433067(***)FP	100-pin QFP (FP-100A)
3 V		HD6433067VF	HD6433067(***)VF	100-pin QFP (FP-100B)	
		HD6433067VTE	HD6433067(***)VTE	100-pin TQFP (TFP-100B)	
		HD6433067VFP	HD6433067(***)VFP	100-pin QFP (FP-100A)	
H8/3066	On-chip mask ROM	5 V	HD6433066F	HD6433066(***)F	100-pin QFP (FP-100B)
			HD6433066TE	HD6433066(***)TE	100-pin TQFP (TFP-100B)
			HD6433066FP	HD6433066(***)FP	100-pin QFP (FP-100A)
	3 V	HD6433066VF	HD6433066(***)VF	100-pin QFP (FP-100B)	
		HD6433066VTE	HD6433066(***)VTE	100-pin TQFP (TFP-100B)	
		HD6433066VFP	HD6433066(***)VFP	100-pin QFP (FP-100A)	
H8/3065	On-chip mask ROM	5 V	HD6433065F	HD6433065(***)F	100-pin QFP (FP-100B)
			HD6433065TE	HD6433065(***)TE	100-pin TQFP (TFP-100B)
			HD6433065FP	HD6433065(***)FP	100-pin QFP (FP-100A)
	3 V	HD6433065VF	HD6433065(***)VF	100-pin QFP (FP-100B)	
		HD6433065VTE	HD6433065(***)VTE	100-pin TQFP (TFP-100B)	
		HD6433065VFP	HD6433065(***)VFP	100-pin QFP (FP-100A)	

Note: For mask ROM versions, (\*\*\*) is the ROM code.

# Appendix G Package Dimensions

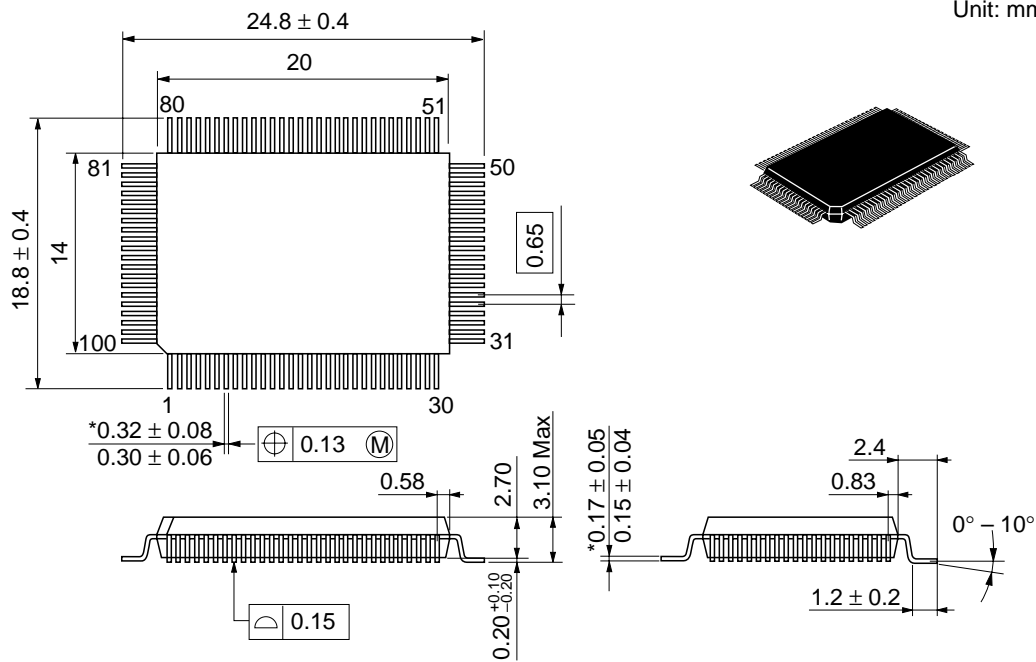
Figures G.1 show the FP-100B package dimensions of the H8/3067 Series. Figure G.2 shows the TFP-100B package dimensions. Figure G.3 shows the FP-100A package dimensions.



**Figure G.1 Package Dimensions (FP-100B)**







\*Dimension including the plating thickness  
Base material dimension

Figure G.3 Package Dimensions (FP-100A)

# Appendix H Comparison of H8/300H Series Product Specifications

## H.1 Differences between H8/3067 and H8/3062 Series, H8/3048 Series, H8/3007 and H8/3006, and H8/3002

Item		H8/3067, H8/3062 Series	H8/3048 Series	H8/3006, 3007	H8/3002	
1	Operating mode	Mode 5 16 MB ROM enabled expanded mode	1 MB ROM enabled expanded mode			
		Mode 6 64 KB single-chip mode	16 MB ROM enabled expanded mode			
2	Interrupt controller	Internal interrupt sources 36 (H8/3067) 27 (H8/3062)	30	36	30	
3	Bus controller	Burst ROM interface Yes (H8/3067) No (H8/3062)	No	Yes	No	
		Idle cycle insertion function	Yes	No	Yes	No
		Wait mode	2 modes	4 modes	2 modes	4 modes
		Wait state number setting	Per area	Common to all areas	Per area	Common to all areas
		Address output method	Choice of address update mode (mask ROM and flash memory R versions only)	Fixed	Fixed	Fixed
4	DRAM interface	Connectable areas Area 2/3/4/5 (H8/3067 only)	Area 3	Area 2/3/4/5	Area 3	
		Precharge cycle insertion function	Yes (H8/3067 only)	No	Yes	No
		Fast page mode	Yes (H8/3067 only)	No	Yes	No
		Address shift amount	8 bit/9 bit/10 bit (H8/3067 only)	8 bit/9 bit	8 bit/9 bit/10 bit	8 bit/9 bit

Item		H8/3067, H8/3062 Series		H8/3048 Series	H8/3006, 3007		H8/3002
5	Timer functions	16-bit timers	8-bit timers	ITU	16-bit timers	8-bit timers	ITU
	Number of channels	16 bits × 3	8 bits × 4 (16 bits × 2)	16 bits × 5	16 bits × 3	8 bits × 4 (16 bits × 2)	16 bits × 5
	Pulse output	6 pins	4 pins (2 pins)	12 pins	6 pins	4 pins (2 pins)	12 pins
	Input capture	6	2	10	6	2	10
	External clock	4 systems (selectable)	4 systems (fixed)	4 systems (selectable)	4 systems (selectable)	4 systems (fixed)	4 systems (selectable)
	Internal clock	$\phi$ , $\phi/2$ , $\phi/4$ , $\phi/8$	$\phi/8$ , $\phi/64$ , $\phi/8192$	$\phi$ , $\phi/2$ , $\phi/4$ , $\phi/8$	$\phi$ , $\phi/2$ , $\phi/4$ , $\phi/8$	$\phi/8$ , $\phi/64$ , $\phi/8192$	$\phi$ , $\phi/2$ , $\phi/4$ , $\phi/8$
	Complementary PWM function	No	No	Yes	No	No	Yes
	Reset-synchronous PWM function	No	No	Yes	No	No	Yes
	Buffer operation	No	No	Yes	No	No	Yes
	Output initialization function	Yes	No	No	Yes	No	No
	PWM output	3	4 (2)	5	3	4 (2)	5
	DMAC activation	3 channels (H8/3067 only)	No	4 channels	3 channels	No	4 channels
	A/D conversion activation	No	Yes	No	No	Yes	No
Interrupt sources	3 sources × 3	8 sources	3 sources × 5	3 sources × 3	8 sources	3 sources × 5	
6	TPC	Time base	3 kinds, 16-bit timer base	4 kinds, ITU base	3 kinds, 16-bit timer base	4 kinds, ITU base	
7	WDT	Reset signal external output function	Yes (except products with on-chip flash memory)	Yes	Yes	Yes	Yes
8	SCI	Number of channels	3 channels (H8/3067) 2 channels (H8/3062)	2 channels	3 channels		2 channels
		Smart card interface	Supported on all channels	Supported on SCIO only	Supported on all channels		No

Item		H8/3067, H8/3062 Series	H8/3048 Series	H8/3006, 3007	H8/3002	
9	A/D converter	Conversion start trigger input	External trigger/8-bit timer compare match	External trigger	External trigger/8-bit timer compare match	External trigger
10	Pin control	$\phi$ pin	$\phi$ /input port multiplexing	$\phi$ output only	$\phi$ /input port multiplexing	$\phi$ output only
		A <sub>20</sub> in 16 MB ROM enabled expanded mode	A <sub>20</sub> / I/O port multiplexing	A <sub>20</sub> output		
		Address bus, $\overline{AS}$ , $\overline{RD}$ , $\overline{HWR}$ , $\overline{LWR}$ , $\overline{CS}_7$ – $\overline{CS}_0$ , $\overline{RFSH}$ in software standby state	High-level output/high-impedance selectable (RFSH: H8/3067 only)	High-level output (except $\overline{CS}_0$ )	High-level output/high-impedance selectable	High-level output (except $\overline{CS}_0$ )
		$\overline{CS}_7$ – $\overline{CS}_0$ in bus-released state	High-impedance	High-level output	High-impedance	High-level output
11	Flash memory functions	Program/erase voltage	12 V application unnecessary. Single-power-supply programming.	12 V application from off-chip		
		Block divisions	8 blocks	16 blocks		

## H.2 Comparison of Pin Functions of 100-Pin Package Products (FP-100B, TFP-100B)

Table H.1 Pin Arrangement of Each Product (FP-100B, TFP-100B)

Pin No.	On-chip-ROM Products				ROMless Products	
	H8/3067 Series	H8/3062 Series	H8/3048 Series	H8/3042 Series	H8/3006, 3007	H8/3002
1	Vcc	Vcc	Vcc	Vcc	Vcc	Vcc
	PB <sub>i</sub> CS <sub>i</sub>	PB <sub>i</sub> CS <sub>i</sub>	PB <sub>i</sub> TIC	PB <sub>i</sub> TIC	PB <sub>i</sub> CS <sub>i</sub>	PB <sub>0</sub> /TP <sub>8</sub> / TIOCA <sub>3</sub>
	PB <sub>i</sub> DR	PB <sub>i</sub> CS <sub>i</sub>	PB <sub>i</sub> TIC	PB <sub>i</sub> TIC	PB <sub>i</sub> DR	PB <sub>1</sub> /TP <sub>9</sub> / TIOCB <sub>3</sub>
	PB <sub>i</sub> CS <sub>i</sub>	PB <sub>i</sub> CS <sub>i</sub>	PB <sub>i</sub> TIC	PB <sub>i</sub> TIC	PB <sub>i</sub> CS <sub>i</sub>	PB <sub>2</sub> /TP <sub>10</sub> / TIOCA <sub>4</sub>
	PB <sub>i</sub> TM CS <sub>i</sub>	PB <sub>i</sub> TM	PB <sub>i</sub> TIC	PB <sub>i</sub> TIC	PB <sub>i</sub> TM CS <sub>i</sub>	PB <sub>3</sub> /TP <sub>11</sub> / TIOCB <sub>4</sub>
	PB <sub>i</sub> UC	PB <sub>i</sub>	PB <sub>i</sub> TO <sub>i</sub>	PB <sub>i</sub> TO <sub>i</sub>	PB <sub>i</sub> UC	PB <sub>4</sub> /TP <sub>12</sub> / TOCXA <sub>4</sub>
	PB <sub>i</sub> LC <sub>i</sub>	PB <sub>i</sub>	PB <sub>i</sub> TO <sub>i</sub>	PB <sub>i</sub> TO <sub>i</sub>	PB <sub>i</sub> LC <sub>i</sub>	PB <sub>5</sub> /TP <sub>13</sub> / TOCXB <sub>4</sub>
	PB <sub>i</sub>	PB <sub>i</sub>	PB <sub>i</sub> DR	PB <sub>i</sub> DR	PB <sub>i</sub>	PB <sub>6</sub> /TP <sub>14</sub> / DREQ <sub>0</sub>
	PB <sub>i</sub>	PB <sub>i</sub>	PB <sub>i</sub> DR	PB <sub>i</sub> DR	PB <sub>i</sub>	PB <sub>7</sub> /TP <sub>15</sub> / DREQ <sub>1</sub> /ADTRG
	RE <sub>i</sub>	RE <sub>i</sub>	RE <sub>i</sub>	RE <sub>i</sub>	RE <sub>i</sub>	RESO
11	Vss	Vss	Vss	Vss	Vss	Vss
12	P9 <sub>0</sub> /TxD <sub>0</sub>	P9 <sub>0</sub> /TxD <sub>0</sub>	P9 <sub>0</sub> /TxD <sub>0</sub>	P9 <sub>0</sub> /TxD <sub>0</sub>	P9 <sub>0</sub> /TxD <sub>0</sub>	P9 <sub>0</sub> /TxD <sub>0</sub>
13	P9 <sub>1</sub> /TxD <sub>1</sub>	P9 <sub>1</sub> /TxD <sub>1</sub>	P9 <sub>1</sub> /TxD <sub>1</sub>	P9 <sub>1</sub> /TxD <sub>1</sub>	P9 <sub>1</sub> /TxD <sub>1</sub>	P9 <sub>1</sub> /TxD <sub>1</sub>
14	P9 <sub>2</sub> /RxD <sub>0</sub>	P9 <sub>2</sub> /RxD <sub>0</sub>	P9 <sub>2</sub> /RxD <sub>0</sub>	P9 <sub>2</sub> /RxD <sub>0</sub>	P9 <sub>2</sub> /RxD <sub>0</sub>	P9 <sub>2</sub> /RxD <sub>0</sub>
15	P9 <sub>3</sub> /RxD <sub>1</sub>	P9 <sub>3</sub> /RxD <sub>1</sub>	P9 <sub>3</sub> /RxD <sub>1</sub>	P9 <sub>3</sub> /RxD <sub>1</sub>	P9 <sub>3</sub> /RxD <sub>1</sub>	P9 <sub>3</sub> /RxD <sub>1</sub>
16	P9 <sub>4</sub> /SCK <sub>0</sub> /IRQ <sub>4</sub>	P9 <sub>4</sub> /SCK <sub>0</sub> /IRQ <sub>4</sub>	P9 <sub>4</sub> /SCK <sub>0</sub> /IRQ <sub>4</sub>	P9 <sub>4</sub> /SCK <sub>0</sub> /IRQ <sub>4</sub>	P9 <sub>4</sub> /SCK <sub>0</sub> /IRQ <sub>4</sub>	P9 <sub>4</sub> /SCK <sub>0</sub> /IRQ <sub>4</sub>
17	P9 <sub>5</sub> /SCK <sub>1</sub> /IRQ <sub>5</sub>	P9 <sub>5</sub> /SCK <sub>1</sub> /IRQ <sub>5</sub>	P9 <sub>5</sub> /SCK <sub>1</sub> /IRQ <sub>5</sub>	P9 <sub>5</sub> /SCK <sub>1</sub> /IRQ <sub>5</sub>	P9 <sub>5</sub> /SCK <sub>1</sub> /IRQ <sub>5</sub>	P9 <sub>5</sub> /SCK <sub>1</sub> /IRQ <sub>5</sub>
18	P4 <sub>0</sub> /D <sub>0</sub>	P4 <sub>0</sub> /D <sub>0</sub>	P4 <sub>0</sub> /D <sub>0</sub>	P4 <sub>0</sub> /D <sub>0</sub>	P4 <sub>0</sub> /D <sub>0</sub>	P4 <sub>0</sub> /D <sub>0</sub>
19	P4 <sub>1</sub> /D <sub>1</sub>	P4 <sub>1</sub> /D <sub>1</sub>	P4 <sub>1</sub> /D <sub>1</sub>	P4 <sub>1</sub> /D <sub>1</sub>	P4 <sub>1</sub> /D <sub>1</sub>	P4 <sub>1</sub> /D <sub>1</sub>
20	P4 <sub>2</sub> /D <sub>2</sub>	P4 <sub>2</sub> /D <sub>2</sub>	P4 <sub>2</sub> /D <sub>2</sub>	P4 <sub>2</sub> /D <sub>2</sub>	P4 <sub>2</sub> /D <sub>2</sub>	P4 <sub>2</sub> /D <sub>2</sub>
21	P4 <sub>3</sub> /D <sub>3</sub>	P4 <sub>3</sub> /D <sub>3</sub>	P4 <sub>3</sub> /D <sub>3</sub>	P4 <sub>3</sub> /D <sub>3</sub>	P4 <sub>3</sub> /D <sub>3</sub>	P4 <sub>3</sub> /D <sub>3</sub>
22	Vss	Vss	Vss	Vss	Vss	Vss
23	P4 <sub>4</sub> /D <sub>4</sub>	P4 <sub>4</sub> /D <sub>4</sub>	P4 <sub>4</sub> /D <sub>4</sub>	P4 <sub>4</sub> /D <sub>4</sub>	P4 <sub>4</sub> /D <sub>4</sub>	P4 <sub>4</sub> /D <sub>4</sub>
24	P4 <sub>5</sub> /D <sub>5</sub>	P4 <sub>5</sub> /D <sub>5</sub>	P4 <sub>5</sub> /D <sub>5</sub>	P4 <sub>5</sub> /D <sub>5</sub>	P4 <sub>5</sub> /D <sub>5</sub>	P4 <sub>5</sub> /D <sub>5</sub>

**Table H.1 Pin Arrangement of Each Product (FP-100B, TFP-100B) (cont)**

Pin No.	On-chip-ROM Products				ROMless Products	
	H8/3067 Series	H8/3062 Series	H8/3048 Series	H8/3042 Series	H8/3006, 3007	H8/3002
25	P4 <sub>6</sub> /D <sub>6</sub>	P4 <sub>6</sub> /D <sub>6</sub>	P4 <sub>6</sub> /D <sub>6</sub>	P4 <sub>6</sub> /D <sub>6</sub>	P4 <sub>6</sub> /D <sub>6</sub>	P4 <sub>6</sub> /D <sub>6</sub>
26	P4 <sub>7</sub> /D <sub>7</sub>	P4 <sub>7</sub> /D <sub>7</sub>	P4 <sub>7</sub> /D <sub>7</sub>	P4 <sub>7</sub> /D <sub>7</sub>	P4 <sub>7</sub> /D <sub>7</sub>	P4 <sub>7</sub> /D <sub>7</sub>
27	P3 <sub>0</sub> /D <sub>8</sub>	P3 <sub>0</sub> /D <sub>8</sub>	P3 <sub>0</sub> /D <sub>8</sub>	P3 <sub>0</sub> /D <sub>8</sub>	D <sub>8</sub>	D <sub>8</sub>
28	P3 <sub>1</sub> /D <sub>9</sub>	P3 <sub>1</sub> /D <sub>9</sub>	P3 <sub>1</sub> /D <sub>9</sub>	P3 <sub>1</sub> /D <sub>9</sub>	D <sub>9</sub>	D <sub>9</sub>
29	P3 <sub>2</sub> /D <sub>10</sub>	P3 <sub>2</sub> /D <sub>10</sub>	P3 <sub>2</sub> /D <sub>10</sub>	P3 <sub>2</sub> /D <sub>10</sub>	D <sub>10</sub>	D <sub>10</sub>
30	P3 <sub>3</sub> /D <sub>11</sub>	P3 <sub>3</sub> /D <sub>11</sub>	P3 <sub>3</sub> /D <sub>11</sub>	P3 <sub>3</sub> /D <sub>11</sub>	D <sub>11</sub>	D <sub>11</sub>
31	P3 <sub>4</sub> /D <sub>12</sub>	P3 <sub>4</sub> /D <sub>12</sub>	P3 <sub>4</sub> /D <sub>12</sub>	P3 <sub>4</sub> /D <sub>12</sub>	D <sub>12</sub>	D <sub>12</sub>
32	P3 <sub>5</sub> /D <sub>13</sub>	P3 <sub>5</sub> /D <sub>13</sub>	P3 <sub>5</sub> /D <sub>13</sub>	P3 <sub>5</sub> /D <sub>13</sub>	D <sub>13</sub>	D <sub>13</sub>
33	P3 <sub>6</sub> /D <sub>14</sub>	P3 <sub>6</sub> /D <sub>14</sub>	P3 <sub>6</sub> /D <sub>14</sub>	P3 <sub>6</sub> /D <sub>14</sub>	D <sub>14</sub>	D <sub>14</sub>
34	P3 <sub>7</sub> /D <sub>15</sub>	P3 <sub>7</sub> /D <sub>15</sub>	P3 <sub>7</sub> /D <sub>15</sub>	P3 <sub>7</sub> /D <sub>15</sub>	D <sub>15</sub>	D <sub>15</sub>
35	Vcc	Vcc	Vcc	Vcc	Vcc	Vcc
36	P1 <sub>0</sub> /A <sub>0</sub>	P1 <sub>0</sub> /A <sub>0</sub>	P1 <sub>0</sub> /A <sub>0</sub>	P1 <sub>0</sub> /A <sub>0</sub>	A <sub>0</sub>	A <sub>0</sub>
37	P1 <sub>1</sub> /A <sub>1</sub>	P1 <sub>1</sub> /A <sub>1</sub>	P1 <sub>1</sub> /A <sub>1</sub>	P1 <sub>1</sub> /A <sub>1</sub>	A <sub>1</sub>	A <sub>1</sub>
38	P1 <sub>2</sub> /A <sub>2</sub>	P1 <sub>2</sub> /A <sub>2</sub>	P1 <sub>2</sub> /A <sub>2</sub>	P1 <sub>2</sub> /A <sub>2</sub>	A <sub>2</sub>	A <sub>2</sub>
39	P1 <sub>3</sub> /A <sub>3</sub>	P1 <sub>3</sub> /A <sub>3</sub>	P1 <sub>3</sub> /A <sub>3</sub>	P1 <sub>3</sub> /A <sub>3</sub>	A <sub>3</sub>	A <sub>3</sub>
40	P1 <sub>4</sub> /A <sub>4</sub>	P1 <sub>4</sub> /A <sub>4</sub>	P1 <sub>4</sub> /A <sub>4</sub>	P1 <sub>4</sub> /A <sub>4</sub>	A <sub>4</sub>	A <sub>4</sub>
41	P1 <sub>5</sub> /A <sub>5</sub>	P1 <sub>5</sub> /A <sub>5</sub>	P1 <sub>5</sub> /A <sub>5</sub>	P1 <sub>5</sub> /A <sub>5</sub>	A <sub>5</sub>	A <sub>5</sub>
42	P1 <sub>6</sub> /A <sub>6</sub>	P1 <sub>6</sub> /A <sub>6</sub>	P1 <sub>6</sub> /A <sub>6</sub>	P1 <sub>6</sub> /A <sub>6</sub>	A <sub>6</sub>	A <sub>6</sub>
43	P1 <sub>7</sub> /A <sub>7</sub>	P1 <sub>7</sub> /A <sub>7</sub>	P1 <sub>7</sub> /A <sub>7</sub>	P1 <sub>7</sub> /A <sub>7</sub>	A <sub>7</sub>	A <sub>7</sub>
44	Vss	Vss	Vss	Vss	Vss	Vss
45	P2 <sub>0</sub> /A <sub>8</sub>	P2 <sub>0</sub> /A <sub>8</sub>	P2 <sub>0</sub> /A <sub>8</sub>	P2 <sub>0</sub> /A <sub>8</sub>	A <sub>8</sub>	A <sub>8</sub>
46	P2 <sub>1</sub> /A <sub>9</sub>	P2 <sub>1</sub> /A <sub>9</sub>	P2 <sub>1</sub> /A <sub>9</sub>	P2 <sub>1</sub> /A <sub>9</sub>	A <sub>9</sub>	A <sub>9</sub>
47	P2 <sub>2</sub> /A <sub>10</sub>	P2 <sub>2</sub> /A <sub>10</sub>	P2 <sub>2</sub> /A <sub>10</sub>	P2 <sub>2</sub> /A <sub>10</sub>	A <sub>10</sub>	A <sub>10</sub>
48	P2 <sub>3</sub> /A <sub>11</sub>	P2 <sub>3</sub> /A <sub>11</sub>	P2 <sub>3</sub> /A <sub>11</sub>	P2 <sub>3</sub> /A <sub>11</sub>	A <sub>11</sub>	A <sub>11</sub>
49	P2 <sub>4</sub> /A <sub>12</sub>	P2 <sub>4</sub> /A <sub>12</sub>	P2 <sub>4</sub> /A <sub>12</sub>	P2 <sub>4</sub> /A <sub>12</sub>	A <sub>12</sub>	A <sub>12</sub>
50	P2 <sub>5</sub> /A <sub>13</sub>	P2 <sub>5</sub> /A <sub>13</sub>	P2 <sub>5</sub> /A <sub>13</sub>	P2 <sub>5</sub> /A <sub>13</sub>	A <sub>13</sub>	A <sub>13</sub>
51	P2 <sub>6</sub> /A <sub>14</sub>	P2 <sub>6</sub> /A <sub>14</sub>	P2 <sub>6</sub> /A <sub>14</sub>	P2 <sub>6</sub> /A <sub>14</sub>	A <sub>14</sub>	A <sub>14</sub>
52	P2 <sub>7</sub> /A <sub>15</sub>	P2 <sub>7</sub> /A <sub>15</sub>	P2 <sub>7</sub> /A <sub>15</sub>	P2 <sub>7</sub> /A <sub>15</sub>	A <sub>15</sub>	A <sub>15</sub>
53	P5 <sub>0</sub> /A <sub>16</sub>	P5 <sub>0</sub> /A <sub>16</sub>	P5 <sub>0</sub> /A <sub>16</sub>	P5 <sub>0</sub> /A <sub>16</sub>	A <sub>16</sub>	A <sub>16</sub>
54	P5 <sub>1</sub> /A <sub>17</sub>	P5 <sub>1</sub> /A <sub>17</sub>	P5 <sub>1</sub> /A <sub>17</sub>	P5 <sub>1</sub> /A <sub>17</sub>	A <sub>17</sub>	A <sub>17</sub>
55	P5 <sub>2</sub> /A <sub>18</sub>	P5 <sub>2</sub> /A <sub>18</sub>	P5 <sub>2</sub> /A <sub>18</sub>	P5 <sub>2</sub> /A <sub>18</sub>	A <sub>18</sub>	A <sub>18</sub>
56	P5 <sub>3</sub> /A <sub>19</sub>	P5 <sub>3</sub> /A <sub>19</sub>	P5 <sub>3</sub> /A <sub>19</sub>	P5 <sub>3</sub> /A <sub>19</sub>	A <sub>19</sub>	A <sub>19</sub>

**Table H.1 Pin Arrangement of Each Product (FP-100B, TFP-100B) (cont)**

Pin No.	On-chip-ROM Products				ROMless Products	
	H8/3067 Series	H8/3062 Series	H8/3048 Series	H8/3042 Series	H8/3006, 3007	H8/3002
57	V <sub>SS</sub>	V <sub>SS</sub>	V <sub>SS</sub>	V <sub>SS</sub>	V <sub>SS</sub>	V <sub>SS</sub>
58	P6 <sub>0</sub> /WAIT	P6 <sub>0</sub> /WAIT	P6 <sub>0</sub> /WAIT	P6 <sub>0</sub> /WAIT	P6 <sub>0</sub> /WAIT	P6 <sub>0</sub> /WAIT
59	P6 <sub>1</sub> /BREQ	P6 <sub>1</sub> /BREQ	P6 <sub>1</sub> /BREQ	P6 <sub>1</sub> /BREQ	P6 <sub>1</sub> /BREQ	P6 <sub>1</sub> /BREQ
60	P6 <sub>2</sub> /BACK	P6 <sub>2</sub> /BACK	P6 <sub>2</sub> /BACK	P6 <sub>2</sub> /BACK	P6 <sub>2</sub> /BACK	P6 <sub>2</sub> /BACK
	P6 <sub>7</sub>	P6 <sub>7</sub>	φ	φ	P6 <sub>7</sub>	φ
62	STBY	STBY	STBY	STBY	STBY	STBY
63	RES	RES	RES	RES	RES	RES
64	NMI	NMI	NMI	NMI	NMI	NMI
65	V <sub>SS</sub>	V <sub>SS</sub>	V <sub>SS</sub>	V <sub>SS</sub>	V <sub>SS</sub>	V <sub>SS</sub>
66	EXTAL	EXTAL	EXTAL	EXTAL	EXTAL	EXTAL
67	XTAL	XTAL	XTAL	XTAL	XTAL	XTAL
68	V <sub>CC</sub>	V <sub>CC</sub>	V <sub>CC</sub>	V <sub>CC</sub>	V <sub>CC</sub>	V <sub>CC</sub>
69	P6 <sub>3</sub> /AS	P6 <sub>3</sub> /AS	P6 <sub>3</sub> /AS	P6 <sub>3</sub> /AS	AS	AS
70	P6 <sub>4</sub> /RD	P6 <sub>4</sub> /RD	P6 <sub>4</sub> /RD	P6 <sub>4</sub> /RD	RD	RD
71	P6 <sub>5</sub> /HWR	P6 <sub>5</sub> /HWR	P6 <sub>5</sub> /HWR	P6 <sub>5</sub> /HWR	HWR	HWR
72	P6 <sub>6</sub> /LWR	P6 <sub>6</sub> /LWR	P6 <sub>6</sub> /LWR	P6 <sub>6</sub> /LWR	LWR	LWR
73	MD <sub>0</sub>	MD <sub>0</sub>	MD <sub>0</sub>	MD <sub>0</sub>	MD <sub>0</sub>	MD <sub>0</sub>
74	MD <sub>1</sub>	MD <sub>1</sub>	MD <sub>1</sub>	MD <sub>1</sub>	MD <sub>1</sub>	MD <sub>1</sub>
75	MD <sub>2</sub>	MD <sub>2</sub>	MD <sub>2</sub>	MD <sub>2</sub>	MD <sub>2</sub>	MD <sub>2</sub>
76	AV <sub>CC</sub>	AV <sub>CC</sub>	AV <sub>CC</sub>	AV <sub>CC</sub>	AV <sub>CC</sub>	AV <sub>CC</sub>
77	V <sub>REF</sub>	V <sub>REF</sub>	V <sub>REF</sub>	V <sub>REF</sub>	V <sub>REF</sub>	V <sub>REF</sub>
78	P7 <sub>0</sub> /AN <sub>0</sub>	P7 <sub>0</sub> /AN <sub>0</sub>	P7 <sub>0</sub> /AN <sub>0</sub>	P7 <sub>0</sub> /AN <sub>0</sub>	P7 <sub>0</sub> /AN <sub>0</sub>	P7 <sub>0</sub> /AN <sub>0</sub>
79	P7 <sub>1</sub> /AN <sub>1</sub>	P7 <sub>1</sub> /AN <sub>1</sub>	P7 <sub>1</sub> /AN <sub>1</sub>	P7 <sub>1</sub> /AN <sub>1</sub>	P7 <sub>1</sub> /AN <sub>1</sub>	P7 <sub>1</sub> /AN <sub>1</sub>
80	P7 <sub>2</sub> /AN <sub>2</sub>	P7 <sub>2</sub> /AN <sub>2</sub>	P7 <sub>2</sub> /AN <sub>2</sub>	P7 <sub>2</sub> /AN <sub>2</sub>	P7 <sub>2</sub> /AN <sub>2</sub>	P7 <sub>2</sub> /AN <sub>2</sub>
81	P7 <sub>3</sub> /AN <sub>3</sub>	P7 <sub>3</sub> /AN <sub>3</sub>	P7 <sub>3</sub> /AN <sub>3</sub>	P7 <sub>3</sub> /AN <sub>3</sub>	P7 <sub>3</sub> /AN <sub>3</sub>	P7 <sub>3</sub> /AN <sub>3</sub>
82	P7 <sub>4</sub> /AN <sub>4</sub>	P7 <sub>4</sub> /AN <sub>4</sub>	P7 <sub>4</sub> /AN <sub>4</sub>	P7 <sub>4</sub> /AN <sub>4</sub>	P7 <sub>4</sub> /AN <sub>4</sub>	P7 <sub>4</sub> /AN <sub>4</sub>
83	P7 <sub>5</sub> /AN <sub>5</sub>	P7 <sub>5</sub> /AN <sub>5</sub>	P7 <sub>5</sub> /AN <sub>5</sub>	P7 <sub>5</sub> /AN <sub>5</sub>	P7 <sub>5</sub> /AN <sub>5</sub>	P7 <sub>5</sub> /AN <sub>5</sub>
	P7 <sub>ε</sub>	P7 <sub>ε</sub>	P7 <sub>ε</sub>	P7 <sub>ε</sub>	P7 <sub>ε</sub>	P7 <sub>ε</sub> /AN <sub>6</sub>
	P7 <sub>7</sub>	P7 <sub>7</sub>	P7 <sub>7</sub>	P7 <sub>7</sub>	P7 <sub>7</sub>	P7 <sub>7</sub> /AN <sub>7</sub>
86	AV <sub>SS</sub>	AV <sub>SS</sub>	AV <sub>SS</sub>	AV <sub>SS</sub>	AV <sub>SS</sub>	AV <sub>SS</sub>
	P8 <sub>c</sub>	P8 <sub>c</sub>	P8 <sub>c</sub>	P8 <sub>c</sub>	P8 <sub>c</sub>	P8 <sub>0</sub> /RFSH/IRQ <sub>0</sub>
88	P8 <sub>1</sub> /CS <sub>3</sub> /IRQ <sub>1</sub>	P8 <sub>1</sub> /CS <sub>3</sub> /IRQ <sub>1</sub>	P8 <sub>1</sub> /CS <sub>3</sub> /IRQ <sub>1</sub>	P8 <sub>1</sub> /CS <sub>3</sub> /IRQ <sub>1</sub>	P8 <sub>1</sub> /CS <sub>3</sub> /IRQ <sub>1</sub>	P8 <sub>1</sub> /CS <sub>3</sub> /IRQ <sub>1</sub>

**Table H.1 Pin Arrangement of Each Product (FP-100B, TFP-100B) (cont)**

Pin No.	On-chip-ROM Products				ROMless Products	
	H8/3067 Series	H8/3062 Series	H8/3048 Series	H8/3042 Series	H8/3006, 3007	H8/3002
89	P8 <sub>2</sub> /CS <sub>2</sub> /IRQ <sub>2</sub>	P8 <sub>2</sub> /CS <sub>2</sub> /IRQ <sub>2</sub>	P8 <sub>2</sub> /CS <sub>2</sub> /IRQ <sub>2</sub>	P8 <sub>2</sub> /CS <sub>2</sub> /IRQ <sub>2</sub>	P8 <sub>2</sub> /CS <sub>2</sub> /IRQ <sub>2</sub>	P8 <sub>2</sub> /CS <sub>2</sub> /IRQ <sub>2</sub>
	P8 <sub>2</sub> AD	P8 <sub>2</sub> AD	P8 <sub>3</sub>	P8 <sub>3</sub>	P8 <sub>2</sub> AD	P8 <sub>3</sub> /CS <sub>1</sub> /IRQ <sub>3</sub>
91	P8 <sub>4</sub> /CS <sub>0</sub>	P8 <sub>4</sub> /CS <sub>0</sub>	P8 <sub>4</sub> /CS <sub>0</sub>	P8 <sub>4</sub> /CS <sub>0</sub>	P8 <sub>4</sub> /CS <sub>0</sub>	P8 <sub>4</sub> /CS <sub>0</sub>
92	Vss	Vss	Vss	Vss	Vss	Vss
	PA <sub>1</sub> TEI	PA <sub>1</sub>	PA <sub>1</sub> TEI	PA <sub>1</sub> TEI	PA <sub>1</sub> TEI	PA <sub>0</sub> /TP <sub>0</sub> / TEND <sub>0</sub> /TCLKA
	PA <sub>1</sub> TEI	PA <sub>1</sub>	PA <sub>1</sub> TEI	PA <sub>1</sub> TEI	PA <sub>1</sub> TEI	PA <sub>1</sub> /TP <sub>1</sub> / TEND <sub>1</sub> /TCLKB
95	PA <sub>2</sub> /TP <sub>2</sub> / TIOCA <sub>0</sub> /TCLKC	PA <sub>2</sub> /TP <sub>2</sub> / TIOCA <sub>0</sub> /TCLKC	PA <sub>2</sub> /TP <sub>2</sub> / TIOCA <sub>0</sub> /TCLKC	PA <sub>2</sub> /TP <sub>2</sub> / TIOCA <sub>0</sub> /TCLKC	PA <sub>2</sub> /TP <sub>2</sub> / TIOCA <sub>0</sub> /TCLKC	PA <sub>2</sub> /TP <sub>2</sub> / TIOCA <sub>0</sub> /TCLKC
96	PA <sub>3</sub> /TP <sub>3</sub> / TIOCB <sub>0</sub> /TCLKD	PA <sub>3</sub> /TP <sub>3</sub> / TIOCB <sub>0</sub> /TCLKD	PA <sub>3</sub> /TP <sub>3</sub> / TIOCB <sub>0</sub> /TCLKD	PA <sub>3</sub> /TP <sub>3</sub> / TIOCB <sub>0</sub> /TCLKD	PA <sub>3</sub> /TP <sub>3</sub> / TIOCB <sub>0</sub> /TCLKD	PA <sub>3</sub> /TP <sub>3</sub> / TIOCB <sub>0</sub> /TCLKD
	PA <sub>1</sub> TIC	PA <sub>1</sub> TIC	PA <sub>1</sub> TIC	PA <sub>1</sub> TIC	PA <sub>1</sub> TIC	PA <sub>4</sub> /TP <sub>4</sub> / TIOCA <sub>1</sub> /A <sub>23</sub>
	PA <sub>1</sub> TIC	PA <sub>1</sub> TIC	PA <sub>1</sub> TIC	PA <sub>1</sub> TIC	PA <sub>1</sub> TIC	PA <sub>5</sub> /TP <sub>5</sub> / TIOCB <sub>1</sub> /A <sub>22</sub>
	PA <sub>1</sub> TIC	PA <sub>1</sub> TIC	PA <sub>1</sub> TIC	PA <sub>1</sub> TIC	PA <sub>1</sub> TIC	PA <sub>6</sub> /TP <sub>6</sub> / TIOCA <sub>2</sub> /A <sub>21</sub>
100	PA <sub>7</sub> /TP <sub>7</sub> / TIOCB <sub>2</sub> /A <sub>20</sub>	PA <sub>7</sub> /TP <sub>7</sub> / TIOCB <sub>2</sub> /A <sub>20</sub>	PA <sub>7</sub> /TP <sub>7</sub> / TIOCB <sub>2</sub> /A <sub>20</sub>	PA <sub>7</sub> /TP <sub>7</sub> / TIOCB <sub>2</sub> /A <sub>20</sub>	PA <sub>7</sub> /TP <sub>7</sub> / TIOCB <sub>2</sub> /A <sub>20</sub>	PA <sub>7</sub> /TP <sub>7</sub> / TIOCB <sub>2</sub> /A <sub>20</sub>

Note: \* Functions as RESO in the mask ROM versions, and as FWE in the flash memory and flash memory R versions.



---

## **H8/3067 Series, H8/3067 F-ZTAT™ Hardware Manual**

Publication Date: 1st Edition, March 1998

3rd Edition, February 1999

Published by: Electronic Devices Sales & Marketing Group  
Semiconductor & Integrated Circuits Group  
Hitachi, Ltd.

Edited by: Technical Documentation Group  
UL Media Co., Ltd.

Copyright © Hitachi, Ltd., 1998. All rights reserved. Printed in Japan.