

MITSUBISHI ICs (TV)  
**M52328SP**

**WIDEBAND 3-CHANNEL VIDEO AMPLIFIER**

**DESCRIPTION**

M52328SP semiconductor integrated circuit is a wideband video amplifier. Its family products include M51392P, M51399P, M51387P and M52307P. This IC has a 130MHz band and 3 built-in channels. Each channel is provided with a wideband amplifier, contrast controls (main and sub), and brightness controls. This IC is optimal for high-resolution color displays.

**FEATURES**

- Produced by a new bipolar wafer processing method, this IC has 3 built-in channels, and operates with low power dissipation. ( $V_{cc} = 12V$ ,  $I_{cc} = 63mA$ )
- Input: 0.7 V<sub>P-P</sub> (typ)  
Output: 4.5 V<sub>P-P</sub> (max)  
Frequency band: 130 MHz (3 V<sub>P-P</sub>)
- Contrast and brightness can be controlled with a main control. The main control changes contrast or brightness of 3 channels simultaneously. The sub control changes contrast of each channel independently.

**APPLICATION**

Cathode-ray tube displays

**PIN CONFIGURATION (TOP VIEW)**

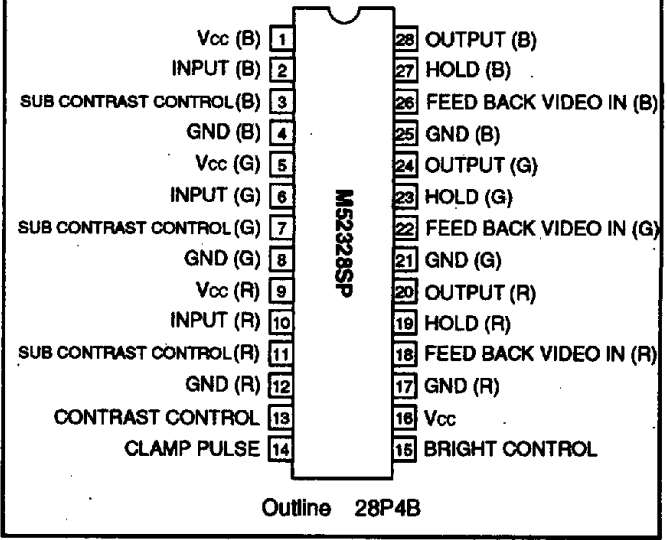

**RECOMMENDED OPERATING CONDITION**

Supply voltage range .....11.5 ~ 12.5 V  
Rated supply voltage ..... 12.0 V

**BLOCK DIAGRAM**

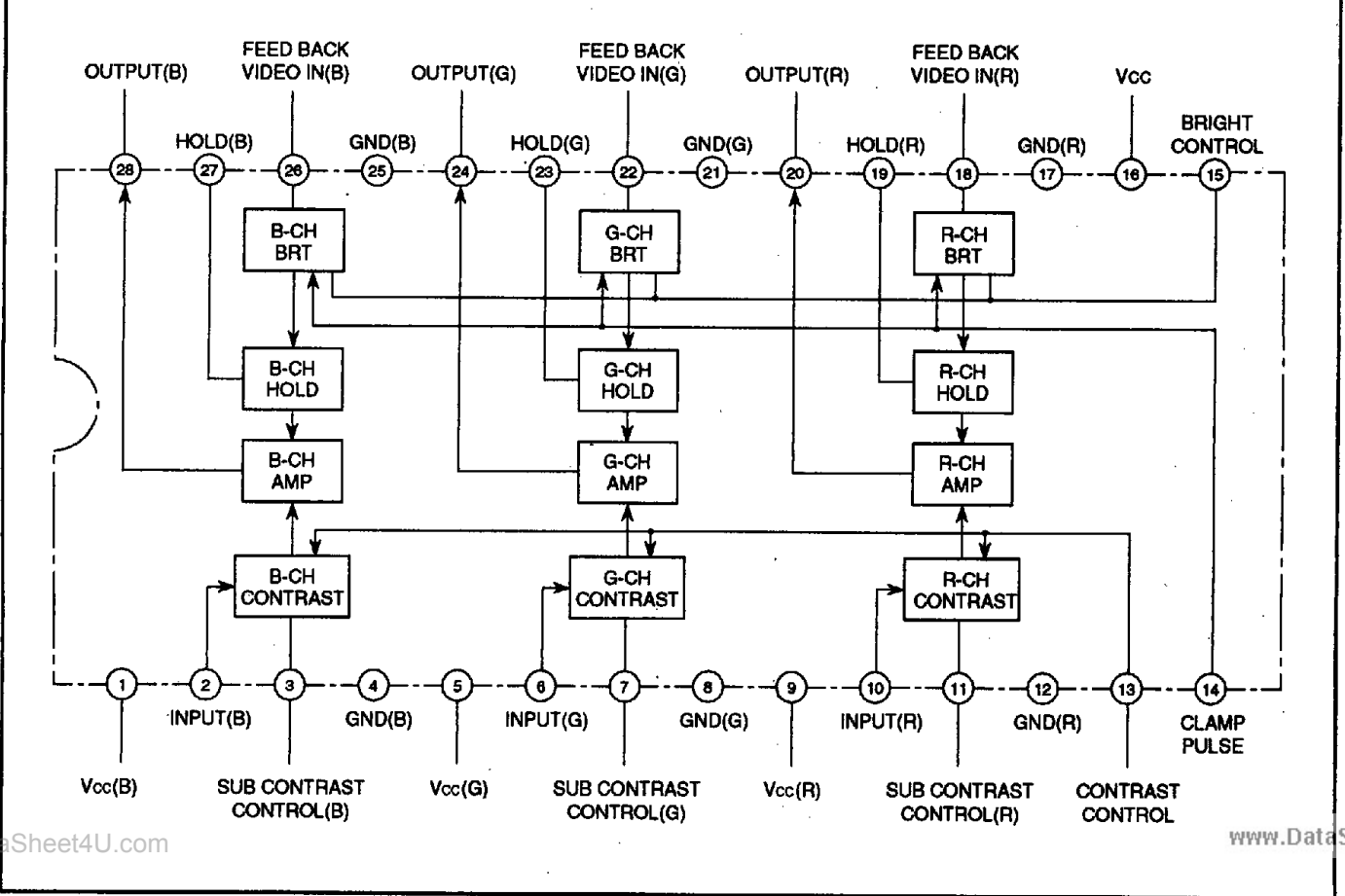

## M52328SP

## WIDEBAND 3-CHANNEL VIDEO AMPLIFIER

## ABSOLUTE MAXIMUM RATINGS

Symbol	Parameter	Rating	Unit
V <sub>cc</sub>	Supply voltage	13.0	V
P <sub>d</sub>	Power dissipation	1580	mW
T <sub>opr</sub>	Operating temperature	-20~+85	°C
T <sub>stg</sub>	Storage temperature	-40~+150	°C
V <sub>opr</sub>	Recommended operating supply voltage	12.0	V
V <sub>opr</sub>	Recommended operating supply voltage range	11.5~12.5	V
Surge	Electrostatic discharge	±200	V

ELECTRICAL CHARACTERISTICS (T<sub>a</sub>=25°C, V<sub>cc</sub>=12V unless otherwise noted.)

Symbol	Parameter	Test point	Test conditions							Limits			Unit
			SW10 R-ch	SW6 G-ch	SW2 B-ch	V3	V13	V15	SW14	Min.	Typ.	Max.	
I <sub>cc</sub>	Circuit current	A	a	a	a	10	10	5.0	b SG6	45	72	100	mA
V <sub>omax.</sub>	Output dynamic range	T.P20 T.P24 T.P28	b SG1	b SG1	b SG1	5.0	5.0	Variable	a	5.8	6.8	9.0	V <sub>P-P</sub>
V <sub>imax.</sub>	Maximum allowable input	T.P20 T.P24 T.P28	b SG1	b SG1	b SG1	5.0	2.0	Variable	a	1.9	2.4	2.9	V <sub>P-P</sub>
G <sub>v</sub>	Maximum gain	T.P20 T.P24 T.P28	b SG1	b SG1	b SG1	5.0	5.0	V <sub>T</sub>	a	13.0	17.0	20.0	dB
ΔG <sub>v</sub>	Relative maximum gain		Relative values to the measurements above							0.8	1.0	1.2	—
V <sub>CR1</sub>	Contrast control characteristic (typ)	T.P20 T.P24 T.P28	b SG1	b SG1	b SG1	5.0	2.0	V <sub>T</sub>	a	6.7	8.5	11.2	dB
ΔV <sub>CR1</sub>	Relative contrast control characteristic (typ)		Relative values to the measurements above							0.8	1.0	1.2	—
V <sub>CR2</sub>	Contrast control characteristic (min)	T.P20 T.P24 T.P28	b SG1	b SG1	b SG1	5.0	0	V <sub>T</sub>	a	10	140	500	mV <sub>P-P</sub>
ΔV <sub>CR2</sub>	Relative contrast control characteristic (min)		Relative values to the measurements above							0.8	1.0	1.3	—
V <sub>SCR1</sub>	Sub contrast control characteristic (typ)	T.P20 T.P24 T.P28	b SG1	b SG1	b SG1	2.0	5.0	V <sub>T</sub>	a	6.5	8.4	11.2	dB
ΔV <sub>SCR1</sub>	Relative sub contrast-control characteristic (typ)		Relative values to the measurements above							0.8	1.0	1.2	—
V <sub>SCR2</sub>	Sub contrast control characteristic (min)	T.P20 T.P24 T.P28	b SG1	b SG1	b SG1	0	5.0	V <sub>T</sub>	a	10	140	500	mV <sub>P-P</sub>
ΔV <sub>SCR2</sub>	Relative sub contrast-control characteristic (min)		Relative values to the measurements above							0.8	1.0	1.2	—
V <sub>CR3</sub>	Contrast/Sub contrast control characteristic (typ)	T.P20 T.P24 T.P28	b SG1	b SG1	b SG1	2.5	2.5	V <sub>T</sub>	a	800	1200	1600	mV <sub>P-P</sub>
ΔV <sub>CR3</sub>	Relative contrast · sub contrast control characteristic (typ)		Relative values to the measurements above							0.8	1.0	1.2	—

## WIDEBAND 3-CHANNEL VIDEO AMPLIFIER

## ELECTRICAL CHARACTERISTICS (cont.)

Symbol	Parameter	Test point	Test conditions							Limits			Unit
			SW10 R-ch	SW6 G-ch	SW2 B-ch	V3	V13	V15	SW14	Min.	Typ.	Max.	
V <sub>B1</sub>	Brightness control characteristic	T.P20 T.P24 T.P28	a —	a —	a —	5.0	5.0	5.5	b SG6	3.7	4.3	4.9	V
ΔV <sub>B1</sub>	Relative brightness control characteristic		Relative values to the measurements above							-100.0	0.0	100.0	mV
F <sub>C1</sub>	Frequency characteristic I (f=50MHz, max)	T.P20 T.P24 T.P28	b SG3	b SG3	b SG3	5.0	4.0	V <sub>T</sub>	a —	-2	-1	3	dB
ΔF <sub>C1</sub>	Relative frequency characteristic I (f=50MHz, max)		Relative values to the measurements above							-1.0	0.0	1.0	dB
F <sub>C1</sub>	Frequency characteristic I (f=130MHz, max)	T.P20 T.P24 T.P28	b SG4	b SG4	b SG4	5.0	4.0	V <sub>T</sub>	a —	-3	-2	3	dB
ΔF <sub>C1</sub>	Relative frequency characteristic I (f=130MHz, max)		Relative values to the measurements above							-1.0	0.0	1.0	dB
F <sub>C2</sub>	Frequency characteristic II (f=50MHz, typ)	T.P20 T.P24 T.P28	b SG3	b SG3	b SG3	5.0	2.5	V <sub>T</sub>	a —	-1	0	3	dB
F <sub>C2</sub>	Frequency characteristic II (f=130MHz, typ)	T.P20 T.P24 T.P28	b SG3	b SG3	b SG3	5.0	2.5	V <sub>T</sub>	a —	-2.5	0	3	dB
F <sub>C3</sub>	Frequency characteristic III (f=50MHz, min)	T.P20 T.P24 T.P28	b SG3	b SG3	b SG3	5.0	0.5	V <sub>T</sub>	a —	-0.5	0	2	dB
F <sub>C3</sub>	Frequency characteristic III (f=130MHz, min)	T.P20 T.P24 T.P28	b SG4	b SG4	b SG4	5.0	0.5	V <sub>T</sub>	a —	-0.5	0	2	dB
C.T.1	Cross talk I (f=50MHz)	T.P20 T.P24 T.P28	b SG3	a —	a —	5.0	5.0	V <sub>T</sub>	a —	—	-32	-20	dB
C.T.1	Cross talk I (f=130MHz)	T.P20 T.P24 T.P28	b SG4	a —	a —	5.0	5.0	V <sub>T</sub>	a —	—	-22	-15	dB
C.T.2	Cross talk II (f=50MHz)	T.P20 T.P24 T.P28	a —	b SG3	a —	5.0	5.0	V <sub>T</sub>	a —	—	-32	-20	dB
C.T.2	Cross talk II (f=130MHz)	T.P20 T.P24 T.P28	a —	b SG4	a —	5.0	5.0	V <sub>T</sub>	a —	—	-22	-15	dB
C.T.3	Cross talk III (f=50MHz)	T.P20 T.P24 T.P28	a —	a —	b SG3	5.0	5.0	V <sub>T</sub>	a —	—	-32	-20	dB
C.T.3	Cross talk III (f=130MHz)	T.P20 T.P24 T.P28	a —	a —	b SG4	5.0	5.0	V <sub>T</sub>	a —	—	-22	-15	dB
T <sub>r</sub>	Pulse characteristic I	T.P20 T.P24 T.P28	b SG5	b SG5	b SG5	5.0	3.5	9.5	b SG6	—	2	4	nsec
T <sub>r</sub>	Pulse characteristic II	T.P20 T.P24 T.P28	b SG5	b SG5	b SG5	5.0	3.5	9.5	b SG6	—	3	6	nsec
V <sub>14th</sub>	Clamp pulse threshold voltage	T.P20 T.P24 T.P28	a —	a —	a —	5.0	5.0	9.5	b SG6	0.7	1.5	2.5	V <sub>bc</sub>

## WIDEBAND 3-CHANNEL VIDEO AMPLIFIER

## ELECTRICAL CHARACTERISTICS (cont.)

Symbol	Parameter	Test point	Test conditions							Limits			Unit
			SW10 R-ch	SW6 G-ch	SW2 B-ch	V3	V13	V15	SW14	Min.	Typ.	Max.	
W <sub>14</sub>	Clamp pulse operating minimum width	T.P20 T.P24 T.P28	a	a	a	5.0	5.0	9.5	b SG6	—	0.3	1.0	μsec
V <sub>27</sub>	Hold voltage	T.P19 T.P23 T.P27	a	a	a	5.0	5.0	9.5	b SG6	3.6	4.3	4.9	V <sub>DC</sub>

## Note

- Only external power supply switch numbers are mentioned in the notes because the signal input pin switch numbers and pulse input pin switch numbers are specified in the electrical characteristic table.
- Sub contrast voltages V3, V7 and V11 are always set to the same level, and V3 represents the other two in the electrical characteristic table.

## ELECTRICAL CHARACTERISTIC TEST METHOD

I<sub>CC</sub>

- Set SW19, SW23 and SW27 to "b."
- Set other conditions as specified in the electrical characteristic table. Set SW1 to "a" and measure current with ammeter A.

V<sub>O</sub> max

- Set SW19, SW23 and SW27 to "b."
- Set V15 in the following procedure.
  - Input SG1 to pin ⑩ (pin ⑥, pin ②). Increase V15 gradually, and read V15 when T.P20 (T.P24, T.P28) output waveform peak distortion starts. This voltage is referred to as V<sub>TR1</sub> (V<sub>TA1</sub>/V<sub>TB1</sub>).
  - Next, decrease V15 gradually, and read V15 when T.P20 (T.P24, T.P28) output waveform pedestal distortion starts. This voltage is referred to as V<sub>TR2</sub> (V<sub>TA2</sub>, V<sub>TB2</sub>).

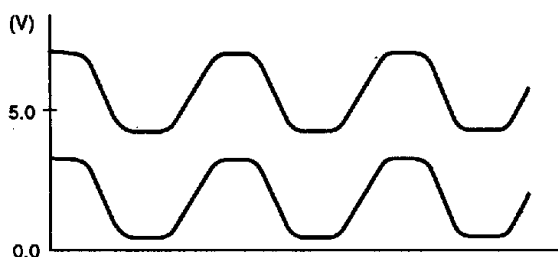

T.P20 Output Waveform  
(T.P24 and T.P28 waveforms are the same.)

- V<sub>T</sub> (V<sub>TR</sub>/V<sub>TA</sub>/V<sub>TB</sub>) can be calculated with the measured voltages, as follows:

$$V_{TR} (V_{TA}, V_{TB}) = \frac{V_{TR1}(V_{TA1}, V_{TB1}) + V_{TR2}(V_{TA2}, V_{TB2})}{2}$$

Use adequate voltages according to the output pin:

- T.P20 output is tested → V<sub>TR1</sub>
  - T.P24 output is tested → V<sub>TA1</sub>
  - T.P28 output is tested → V<sub>TB1</sub>
- After setting V<sub>TR</sub> (V<sub>TA</sub>, V<sub>TB</sub>), increase SG1 amplitude gradually starting from 700 mV, and read output amplitude when T.P20 (T.P24, T.P28) output waveform peak and pedestal distortion starts.

V<sub>I</sub> max

Starting from a V<sub>O</sub> max state, change V13 to 2.0 V as specified in the electrical characteristic table. Increase input signal amplitude gradually, starting from 700 mV<sub>P-P</sub>, and read input signal amplitude when output signal distortion starts.

G<sub>v</sub> and ΔG<sub>v</sub>

- SW19, SW23 and SW27 are all set to "b." Other conditions are as specified in the electric characteristic table.
- Input SG1 to pin ⑩ (pin ⑥, pin ②), and read output amplitude of T.P20 (T.P24, T.P28). The amplitude is referred to as V<sub>OR1</sub> (V<sub>OG1</sub> or V<sub>OB1</sub>).
- Maximum gain G<sub>v</sub> is calculated using the equation shown below:

$$G_v = 20 \log \frac{V_{OR1} (V_{OG1}, V_{OB1}) [V_{P-P}]}{0.7 [V_{P-P}]}$$

- Relative maximum gain ΔG<sub>v</sub> is calculated using the equation shown below:

$$\Delta G_v = V_{OR1}/V_{OG1}, V_{OG1}/V_{OB1}, V_{OB1}/V_{OR1}$$

## M52328SP

## WIDEBAND 3-CHANNEL VIDEO AMPLIFIER

**VCR1 and  $\Delta VCR1$** 

1. Test conditions are the same as specified in the electrical characteristic table, except that V13 is set to 2.0V.
2. Read T.P20(T.P24, T.P28) output amplitude. This amplitude is referred to as  $VOR2(VOG2,VOB2)$ .
3. Contrast control characteristic  $VCR1$  and relative contrast control characteristic  $\Delta VCR1$  are calculated as shown below:

$$VCR1 = 20 \log \frac{VOR2 (VOG2, VOB2) [VP-P]}{0.7 [VP-P]}$$

$$\Delta VCR1 = VOR2 / VOG2,VOG2 / VOB2,VOB2 / VOR1$$

**VCR2 and  $\Delta VCR2$** 

1. Test conditions are the same as specified in the electrical characteristic table, except that V13 is set to 0V.
2. Read T.P20(T.P24, T.P28) output amplitude. This amplitude is referred to as  $VOR3(VOG3,VOB3)$ , and is evaluated as  $VCR2$ .
3. Relative contrast control characteristic  $\Delta VCR2$  is calculated as follows:

**VSCR1 and  $\Delta VSCR1$** 

1. Test conditions are the same as specified in the electrical characteristic table, except that V3, V7 and V11 are set to 2.0V.
2. Read T.P20(T.P24, T.P28) output amplitude. This amplitude is called  $VOR4(VOG4,VOB4)$ .
3. Sub contrast control characteristic  $VSCR1$  and relative sub contrast control characteristic  $\Delta VSCR1$  are calculated as shown below:

$$VSCR1 = 20 \log \frac{VOR4 (VOG4, VOB4) [VP-P]}{0.7 [VP-P]}$$

$$\Delta VSCR1 = VOR4 / VOG4,VOG4 / VOB4,VOB4 / VOR4$$

**VSCR2 and  $\Delta VSCR2$** 

1. Test conditions are the same as specified in the electrical characteristic table, except that V3, V7 and V11 are set to 0V.
2. Read T.P20(T.P24, T.P28) output amplitude. This amplitude is called  $VOR5(VOG5,VOB5)$ , and is evaluated as  $VSCR2$ .
3. Relative sub contrast control characteristic  $\Delta VSCR2$  is calculated as shown below:

$$\Delta VSCR2 = VOR5 / VOG5,VOG5 / VOB5,VOB5 / VOR5$$

**VCR3 and  $\Delta VCR3$** 

1. Test conditions are the same as specified in the electrical characteristic table, except that V3, V7 and V11 are set to 2.5V and V13 to 6.0V.
2. Read T.P20(T.P24, T.P28) amplitude. This amplitude is called  $VOR6(VOG6,VOB6)$ .
3. The gain and relative gain of contrast and sub contrast controls at the standard level are calculated as shown below

$$VCR3 = 20 \log \frac{VOR6 (VOG6, VOB6) [VP-P]}{0.7 [VP-P]}$$

$$\Delta VCR3 = VOR6 / VOG6,VOG6 / VOB6,VOB6 / VOR6$$

**VB1 and  $\Delta VB1$** 

1. The test conditions are the same as specified in the electrical characteristic table.
2. Read T.P20(T.P24, T.P28) output voltage. This voltage is called  $VOR7(VOG7,VOB7)$ , and is evaluated as  $VB1$ .
3. The relative brightness control characteristic is obtained by calculating the difference among the channels with  $VOR7$ ,  $VOG7$  and  $VOB7$ .

$$\Delta VB1 = VOR7 - VOG7 [mV]$$

$$= VOG7 - VOB7$$

$$= VOB7 - VOR7$$

**Fc1,  $\Delta Fc1$ ,  $Fc1'$  and  $\Delta Fc1'$** 

1. Set SW19, SW23 and SW27 to "a." Other test conditions are as specified in the electrical characteristic table.
2. SG3 and SG4 are input. Measure T.P20 (T.P24, T.P28) output waveform amplitude in the same way as Gv and  $\Delta Gv$  testing procedure.
3. This measured value is referred to as:  
Output amplitude  $VOR1(VOG1,VOB1)$ (when SG1 is input),  
Output amplitude  $VOR8(VOG8,VOB8)$ (when SG3 is input), or  
Output amplitude  $VOR9(VOG9,VOB9)$ (when SG4 is input).  
Frequency characteristics  $Fc1$  and  $Fc1'$  are calculated as follows:

$$Fc1 = 20 \log \frac{VOR8 (VOG8, VOB8) [VP-P]}{VOR1 (VOG1, VOB1) [VP-P]}$$

$$Fc1' = 20 \log \frac{VOR9 (VOG9, VOB9) [VP-P]}{VOR1 (VOG1, VOB1) [VP-P]}$$

4. To obtain relative frequency characteristics  $\Delta Fc1$  and  $\Delta Fc1'$ , calculate difference between  $Fc1$  and  $Fc1'$  for each channel.

**Fc2 and Fc2'**

The testing conditions are the same as those for testing  $Fc1$  and  $Fc1'$ , except that CONTRAST (V13) is set to 2.5V

**Fc3 and Fc3'**

The testing conditions are the same as those for testing  $Fc1$  and  $Fc1'$ , except that CONTRAST (V13) is set to 0.5V

**C.T.1 and C.T.1'**

1. Set SW19, SW23 and SW27 to "a." Other test conditions are as specified in the electrical characteristic table.

## M52328SP

## WIDEBAND 3-CHANNEL VIDEO AMPLIFIER

2. Input SG2 (or SG4) to pin ⑩ (R-ch) only, and measure T.P20 (T.P24, T.P28) output waveform amplitude. The measurement is called  $V_{OR}$ ,  $V_{OG}$ ,  $V_{OB}$ .

3. Cross talk C.T.I is calculated as shown below:

$$\text{C.T.I} = 20 \log \frac{V_{OG \text{ or } V_{OB}} [V_{P-P}]}{V_{OR} [V_{P-P}]} \text{ [dB]} \\ (\text{C.T.I}')$$

**C.T.2 and C.T.2'**

1. Change input pin from ⑩ (R-ch) to pin ⑥ (G-ch). Read output in the same manner as that for C.T.I and C.T.I'.

Cross talk C.T.II is calculated as shown below:

$$\text{C.T.II} = 20 \log \frac{V_{OR \text{ or } V_{OB}} [V_{P-P}]}{V_{OG} [V_{P-P}]} \text{ [dB]} \\ (\text{C.T.II}')$$

**C.T.3 and C.T.3'**

1. Change input pin from ⑩ (R-ch) to pin ② (B-ch). Read output in the same manner as that for C.T.I and C.T.I'.

$$\text{C.T.III} = 20 \log \frac{V_{OR \text{ or } V_{OG}} [V_{P-P}]}{V_{OB} [V_{P-P}]} \text{ [dB]} \\ (\text{C.T.III}')$$

**Tr and Tf**

- SW18, SW22 and SW26 are set to "b." Other test conditions are as specified in the electrical characteristic table.
- Read rise time  $Tr_1$  and fall time  $Tf_1$  with an active probe, while input pulse is fluctuating between 10% ~90%.
- Read rise time  $Tr_2$  and fall time  $Tf_2$  with an active probe, while changing output pulse between 10% ~90%.
- Pulse characteristics  $Tr$  and  $Tf$  are calculated as follows:

$$Tr \text{ (ns)} = \sqrt{(Tr_2)^2 - (Tr_1)^2}$$

$$Tf \text{ (ns)} = \sqrt{(Tf_2)^2 - (Tf_1)^2}$$

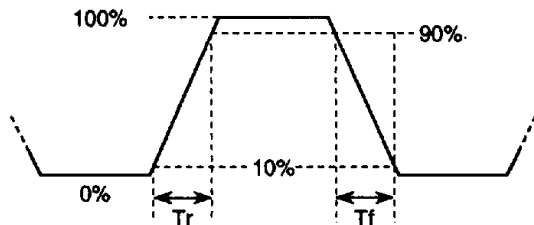
**V14th**

- SW19, SW23 and SW27 are set to "b." Other test conditions are as specified in the electrical characteristic table.
- Monitoring output (2.0 V<sub>bc</sub>), lower the SG6 level, and measure the level when output is 0 V.

**W14**

Under the same conditions as for V14th measurement, decrease SG6 pulse gradually, monitoring output. Measure the SG6 pulse width when output is 0 V.

**V27**

- Set SW19, SW23 and SW27 to "b."
- Read T.P19, T.P23 and T.P27 outputs with voltmeter.

**INPUT SIGNALS**

SG No.	Input signal
SG 1	Sine wave with amplitude 0.7 V <sub>P-P</sub> (100 kHz, amplitude can be varied partially*). 
SG 2	Sine wave with amplitude 0.7 V <sub>P-P</sub> (f = 10 MHz)
SG 3	Sine wave with amplitude 0.7 V <sub>P-P</sub> (f = 50 MHz)
SG 4	Sine wave with amplitude 0.7 V <sub>P-P</sub> (f = 130 MHz)
SG 5	Square wave with amplitude 0.7 V <sub>P-P</sub> (f = 1 MHz, duty = 50%) 
SG 6	Pulse (amplitude 2.0 V <sub>P-P</sub> and pulse width 3.0 μs). Synchronous with standard video staircase pedestal. 
SG 7	standard video staircase 

\* Refer to the electrical characteristic test procedure.

# M52328SP

## WIDEBAND 3-CHANNEL VIDEO AMPLIFIER

### TEST CIRCUIT

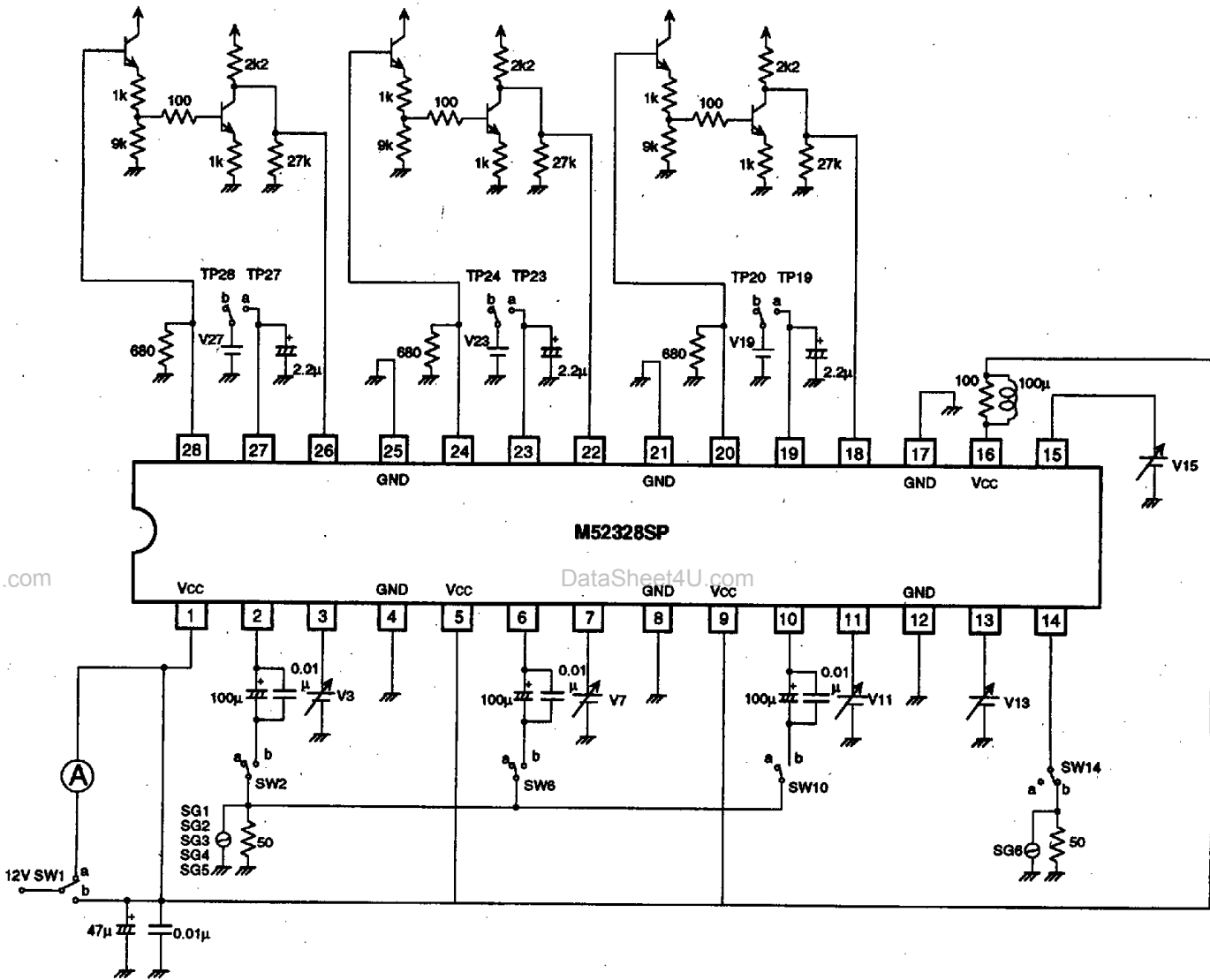

\* Capacitor is 0.01  $\mu$  F unless otherwise specified.  
 Units Resistance :  $\Omega$   
 Capacitance : F

# M52328SP

## WIDEBAND 3-CHANNEL VIDEO AMPLIFIER

### TYPICAL CHARACTERISTICS

**THERMAL DERATING  
(MAXIMUM RATING)**

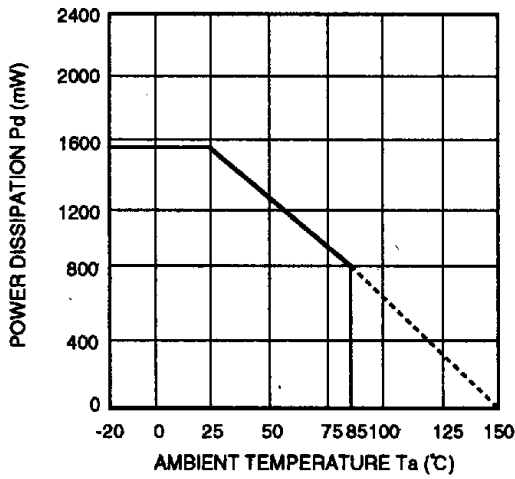

**SUB CONTRAST CHARACTERISTIC**

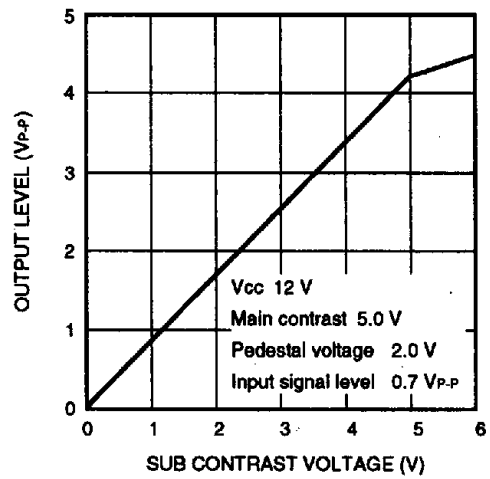

**MAIN CONTRAST CHARACTERISTIC**

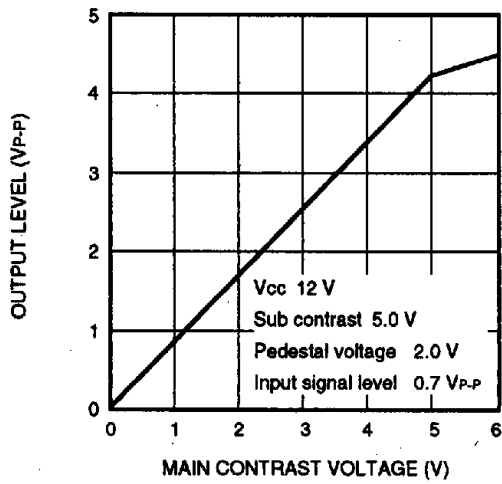

et4U.com

DataSheet4U.com

DataShee

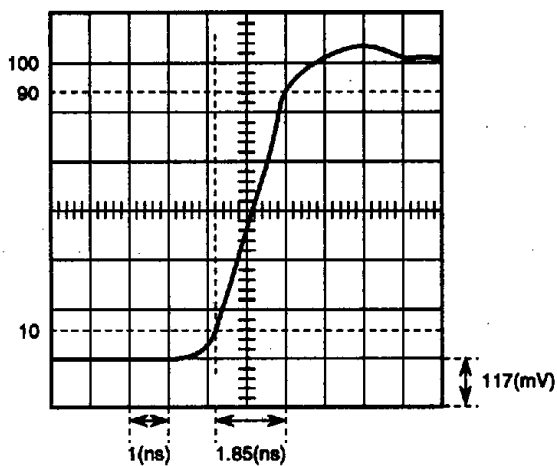

**M52328SP****WIDEBAND 3-CHANNEL VIDEO AMPLIFIER****TYPICAL CHARACTERISTICS (cont.)****M52328SP RISE**

Input signal  
 Square wave  
 Input amplitude 0.70(V<sub>P-P</sub>)  
 Tr in 1.85(ns)

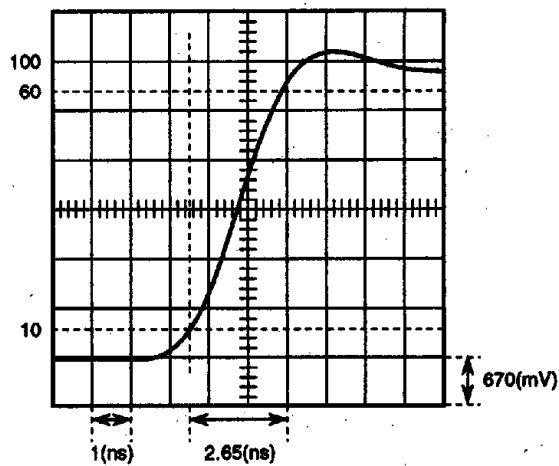

Output signal  
 Output amplitude 4.0(V<sub>P-P</sub>)  
 Tr out 2.65(ns)  
 V<sub>CC</sub> = 12 V  
 Main contrast 4.6 V  
 Sub contrast 5.0V  
 Pedestal voltage 2.0 V

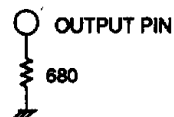

$$\begin{aligned} Tr &= \sqrt{(Tr \text{ out})^2 - (Tr \text{ in})^2} \\ &= \sqrt{2.65^2 - 1.85^2} \\ &\approx 1.9 \text{ (ns)} \end{aligned}$$

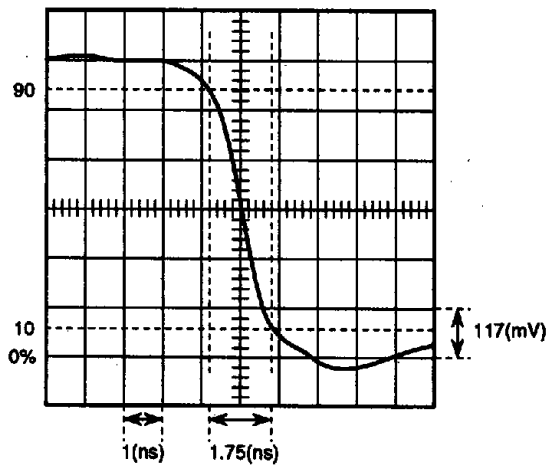
**M52328SP****WIDEBAND 3-CHANNEL VIDEO AMPLIFIER****TYPICAL CHARACTERISTICS (cont.)****M52328SP FALL**

Input signal  
 Square wave  
 Input amplitude 0.70(V<sub>P-P</sub>)  
 Tf in 1.75(ns)

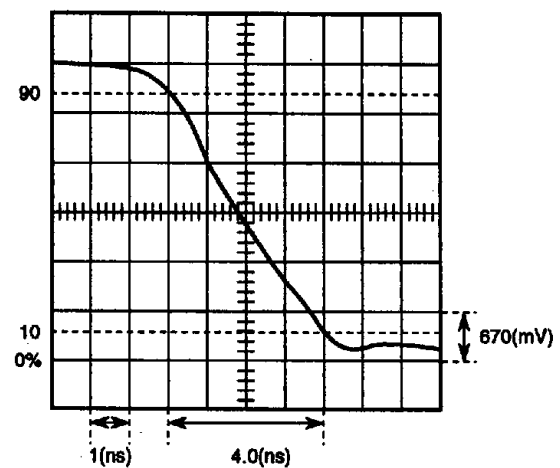

Output signal  
 Output amplitude 4.0(V<sub>P-P</sub>)  
 Tf out 4.0(ns)  
 V<sub>CC</sub> = 12 V  
 Main contrast 4.6 V  
 Sub contrast 5.0V  
 Pedestal voltage 2.0 V

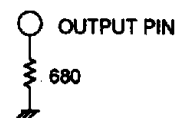

$$\begin{aligned} Tr &= \sqrt{(Tf \text{ out})^2 - (Tf \text{ in})^2} \\ &= \sqrt{4^2 - 1.75^2} \\ &\approx 3.6 \text{ (ns)} \end{aligned}$$

WIDEBAND 3-CHANNEL VIDEO AMPLIFIER

APPLICATION EXAMPLE 1

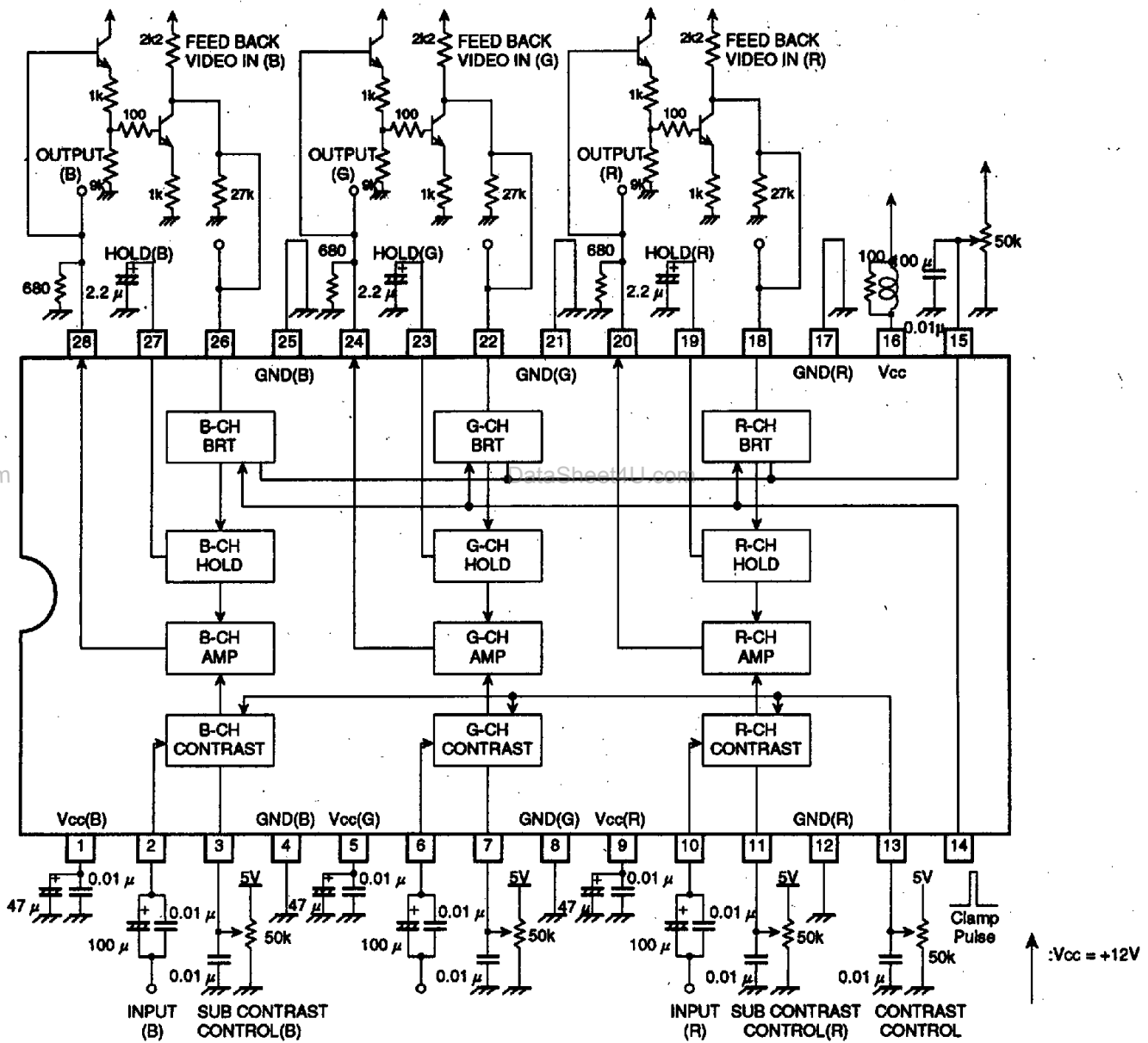

\* Capacitor is 0.01 μ F unless otherwise specified.

Units Resistance : Ω  
Capacitance : F

# M52328SP

## WIDEBAND 3-CHANNEL VIDEO AMPLIFIER

### APPLICATION EXAMPLE 2

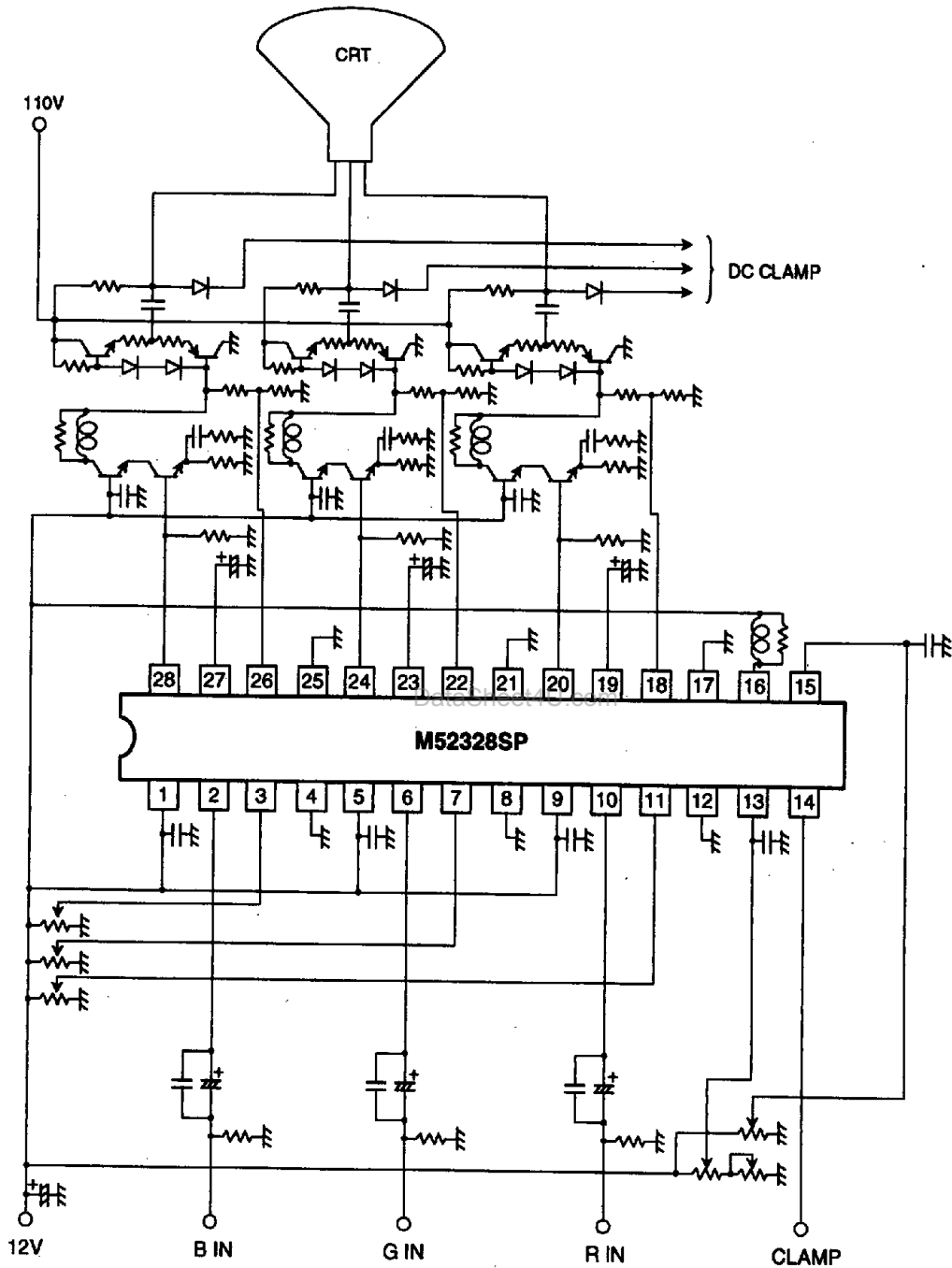

\* Capacitor is 0.01  $\mu$ F unless otherwise specified.  
 Units Resistance :  $\Omega$   
 Capacitance : F

## WIDEBAND 3-CHANNEL VIDEO AMPLIFIER

## DESCRIPTION OF PIN

Pin No.	Name	Voltage and wave information	Peripheral circuit of pins	Remark
① ⑤ ⑨	Vcc(B-ch) Vcc(G-ch) Vcc(R-ch)	12V		Apply equivalent voltage to 3 channels.
② ⑥ ⑩	B-IN G-IN R-IN	2.9V		—
③ ⑦ ⑪	B SUB CONTRAST G SUB CONTRAST R SUB CONTRAST	2.5V		—
④ ⑧ ⑫	GND(B-ch) GND(G-ch) GND(R-ch)	GND	—	—
⑬	CONTRAST	2.5V		—
⑭	CLAMP PULSE	—		—

**M52328SP****WIDEBAND 3-CHANNEL VIDEO AMPLIFIER****DESCRIPTION OF PIN (cont.)**

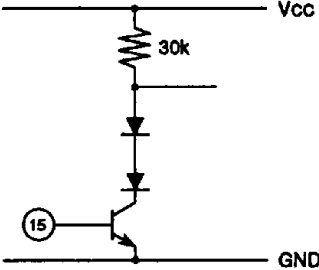
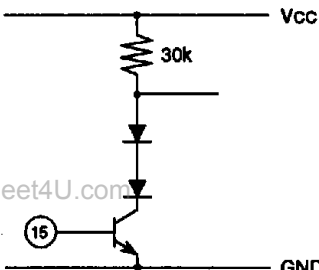
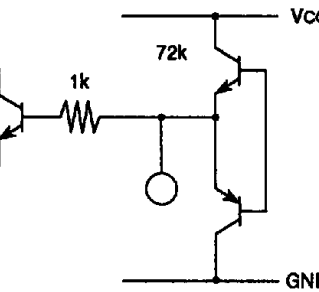
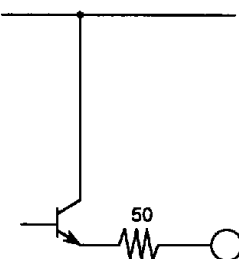
Pin No.	Name	Voltage and wave information	Peripheral circuit of pins	Remark
⑮	BRIGHT	—		—
⑯	Vcc	12V	—	—
⑰ ⑳ ㉑ ㉒	R FEED BACK VIDEO IN G FEED BACK VIDEO IN B FEED BACK VIDEO IN	—		—
⑲ ㉓ ㉔	R HOLD G HOLD B HOLD	Variable		—
㉕ ㉖ ㉗	R OUT G OUT B OUT	Variable		Resistance is necessary on the GND side. Set the resistance for current to be no more than 15mA, according to the driver capacity.

## M52328SP

## WIDEBAND 3-CHANNEL VIDEO AMPLIFIER

## INSTRUCTIONS

## 1) Clamp pulse Input

The clamp pulse is wired as shown in the illustration. The inputs are:

$$V_{TH} = 2.2V - \text{Diode} \times 1 \\ = 1.5V$$

Voltage in excess of 2.2V is suppressed.

The recommended voltage level is as shown in the illustration on the right.

The recommended pulse width is as follows:

1.0  $\mu$ sec or more at 15kHz

0.5  $\mu$ sec or more at 30kHz

0.3  $\mu$ sec or more at 64kHz

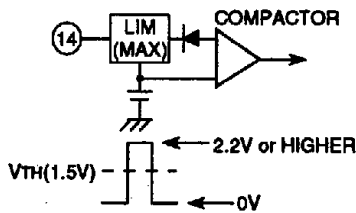

The clamp pulse wiring is usually long in TV sets. It is sometimes led from the high voltage side, or connected indirectly to an external pin. Under such conditions, the wiring may possibly be exposed to high surge voltage. It is recommended that a safety circuit be provided as shown in the illustration on the right.

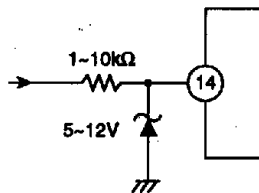

## 2) Brightness control

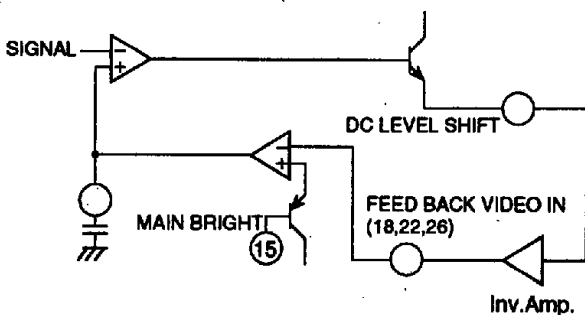

The mechanism is as shown in the illustration above. This IC operates by the external feedback mechanism, and requires DC data from outside.

## 2-1) Feed back pin

Signals are output to pins ⑭, ⑮ and ⑯, and are feed back to pins ⑱, ⑳ and ㉑ through an external circuit as shown in the illustration.

For the feed back signals, only the pedestal potential is sampled by clamp pulse of pin ⑭. It is retained by holding capacitors of pins ⑱, ⑳ and ㉑. Output pin video signal pedestal potential is also retained.

FEED BACK characteristics are explained below, with reference to the diagram.

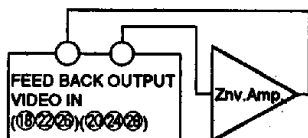

When FEED BACK VIDEO IN pin voltage (VF) is varied while pin ⑮ (bright) voltage (VB) is set to 1.5V and 5.1V, the HOLD pin voltage (VH) changes as lines ① and ② show in the diagram.

As shown by line ①, VH changes around VF = 5.1V point.

When VH is varied without input, VF changes as line ③ indicates in the diagram.

This diagram shows the variation of voltages that are output from OUTPUT pin Vo and then let through an external inversion amplifier. Their characteristics differ depending on the external amplifier, as can be seen from the diagram. The clamp point is intersection ④ where line ① or ② meets line ③.

No intersection may appear depending on VB and the external circuit.

The VB operation range is around 2.5~7.5V when VF changes as line ③ shows while VH is variable. Investigate VF variation characteristics, and lay out the external circuit for VB to be within the control range. It is recommended that output pedestal potential be between 2.0V~3.0V.

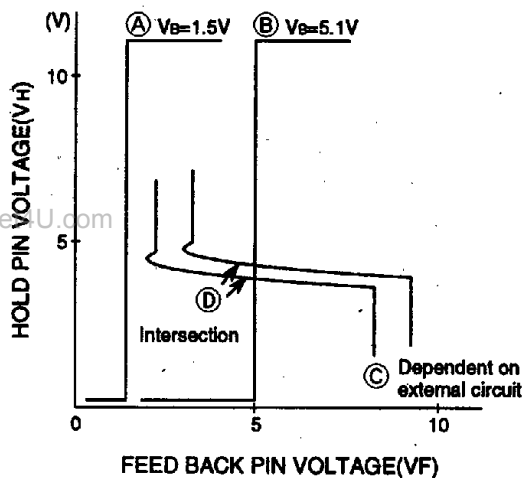

## 2-2) Hold capacitor

Capacitance of no less than 1,000p is required when fH is 15 kHz. However, the required capacitance varies depending on the hold period (operating period except during clamping). Larger capacitance may be necessary if the hold period is longer.

The smaller the capacitance, the quicker the response, and the larger the capacitance, the stable the response. Set the capacitance according to clamp pulse conditions (especially vertical sync timing pulse conditions).

## M52328SP

## WIDEBAND 3-CHANNEL VIDEO AMPLIFIER

## M52328SP Cross talk

Measuring conditions

Main : Contrast pin voltage 5.0V

Sub : Contrast pin voltage 5.0V

Input signal 0.7V<sub>P-P</sub> sine wave

		Input frequency				Unit
		10MHz	50MHz	75MHz	100MHz	
CT1	R→G	-45	-29	-23	-18	dB
	R→B	-60	-38	-30	-20	dB
CT2	G→R	-60	-34	-23	-18	dB
	G→B	-45	-26	-20	-18	dB
CT3	B→R	-65	-35	-23	-19	dB
	B→G	-60	-40	-29	-26	dB

Cross talk Ct1 inputs signals only to pin ⑩ (R-ch). The output waveform amplitudes at pin ⑩, ⑪ and ⑫ are called, respectively, V<sub>OR</sub>, V<sub>OG</sub> and V<sub>OB</sub>.

$$CT1 = 20 \log \frac{V_{OG} \text{ or } V_{OB} [V_{P-P}]}{V_{OR} [V_{P-P}]} \quad [dB]$$

Cross talk CT2 can be calculated in the same way, except that signals are input to pin ⑥ (G-ch).

$$CT2 = 20 \log \frac{V_{OR} \text{ or } V_{OB} [V_{P-P}]}{V_{OG} [V_{P-P}]} \quad [dB]$$

Cross talk CT3 can be calculated in the same way, except that signals are input to pin ② (B-ch).

$$CT3 = 20 \log \frac{V_{OR} \text{ or } V_{OG} [V_{P-P}]}{V_{OB} [V_{P-P}]} \quad [dB]$$

## CIRCUIT BOARD PRODUCTION INSTRUCTIONS

This IC has a built-in wideband amplifier, therefore oscillation may be generated depending on the circuit board wiring layout. Follow the instructions listed below to prevent it.

- Make wiring between output pin and resistance as short as possible.
- Minimize output pin loading capacitance.
- Provide V<sub>CC</sub>-GND, line and DC line bypass capacitors close to the pin.
- Use a stable supply for V<sub>CC</sub>. (The four supplies are desired to be independent of each other.)
- To reduce oscillation, connect a resistance of dozens of ohms between each output pin and the next stage.
- Connecting a coil and a resistor to pin ⑬ V<sub>CC</sub> may also be effective depending on the circuit board.

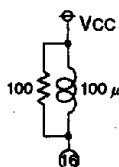

- Check if signals are not deviated from the power stage.
- GND should be as wide as possible. It should be an all-over spread GND pattern as a matter of rule.
- Hold capacitance should be connected to stable GND to be as close to the pin as possible.

## IC OPERATION REMARKS

- It is recommended to control pedestal voltage between 2V ~3V for reduction of distortion.
- Apply sufficiently low impedance to each input.