

# Octal D-type flip-flop with enable

# 74ABT377A

## FEATURES

- Ideal for addressable register applications
- 8-bit positive edge-triggered register
- Enable for address and data synchronization applications
- Output capability: +64mA/-32mA
- Latch-up protection exceeds 500mA per Jedec JC40.2 Std 17
- ESD protection exceeds 2000V per MIL STD 883 Method 3015 and 200V per Machine Model
- Power-up reset

## DESCRIPTION

The 74ABT377A high-performance BiCMOS device combines low static and dynamic power dissipation with high speed and high output drive.

The 74ABT377A has 8 edge-triggered D-type flip-flops with individual D inputs and Q outputs. The common buffered clock (CP) input loads all flip-flops simultaneously when the Enable ( $\bar{E}$ ) input is Low.

The register is fully edge triggered. The state of each D input, one set-up time before the Low-to-High clock transition, is transferred to the corresponding flip-flop's Q output.

The  $\bar{E}$  input must be stable one setup time prior to the Low-to-High clock transition for predictable operation.

## QUICK REFERENCE DATA

SYMBOL	PARAMETER	CONDITIONS $T_{amb} = 25^{\circ}\text{C}; \text{GND} = 0\text{V}$	TYPICAL	UNIT
$t_{PLH}$ $t_{PHL}$	Propagation delay CP to Qn	$C_L = 50\text{pF}; V_{CC} = 5\text{V}$	3.1 3.6	ns
$C_{IN}$	Input capacitance	$V_I = 0\text{V or } V_{CC}$	4	pF
$I_{CCH}$	Total current supply	Outputs High; $V_{CC} = 5.5\text{V}$	500	nA

## ORDERING INFORMATION

PACKAGES	TEMPERATURE RANGE	OUTSIDE NORTH AMERICA	NORTH AMERICA	DWG NUMBER
20-Pin Plastic DIP	-40°C to +85°C	74ABT377A N	74ABT377A N	SOT146-1
20-Pin plastic SO	-40°C to +85°C	74ABT377A D	74ABT377A D	SOT163-1
20-Pin Plastic SSOP Type II	-40°C to +85°C	74ABT377A DB	74ABT377A DB	SOT339-1
20-Pin Plastic TSSOP Type I	-40°C to +85°C	74ABT377A PW	74ABT377PWA DH	SOT360-1

## PIN CONFIGURATION

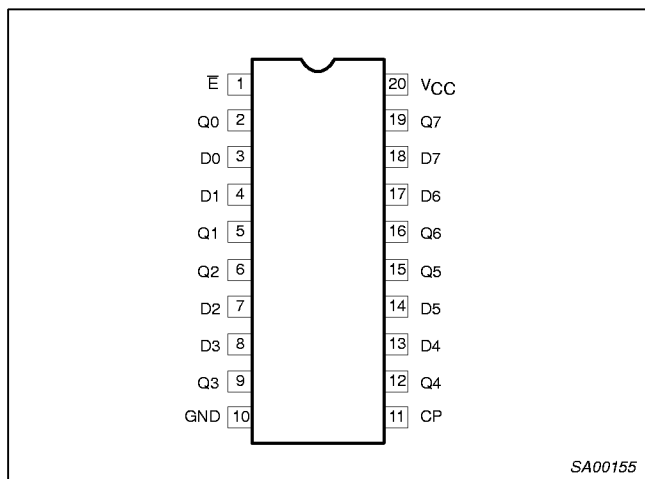

## LOGIC SYMBOL

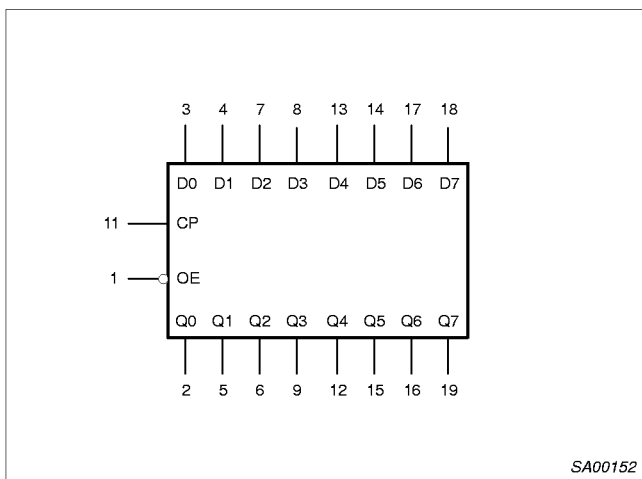

# Octal D-type flip-flop with enable

## 74ABT377A

### LOGIC SYMBOL (IEEE/IEC)

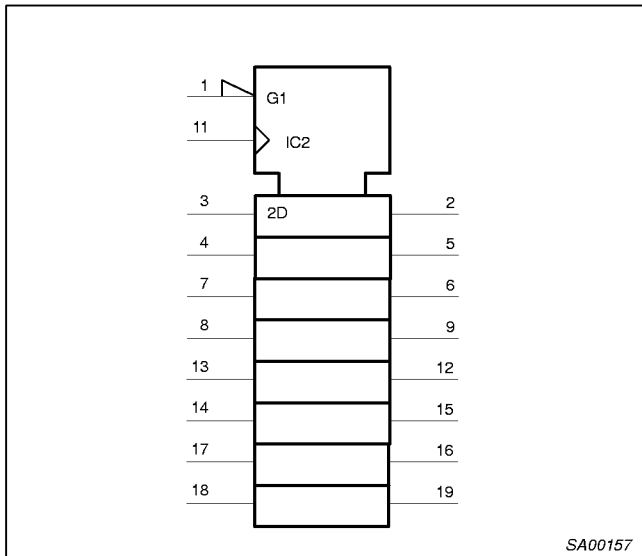

### PIN DESCRIPTION

PIN NUMBER	SYMBOL	FUNCTION
1	$\bar{E}$	Enable input (active-Low)
3, 4, 7, 8, 13, 14, 17, 18	D0-D7	Data inputs
2, 5, 6, 9, 12, 15, 16, 19	Q0-Q7	Data outputs
11	CP	Clock Pulse input (active rising edge)
10	GND	Ground (0V)
20	V <sub>CC</sub>	Positive supply voltage

### LOGIC DIAGRAM

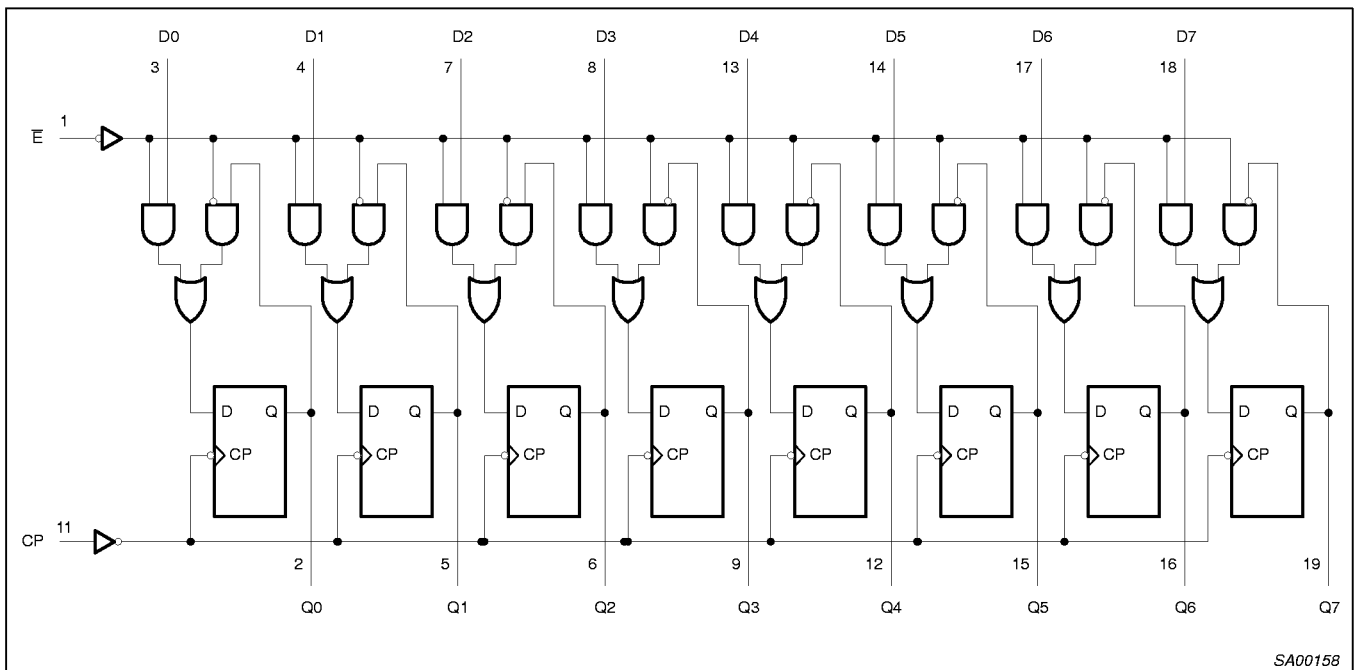

## Octal D-type flip-flop with enable

74ABT377A

## FUNCTION TABLE

INPUTS			OUTPUTS	OPERATING MODE
E	CP	Dn	Qn	
l	↑	h	H	Load "1"
l	↑	l	L	Load "0"
h H	↑ X	X X	no change no change	Hold (do nothing)

H = High voltage level

h = High voltage level one set-up time prior to the Low-to-High clock transition

L = Low voltage level

l = Low voltage level one set-up time prior to the Low-to-High clock transition

X = Don't care

↑ = Low-to-High clock transition

ABSOLUTE MAXIMUM RATINGS<sup>1, 2</sup>

SYMBOL	PARAMETER	CONDITIONS	RATING	UNIT
V <sub>CC</sub>	DC supply voltage		-0.5 to +7.0	V
I <sub>IK</sub>	DC input diode current	V <sub>I</sub> < 0	-18	mA
V <sub>I</sub>	DC input voltage <sup>3</sup>		-1.2 to +7.0	V
I <sub>OK</sub>	DC output diode current	V <sub>O</sub> < 0	-50	mA
V <sub>OUT</sub>	DC output voltage <sup>3</sup>	output in Off or High state	-0.5 to +5.5	V
I <sub>OUT</sub>	DC output current	output in Low state	128	mA
T <sub>stg</sub>	Storage temperature range		-65 to 150	°C

## NOTES:

- Stresses beyond those listed may cause permanent damage to the device. These are stress ratings only and functional operation of the device at these or any other conditions beyond those indicated under "recommended operating conditions" is not implied. Exposure to absolute-maximum-rated conditions for extended periods may affect device reliability.
- The performance capability of a high-performance integrated circuit in conjunction with its thermal environment can create junction temperatures which are detrimental to reliability. The maximum junction temperature of this integrated circuit should not exceed 150°C.
- The input and output voltage ratings may be exceeded if the input and output current ratings are observed.

## RECOMMENDED OPERATING CONDITIONS

SYMBOL	PARAMETER	LIMITS		UNIT
		MIN	MAX	
V <sub>CC</sub>	DC supply voltage	4.5	5.5	V
V <sub>I</sub>	Input voltage	0	V <sub>CC</sub>	V
V <sub>IH</sub>	High-level input voltage	2.0		V
V <sub>IL</sub>	Low-level input voltage		0.8	V
I <sub>OH</sub>	High-level output current		-32	mA
I <sub>OL</sub>	Low-level output current		64	mA
Δt/Δv	Input transition rise or fall rate	0	5	ns/V
T <sub>amb</sub>	Operating free-air temperature range	-40	+85	°C

## Octal D-type flip-flop with enable

74ABT377A

## DC ELECTRICAL CHARACTERISTICS

SYMBOL	PARAMETER	TEST CONDITIONS	LIMITS					UNIT
			T <sub>amb</sub> = +25°C			T <sub>amb</sub> = -40°C to +85°C		
			MIN	TYP	MAX	MIN	MAX	
V <sub>IK</sub>	Input clamp voltage	V <sub>CC</sub> = 4.5V; I <sub>IK</sub> = -18mA		-0.9	-1.2		-1.2	V
V <sub>OH</sub>	High-level output voltage	V <sub>CC</sub> = 4.5V; I <sub>OH</sub> = -3mA; V <sub>I</sub> = V <sub>IL</sub> or V <sub>IH</sub>	2.5	2.9		2.5		V
		V <sub>CC</sub> = 5.0V; I <sub>OH</sub> = -3mA; V <sub>I</sub> = V <sub>IL</sub> or V <sub>IH</sub>	3.0	3.4		3.0		V
		V <sub>CC</sub> = 4.5V; I <sub>OH</sub> = -32mA; V <sub>I</sub> = V <sub>IL</sub> or V <sub>IH</sub>	2.0	2.4		2.0		V
V <sub>OL</sub>	Low-level output voltage	V <sub>CC</sub> = 4.5V; I <sub>OL</sub> = 64mA; V <sub>I</sub> = V <sub>IL</sub> or V <sub>IH</sub>		0.42	0.55		0.55	V
V <sub>RST</sub>	Power-up output low voltage <sup>3</sup>	V <sub>CC</sub> = 5.5V; I <sub>O</sub> = 1mA; V <sub>I</sub> = GND or V <sub>CC</sub>		0.13	0.55		0.55	V
I <sub>I</sub>	Input leakage current	V <sub>CC</sub> = 5.5V; V <sub>I</sub> = GND or 5.5V		±0.01	±1.0		±1.0	µA
I <sub>OFF</sub>	Power-off leakage current	V <sub>CC</sub> = 0.0V; V <sub>O</sub> or V <sub>I</sub> ≤ 4.5V		±5.0	±100		±100	µA
I <sub>CEX</sub>	Output High leakage current	V <sub>CC</sub> = 5.5V; V <sub>O</sub> = 5.5V; V <sub>I</sub> = GND or V <sub>CC</sub>		5.0	50		50	µA
I <sub>O</sub>	Output current <sup>1</sup>	V <sub>CC</sub> = 5.5V; V <sub>O</sub> = 2.5V	-50	-100	-180	-50	-180	mA
I <sub>CCH</sub>	Quiescent supply current	V <sub>CC</sub> = 5.5V; Outputs High, V <sub>I</sub> = GND or V <sub>CC</sub>		0.5	250		250	µA
I <sub>CCL</sub>		V <sub>CC</sub> = 5.5V; Outputs Low, V <sub>I</sub> = GND or V <sub>CC</sub>		24	30		30	mA
ΔI <sub>CC</sub>	Additional supply current per input pin <sup>2</sup>	V <sub>CC</sub> = 5.5V; one input at 3.4V, other inputs at V <sub>CC</sub> or GND		0.5	1.5		1.5	mA

## NOTES:

- Not more than one output should be tested at a time, and the duration of the test should not exceed one second.
- This is the increase in supply current for each input at 3.4V.
- For valid test results, data must not be loaded into the flip-flops (or latches) after applying the power.

## AC CHARACTERISTICS

GND = 0V, t<sub>R</sub> = t<sub>F</sub> = 2.5ns, C<sub>L</sub> = 50pF, R<sub>L</sub> = 500Ω

SYMBOL	PARAMETER	WAVEFORM	LIMITS <sup>1</sup>					UNIT
			T <sub>amb</sub> = +25°C V <sub>CC</sub> = +5.0V			T <sub>amb</sub> = -40 to +85°C V <sub>CC</sub> = +5.0V ±0.5V		
			MIN	TYP	MAX	MIN	MAX	
f <sub>MAX</sub>	Maximum clock frequency	1	150	250		150		MHz
t <sub>PLH</sub> t <sub>PHL</sub>	Propagation delay CP to Qn	1	1.8	3.1	4.0	1.8	4.8	ns
			2.2	3.6	4.7	2.2	4.9	

## NOTE:

- Limits may vary among suppliers.

# Octal D-type flip-flop with enable

74ABT377A

## AC SETUP REQUIREMENTS

GND = 0V,  $t_R = t_F = 2.5\text{ns}$ ,  $C_L = 50\text{pF}$ ,  $R_L = 500\Omega$

SYMBOL	PARAMETER	WAVEFORM	LIMITS			UNIT
			$T_{\text{amb}} = +25^\circ\text{C}$ $V_{\text{CC}} = +5.0\text{V}$		$T_{\text{amb}} = -40 \text{ to } +85^\circ\text{C}$ $V_{\text{CC}} = +5.0\text{V} \pm 0.5\text{V}$	
			MIN	TYP	MIN	
$t_s(\text{H})$ $t_s(\text{L})$	Setup time, High or Low Dn to CP	2	1.5 1.5	0.7 0.5	1.5 1.5	ns
$t_h(\text{H})$ $t_h(\text{L})$	Hold time, High or Low Dn to CP	2	1.0 1.0	-0.4 -0.6	1.0 1.0	ns
$t_s(\text{H})$ $t_s(\text{L})$	Setup time, High or Low $\bar{E}$ to CP	2	2.0 2.0	1.1 1.0	2.0 2.0	ns
$t_h(\text{H})$ $t_h(\text{L})$	Hold time, High or Low $\bar{E}$ to CP	2	1.0 1.0	-0.9 -0.1	1.0 1.0	ns
$t_w(\text{H})$ $t_w(\text{L})$	Clock Pulse width High or Low	1	1.5 2.0	0.7 1.0	1.5 2.0	ns

## AC WAVEFORMS

$V_M = 1.5\text{V}$ ,  $V_{\text{IN}} = \text{GND to } 3.0\text{V}$

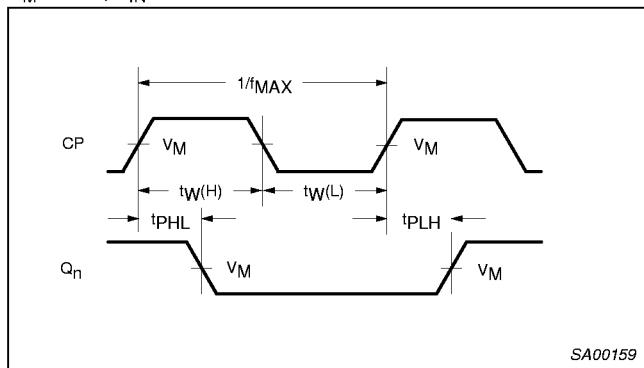

**Waveform 1. Propagation Delay, Clock Input to Output, Clock Pulse Width and Maximum Clock Frequency**

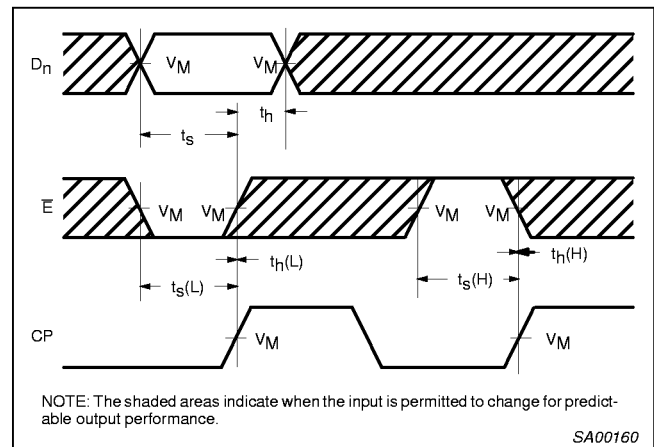

**Waveform 2. Data and Enable Setup and Hold Times**

# Octal D-type flip-flop with enable

## 74ABT377A

### TEST CIRCUIT AND WAVEFORM

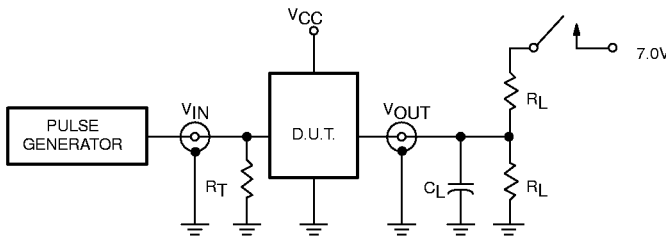

**Test Circuit for 3-State Outputs**

#### SWITCH POSITION

TEST	SWITCH
All	open

#### DEFINITIONS

- $R_L$  = Load resistor; see AC CHARACTERISTICS for value.
- $C_L$  = Load capacitance includes jig and probe capacitance; see AC CHARACTERISTICS for value.
- $R_T$  = Termination resistance should be equal to  $Z_{OUT}$  of pulse generators.

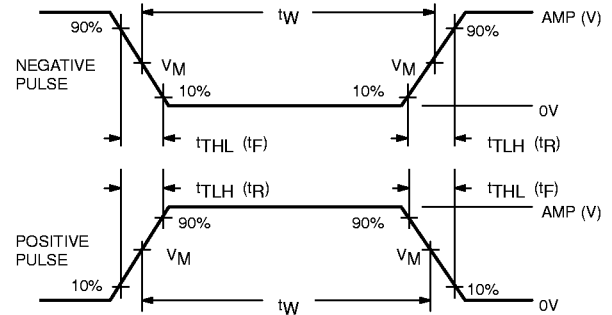

$V_M = 1.5V$

**Input Pulse Definition**

FAMILY	INPUT PULSE REQUIREMENTS				
	Amplitude	Rep. Rate	$t_W$	$t_R$	$t_F$
74ABT	3.0V	1MHz	500ns	2.5ns	2.5ns

SA00057

# Octal D-type flip-flop with enable

## 74ABT377A

DIP20: plastic dual in-line package; 20 leads (300 mil)

SOT146-1

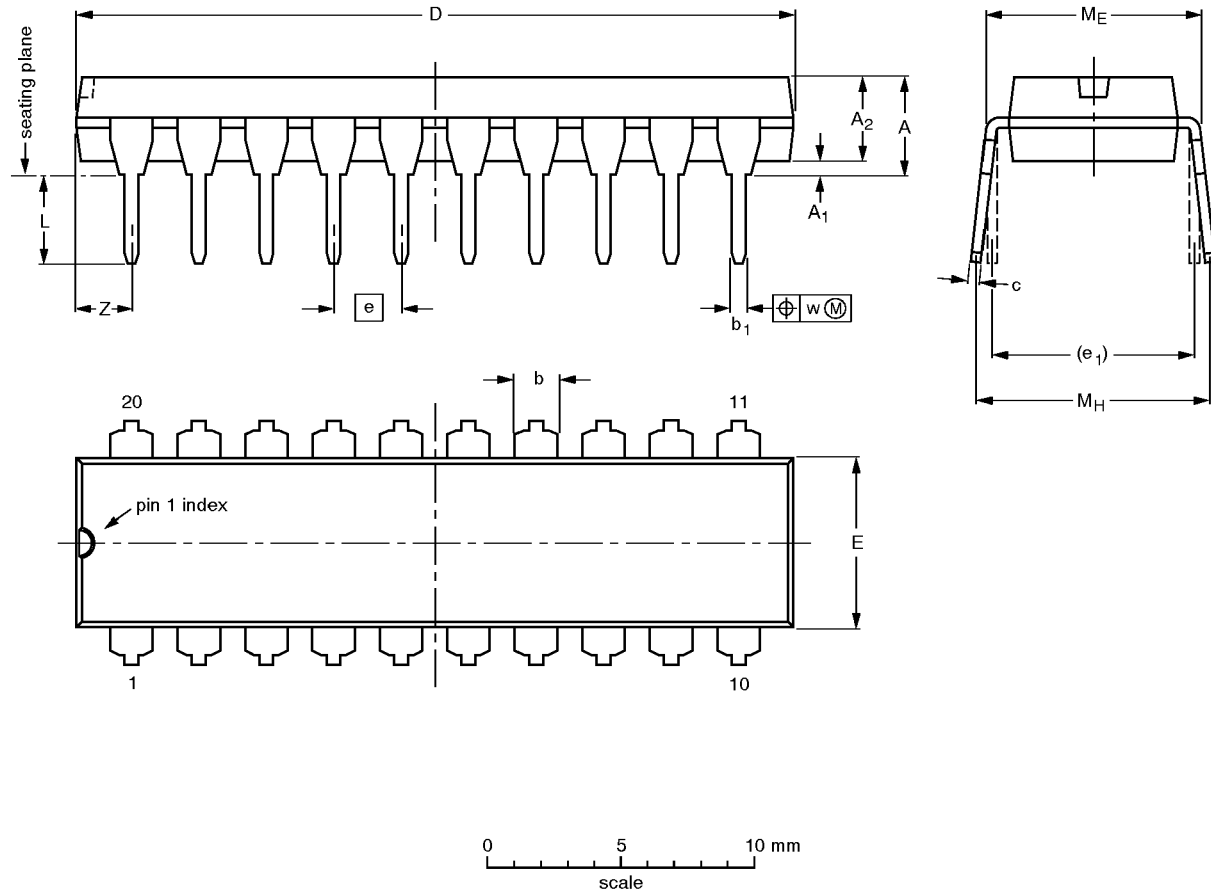

**DIMENSIONS (inch dimensions are derived from the original mm dimensions)**

UNIT	A max.	A <sub>1</sub> min.	A <sub>2</sub> max.	b	b <sub>1</sub>	c	D <sup>(1)</sup>	E <sup>(1)</sup>	e	e <sub>1</sub>	L	M <sub>E</sub>	M <sub>H</sub>	w	Z <sup>(1)</sup> max.
mm	4.2	0.51	3.2	1.73 1.30	0.53 0.38	0.36 0.23	26.92 26.54	6.40 6.22	2.54	7.62	3.60 3.05	8.25 7.80	10.0 8.3	0.254	2.0
inches	0.17	0.020	0.13	0.068 0.051	0.021 0.015	0.014 0.009	1.060 1.045	0.25 0.24	0.10	0.30	0.14 0.12	0.32 0.31	0.39 0.33	0.01	0.078

**Note**

1. Plastic or metal protrusions of 0.25 mm maximum per side are not included.

OUTLINE VERSION	REFERENCES				EUROPEAN PROJECTION	ISSUE DATE
	IEC	JEDEC	EIAJ			
SOT146-1			SC603			92-11-17 95-05-24

# Octal D-type flip-flop with enable

## 74ABT377A

**SO20: plastic small outline package; 20 leads; body width 7.5 mm**

**SOT163-1**

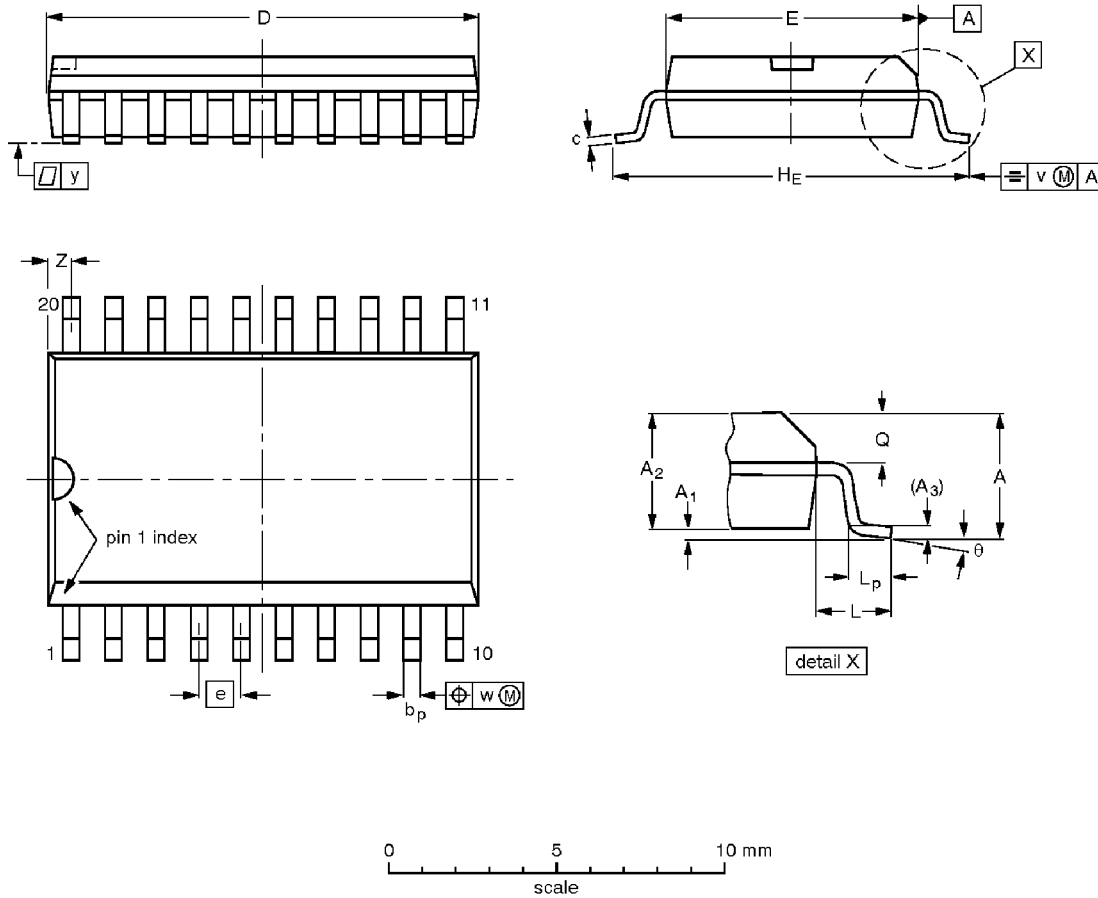

**DIMENSIONS (inch dimensions are derived from the original mm dimensions)**

UNIT	A max.	A <sub>1</sub>	A <sub>2</sub>	A <sub>3</sub>	b <sub>p</sub>	c	D <sup>(1)</sup>	E <sup>(1)</sup>	e	H <sub>E</sub>	L	L <sub>p</sub>	Q	v	w	y	Z <sup>(1)</sup>	θ
mm	2.65	0.30 0.10	2.45 2.25	0.25	0.49 0.36	0.32 0.23	13.0 12.6	7.6 7.4	1.27	10.65 10.00	1.4	1.1 0.4	1.1 1.0	0.25	0.25	0.1	0.9 0.4	8° 0°
inches	0.10	0.012 0.004	0.096 0.089	0.01	0.019 0.014	0.013 0.009	0.51 0.49	0.30 0.29	0.050	0.42 0.39	0.055	0.043 0.016	0.043 0.039	0.01	0.01	0.004	0.035 0.016	

**Note**

1. Plastic or metal protrusions of 0.15 mm maximum per side are not included.

OUTLINE VERSION	REFERENCES			EUROPEAN PROJECTION	ISSUE DATE
	IEC	JEDEC	EIAJ		
SOT163-1	075E04	MS-013AC			92-11-17 95-01-24



# Octal D-type flip-flop with enable

## 74ABT377A

**SSOP20: plastic shrink small outline package; 20 leads; body width 5.3 mm**

**SOT339-1**

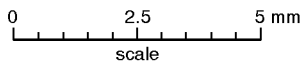
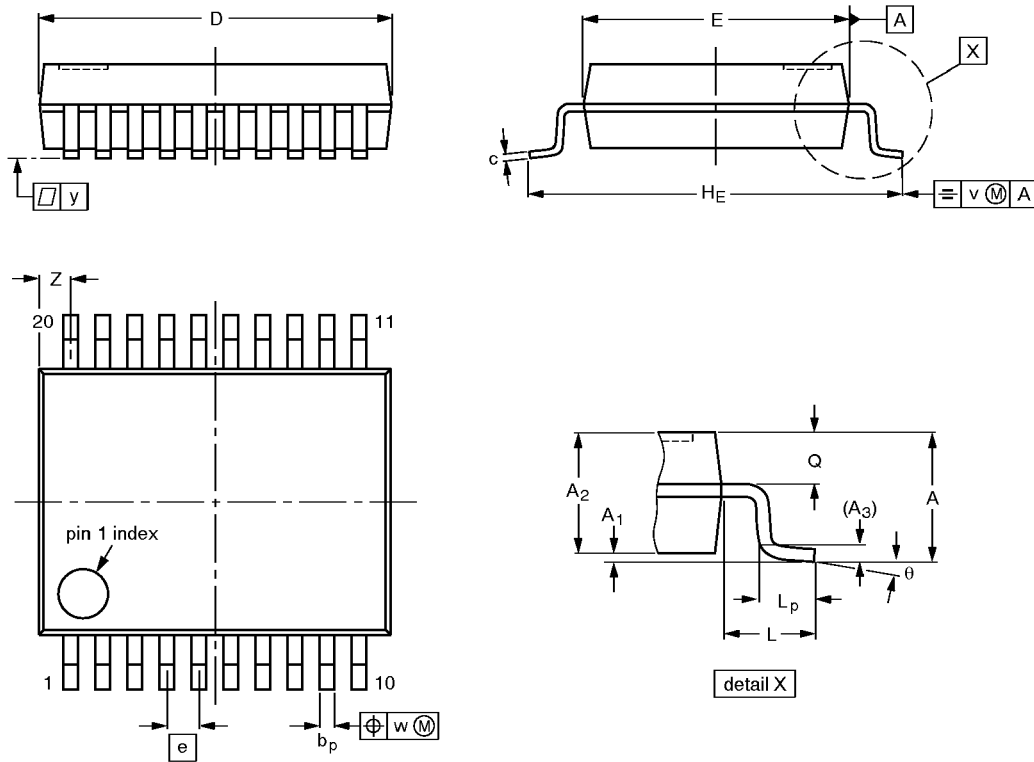

**DIMENSIONS (mm are the original dimensions)**

UNIT	A max.	A <sub>1</sub>	A <sub>2</sub>	A <sub>3</sub>	b <sub>p</sub>	c	D <sup>(1)</sup>	E <sup>(1)</sup>	e	H <sub>E</sub>	L	L <sub>p</sub>	Q	v	w	y	Z <sup>(1)</sup>	θ
mm	2.0	0.21 0.05	1.80 1.65	0.25	0.38 0.25	0.20 0.09	7.4 7.0	5.4 5.2	0.65	7.9 7.6	1.25	1.03 0.63	0.9 0.7	0.2	0.13	0.1	0.9 0.5	8° 0°

**Note**

1. Plastic or metal protrusions of 0.20 mm maximum per side are not included.

OUTLINE VERSION	REFERENCES				EUROPEAN PROJECTION	ISSUE DATE
	IEC	JEDEC	EIAJ			
SOT339-1		MO-150AE				93-09-08 95-02-04

# Octal D-type flip-flop with enable

## 74ABT377A

**TSSOP20: plastic thin shrink small outline package; 20 leads; body width 4.4 mm**

**SOT360-1**

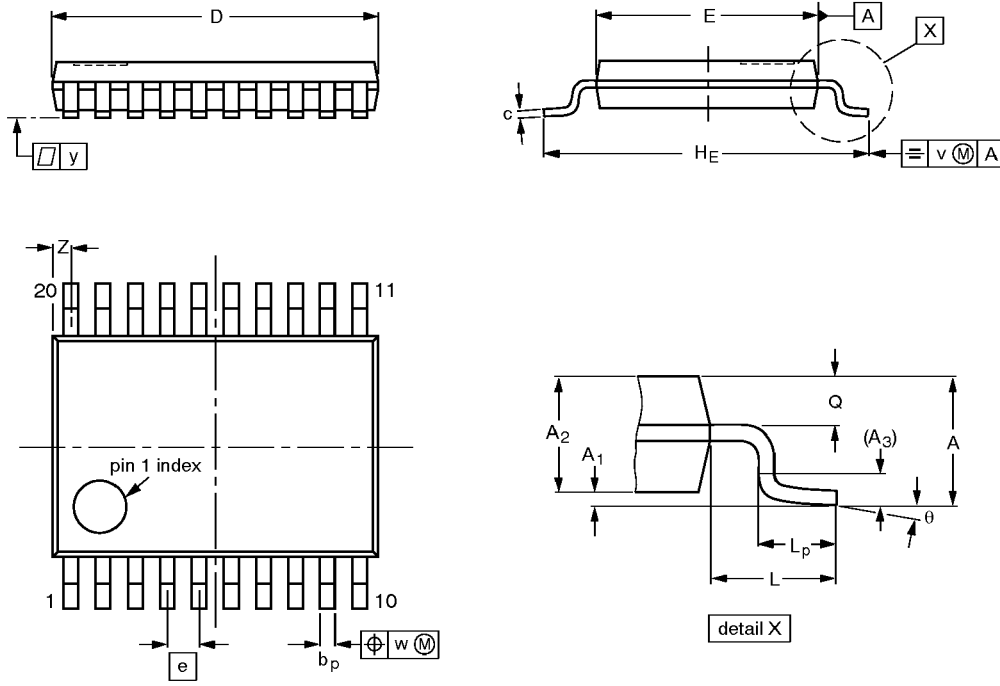

**DIMENSIONS (mm are the original dimensions)**

UNIT	A max.	A <sub>1</sub>	A <sub>2</sub>	A <sub>3</sub>	b <sub>p</sub>	c	D <sup>(1)</sup>	E <sup>(2)</sup>	e	H <sub>E</sub>	L	L <sub>p</sub>	Q	v	w	y	Z <sup>(1)</sup>	θ
mm	1.10	0.15 0.05	0.95 0.80	0.25	0.30 0.19	0.2 0.1	6.6 6.4	4.5 4.3	0.65	6.6 6.2	1.0	0.75 0.50	0.4 0.3	0.2	0.13	0.1	0.5 0.2	8° 0°

**Notes**

1. Plastic or metal protrusions of 0.15 mm maximum per side are not included.
2. Plastic interlead protrusions of 0.25 mm maximum per side are not included.

OUTLINE VERSION	REFERENCES				EUROPEAN PROJECTION	ISSUE DATE
	IEC	JEDEC	EIAJ			
SOT360-1		MO-153AC				-93-06-16 95-02-04