

FEATURES

- * SNAP MOUNTING.
- * MECHANICAL SWITCH REPLACEMENT.
- * THREE WIRES FOR ELECTRICAL CONNECTION.
- * CUSTOMIZED LEVER ARM CAN BE DESIGNED FOR SPECIFIC APPLICATION.

PACKAGE DIMENSIONS

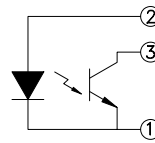
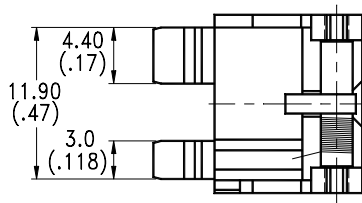

PIN NO.	SIGN	COLOR
1	GROUND	BLACK
2	ANODE	RED
3	COLLECTOR	BLUE

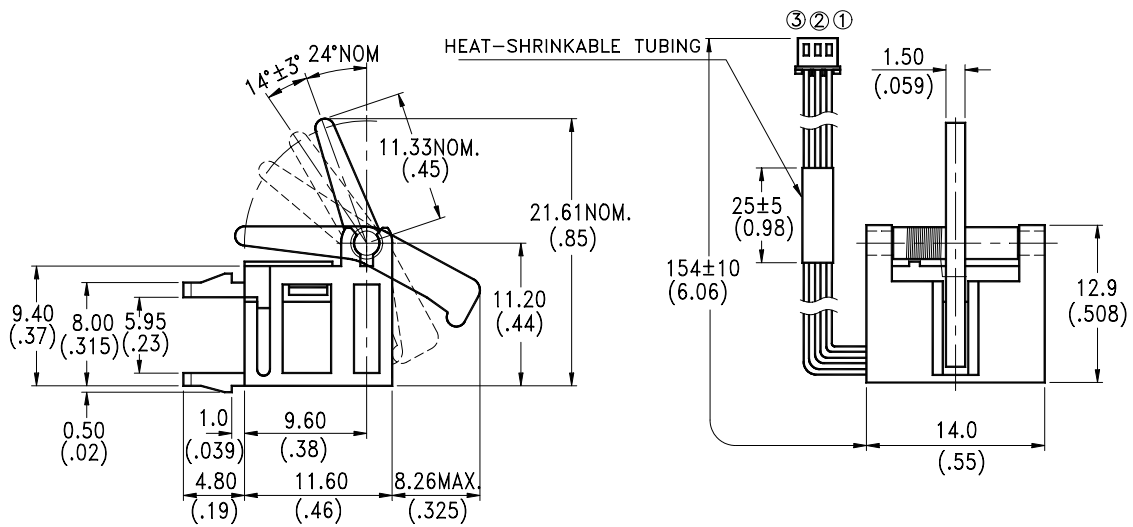

NOTES:

1. All dimensions are in millimeters (inches).
2. Tolerance is $\pm 0.25\text{mm} (.010\text{'})$ unless otherwise noted.



ABSOLUTE MAXIMUM RATINGS AT TA=25°C

PARAMETER	SYMBOL	MAXIMUM RATING	UNIT
INPUT LED			
Power Dissipation	P_D	75	mW
Peak Forward Current (300 pps , 10 μ S pulse)	I_{CP}	1	A
Continuous Forward Current	I_F	50	mA
Reverse Voltage	V_R	5	V
OUTPUT PHOTOTRANSISTOR			
Power Dissipation	P_C	100	mW
Collector-Emitter Voltage	V_{CEO}	30	V
Emitter-Collector Voltage	V_{ECO}	5	V
Collector Current	I_C	20	mA
Operating Temperature Range	T_{opr}	-25°C to + 85°C	
Storage Temperature Range	T_{stg}	-55°C to + 100°C	



ELECTRICAL OPTICAL CHARACTERISTICS AT TA=25°C

PARAMETER	SYMBOL	MIN.	TYP.	MAX.	UNIT	TEST CONDITION
INPUT LED						
Forward Voltage	V_F		1.2	1.6	V	$I_F = 20\text{mA}$
Reverse Current	I_R			100	μA	$V_R = 5\text{V}$
OUTPUT PHOTOTRANSISTOR						
Collector-Emitter Dark Current	I_{CEO}			100	nA	$V_{CE} = 10\text{V}$
COUPLER						
Collector-Emitter Saturation Voltage	$V_{CE(SAT)}$			0.4	V	$I_C = 0.25\text{mA}$ $I_F = 20\text{mA}$
On State Collector Current	$I_{C(ON)}$	0.5	2.0		mA	$V_{CE} = 5\text{V}$ $I_F = 20\text{mA}$
Response Time	Rise Time	T_R		3	15	μS $V_{CE} = 5\text{V}, I_C = 2\text{mA}$ $R_L = 100 \Omega$
	Fall Time	T_F		4	20	

TYPICAL ELECTRICAL / OPTICAL CHARACTERISTICS CURVES

(25°C Ambient Temperature Unless Otherwise Noted)

Fig.1 Power Dissipation vs. Ambient Temperature

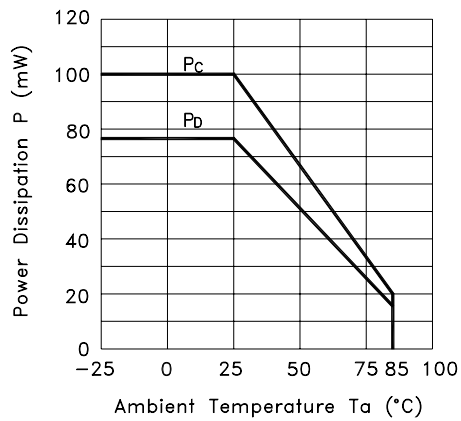

Fig.2 Forward Current vs. Forward Voltage

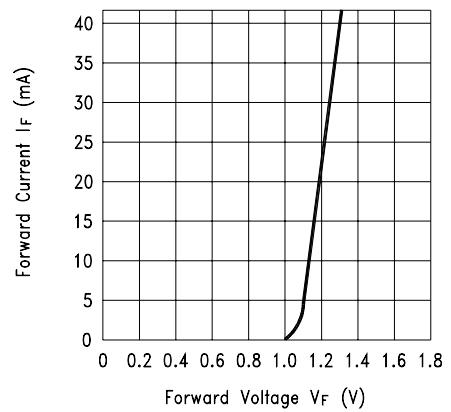

Fig.3 Collector Current vs. Forward Voltage

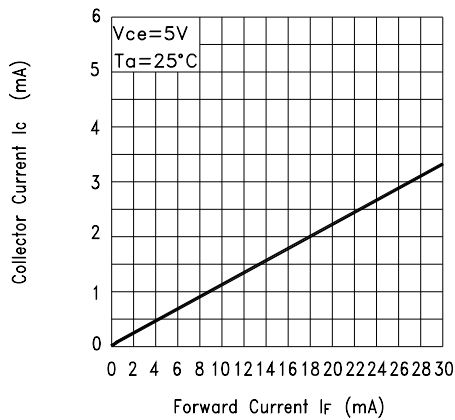
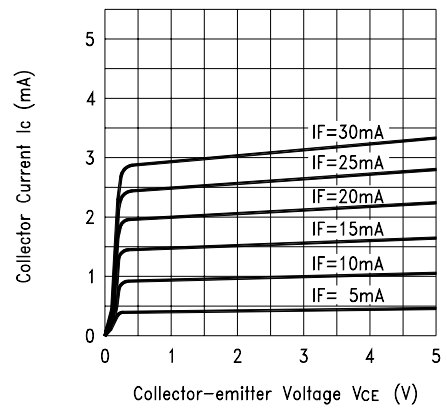

Fig.4 Collector Current vs. Collector-emitter Voltage



TYPICAL ELECTRICAL / OPTICAL CHARACTERISTICS CURVES

(25°C Ambient Temperature Unless Otherwise Noted)

Fig.5 Collector Current vs. Ambient Temperature

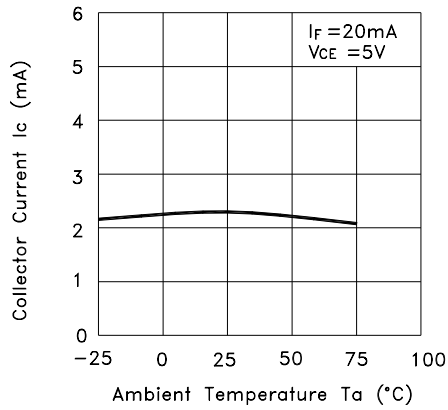

Fig.6 Collector-emitter Saturation Voltage vs. Ambient Temperature

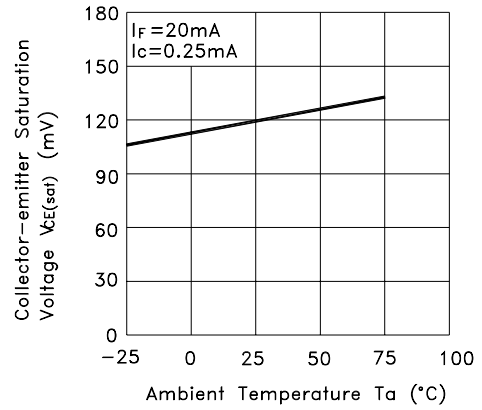
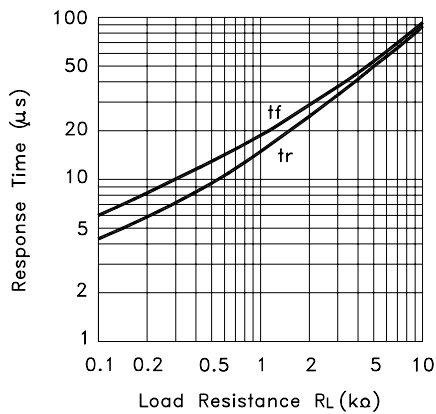

Fig.7 Response Time vs. Load Resistance



Test Circuit for Response Time

