

DO NOT SCALE FROM THIS PRINT

No OF POSITIONS
-04 THRU -30

OPTIONS
-TR: TAPE AND REEL

LEAD STYLE
-01: CONTACT BOTTOM
-02: CONTACT TOP
-03: TOP ENTRY (SEE SHEET 3)

WELD TAB

PLATING SPECIFICATION
-T: TIN (.000120 MIN TIN OVER
.000040 MIN NICKEL)
(TIN/LEAD RATIO IS 9/1)
[D]-TM: PURE TIN, MATTE FINISH

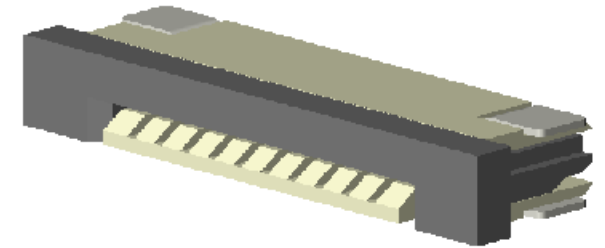
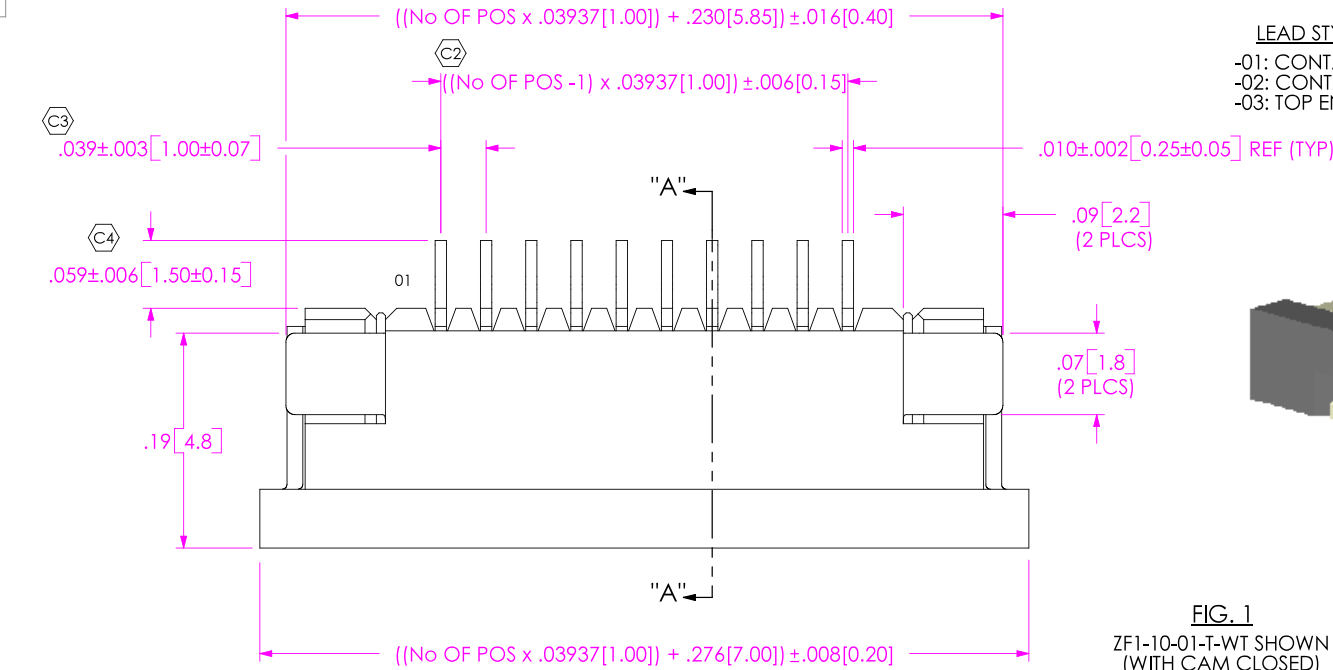
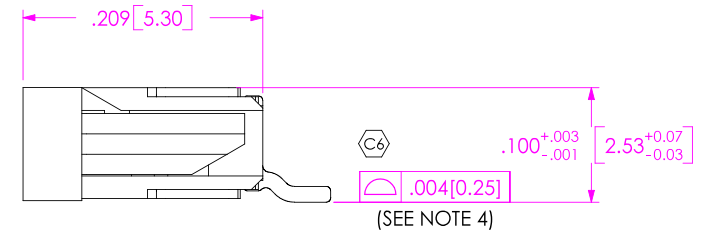
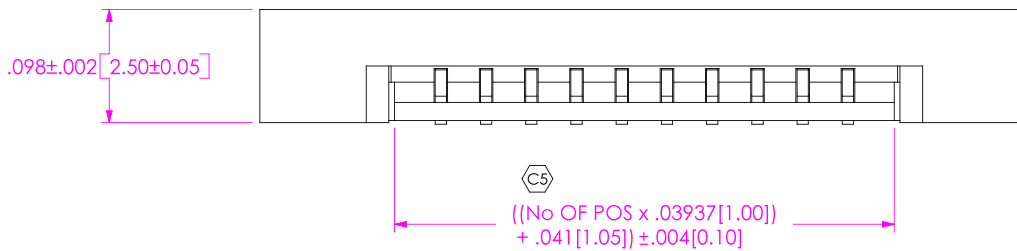

FIG. 1
ZF1-10-01-T-WT SHOWN
(WITH CAM CLOSED)



NOTES:

1. © REPRESENTS A CRITICAL DIMENSION.
2. BURR ALLOWANCE: .0010[0.25] MAXIMUM.
3. CONTACT; MINIMUM PUSHOUT FORCE: 6 OZ.
4. COPLANARITY INCLUDES TAILS AND WELD TABS.
5. WELD TAB RETENTION: 12 OZ.
6. BREAKOFF BURR NOT TO EXCEED .007[0.18] & MUST REMAIN ATTACHED.

UNLESS OTHERWISE SPECIFIED, DIMENSIONS ARE IN INCHES.
TOLERANCES ARE:
DECIMALS ANGLES
.XX: ±.014[0.35]
.XXX: ±.008[0.20]
.XXXX: ±.0005[0.125]

PROPRIETARY NOTE

THIS DOCUMENT CONTAINS INFORMATION CONFIDENTIAL AND PROPRIETARY TO SAMTEC, INC. AND SHALL NOT BE REPRODUCED OR TRANSFERRED TO OTHER DOCUMENTS OR DISCLOSED TO OTHERS OR USED FOR ANY PURPOSE OTHER THAN THAT WHICH IT WAS OBTAINED WITHOUT THE EXPRESSED WRITTEN CONSENT OF SAMTEC, INC.

MATERIAL: DO NOT SCALE DRAWING
HOUSING: LCP, COLOR: NATURAL
CAM SLIDER: PPS, COLOR: BLACK
CONTACT & WELD TAB:
PHOS BRONZE
MAX FLASH ALLOWED: .002
MAX GATE VESTIGE: .002
F:\DWG\MISC\MKTG\ZF1-XX-XX-XX-WT-DEAN.SLDDRW



SHEET SCALE: 6:1

SAMTEC

520 PARK EAST BLVD, NEW ALBANY, IN 47150
PHONE: 812.944.6733 FAX: 812.948.5047
e-Mail: INFO@SAMTEC.COM CODE: 55322

DESCRIPTION:
ZERO INSERTION FORCE 1mm ASSEMBLY

DWG. NO. ZF1-XX-XX-XX-WT-XX-DEAN

BY: KEVIN B 9/20/2002 SHEET 1 OF 3

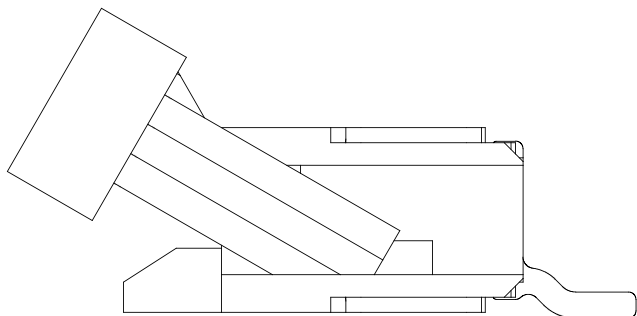

-01 LEAD STYLE [CONTACT BOTTOM]
(WITH CAM OPEN)

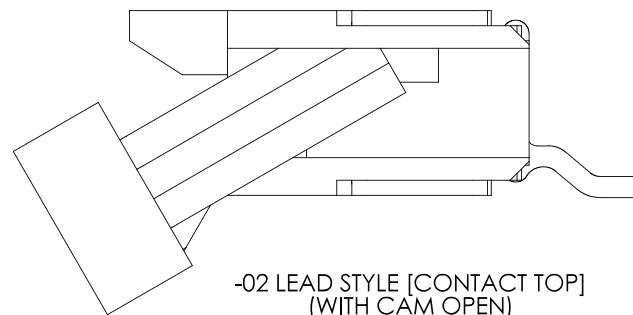

-02 LEAD STYLE [CONTACT TOP]
(WITH CAM OPEN)

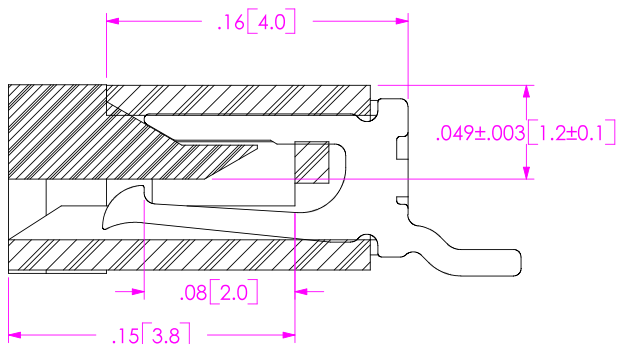

SECTION "A"-"A"
-01 LEAD STYLE
(WITH CAM CLOSED)

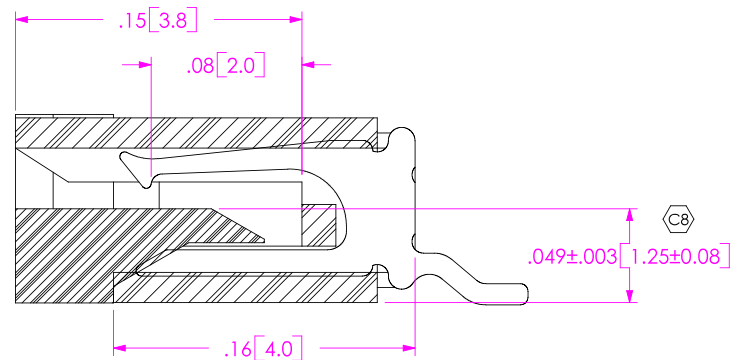

SECTION "A"-"A"
-02 LEAD STYLE
(WITH CAM CLOSED)

PACKAGING VIEWS

[PARTS TO HAVE POSITION #1 LOADED IN
SAME DIRECTION AS ARROW ON TUBE]

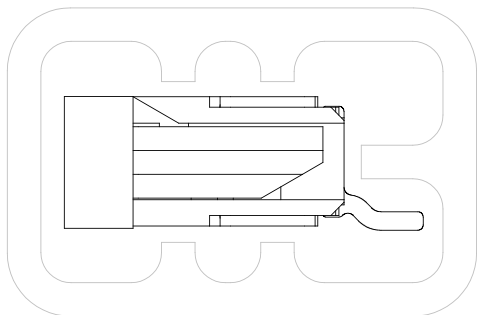

-01 & -02 LEAD STYLE:
TUBE: PT-1-24-02-117
PLUG: TP-24

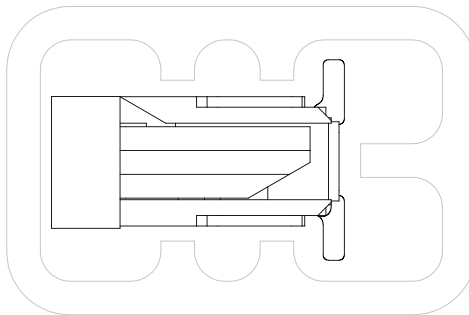

-03 LEAD STYLE:
TUBE: PT-1-24-02-117
PLUG: TP-24

PROPRIETARY NOTE

THIS DOCUMENT CONTAINS INFORMATION
CONFIDENTIAL AND PROPRIETARY TO
SAMTEC, INC. AND SHALL NOT BE REPRODUCED
OR TRANSFERRED TO OTHER DOCUMENTS OR
DISCLOSED TO OTHERS OR USED FOR ANY
PURPOSE OTHER THAN THAT WHICH IT WAS
OBTAINED WITHOUT THE EXPRESSED WRITTEN
CONSENT OF SAMTEC, INC.

DO NOT SCALE DRAWING

SHEET SCALE: 10:1

F:\DWG\MISC\MKTG\ZF1-XX-XX-XX-WT-DEAN.SLDDRW

SAMTEC

520 PARK EAST BLVD, NEW ALBANY, IN 47150
PHONE: 812.944.6733 FAX: 812.948.5047
e-Mail: INFO@SAMTEC.COM CODE: 55322

DESCRIPTION:
ZERO INSERTION FORCE 1mm ASSEMBLY

DWG. NO. **ZF1-XX-XX-XX-WT-XX-DEAN**

BY: KEVIN B 9/20/2002 SHEET 2 OF 3

FIG. 2
 -03 LEAD STYLE
 (SAME AS FIG. 1, UNLESS OTHERWISE STATED)
 (ZF1-10-03-T-WT SHOWN)

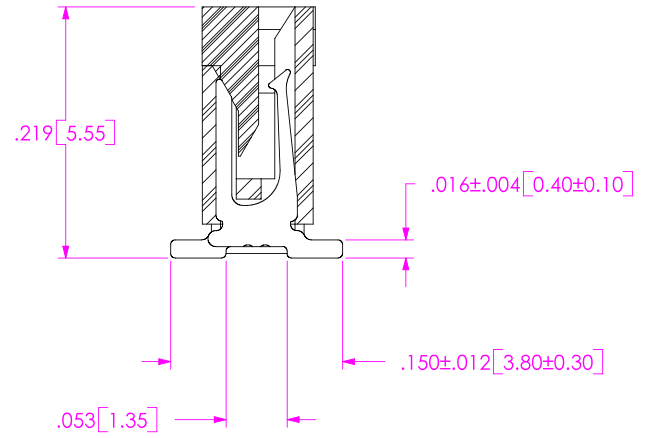
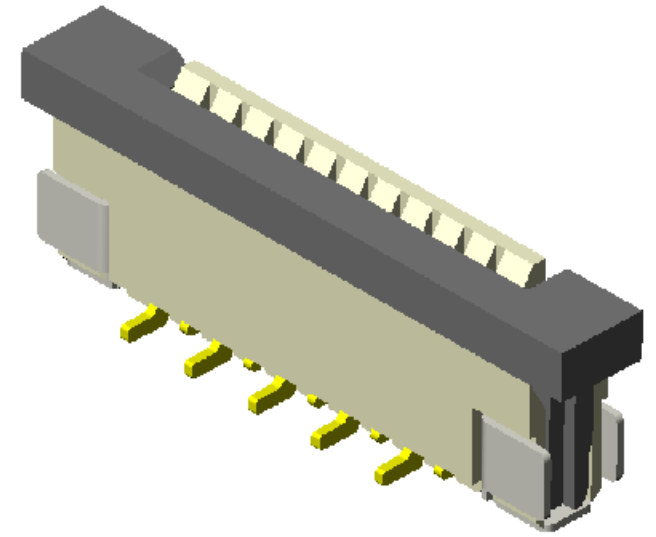
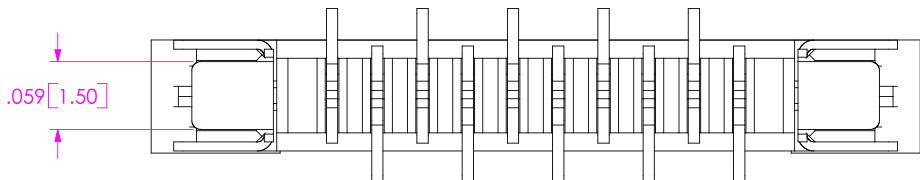
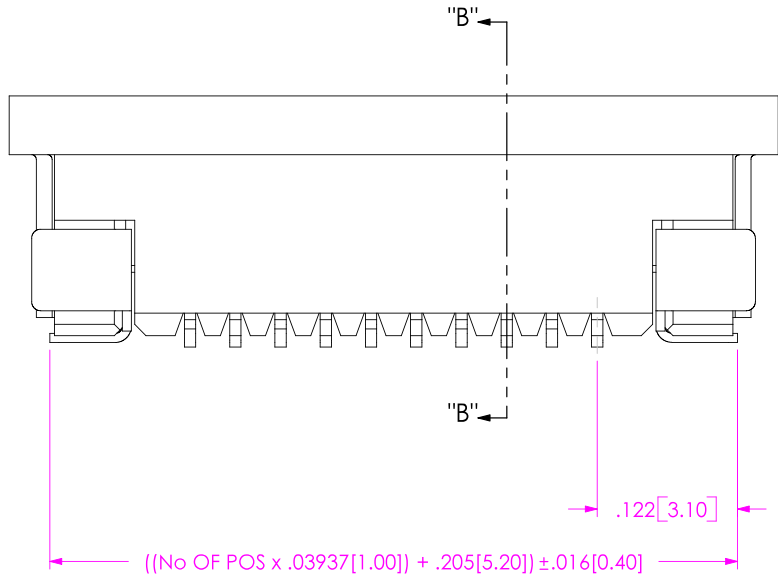
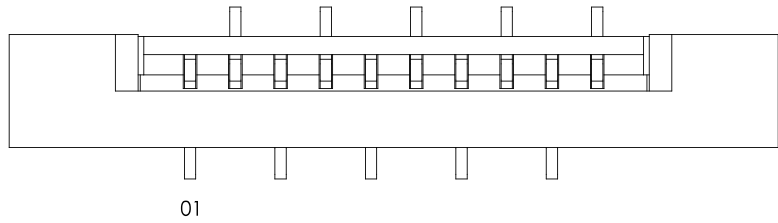

SECTION "B"- "B"

PROPRIETARY NOTE

THIS DOCUMENT CONTAINS INFORMATION CONFIDENTIAL AND PROPRIETARY TO SAMTEC, INC. AND SHALL NOT BE REPRODUCED OR TRANSFERRED TO OTHER DOCUMENTS OR DISCLOSED TO OTHERS OR USED FOR ANY PURPOSE OTHER THAN THAT WHICH IT WAS OBTAINED WITHOUT THE EXPRESSED WRITTEN CONSENT OF SAMTEC, INC.

DO NOT SCALE DRAWING

SHEET SCALE: 6:1

SAMTEC

520 PARK EAST BLVD, NEW ALBANY, IN 47150
 PHONE: 812.944.6733 FAX: 812.948.5047
 e-Mail: INFO@SAMTEC.COM CODE: 55322

DESCRIPTION:
 ZERO INSERTION FORCE 1mm ASSEMBLY

DWG. NO. ZF1-XX-XX-XX-WT-XX-DEAN

BY: KEVIN B 9/20/2002 SHEET 3 OF 3