

DATA SHEET

THIN FILM CHIP RESISTORS

High precision - high stability

RT series

0.05% TO 1%, TC 10 TO 50

sizes 0402/0603/0805/1206/
1210/2010/2512

RoHS compliant



SCOPE

This specification describes RT0402 to RT2512 high precision - high stability chip resistors with lead-free terminations made by thin film process.

APPLICATIONS

- Converters
- Printer equipment
- Server board
- Telecom
- Consumer

FEATURES

- RoHS compliant
 - Products with lead free terminations meet RoHS requirements
 - Pb-glass contained in electrodes
 - Resistor element and glass are exempted by RoHS
- Reducing environmentally hazardous wastes
- High component and equipment reliability
- Saving of PCB space
- None forbidden-materials used in products/production
- Halogen Free Epoxy

ORDERING INFORMATION - GLOBAL PART NUMBER & I2NC

Both part numbers are identified by the series, size, tolerance, packing type, temperature coefficient, taping reel and resistance value.

YAGEO BRAND ordering code

GLOBAL PART NUMBER (PREFERRED)

RT XXXX F X X XX XXXX L
 (1) (2) (3) (4) (5) (6) (7)

(1) SIZE

0402 / 0603 / 0805 / 1206 / 1210 / 2010 / 2512

(2) TOLERANCE

W = ±0.05%
 B = ±0.1%
 C = ±0.25%
 D = ±0.5%
 F = ±1%

(3) PACKAGING TYPE

R = Paper/PE taping reel K = Embossed taping reel

(4) TEMPERATURE COEFFICIENT OF RESISTANCE

B = 10 ppm/°C C = 15 ppm/°C D = 25 ppm/°C E = 50 ppm/°C

(5) TAPING REEL

07 = 7 inch dia. Reel 10 = 10 inch dia. Reel 13 = 13 inch dia. Reel

(6) RESISTANCE VALUE

There are 2~4 digits indicated the resistor value. Letter R/K/M is decimal point, no need to mention the last zero after R/K/M, e.g.1K2, not 1K20.

Detailed resistance rules show in table of "Resistance rule of global part number".

(7) OPTIONAL CODE

L = optional symbol ^(Note)

Resistance rule of global part number

Resistance code rule	Example
XRXX (1 to 9.76 Ω)	1R = 1 Ω 1R5 = 1.5 Ω 9R76 = 9.76 Ω
XXRX (10 to 97.6 Ω)	10R = 10 Ω 97R6 = 97.6 Ω
XXXXR (100 to 976 Ω)	100R = 100 Ω
XKXX (1 to 9.76 KΩ)	1K = 1,000 Ω 9K76 = 9760 Ω
XMXX (1 to 9.76 MΩ)	1M = 1,000,000 Ω 9M76 = 9,760,000 Ω

ORDERING EXAMPLE

The ordering code of a RT0603 chip resistor, TC 50 value 56 Ω with ±0.5% tolerance, supplied in 7-inch tape reel is: RT0603DRE0756R(L).

NOTE

1. All our RSMD products meet RoHS compliant. "LFP" of the internal 2D reel label mentions "Lead Free Process"
2. On customized label, "LFP" or specific symbol printed and the optional "L" at the end of GLOBAL PART NUMBER / I2NC can be added (both are on customer request)

PHYCOMP BRAND ordering codes

Both GLOBAL PART NUMBER (preferred) and I2NC (traditional) codes are acceptable to order Phycomp brand products. For matching traditional types with size codes, please refer to “Comparison table of traditional types and sizes”.

GLOBAL PART NUMBER (PREFERRED)

For detailed information of GLOBAL PART NUMBER and ordering example, please refer to page 2.

I2NC CODE

2390 (1)	X (2)	XX (3)	X (4)	XXXX (5)	L (6)
START WITH (1)	TCR (2) (ppm/°C)	PACKING CODE BY SIZE (inch) (3)	TOL. (4) (%)	RESISTANCE RANGE	SYMBOL (NOTE)
2390	8 = ±10 7 = ±15 6 = ±25 4 = ±50	0402: 07 = 7" reel 27 = 10" reel 47 = 13" reel 0603: 04 = 7" reel 24 = 10" reel 44 = 13" reel 0805: 01 = 7" reel 21 = 10" reel 41 = 13" reel 1206: 11 = 7" reel 31 = 10" reel 51 = 13" reel 1210: 12 = 7" reel 32 = 10" reel 52 = 13" reel 2010: 15 = 7" reel 2512: 18 = 7" reel	7 = ±1 6 = ±0.5 5 = ±0.25 4 = ±0.1 3 = ±0.05	The remaining 4 digits represent the resistance value with the last digit indicating the multiplier as shown in the table of "Last digit of I2NC". 0402: 10Ω ≤ R < 121KΩ 0603: 5.1 Ω ≤ R ≤ 681 KΩ 0805: 5.1Ω ≤ R ≤ 1.5 MΩ 1206: 5.1Ω ≤ R ≤ 1.5 MΩ 2010: 10Ω ≤ R ≤ 1 MΩ 2512: 10Ω ≤ R ≤ 1 MΩ	"L" is optional symbol.

Exceptions to above packing code definitions:

- 0805 TC50 with 1%, supplied in 13" reel, the packing code is 02.
- 0603 TC50 with 1%, supplied in 13" reel, the packing code is 03.
- 2512 TC15, in 7" reel, the packing code is 35.
- 2010 TC15, in 7" reel, the packing code is 31.

ORDERING EXAMPLE

The ordering code of a TF221 resistor, TC50, value 56 Ω, with ±0.5% tolerance, supplied in tape of 5,000 units per reel is: 239040465609(L) or RT0603DRE0756R(L).

NOTE

- All our RSMD products are RoHS compliant. "LFP" of the internal 2D reel label mentions "Lead Free Process"
- On customized label, "LFP" or specific symbol printed and the optional "L" at the end of GLOBAL PART NUMBER / I2NC can be added (both are on customer request)

Comparison table of traditional types and sizes

TF (1)	X (2)	X (3)	X (4)
START WITH	SIZE CODE	TCR (ppm/°C)	TOL (%)
TF	3 = 0402 2 = 0603 1 = 0805 0 = 1206 5 = 1210 7 = 2010 6 = 2512	4 = ±10 3 = ±15 1 = ±25 2 = ±50	0 = ±1 1 = ±0.5 2 = ±0.25 3 = ±0.1 4 = ±0.05

Example:

TF321 = RT0402, TC50, ±0.5% tolerance

Resistance decade (3)	Last digit
1 to 9.76 Ω	8
10 to 97.6 Ω	9
100 to 976 Ω	1
1 to 9.76 kΩ	2
10 to 97.6 kΩ	3
100 to 976 kΩ	4
1 to 9.76 MΩ	5
10 to 97.6 MΩ	6

Example: 1 Ω = 1008 or 108
33 kΩ = 3303 or 333
10 MΩ = 1006 or 106

MARKING

RT0805 / RT1206 / RT1210 / RT2010 / RT2512

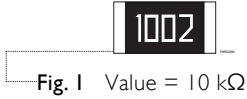

Either resistance in E-24 or E-96: 4 digits
First three digits for significant figure and 4th digit for number of zeros

RT0603



E-24 series: 3 digits
First two digits for significant figure and 3rd digit for number of zeros



E-96 series: 3 digits for 0603±1% EIA-96 marking method

RT0402 / RESISTANCE VALUE IS NOT IN E-24 / E96 SERIES



No marking

For further marking information, please see special data sheet “Chip resistors marking”.

CONSTRUCTION

The resistors are constructed out of a high-grade ceramic body. Internal metal electrodes are added at each end and connected by a resistive layer. The resistive layer is adjusted to give the approximate required resistance and laser cutting of this resistive layer that achieves tolerance trims the value. The resistive layer is covered with a protective coat and printed with the resistance value. Finally, the two external terminations (matte tin) are added. See fig. 5.

DIMENSION

Table I For outlines see fig. 5

TYPE	L (mm)	W (mm)	H (mm)	l ₁ (mm)	l ₂ (mm)
RT0402	1.00 ±0.10	0.50 ±0.05	0.30 ±0.05	0.20 ±0.10	0.25 ±0.10
RT0603	1.60 ±0.10	0.80 ±0.10	0.45 ±0.10	0.25 ±0.15	0.25 ±0.15
RT0805	2.00 ±0.10	1.25 ±0.10	0.50 ±0.10	0.35 ±0.20	0.35 ±0.20
RT1206	3.10 ±0.10	1.60 ±0.10	0.55 ±0.10	0.45 ±0.20	0.40 ±0.20
RT1210	3.10 ±0.10	2.60 ±0.15	0.55 ±0.10	0.50 ±0.20	0.50 ±0.20
RT2010	5.00 ±0.10	2.50 ±0.15	0.55 ±0.10	0.60 ±0.20	0.50 ±0.20
RT2512	6.35 ±0.10	3.20 ±0.15	0.55 ±0.10	0.60 ±0.20	0.50 ±0.20

OUTLINES

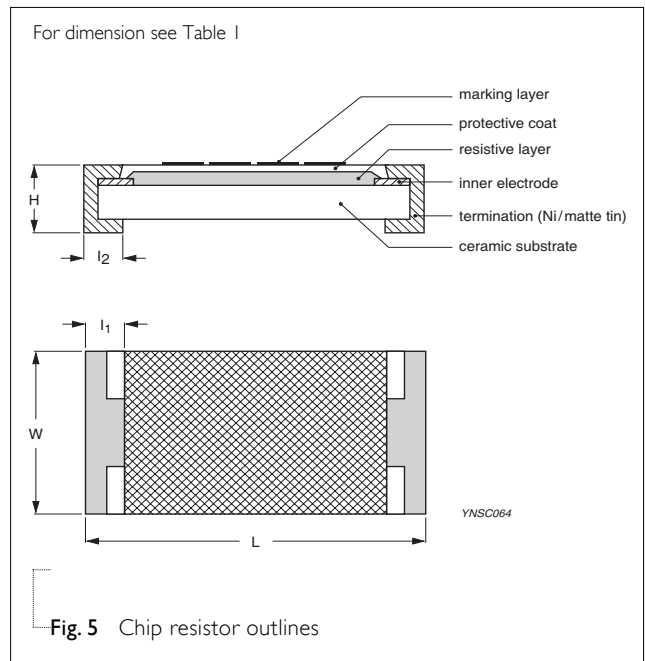

Fig. 5 Chip resistor outlines

ELECTRICAL CHARACTERISTICS

Table 2

TYPE	Operating Temperature Range	Power Rating	Max. Work Vol. ⁽¹⁾	Max. Overload Vol.	Dielectric Withstand Vol.	T.C.R. (ppm/°C)	Resistance Range (E-24/E-96 series) ⁽²⁾ & Tolerance					
							±0.05%	±0.1%	±0.25%	±0.5%	±1.0%	
RT0402	-55 °C to +125 °C	1/16W	50V	100V	75V	±50	---	10~121k	10~121k	10~121k	10~121k	
							±25	---	10~121k	10~121k	10~121k	---
							±15	---	10~100k	10~100k	---	---
							±10	---	10~100k	10~100k	---	---
RT0603	-55 °C to +125 °C	1/10W	75V	150V	100V	±50	---	10~681k	1~681k	1~681k	1~681k	
							±25	1k~47k	10~681k	10~681k	10~681k	---
							±15	1k~47k	10~100k	10~100k	---	---
							±10	1k~47k	10~100k	10~100k	---	---
RT0805	-55 °C to +125 °C	1/8W	150V	300V	200V	±50	---	10~1.5M	1~1.5M	1~1.5M	1~1.5M	
							±25	100~100k	10~1.5M	10~1.5M	10~1.5M	---
							±15	100~100k	10~100k	10~100k	---	---
							±10	100~100k	10~100k	10~100k	---	---
RT1206	-55 °C to +125 °C	1/8W	200V	400V	300V	±50	---	10~1.5M	1~1.5M	1~1.5M	1~1.5M	
							±25	100~100k	10~1.5M	10~1.5M	10~1.5M	---
							±15	100~100k	10~100k	10~100k	---	---
							±10	100~100k	10~100k	10~100k	---	---
RT1210	-55 °C to +125 °C	1/4W	200V	400V	400V	±50	---	10~1M	1~1M	1~1M	1~1M	
							±25	100~100k	10~1M	10~1M	10~1M	---
							±15	100~100k	10~100k	10~100k	---	---
							±10	100~100k	10~100k	10~100k	---	---
RT2010	-55 °C to +125 °C	1/2W	200V	400V	400V	±50	---	10~1M	10~1M	10~1M	10~1M	
							±25	100~100k	10~1M	10~1M	10~1M	---
							±15	100~100k	10~100k	10~100k	---	---
							±10	100~100k	10~100k	10~100k	---	---
RT2512	-55 °C to +125 °C	3/4W	200V	400V	400V	±50	---	10~1M	10~1M	10~1M	10~1M	
							±25	100~100k	10~1M	10~1M	10~1M	---
							±15	100~100k	10~100k	10~100k	---	---
							±10	100~100k	10~100k	10~100k	---	---

NOTES

1. The maximum working voltage that may be continuously applied to the resistor element, see "IEC publication 60115-8"
2. Value of E-192 series is on request

FOOTPRINT AND SOLDERING PROFILES

For recommended footprint and soldering profiles, please see the special data sheet “Chip resistors mounting”.

PACKING STYLE AND PACKAGING QUANTITY

Table 3 Packing style and packaging quantity

PACKING STYLE	REEL DIMENSION	RT0402	RT0603	RT0805	RT1206	RT1210	RT2010	RT2512
Paper/PE taping reel (R)	7" (178 mm)	10,000	5,000	5,000	5,000	5,000	---	---
	10" (254 mm)	20,000	10,000	10,000	10,000	10,000	---	---
	13" (330 mm)	50,000	20,000	20,000	20,000	20,000	---	---
Embossed taping reel (K)	7" (178 mm)	---	---	---	---	---	4,000	4,000

NOTE

1. For Paper/Embossed tape and reel specification/dimensions, please see the special data sheet “Packing” document.

FUNCTIONAL DESCRIPTION

POWER RATING

Each type rated power at 70°C:
 RT0402=1/16 W, RT0603=1/10 W, RT0805=1/8 W,
 RT1206=1/8 W, RT1210=1/4 W, RT2010=1/2 W,
 RT2512=3/4 W.

RATED VOLTAGE

The DC or AC (rms) continuous working voltage corresponding to the rated power is determined by the following formula:

$V = \sqrt{P \times R}$
 or max. working voltage whichever is less

Where

V=Continuous rated DC or AC (rms) working voltage (V)

P=Rated power (W)

R=Resistance value (Ω)

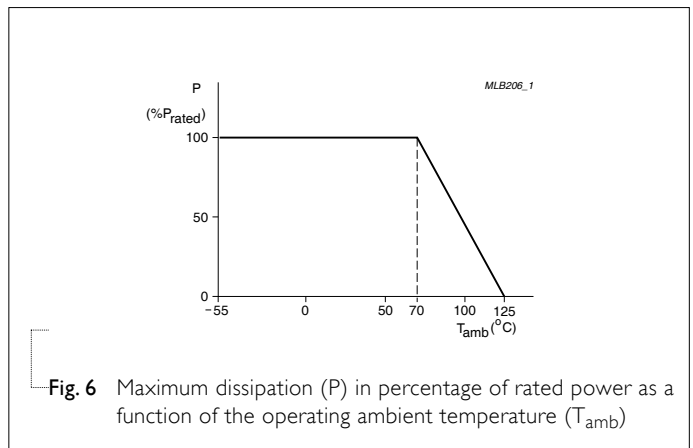

Fig. 6 Maximum dissipation (P) in percentage of rated power as a function of the operating ambient temperature (T_{amb})

TESTS AND REQUIREMENTS
Table 4 Test condition, procedure and requirements

TEST	TEST METHOD	PROCEDURE	REQUIREMENTS
Life/ Operational Life/ Endurance	MIL-STD-202G-method 108A	1,000 hours at 70±5 °C applied RCWV	±(0.5%+0.05 Ω)
	IEC 60115-1 4.25.1	1.5 hours on, 0.5 hour off, still air required	
	JIS C 5202-7.10		
High Temperature Exposure/ Endurance at upper category temperature	MIL-STD-202G-method 108A	1,000 hours at maximum operating temperature	±(0.5%+0.05 Ω)
	IEC 60115-1 4.25.3	depending on specification, unpowered	
	JIS C 5202-7.11	No direct impingement of forced air to the parts Tolerances: 125±3 °C	
Moisture Resistance	MIL-STD-202G-method 106F	Each temperature / humidity cycle is defined at 8 hours (method 106F), 3 cycles / 24 hours for 10d with 25 °C / 65 °C 95% R.H, without steps 7a & 7b, unpowered Parts mounted on test-boards, without condensation on parts Measurement at 24±2 hours after test conclusion	±(0.5%+0.05 Ω)
	IEC 60115-1 4.24.2		
Thermal Shock	MIL-STD-202G-method 107G	-55/+125 °C Note: Number of cycles required is 300. Devices unmounted Maximum transfer time is 20 seconds. Dwell time is 15 minutes. Air – Air	±(0.5%+0.05Ω) for 10 KΩ to 10 MΩ ±(0.5%+0.05Ω) for others
Short time overload	MIL-R-55342D-para 4.7.5 IEC60115-1 4.13	2.5 times RCWV or maximum overload voltage whichever is less for 5 sec at room temperature	±(0.5%+0.05Ω) No visible damage
Board Flex/ Bending	IEC60115-1 4.33	Device mounted on PCBoard as described, only 1 board bending required 3 mm bending Bending time: 60±5 seconds Ohmic value checked during bending	±(0.5%+0.05Ω) No visible damage

TEST	TEST METHOD	PROCEDURE	REQUIREMENTS
Solderability - Wetting	IPC/JEDECJ-STD-002B test B IEC 60068-2-58	Electrical Test not required. Magnification 50X. SMD conditions: 1 st step: method B, aging 4 hours at 155°C dry heat 2 nd step: leadfree solder bath at 245±3°C Dipping time: 3±0.5 seconds	Well tinned (≥95% covered) No visible damage
- Leaching	IPC/JEDECJ-STD-002B test D IEC 60068-2-58	Leadfree solder, 260 °C, 30 seconds immersion time	No visible damage
- Resistance to Soldering Heat	MIL-STD-202G-method 210F IEC 60068-2-58	Condition B, no pre-heat of samples. Leadfree solder, 270 °C, 10 seconds immersion time Procedure 2 for SMD: devices fluxed and cleaned with isopropanol	±(0.5%+0.05Ω) No visible damage

REVISION HISTORY

REVISION	DATE	CHANGE NOTIFICATION	DESCRIPTION
Version 3	Jul 11, 2008	-	<ul style="list-style-type: none"> - Change to dual brand datasheet that describe RT0402 to RT2512 with RoHS compliant - Description of "Halogen Free Epoxy" added - Define global part number - Modify electrical characteristic.
Version 2	Dec 26, 2005	-	<ul style="list-style-type: none"> - New datasheet for thin film high precision - high stability chip resistors sizes of 0201/0402/0603/0805/1206/1210/2010/2512, 1%, 0.5%, 0.25%, 0.1%, 0.05%, TC25/50 with lead-free terminations - Replace the 0402 to 1210 parts of pdf files: TFX10_1_1, TFX11_5_2, TFX12_25_2, TFX13_1_3, TFX14_05_1, TFX20_1_2, TFX21_5_2, TFX22_25_2, TFX23_1_2, TFX24_05_1, and combine into a document. - Test method and procedure updated - PE tape added (paper tape will be replaced by PE tape)

“ Yageo reserves all the rights for revising the content of this datasheet without further notification, as long as the products itself are unchanged. Any product change will be announced by PCN.”