



SURFACE MOUNT LED LAMP FLASH LED

FOLF516CIWTR

White

PACKAGE DIMENSIONS

Top View:

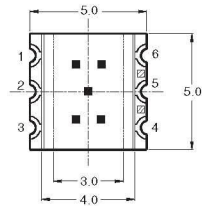

Side View:



Bottom View:

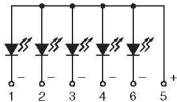
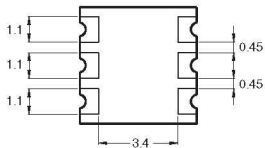

NOTE:

Dimensions for all drawings are in mm.
Tolerance = ± 0.1 mm unless specified.

Applications

- Auxiliary lighting for camera
- Flash lighting for camera with CMOS sensor

Description

This compact six-pin surface mount LED emits white light. Its multi-dice configuration offers high light output, making this LED an ideal choice for auxiliary lighting or flashing lighting in camera phones with CMOS sensor. This device utilizes InGaN/sapphire technology.

Features

- InGaN/Sapphire technology
- Footprint – 5.0(L) X 5.0(W) X 0.85(H) mm
- Typical viewing angle of 120°
- Available in 0.315" (8mm) width tape on 7" (178mm) diameter reel; 800 units per reel



SURFACE MOUNT LED LAMP FLASH LED

FOLF516CIWTR

White

ABSOLUTE MAXIMUM RATINGS ($T_A = 25^\circ\text{C}$ Unless otherwise specified)

Parameter	Symbol	Rating	Unit
Operating Temperature	T_{OPR}	-40 to +85	$^\circ\text{C}$
Storage Temperature	T_{STG}	-40 to +100	$^\circ\text{C}$
Lead Soldering Time	T_{SOL}	260 for 5 sec	$^\circ\text{C}$
Continuous Forward Current	I_F	150	mA
Peak Forward Current (Duty Factor = 10%, $t_p = 0.1$ ms)	I_{FM}	250	mA
Reverse Voltage ($I_R = 100 \mu\text{A}$)	V_R	5	V
Power Dissipation	P_D	600	mW

ELECTRICAL / OPTICAL CHARACTERISTICS ($T_A = 25^\circ\text{C}$)

Part Number	Min.	Typ.	Max.	Condition
Luminous Intensity (mcd)	2000	2400	2800	$I_F = 100\text{mA}$
Forward Voltage (V)	2.7	3.3	3.7	$I_F = 100\text{mA}$
Chromaticity coordinate	See page 3			$I_F = 100\text{mA}$
Reverse Current (μA)	-	-	250	$V_R = 10\text{V}$
Typical Viewing Angle ($^\circ$)	-	120	-	$I_F = 100\text{mA}$

Luminous intensity tolerance = $\pm 10\%$

Forward voltage tolerance = $\pm 0.1\text{V}$



SURFACE MOUNT LED LAMP FLASH LED

FOLF516CIWTR

White

Color Ranks

($I_F = 20\text{mA}$, $T_a = 25^\circ\text{C}$)

	Bin a0			
x	0.280	0.264	0.283	0.296
y	0.248	0.267	0.305	0.276

	Bin b5			
x	0.296	0.311	0.307	0.287
y	0.276	0.294	0.315	0.295

	Bin b3			
x	0.307	0.287	0.304	0.283
y	0.315	0.295	0.330	0.305

	Bin b6			
x	0.311	0.307	0.330	0.330
y	0.294	0.315	0.318	0.339

	Bin b4			
x	0.307	0.330	0.330	0.304
y	0.315	0.339	0.360	0.330

	Bin c0			
x	0.330	0.330	0.361	0.356
y	0.318	0.360	0.385	0.351

Chromaticity Diagram

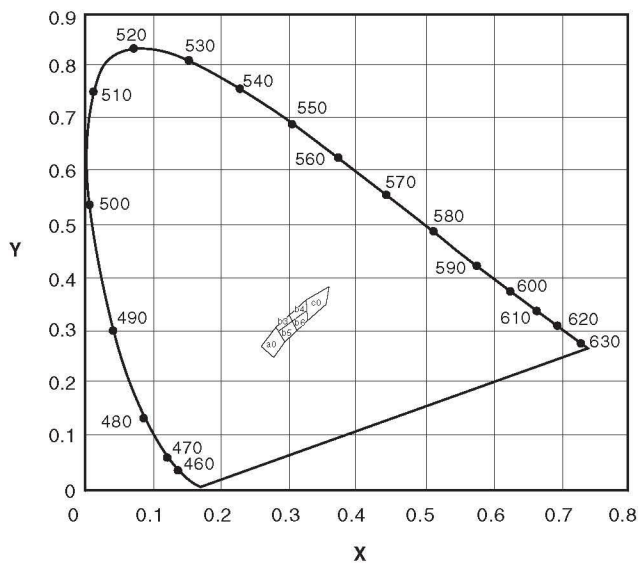



SURFACE MOUNT LED LAMP FLASH LED

FOLF516CIWTR

White

TYPICAL PERFORMANCE CURVES

Fig. 1 Forward Current vs. Forward Voltage

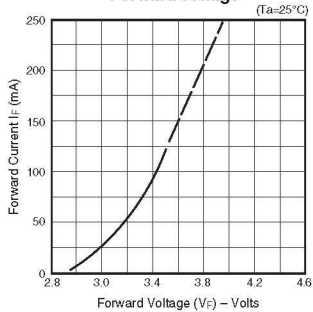

Fig. 2 Luminous Intensity vs. Forward Current

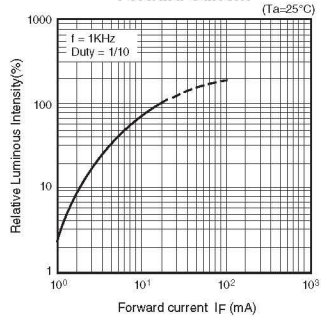

Fig. 3 Forward Current Derating Curve

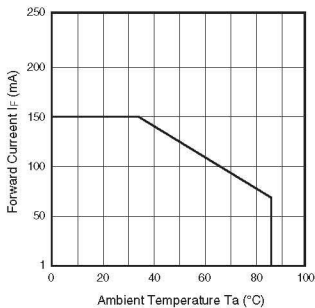

Fig. 4 Spectrum Distribution

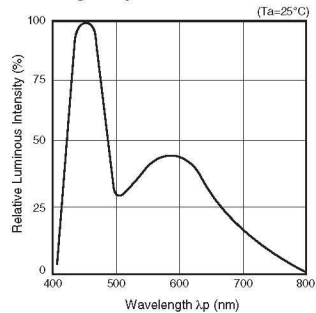
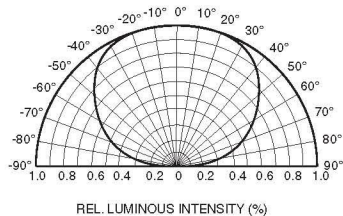

Fig. 5 Radiation Diagram





SURFACE MOUNT LED LAMP FLASH LED

FOLF516CIWTR

White

TYPICAL PERFORMANCE CURVES

Fig. 6 Luminance Incidence

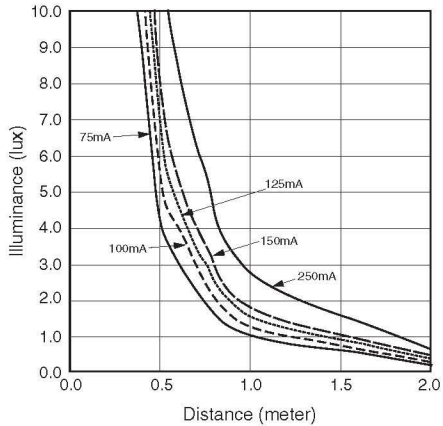
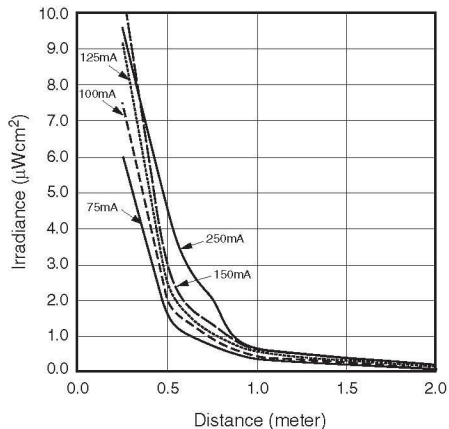

Fig. 7 Radiant Flux Density





SURFACE MOUNT LED LAMP FLASH LED

FOLF516CIWTR

White

TYPICAL PERFORMANCE CURVES

**Fig. 8 Colorimetry –
u'v' Chromaticity space**

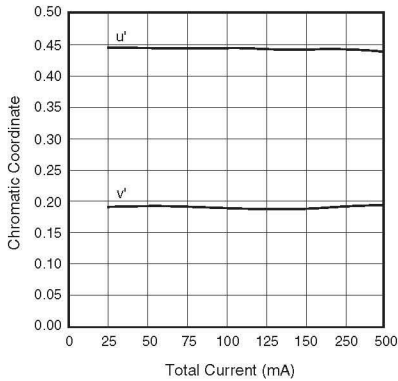

**Fig. 9 Colorimetry –
X, Y, Z Tristimulus System**

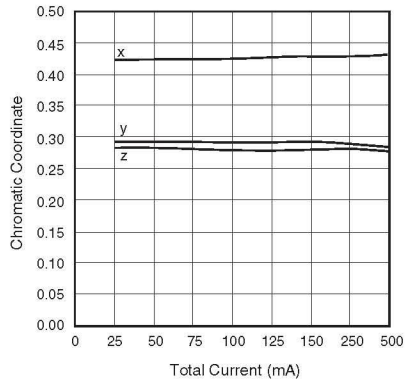
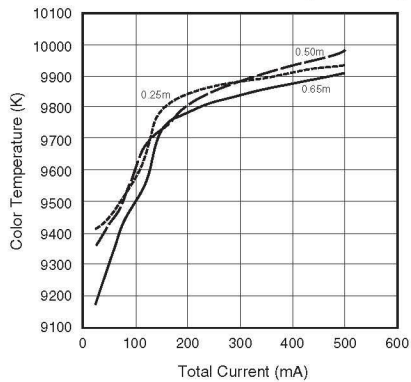

Fig. 10 Correlated Color Temperature (CCT)





SURFACE MOUNT LED LAMP FLASH LED

FOLF516CIWTR

White

RECOMMENDED PRINTED CIRCUIT BOARD PATTERN

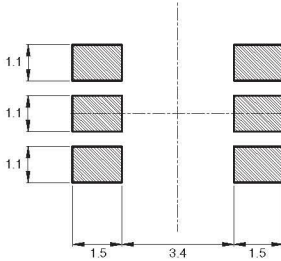

RECOMMENDED IR REFLOW SOLDERING PROFILE

Soldering Heat

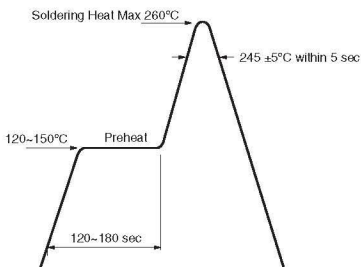

Reflow Solder Test

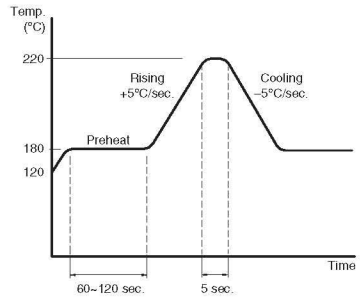



SURFACE MOUNT LED LAMP FLASH LED

FOLF516CIWTR

White

TAPE AND REEL DIMENSIONS

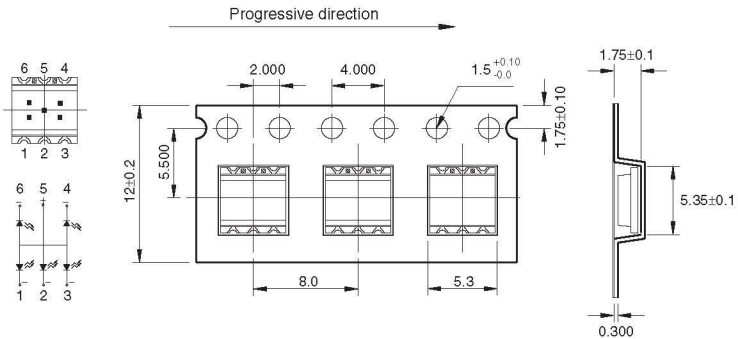
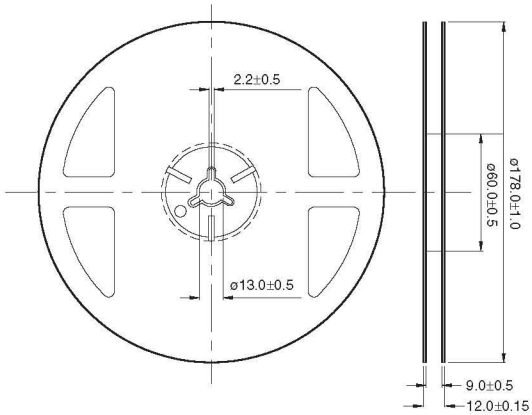

Dimensional tolerance is ± 0.1 mm unless otherwise specified

Angle: ± 0.5

Unit: mm



SURFACE MOUNT LED LAMP FLASH LED

FOLF516CIWTR**White**

DISCLAIMER

FAIRCHILD SEMICONDUCTOR RESERVES THE RIGHT TO MAKE CHANGES WITHOUT FURTHER NOTICE TO ANY PRODUCTS HEREIN TO IMPROVE RELIABILITY, FUNCTION OR DESIGN. FAIRCHILD DOES NOT ASSUME ANY LIABILITY ARISING OUT OF THE APPLICATION OR USE OF ANY PRODUCT OR CIRCUIT DESCRIBED HEREIN; NEITHER DOES IT CONVEY ANY LICENSE UNDER ITS PATENT RIGHTS, NOR THE RIGHTS OF OTHERS.

LIFE SUPPORT POLICY

FAIRCHILD'S PRODUCTS ARE NOT AUTHORIZED FOR USE AS CRITICAL COMPONENTS IN LIFE SUPPORT DEVICES OR SYSTEMS WITHOUT THE EXPRESS WRITTEN APPROVAL OF THE PRESIDENT OF FAIRCHILD SEMICONDUCTOR CORPORATION. As used herein:

1. Life support devices or systems are devices or systems which, (a) are intended for surgical implant into the body, or (b) support or sustain life, and (c) whose failure to perform when properly used in accordance with instructions for use provided in the labeling, can be reasonably expected to result in a significant injury of the user.
2. A critical component in any component of a life support device or system whose failure to perform can be reasonably expected to cause the failure of the life support device or system, or to affect its safety or effectiveness.