

ROYAL OHM

Metal Oxide Film Fixed Resistors

Features:

- Excellent flame retardant coating
- Stable performance in diverse environments
- High purity ceramic core
- Meet EIAJ-RC2655A requirements
- High safety standard
- Too low or too high ohmic value can be supplied only case by case

General Specification & Dimensions

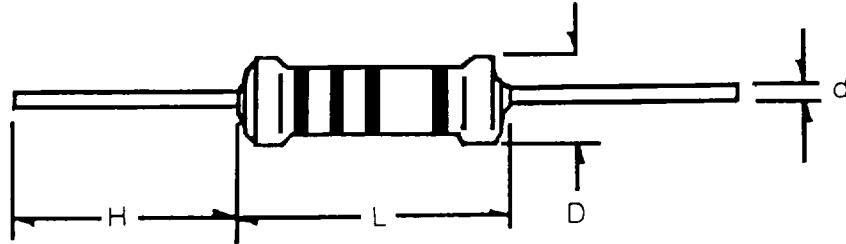

Style	Normal Size				Small Size				Max. Working V	Max. Overload V	Dielectric Withstanding V	Resistance Range
	L Max.	D Max.	H±3	d $\begin{smallmatrix} +0.02 \\ -0.05 \end{smallmatrix}$	L Max.	D Max.	H±3	d $\begin{smallmatrix} +0.02 \\ -0.05 \end{smallmatrix}$				
MOR-1/2W	10	4	28	0.6	7.5	2.5	28	0.6	250	400	250	0.3Ω~ 50KΩ
MOR-1W	12	5	28	0.7	10	4	28	0.7	350	600	350	0.3Ω~ 50KΩ
MOR-2W	16	5.5	28	0.8	12	5	28	0.7	350	600	350	0.3Ω~ 50KΩ
MOR-3W	17.5	6.5	28	0.8	16	5.5	28	0.8	N:500 S:350	N:800 S:600	500	5Ω~100KΩ
MOR-5W	26	8.5	38	0.8	25	8	38	0.8	N:750 S:500	N:1000 S:800	500	5Ω~150KΩ
MOR-7W	32	8.5	38	0.8					750	1000	750	20Ω~150KΩ
MOR-8W	41	8.5	38	0.8					750	1000	750	30Ω~200KΩ
MOR-9W	54	8.5	38	0.8					750	1000	750	50Ω~200KΩ

N: NORMAL S: SMALL * 5W-SS (Super Small) (D6.5 × L17.5) can be supplied H: 28

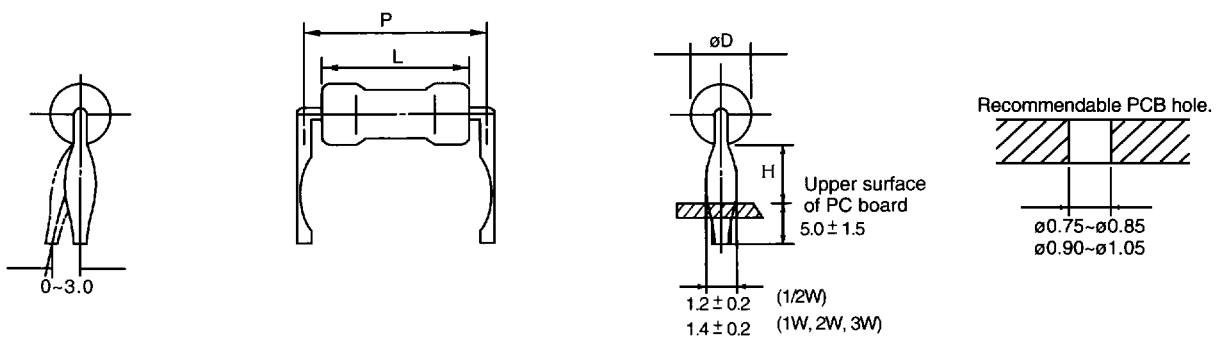

Formed Type

Power Rating (W) At 70°C	Normal Size					Small Size				
	L Max.	D Max.	H±2	P	d $\begin{smallmatrix} +0.02 \\ -0.05 \end{smallmatrix}$	L Max.	D Max.	H±2	P	d $\begin{smallmatrix} +0.02 \\ -0.05 \end{smallmatrix}$
1/2W	10	4	7	12.5 ± 1.5	0.6					
1W	12	5	7	15 ± 1.5	0.7	10	4	7	12.5 ± 1.5	0.7
2W	16	5.5	10	20 ± 2	0.8	12	5	7	15 ± 1.5	0.7
3W	17.5	6.5	12	25 ± 2	0.8	16	5.5	10	20 ± 2	0.8
5W	26	8.5	12	31 ± 2	0.8	25	8	12	31 ± 2	0.8

ROYAL OHM

Metal Oxide Film Fixed Resistors

Performance Specifications

Characteristics	Limits	Test Methods															
Temperature coefficient JIS-C-5202 5.2	± 350PPM	Natural resistance change per temp. degree centigrade. $\frac{R_2 - R_1}{R_1(t_2 - t_1)} \times 10^6 \text{ (ppm/}^\circ\text{C)}$ R ₁ : Resistance value at room temperature (t ₁) R ₂ : Resistance value at room temp. plus 100°C (t ₂) Test Pattern: Room temp., Room temp. + 100°C															
Dielectric withstanding voltage JIS-C-5202 5.7	No evidence of flashover, mechanical damage, arcing or insulation break down.	Resistors shall be clamped in the trough of a 90° metallic V-block and shall be tested at AC potential respectively specified in the above list for 60 +10/-0 seconds.															
Temperature cycling JIS-C-5202 7.4	Resistance change rate is ± (2% + 0.05Ω) Max. with no evidence of mechanical damage	Resistance change after continuous five cycles for duty cycle specified below. <table border="1" style="width: 100%; border-collapse: collapse;"> <thead> <tr> <th>Step</th> <th>Temperature</th> <th>Time</th> </tr> </thead> <tbody> <tr> <td>1</td> <td>-55°C ± 3°C</td> <td>30 minutes</td> </tr> <tr> <td>2</td> <td>Room temp.</td> <td>10~15 minutes</td> </tr> <tr> <td>3</td> <td>+155°C ± 2°C</td> <td>30 minutes</td> </tr> <tr> <td>4</td> <td>Room temp.</td> <td>10~15 minutes</td> </tr> </tbody> </table>	Step	Temperature	Time	1	-55°C ± 3°C	30 minutes	2	Room temp.	10~15 minutes	3	+155°C ± 2°C	30 minutes	4	Room temp.	10~15 minutes
Step	Temperature	Time															
1	-55°C ± 3°C	30 minutes															
2	Room temp.	10~15 minutes															
3	+155°C ± 2°C	30 minutes															
4	Room temp.	10~15 minutes															
Humidity (Steady state) JIS-C-5202 7.5	Resistance change rate is ± (2% + 0.05Ω) Max. with no evidence of mechanical damage	Temporary resistance change after a 240 hours exposure in a humidity test chamber controlled at 40°C ± 2°C and 90 to 95% relative humidity.															
Short-time overload JIS-C-5202 5.5	Resistance change rate is N: ± (1% + 0.05) Max. S: ± (5% + 0.05) Max. with no evidence of mechanical damage.	Permanent resistance change after the application of a potential of 2.5 times RCWV or the max. overload voltage respectively specified in the above list, whichever less for 5 seconds.															
Pulse overload JIS-C-5202 5.8	Resistance change rate is N: ± (2% + 0.05) Max. S: ± (5% + 0.05) Max. with no evidence of mechanical damage.	Resistance change after 10,000 cycles (1 second "ON", 25 seconds "OFF") at 4 times RCWV or the max. pulse overload voltage.															
Load life in humidity JIS-C-5202 7.9	Resistance change rate is ± (5% + 0.05Ω) Max. with no evidence of mechanical damage	Resistance change after 1,000 hours (1.5 hours "on", 0.5 hour "off") at RCWV in a humidity chamber controlled at 40°C ± 2°C and 90 to 95% relative humidity.															
Load life JIS-C-5202 7.10	Resistance change rate is ± (5% + 0.05Ω) Max. with no evidence of mechanical damage	Permanent resistance change after 1,000 hours operating at RCWV, with duty cycle of 1.5 hours "on", 0.5 hour "off" at 70°C ± 2°C ambient.															
Terminal strength JIS-C-5202 6.1	With no evidence of mechanical damage	Direct load: Resistance to a 2.5kg direct load for 10 seconds in the direction of the longitudinal axis of the terminal leads. Twist test: Terminal leads shall be bent through 90° at a point of about 6mm from the body of the resistor and shall be rotated through 360° about the original axis of the bent terminal in alternating direction for a total of 3 rotations.															
Resistance to soldering heat JIS-C-5202 6.4	Resistance change rate is ± (1% + 0.05Ω) Max. with no evidence of mechanical damage	Permanent resistance change when leads immersed to 3.2 to 4.8mm from the body in 350°C ± 10°C solder for 3 ± 0.5 seconds.															
Solderability JIS-C-5202 6.5	95% coverage Min.	The area covered with a new, smooth, clean, shiny and continuous surface free from concentrated pinholes. Test temp. of solder: 235°C ± 5°C Dwell time in solder: 3 + 0.5/-0 seconds															
Resistance to solvent JIS-C-5202 6.9	No deterioration of protective coatings and markings	Specimens shall be immersed in a bath of trichroethane completely for 3 minutes with ultrasonic.															
Flame retardant JIS-C-5202 7.12	No evidence of flaming or arcing	Resistors shall resist flaming or arcing when overloaded up to 16 times RCWV.															