

1 - of - 8 Decoder/ Demultiplexer

This high-speed 1-of-8 decoder/demultiplexer is ideally suited for high-speed bipolar memory chip select address decoding. The multiple input enables allow parallel expansion to a 1-of-24 decoder using just three 'AC138/ACT138 devices or a 1-of-3 decoder using four 'AC138/ACT138 devices and one inverter.

- Advanced very high speed CMOS
- Outputs source/sink 24 mA
- Transmission line driving 50 ohms
- ACT has TTL compatible inputs
- Operation from 2 to 6 volts guaranteed
- DC & AC Parameters guaranteed over -40 to +85°C

DV74AC138
DV74ACT138

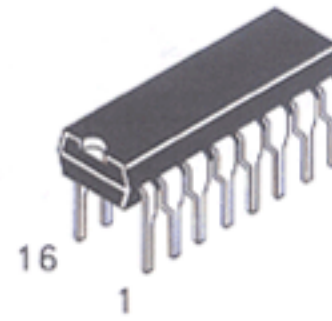

N Suffix
Plastic DIP
AVG-001 Case

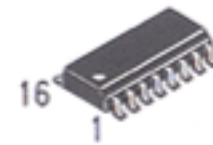

D Suffix
Plastic SOP
AVG-002 Case

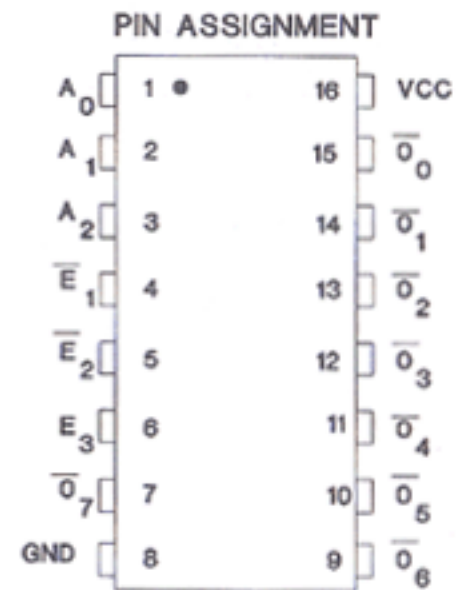
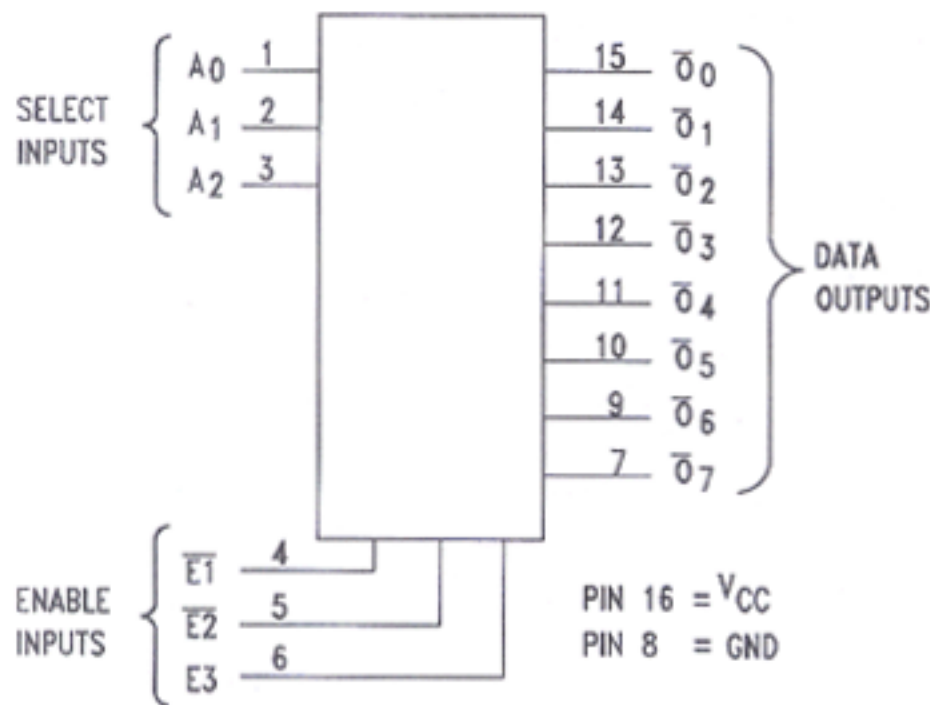

TRUTH TABLE

Inputs						Output							
\bar{E}_1	\bar{E}_2	E_3	A_0	A_1	A_2	\bar{O}_0	\bar{O}_1	\bar{O}_2	\bar{O}_3	\bar{O}_4	O_5	\bar{O}_6	\bar{O}_7
H	X	X	X	X	X	H	H	H	H	H	H	H	H
X	H	X	X	X	X	H	H	H	H	H	H	H	H
X	X	L	X	X	X	H	H	H	H	H	H	H	H
L	L	H	L	L	L	L	H	H	H	H	H	H	H
L	L	H	H	L	L	H	L	H	H	H	H	H	H
L	L	H	L	H	L	H	H	L	H	H	H	H	H
L	L	H	H	H	L	H	H	H	L	H	H	H	H
L	L	H	L	H	H	H	H	H	H	L	H	H	H
L	L	H	H	H	H	H	H	H	H	H	L	H	H
L	L	H	H	H	H	H	H	H	H	H	H	L	L

H=High Logic Level

L=Low Logic Level

X=Don't Care

ABSOLUTE MAXIMUM RATINGS

Maximum ratings are those values beyond which damage to the device may occur.

Symbol	Parameter	AC138, ACT138	Unit
V _{CC}	DC Supply Voltage (Referenced to GND)	- 0.5 to +7.0	V
V _{IN}	DC Input Voltage (Referenced to GND)	- 0.5 to V _{CC} +0.5	V
V _{OUT}	DC Output Voltage (Referenced to GND)	- 0.5 to V _{CC} +0.5	V
I _{IN}	DC Input Current, per Pin	± 20	mA
I _{OUT}	DC Output Sink/Source Current, per Pin	± 50	mA
I _{CC}	DC V _{CC} or GND Current per Output Pin	± 50	mA
T _{STG}	Storage Temperature	- 65 to +150	°C

GUARANTEED OPERATING CONDITIONS

Symbol	Parameter	Min	Typ	Max	Unit	
V _{CC}	Supply Voltage	'AC	2.0	5.0	6.0	V
		'ACT	4.5	5.0	5.5	
V _{IN} , V _{OUT}	DC Input Voltage, Output Voltage, (Ref. to GND)	0		V _{CC}	V	
t _r , t _f	Input Rise and Fall Time (Note 1) 'AC Devices	V _{CC} @ 3.0 V			150	ns/V
		V _{CC} @ 4.5 V			40	ns/V
		V _{CC} @ 5.5 V			25	ns/V
t _r , t _f	Input Rise and Fall Time (Note 2) 'ACT Devices	V _{CC} @ 4.5 V			10	ns/V
		V _{CC} @ 5.5 V			8.0	ns/V
T _A	Operating Ambient Temperature Range	-40		85	°C	
C _{PD}	Power Dissipation Capacitance	V _{CC} = 5.0 V		60	pF	
C _{IN}	Input Capacitance	V _{CC} = 5.0 V		4.5	pF	

1. V_{IN} from 30% to 70% V_{CC}

2. V_{IN} from 0.8 to 2.0 V

AC — 138

DC ELECTRICAL CHARACTERISTICS

Symbol	Parameter	Conditions	V _{CC} (V)	74AC138			Unit		
				T _A = +25°C		T _A = -40 to +85°C			
				Typ	Guaranteed Limits				
V _{IH}	Minimum High Level Input Voltage	V _{OUT} = 0.1V or V _{CC} - 0.1 V	3.0	1.5	2.1	2.1	V		
			4.5	2.25	3.15	3.15			
			5.5	2.75	3.85	3.85			
V _{IL}	Maximum Low Level Input Voltage	V _{OUT} = 0.1V or V _{CC} - 0.1 V	3.0	1.5	0.9	0.9	V		
			4.5	2.25	1.35	1.35			
			5.5	2.75	1.65	1.65			
V _{OH}	Minimum High Level Output Voltage	I _{OUT} = -50 μA	3.0	2.99	2.9	2.9	V		
			4.5	4.49	4.4	4.4			
			5.5	5.49	5.4	5.4			
		V _{IN} = V _{IL} or V _{IH}	I _{OH}	-12mA	3.0		2.56	2.46	V
				-24mA	4.5		3.86	3.76	
				-24 mA	5.5		4.86	4.76	
V _{OL}	Maximum Low Level Output Voltage	I _{OUT} = 50 μA	3.0	0.002	0.1	0.1	V		
			4.5	0.001	0.1	0.1			
			5.5	0.001	0.1	0.1			
		V _{IN} = V _{IL} or V _{IH}	I _{OL}	12mA	3.0		0.36	0.44	V
				24mA	4.5		0.36	0.44	
				24 mA	5.5		0.36	0.44	

Symbol	Parameter	Conditions	V _{CC} (V)	74AC138			Unit
				T _A = +25°C		T _A = -40 to +85°C	
				Typ	Guaranteed Limits		
I _{IN}	Maximum Input Leakage Current	V _{IN} =V _{CC} , GND	5.5		±0.1	±1.0	μA
I _{CC}	Maximum Quiescent Supply Current	V _{IN} = V _{CC} or GND	5.5		8.0	80	μA

AC CHARACTERISTICS over full operating conditions

Symbol	Parameter	V _{CC} ±10% (V)	AC138				Unit
			T _A = +25°C C _L = 50 pF		T _A = -40°C to +85°C C _L = 50 pF		
			Min	Max	Min	Max	
t _{PLH}	Propagation Delay A _n to \bar{O}_n	3.3	1.5	13.0	1.5	15.0	ns
		5.0	1.5	9.5	1.5	10.5	
t _{PHL}	Propagation Delay A _n to \bar{O}_n	3.3	1.5	12.5	1.5	14.0	ns
		5.0	1.5	9.0	1.5	10.5	
t _{PLH}	Propagation Delay \bar{E}_1 or \bar{E}_2 to \bar{O}_n	3.3	1.5	15.0	1.5	16.0	ns
		5.0	1.5	11.0	1.5	12.0	
t _{PHL}	Propagation Delay \bar{E}_1 or \bar{E}_2 to \bar{O}_n	3.3	1.5	13.5	1.5	15.0	ns
		5.0	1.5	9.5	1.5	10.5	
t _{PLH}	Propagation Delay E ₃ to \bar{O}_n	3.3	1.5	15.5	1.5	16.5	ns
		5.0	1.5	11.0	1.5	12.5	
t _{PHL}	Propagation Delay E ₃ to \bar{O}_n	3.3	1.5	13.0	1.5	14.0	ns
		5.0	1.5	8.0	1.0	9.5	

ACT — 138

DC ELECTRICAL CHARACTERISTICS

Symbol	Parameter	Conditions	V _{CC} (V)	ACT138			Unit
				T _A = +25°C		T _A = -40 to +85°C	
				Typ	Guaranteed Limits		
V _{IH}	Minimum High Level Input Voltage	V _{OUT} = 0.1V or V _{CC} - 0.1 V	4.5	1.5	2.0	2.0	V
			5.5	1.5	2.0	2.0	
V _{IL}	Maximum Low Level Input Voltage	V _{OUT} = 0.1V or V _{CC} - 0.1 V	4.5	1.5	0.8	0.8	V
			5.5	1.5	0.8	0.8	
V _{OH}	Minimum High Level Output Voltage	I _{OUT} = -50 μA	4.5	4.49	4.4	4.4	V
			5.5	5.49	5.4	5.4	
		V _{IN} = V _{IL} or V _{IH} I _{OH} -24mA -24 mA	4.5		3.86	3.76	V
			5.5		4.86	4.76	
V _{OL}	Maximum Low Level Output Voltage	I _{OUT} = 50 μA	3.0	0.001	0.1	0.1	V
			4.5	0.001	0.1	0.1	
		V _{IN} = V _{IL} or V _{IH} I _{OL} 24mA 24 mA	3.0				V
			4.5		0.36	0.44	
5.5		0.36	0.44				
I _{IN}	Maximum Input Leakage Current	V _I =V _{CC} , GND	5.5		±0.1	±1.0	μA
ΔI _{CCCT}	Additional Max I _{CC} /Input	V _I =V _{CC} - 2.1 V	5.5	0.6		1.5	mA
I _{CC}	Maximum Quiescent Supply Current	V _{IN} = V _{CC} or GND	5.5		8.0	80	μA

AC CHARACTERISTICS over full operating conditions

Symbol	Parameter	V _{CC} ±10% (V)	ACT138				Unit
			T _A = +25°C C _L = 50 pF		T _A = -40°C to +85°C C _L = 50 pF		
			Min	Max	Min	Max	
t _{PLH}	Propagation Delay, A _n to \bar{O}_n	5.0	1.5	10.5	1.5	11.5	ns
t _{PHL}	Propagation Delay, A _n to \bar{O}_n	5.0	1.5	10.5	1.5	11.5	ns
t _{PLH}	Propagation Delay, $\bar{E}1$ or $\bar{E}2$ to \bar{O}_n	5.0	2.5	11.5	2.0	12.5	ns
t _{PHL}	Propagation Delay, $\bar{E}1$ or $\bar{E}2$ to \bar{O}_n	5.0	2.0	11.5	2.0	12.5	ns
t _{PLH}	Propagation Delay, E ₃ to \bar{O}_n	5.0	2.5	12.0	2.0	13.0	ns
t _{PHL}	Propagation Delay, E ₃ to \bar{O}_n	5.0	2.0	10.5	1.5	11.5	ns

SWITCHING WAVEFORMS

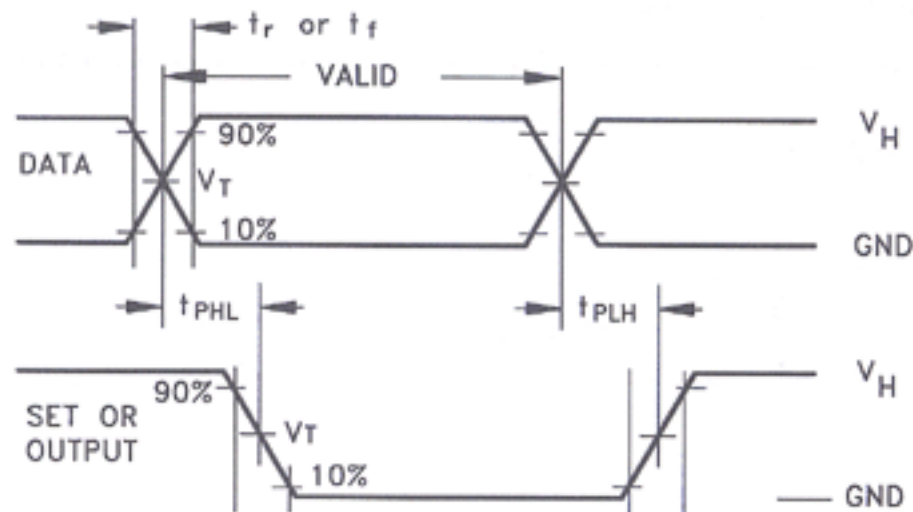

Input and output threshold voltage:
 $V_T = 50\% V_{CC}$ for AC; 1.5V for ACT
 $V_H = V_{CC}$ for AC, 3V for ACT