

IWS SERIES - 10 WATT

DESCRIPTION

IWS DC/DC converters offer excellent regulation and isolation in an industry-standard package. Available in several input versions, the IWS is perfect for industrial, datacom, or telecom applications. The IWS features short circuit protection and 500 VDC isolation. Please see the IWD series for dual-output applications.



FEATURES

- Industry-Standard Package
- Industry-Standard Pinout
- 85°C Case Operation
- Short-Circuit Protection
- 5, 12, 24, and 48V Input Versions
- Input Pi Filter and 6-Sided Shielding
- Regulated Outputs
- 500V Isolation

TECHNICAL SPECIFICATIONS

Input	
Voltage Range	
5 VDC Nominal	4.5 - 9 VDC
12 VDC Nominal	9 - 18 VDC
24 VDC Nominal	18 - 36 VDC
48 VDC Nominal	36 - 72 VDC
Reflected Ripple	20% I_{in} Max.
Reverse Input Current	100% I_{in} Max.

Output	
Setpoint accuracy	±1%
Line regulation V_{in} Min. - V_{in} Max., I_{out} Rated	±0.5% V_{out}
Load regulation I_{out} Min. - I_{out} Max., V_{in} Nom.	±1.0% V_{out}
Minimum output current	10 % I_{out} Rated
Dynamic regulation, loadstep	25% I_{out}
Pk deviation	1% V_{out}
Settling time	500 ms
Temperature coefficient	0.02%/°C
Ripple and noise, 20 MHz BW	1% V_{out} Nom.
Short-circuit protection 1	Continuous
Current Limit	130%

Notes
¹ Continuous short-circuit protection is provided. Long-term continuous operation in this mode is not recommended. Converter will auto-restart once fault has been removed.
Specifications typically at 25°C, normal line, and full load, unless otherwise stated.
Soldering Conditions: I/O pins, 260°C, ten seconds; fully compatible with commercial wave-soldering equipment.
Safety: Agency approvals may vary from model to model. Please consult factory for specific model information.

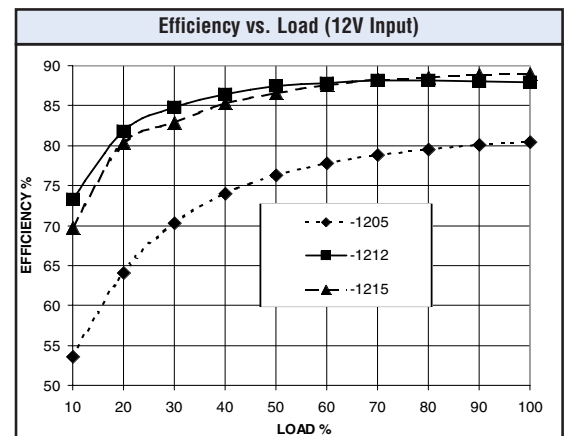
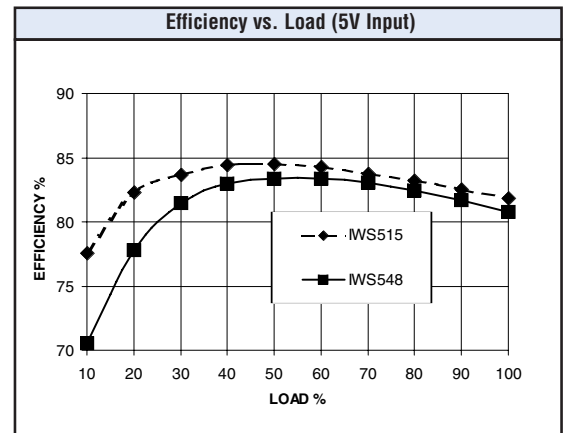

General	
Switching Frequency	300 kHz
Isolation	
Input - Output	500 VDC
Input - Case	500 VDC
Output - Case	500 VDC
Isolation Resistance - Input to Output	10 ⁹ Ohms
Standard Case Operating Range	-25 to +85°C
Industrial Range (add -I to p/n)	-40 to +85°C
Storage Range	-40 to +125°C
Humidity Max., Non-Condensing	95%
Vibration, 3 Axes, 5 Min Each	5 g, 10 - 55 Hz
Safety	UL, cUL, TUV
Weight (approx.)	1.4 oz

IWS SERIES - 10 WATT

MODELS - (See the last page of Section for options.)

MODEL	INPUT VOLTAGE (VOLTS)	INPUT VOLTAGE RANGE (VOLTS)	MAXIMUM INPUT CURRENT (AMPS)*	OUTPUT VOLTAGE (VOLTS)	RATED OUTPUT CURRENT (AMPS)	RIPPLE & NOISE pk-pk (mV)	TYPICAL EFFICIENCY**
IWS505	5	4.5 - 9	3.20	5	2.00	100	78%
IWS512	5	4.5 - 9	3.70	12	1.00	120	80%
IWS515	5	4.5 - 9	3.45	15	0.75	150	82%
IWS524	5	4.5 - 9	3.60	24	0.50	240	83%
IWS548	5	4.5 - 9	3.55	48	0.25	480	84%
IWS1212	12	9 - 18	1.80	12	1.00	120	82%
IWS1215	12	9 - 18	1.65	15	0.75	150	84%
IWS1224	12	9 - 18	1.75	24	0.50	240	85%
IWS1248	12	9 - 18	1.75	48	0.25	480	86%
IWS2424	24	18 - 36	0.95	24	0.50	240	85%
IWS2448	24	18 - 36	0.90	48	0.25	480	86%
IWS4824	48	36 - 72	0.45	24	0.50	240	85%
IWS4848	48	36 - 72	0.45	48	0.25	480	89%

NOTES: * Maximum input current at minimum input voltage, maximum rated output power.

** At nominal V_{in} , rated output.

MECHANICAL DRAWING

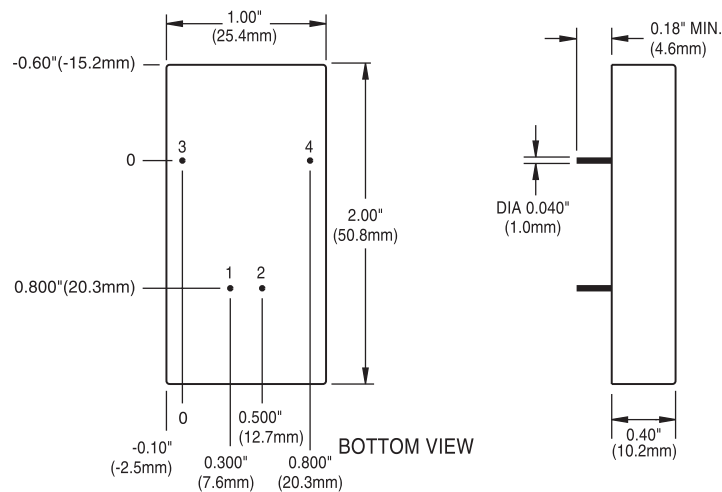

Thermal Impedance	
Natural Convection	15.4 °C/W
100 LFM	12.2 °C/W
200 LFM	9.3 °C/W
300 LFM	7.4 °C/W
400 LFM	6.4 °C/W

Note:
Thermal impedance data is dependent on many environmental factors. The exact thermal performance should be validated for specific application.

Pin	Function
1	+ V_{in}
2	- V_{in}
3	+ V_{out}
4	- V_{out}

Tolerances	
Inches:	(Millimeters)
.XX ± 0.040	.X ± 1.0
.XXX ± 0.010	.XX ± 0.25
Pin:	
± 0.002	± 0.05
Case:	
+0.04, -0.00	+1.0, -0.0
(Dimensions as listed unless otherwise specified.)	

OPTIONS

When ordering equipment options, use the following suffix information. Select the option(s) that you prefer and add them to the model number. Example ordering options are located below the options table.

OPTION	SUFFIX	APPLICABLE SERIES	REMARKS
Negative Logic	N	HAS, HBD, HBS, HES, HLS, HLD, LES, QBS, QES, QLS, TES, TQD	TTL "Low" Turns Module ON TTL "High" Turns Module OFF
Lucent-Compatible Trim	T	HAS, HBD, HBS, HES, HLS, QBS, QES, QLS	
Terminal Strip	TS	XWS, XWD, XWT	
Trim	1	IAS, LES	
Enable	2	IAD, IAS, LES, SMS	
Trim and Enable	3	IAS, LES	
Pin Length and Heatsink Options			Standard Pin Length is 0.180" (4.6mm)
0.110" (2.8mm) Pin Length	8	All Leaded Models	
0.150" (3.8mm) Pin Length	9	All Leaded Models	
0.24" (6.1mm) Horizontal Heatsink	1H	All 1/4-Bricks, 1/2-Bricks, 3/4-Bricks, Full-Bricks (Except HLS, HLD, QLS, TLD, and TKD Packages)	Includes Thermal Pad
0.24" (6.1mm) Vertical Heatsink	1V	All 1/4-Bricks, 1/2-Bricks, 3/4-Bricks, Full-Bricks (Except HLS, HLD, QLS, TLD, and TKD Packages)	Includes Thermal Pad
0.45" (11.4mm) Horizontal Heatsink	2H	All 1/4-Bricks, 1/2-Bricks, 3/4-Bricks, Full-Bricks (Except HLS, HLD, QLS, TLD, and TKD Packages)	Includes Thermal Pad
0.45" (11.4mm) Vertical Heatsink	2V	All 1/4-Bricks, 1/2-Bricks, 3/4-Bricks, Full-Bricks (Except HLS, HLD, QLS, TLD, and TKD Packages)	Includes Thermal Pad
0.95" (24.1mm) Horizontal Heatsink	3H	All 1/4-Bricks, 1/2-Bricks, 3/4-Bricks, Full-Bricks (Except HLS, HLD, QLS, TLD, and TKD Packages)	Includes Thermal Pad
0.95" (24.1mm) Vertical Heatsink	3V	All 1/4-Bricks, 1/2-Bricks, 3/4-Bricks, Full-Bricks (Except HLS, HLD, QLS, TLD, and TKD Packages)	Includes Thermal Pad

Example Options:

HBS050ZG-ANT3V = HBS050ZG-A with negative logic, Lucent-compatible trim, and 0.95" vertical heatsink.

LES015YJ-3N = LES015YJ with optional trim and enable, negative logic.

QBS066ZG-AT8 = QBS066ZG-A with Lucent-compatible trim and 0.110" pin length.

NUCLEAR AND MEDICAL APPLICATIONS - Power-One products are not authorized for use as critical components in life support systems, equipment used in hazardous environments, or nuclear control systems without the express written consent of the respective divisional President of Power-One, Inc.

TECHNICAL REVISIONS - The appearance of products, including safety agency certifications pictured on labels, may change depending on the date manufactured. Specifications are subject to change without notice.

For the Most Up-To-Date Information

www.power-one.com

24 Hours/Day—7 Days/Week