

2.5mm Pitch Connector Directly Mounted on Board (Product Compliant to UL/CSA Standard)

DF2 Series

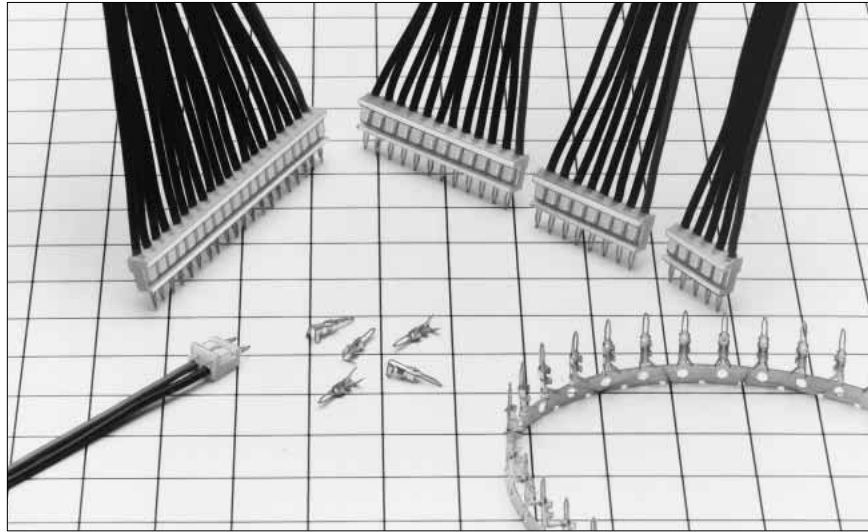

■ Features

1. Header Cost Saving

Based on the harnesses product at the both ends of insertion/extraction socket and directly mounted connector, the both socket harnesses can afford to save either of two necessary headers, while functions to separate mutual boards are remained.

2. Space Saving

This connector is designed in a narrow space.

Board mounting height : **5.5mm**

Width : **4.0mm**

3. Board Pre-fixed Mechanism

Since the connector is smoothly press-fitted to the board, it can be pre-fixed to the board.

■ Applications

Personal computers, facsimiles, printers and other business equipment.

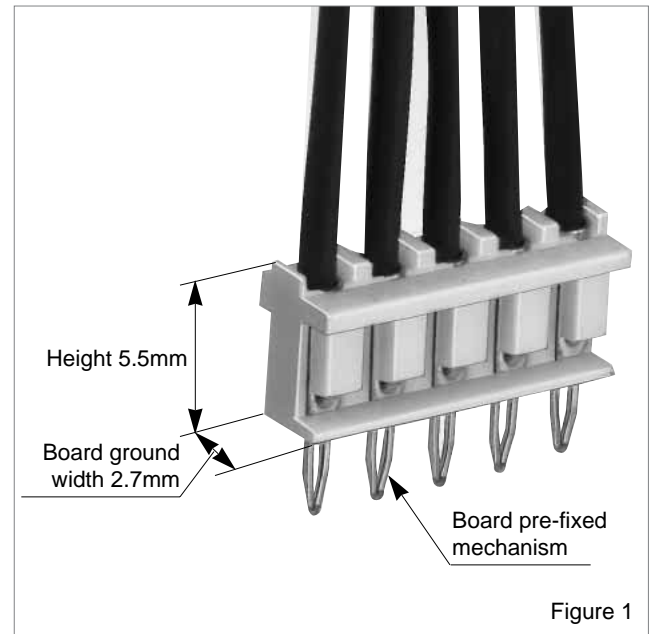

Figure 1

Product Specifications

Rating	Current rating (Note1)	Cable Size	AWG 24 : 3A AWG 26 : 2A AWG 28 : 1A	Operating Temperature Range	-35 to +85°C (Note2)
	Voltage rating		250V AC	Operating Moisture Range	40 to 80%
				Storage Temperature Range	-10 to +60°C (Note3)
				Storage Moisture Range	40 to 70% (Note3)

Standard Value Compliant to UL CSA Safety Standard		
Rating	Rated Current	Wire Size AWG 24 to 28 : 1A
	Rated Voltage	30V AC/CSA

■UL CSA Safety Standard File No.
 UL :E52653
 CSA :LR95109

Item	Specification	Condition
1. Insulation Resistance	1000M ohms min.	500V DC
2. Withstanding voltage	No flashover or insulation breakdown.	650V AC/1 minute
3. Resistance in Crimping Area	30m ohms Max	100mA
4. Vibration	No damage, cracks, or parts looseness.	Frequency: 10 to 55 Hz, single amplitude of 0.75 mm, 2 hours in each of the 3 directions.
5. Humidity (Steady state)	Contact resistance: 30m ohms max. Insulation resistance: 1000M ohms min.	96 hours at temperature of 40°C and humidity of 90% to 95%
6. Temperature Cycle	Contact resistance: 30m ohms max. Insulation resistance: 1000M ohms min.	(-55°C: 30 minutes → 5 to 35°C: 10 minutes 85°C: 30 minutes → 5 to 35°C: 10 minutes) 5 cycles
7. Resistance to Soldering heat	No deformation of components affecting performance.	Flow: 250°C for 10 seconds
		Manual soldering: 300°C for 3 seconds

Note 1: The rated current will be changed according to cable sizes for use.

Note 2: Includes temperature rise caused by current flow.

Note 3: The term "storage" refers to products stored for long period of time prior to mounting and use. Operating Temperature Range and Humidity range covers non conducting condition of installed connectors in storage, shipment or during transportation.

Note 4: Information contained in this catalog represents general requirements for this Series. Contact us for the drawings and specifications for a specific part number shown.

Material

Product	Part	Material	Finish	Remarks
Crimping Socket	Insulator	Polyamide	White	UL94V-0
Plug Crimping Contact	Contact	Brass	Tin plated	—

Ordering Information

●Crimping Plug

DF2 - * P - 2.5 C
 ① ② ③ ④ ⑤

① Series Name : DF 2	④ Contact Pitch : 2.5mm
② Number of Contacts : 2 to 16, 18, 20	⑤ C : Crimping Plug
③ Connector Type P : Plug	

●Contact

DF2 - 2428 - PCF
 ① ②

① Applicable Cable Size 2428: AWG 24 to 28	② Packaging Type PCF : Plug Contact, Reel PC : Plug Contact, Bag
---	--

DF2 Series 2.5mm Pitch Connector Directly Mounted on Board (Product Compliant to UL/CSA Standard)

■Crimping Plug

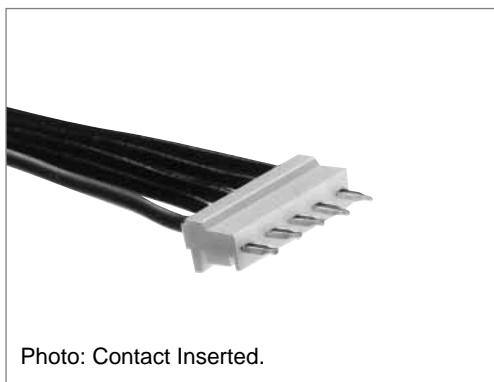

●Printed Board Through-hole Diameter : $\phi 0.8^{+0.1}$

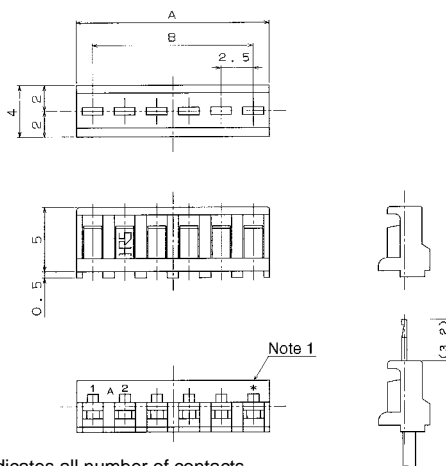

Note1: Contact No. indicates all number of contacts.

Note2: Do not clean the cable with heat nor trichloroethane. Contact insertion view

Unit: mm

Part Number	CL No.	Number of Contacts	A	B	RoHS	Part Number	CL No.	Number of Contacts	A	B	RoHS	
DF2- 2P-2.5C	542-0001-6	2	5	2.5	YES	DF2-11P-2.5C	542-0010-7	11	27.5	25	YES	
DF2- 3P-2.5C	542-0002-9	3	7.5	5		DF2-12P-2.5C	542-0011-0	12	30	27.5		
DF2- 4P-2.5C	542-0003-1	4	10	7.5		DF2-13P-2.5C	542-0012-2	13	32.5	30		
DF2- 5P-2.5C	542-0004-4	5	12.5	10		DF2-14P-2.5C	542-0013-5	14	35	32.5		
DF2- 6P-2.5C	542-0005-7	6	15	12.5		DF2-15P-2.5C	542-0014-8	15	37.5	35		
DF2- 7P-2.5C	542-0006-0	7	17.5	15		DF2-16P-2.5C	542-0015-0	16	40	37.5		
DF2- 8P-2.5C	542-0007-2	8	20	17.5		DF2-18P-2.5C	542-0017-6	18	45	42.5		
DF2- 9P-2.5C	542-0008-5	9	22.5	20.5		DF2-20P-2.5C	542-0019-1	20	50	47.5		
DF2-10P-2.5C	542-0009-8	10	25	22.5								

Note : Bag packaging(100 pieces/bag). Order by number of bags.

■Crimping Contact

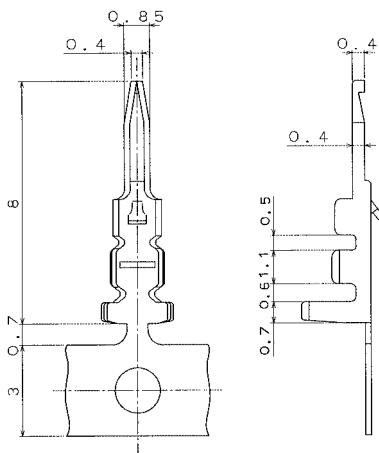

Part Number	CL No.	Packaging Type	Quantity	Finish	RoHS
DF2-2428PCF(05)	542-0020-0	Reel	10000	Tin plated	YES
DF2-2428PC(05)	542-0021-3	Bag	100	Tin plated	

●Applicable Cable (Tin plating annealed copper wire)

Conductor Size (Wire construction)	Jacket Diameter
AWG #24 (11cores. /0.16mm)	$\phi 0.9$ to $\phi 1.5$ mm
AWG #26 (7cores. /0.16mm)	
AWG #28 (7cores. /0.127mm)	

Note: If other cables are used instead of the applicable cable, contact Hirose sales department.

●Recommended Cable

UL1061, UL1007

●Strip Length

1.6 to 2.1mm

◆Applicable Crimping Tool

Type	Part Number	CL No.	Applicable Contact
Applicator	AP105-DF2-2428P	901-4506-1	DF2-2428PCF(05)
Main press unit	CM-105	901-0005-4	—————
Manual Crimping Tool	DF2-TA2428HC	550-0172-3	DF2-2428PC(05)
Extraction Tool	DF-C-PO(A)	550-0170-8	DF2-2428PCF(05)

Note: If any trouble has occurred due to other tools, which are not designated by Hirose, Hirose won't guarantee any products.

◆ Precautions

1. Recommended Soldering Condition	Flow: 250°C for 3 seconds Manual soldering: 290°C for 2 seconds ■ After the soldering process, if a load is applied to the cable in the state where the connector and the cable contains heat, the cable jacket holding members are apt to be loosened. Therefore, the post-soldering process should be carried out after the connector temperature returns to the room temperature.
2. Cleaning Condition	Refer to Nylon Connector Use Hand book. Don't use such a solvent as trichloroethane which degrades the cable jacket. In addition, avoid heat cleaning with such a solvent.
3. Connection Condition	Refer to Nylon Connector Use Hand book.
4. Precautions	Slight discoloration on the insulating materials will not affect form, fit or function of the connectors. Refer to "Nylon Connector Use Handbook".