

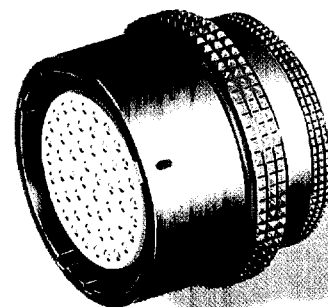

Motor Sport Connectors

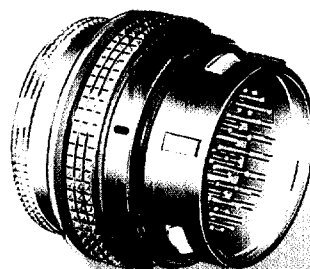
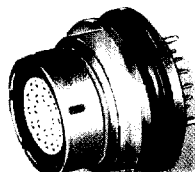
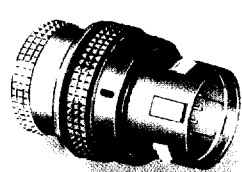

F SERIES
MOTORSPORT
CONNECTORS
FOR ENGINE
MANAGEMENT
AND DATA LOGGING.

THE QUALITY CHOICE

Table of contents

	General Production Programme	page 2
	Main Characteristics and Types	2
	LEMO's Push-Pull Self-Latching System	3
	Mechanical Connecting Characteristics	3
	Series and Types	4
General Characteristics	Outer Shell, Technical Characteristics	5
	Insulator, Technical Characteristics	6
	Contact, Technical Characteristics	6
	Cable fixing	8
Series F	Introduction	9
	Interconnections	9
	Model description	9
	Part Section Showing Internal Components	9
	Technical Characteristics	10
	Polarized Keying Systems	10
	Filtered connectors	10
	Part Number Example	11
	Models	12
	Type	14
Accessories	Crimp Contacts	15
	Heatshrink boot	15
	Insulating washers	15
	Conical nut	16
	Locking washers	16
	Hexagonal nuts	16
Tooling	Manual crimping tool	17
	Positioners for crimp contacts	17
	Extraction tools for crimp contacts	17
	Banding tool	17
	Panel cut-out	18
	PCB drilling pattern	18
	Termination of plug and receptacles	19

General Production Programme

Connectors

- Unipole from 2 to 150 Amps
- Coaxial 50 and 75 Ω
- Coaxial 50 Ω (NIM-CAMAC)
- Coaxial 50 Ω for frequency up to 12 GHz
- Coaxial 50 Ω SMA
- Multicoaxial 50 and 75 Ω
- Multipole from 2 to 106 contacts
- High Voltage 3, 5, 8, 10, 15, 30, and 50 kV dc
- Multi High Voltage 3, 5, and 10 kV dc
- Triaxial 50 and 75 Ω
- Quadrax
- Mixed: High Voltage (HV) + Low Voltage (LV)
- Mixed: Coax + LV
- Thermocouple
- Multithermocouple
- Fiber optic singlemode
- Fiber optic multimode
- Mixed: fiber optic + LV
- For OPTABALL® fiber optic singlemode
- Fluidic
- Multifluidic
- Mixed: fluidic + LV
- Subminiature
- Miniature
- Plastic
- Printed circuit board
- Remote handling
- Watertight
- Sealed (pressure and/or vacuum)
- With plastic outer shell
- With aluminum outer shell
- With stainless steel outer shell
- With special radiation resistant insulator material
- With screw thread coupling for very high pressure
- With microswitch



Patch Panels

- For audio-mono applications: triax or 3 contacts (with or without commutator)
- For audio-stereo applications: quadrax or 6 contacts
- For video applications: coax 75 Ω
- For video HDTV applications: 3 coax 75 Ω + 2LV
- For fiber optic applications

Accessories

- Insulator for crimp contacts
- Crimp contacts
- Coaxial contacts
- Fiber optic contacts
- Fiber optic ferrules
- Caps
- Heatshrink boot
- Insulating washers
- Double plastic panel washers
- Locking washers
- Tapered washers
- Hexagonal nuts
- Round nuts
- Conical nuts
- Earthing washers
- Lead-through with cable collet

Tools

- Spanners
- Crimping tools
- Positioners
- Crimping dies
- Extractors
- Banding tool
- Fiber optic termination workstation
- Fiber optic polishing tools

On request

- Filtered connectors
- Connectors with special alloy housing
- Mixed special connectors
- Assembly onto cable

• Connectors, accessories, and tools found in this catalog.

Adaptors

- For BNC, C, UHF, N, CINCH connectors
- For GEN-RADIO, SMA connectors
- For TNC connectors

Main Characteristics and Types

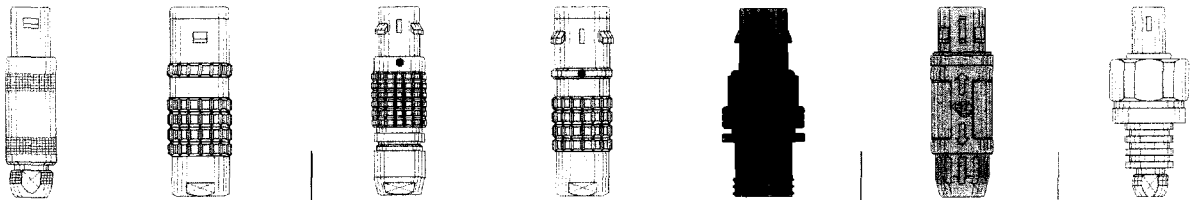

Series	Series 1	Series 2	Series 3	Series 4	Series 5	Series 6	Series 7
Latching	No						Screw
Key	Stepped insert (Half-Moon)	No		No		No	No
Shell	Metal or plastic			Metal		Plastic	Metal
Insert	Stepped insert (Half-Moon)		Cylindrical				
Contact	Solder or Print		Solder				

LEMO's Push-Pull Self-Latching Connecting System

This self-latching system is renowned worldwide for its easy and quick mating and unmating features. It provides absolute security against vibration, shock or pull on the cable, and facilitates operation in a very limited space.

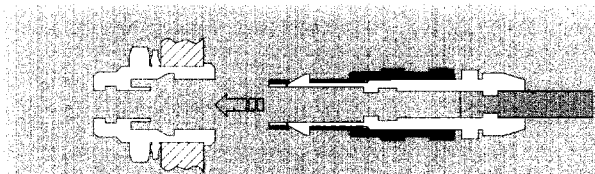

The LEMO self-latching system allows the connector to be mated by simply pushing the plug axially into socket.

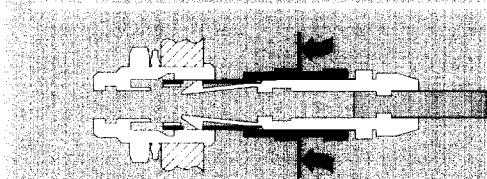

Once firmly latched, connection cannot be broken by pulling on the cable or any other component part other than the outer release sleeve.



When required, the connector is disengaged by a single axial pull on the outer release sleeve. This first disengages the latches and then withdraws the plug from the socket.

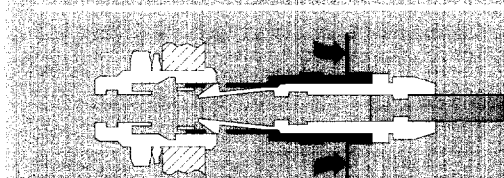

Mechanical Connecting Characteristics

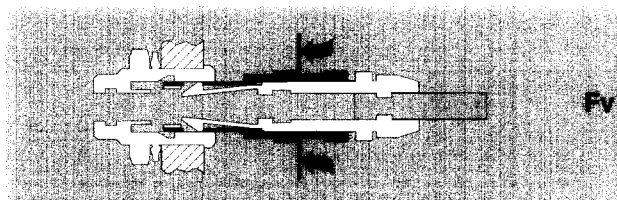

F_v

F_v: average latching force.

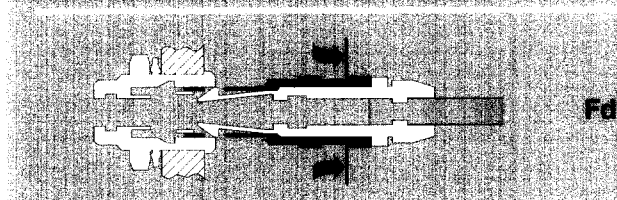

F_d

F_d: average unmating force with axial pull on the outer release sleeve.

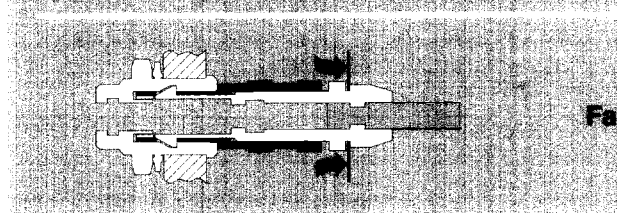

F_a

F_a: average pull force with axial pull on the collet nut.

Notes: the forces were measured on outer shells not fitted with contacts. The mechanical endurance represents the number of cycles after which the latching system is still effective (1 cycle = 1 latching/unlatching – 300 cycles per hour).
 Mechanical endurance: 5000 cycles.
 The values were measured according to the standard MIL-STD-1344A method 2013.1.

1N = 0,102 kg.

	Series					
	0F	1F	2F	3F	4F	5F
	6	6	8	9	14	21
	8	8	9	11	16	24
	150	150	150	150	150	150

Series and Types

		Types																					
		Unipole	Coaxial 50 Ω	Coaxial 75 Ω	Multipole	High Voltage	Triaxial 50 Ω	Triaxial 75 Ω	Quadrad	Multi High Voltage (Keyed series)	Multi High Voltage	Multi Coaxial	Mixed HV + LV	Mixed Coax + LV	Mixed Triax + LV	Fiber Optic (single fiber)	Multi Fiber Optic	Mixed FO + LV	Fluidic	Multifluidic	Mixed fluidic + LV	Thermocouple	
Standard			•																				
		•	•				•												•				
			•	•																			
		•	•	•	•	•	•	•															•
		•	•	•	•	•	•	•	•														•
		•	•	•	•	•	•	•	•														•
		•	•	•	•	•	•	•	•														•
		•	•	•	•	•	•	•	•														•
Watertight		•	•	•	•	•	•	•														•	
		•	•	•	•	•	•	•														•	
Keyed					•	•	•	•									•					•	
					•	•	•	•		•	•	•	•	•	•	•	•	•	•	•	•	•	
Keyed Watertight					•	•	•	•														•	
				•	•	•	•	•		•	•	•	•	•	•	•	•	•	•	•	•	•	
Plastic				•									•	•					•				
Screw		•	•	•	•	•	•	•														•	
		•	•	•	•	•	•	•														•	
		•	•	•	•	•	•	•														•	
		•	•	•	•	•	•	•														•	

General Characteristics - F Series



Outer Shell

Aluminum Alloy

Aluminum alloy outer shells find numerous applications where light weight is a predominant factor; such as in the aeronautics, motor racing and space industries, or for portable and mobile equipment.

We have selected very high mechanical strength (Avional) alloys to meet requirements of the highly demanding applications. The connector shells are protected by a conductive anthracite colored nickel finish.

Sealing gasket

Sealing gasket and gland are moulded from fluorosilicone rubber. Such material is designed for use where contact with jet fuel, solvent or crude oil is required.

Sealing resin

To seal both watertight or vacuumtight models we use an epoxy resin.

Materials and Treatment

	Material	Surface treatment (µm)	
		Cu	Ni
	Avional	-	5 ¹⁾
	Avional	Anodized ²⁾	
	Bronze (UNS C 54400) ³⁾	0.5	3
	Special brass	0.5	10 ¹⁾
	Bronze (UNS C 52100)	0.5	3
	Aluminum alloy (AA 6012)	Anodized	
	Brass (UNS C 38500)	0.5	3
	Fluorosilicone (FVMQ)	-	
	Fluorosilicone (FVMQ)	-	
	Epoxy	-	

Note: 1) Anthracite color
2) various colors
3) Brass (UNS C38500) for 5F series

Electrical Characteristics

Screen continuity

(according to test MIL-STD-1344A, method 3007).

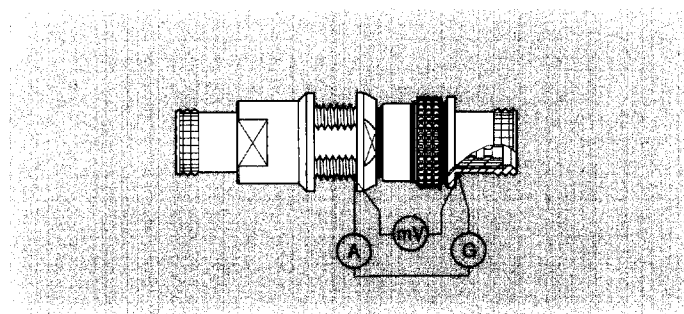

R_1 Values with earthing crown and latch sleeve or nickel plated.

Series	R_1 (mΩ)
0F	5.0
1F	3.0
2F	2.5
3F	2.5
4F	2.0
5F	1.5

Testing current: 1A
A = Ammeter
mV = Millivoltmeter
G = Generator

Screen efficiency

(according to the standard IEC 169-1-3).

Screen efficiency is a value representing the ratio between the electromagnetic field inside a connector and the one emitted outside it.

Construction of the LEMO connectors with metallic outershell and earthing crown insure optimal screen efficiency performances in applications where electromagnetic compatibility (EMC) is critical.

Typical values of screen efficiency are the following when measured in the frequency range 10 kHz to 1 GHz:

$f = 10 \text{ MHz} < 70 \text{ dB}$; $f = 300 \text{ MHz} < 50 \text{ dB}$.



Insulator

Plastic materials used by LEMO for production of insulators are selected according to the thermal and electrical properties requested by the different types of connectors.

Properties considered for both types are the following:

- dielectric strength
- tracking-current resistance
- surface and volume resistivity
- long term service temperature
- water absorption
- radiation resistance
- flammability
- hydrocarbon resistance

LEMO uses PEEK (Polyether Etherketone) for the insulator material. The performance of this thermoplastic material is enhanced by the addition of glass fibers in the resin to achieve very high mechanical strength, to increase dielectric strength and to reduce water absorption rate. The above features of PEEK plus its excellent chemical and radiation resistance makes it ideal for most applications.

Sealing grommet are moulded from FVMQ (fluorosilicone) rubber. Such polymer has inherently excellent electrical insulating properties which does not change when exposed to adverse environments.

Insulating resistance $>10^{12} \Omega$ (per MIL-STD-1344A method 3003.1)

Radiation resistance

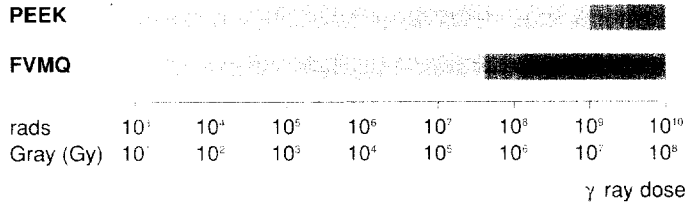

- Damage**
- minimal to mild (almost always usable)
 - mild to moderate (often satisfactory)
 - moderate to severe (unusable)

Technical Characteristics

	Test method	Unit	PEEK	FVMQ
	ASTM D 149 / IEC 243	kV/mm	19 - 25	18
	ASTM D 257 / IEC 93	$\Omega \cdot \text{cm}$	10^{16}	10^{15}
	ASTM D 257 / IEC 93	Ω	10^{15}	
	ASTM C 177	W/K · m	0.25	170
	IEC 112	V	CTI 150	
	ASTM D 150 / IEC 250	-	3.2 - 3.5	3
	ASTM D 150 / IEC 250	-	< 0.005	0.01
	-	°C	250	200
	-	°C	300	220
	-	°C	-50	-50
	ASTM D 570 / ISO 62	%	< 0.3	0
	-	Gy	10^7	$5 \cdot 10^5$
	(UL 94)	-	V-0/3.2	-

Note: the technical data contained in this chapter gives a general information about plastic materials used by LEMO as electrical insulator materials. LEMO reserves the right to propose new material which would have higher technical characteristics and to withdraw any material contained in this publication or others from LEMO and its subsidiary companies. LEMO only uses granulated, powdered plastic materials or bars from specialized suppliers. LEMO is not responsible, in any case, for these materials.



Electrical Contact

Technical Description

The secure, reliable electromechanical connection achieved with LEMO female contacts is mainly due to two important design features:

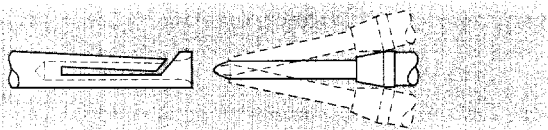

1. **Prod proof entry** which ensures perfect concentric mating even with well used and/or carelessly handled connectors.
2. **The pressure spring** that maintains a constant, even force on the male contact when mated. The leading edge of the spring is chamfered to slide smoothly on the male contact, preserving the gold-plated surface treatment and preventing undue wear.

Contact Material

LEMO female electrical contacts are made from bronze (UNS C 54400). Bronze is chosen because of its high modulus of elasticity, its excellent electrical conductivity and a high mechanical strength.

LEMO male solder and print contacts are made from brass (UNS C 38500). Male crimp contacts are made from brass (UNS C 34500) or annealed brass (UNS C 38500) which is ideal for crimping onto the electrical conductor.

Materials and Treatments

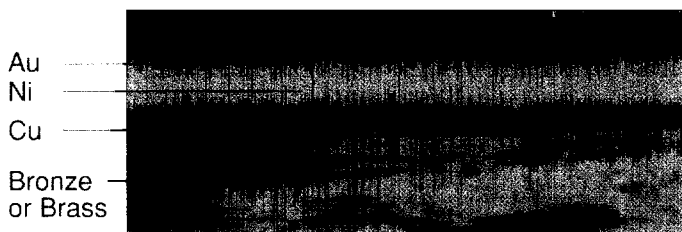

Notes: the standard surface treatments are as follows:

- Nickel QQ-N-290A or MIL-C-26074C
- Gold MIL-G-45204C, type I, class 1.

¹⁾ Minimum value

Conductor retention method

Both male and female contacts are available in crimp or solder versions or print for PCB mounting.

	Material (Standard)	Surface treatment (µm)		
		Cu	Ni	Au
	Brass (UNS C 38500)	0.5	3	1.3 ¹⁾
	Brass (UNS C 34500)			
	Brass (UNS C 38500)			
	Brass (UNS C 38500)			
	Bronze (UNS C 54400)	0.5	3	2.0
	Bronze (UNS C 54400)			
	Cu-Be (UNS C 17200)			
	Cu-Be (UNS C 17200)	-	-	-
	Stainless steel (Durinox)	-	-	-

Thickness comparison between the outside and the inside of female contacts

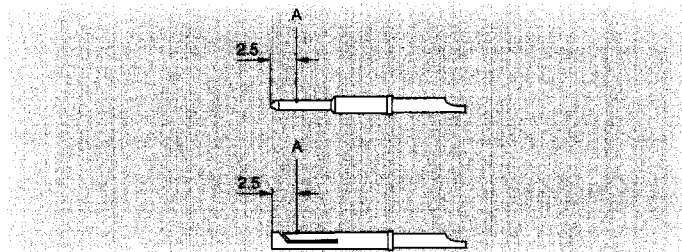

Contact ø (mm)	Gold thickness		
	male (µm)	female	
		outside (µm)	inside (%)
1.3	1.3	2	65
0.9	1.3	2	65
0.7	1.3	2	60

Note: A = test point

Crimp Contacts

The crimp method requires a controlled compression to obtain a symmetrical deformation of the strands of the conductor and of the material of the contact.

The radial hole in the side of the contact enables correct positioning of the conductor with the contact to be verified. The LEMO crimp contacts are factory annealed to relieve internal stresses, and reduce the risk of the material work hardening during the crimping process.

Features of the LEMO crimp contacts:

- Quick and simple assembly
- Insulator is not heated during contact to conductor assembly
- High temperature applications possible
- Increased conductor retention force

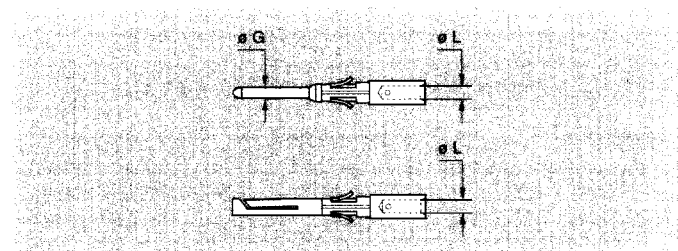

Contact		Conductor				F _r (N)
ø G (mm)	ø L (mm)	AWG		Section (mm ²)		
		min.	max.	min.	max.	
1.3	1.4	22	18	0.34	1.00	40
0.9	1.1	24 ²⁾	20	0.22	0.50	30
0.7	0.8	26 ²⁾	22 ¹⁾	0.14	0.34	22

Note: F_r: contact retention force.

¹⁾ The variance in conductor strandings which are quoted as being a specific AWG is so large that it may not be possible to achieve crimp as per MIL-C-225201-01. The conductor size should be verified against the contact diameter L before proceeding.

²⁾ Only for stranded constructions.

Solder Contacts

The conductor bucket of these contacts is machined at an angle to form a cup into which the solder can flow.

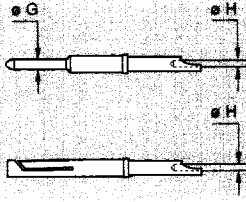

Contact		Conductor			
ø G (mm)	ø H (mm)	Solid		Stranded	
		AWG max.	Section (mm ²)	AWG max.	Section (mm ²)
1.3	1.0	20	0.50	20 ¹⁾	0.50
0.9	0.8	22	0.34	22 ¹⁾	0.34
0.7	0.8	22	0.34	22 ¹⁾	0.34

Note: ¹⁾ The variance in conductor strandings which are quoted as being a specific AWG is so large that it may not be possible to achieve crimp as per MIL-C-225201-01. The conductor size should be verified against the contact diameter H before proceeding. Only available for EGN and EEN.

Print contacts

Print contacts are available as a standard for the PCB receptacles. Connection is made on flexible or rigid printed circuits by soldering.

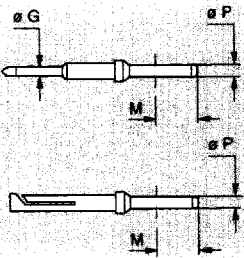

Contact		
ø G (mm)	ø P (mm)	M (mm)
1.3	0.5	4
0.9	0.5	4
0.7	0.5	4

Contact Resistance in Relation to Numbers of Mating Cycles

(Corrosion according to MIL-STD-202, method 101D).

Contact ø (mm)	Contact resistance (mΩ)		
	1000 cycles	3000 cycles	5000 cycles
1.3	2.8	2.9	3.6
0.9	4.1	4.2	4.8
0.7	5.6	5.7	6.1

Information on Voltage and Current Rating

Working Voltage

(according to standard IEC 130-1 first issue § 14.5)

Test voltage (U_e):
Corresponds to 75 % of the average voltage when a breakdown occurs by flashing or perforation of the insulator. Minimum test voltage specified is 500 V and test duration is 1 minute.

Working voltage (U_s):
Is defined according to the following relation: $U_s = \frac{U_e}{3}$

Warning:
For numerous applications the safety requirements that electrical apparatus must meet dictate more restrictive working voltages. Working voltages are then defined according to the distances between contacts. Please consult us when choosing your connector and indicate the safety standard that your product must satisfy.

Values are shown on the tables for the insulator types. They correspond to values measured at sea level.

Rated Current

(according to standard IEC 512-3)

The rated current specified can be applied to all contacts simultaneously. It corresponds to a 40°C average warming of the insulator when material is used at ambient temperature. With a use at higher temperatures the permissible rated current will be reduced. It tends to zero when material is used at the maximum permissible working temperature.

Warning:

As a general rule connectors should not be disconnected under charge when they are used at high current.

Values are shown on the tables for the insulator types.



Cable fixing

In order to reduce density, this connector series does not include clamping collets. Cable resistance is insured by "tie-wrap" junction of the cable screen on the connector outershell and the thermofit jacket.

LEMO F Series Push-Pull Connectors

The new F Series of push-pull connectors has been specifically developed to meet requirements of the highly demanding motor racing industry for both engine management and data logging.

Based upon the proven LEMO self-latching system this new range of connectors provides customers with many features and benefits including the following:

- Scoop-proof push-pull self-latching system for quick, safe and easy connection
- Highly compact design for space saving
- Very low weight by use of aluminum alloys
- Easy and fast cable assembly due to the limited number of components
- Gold plated crimp, solder or print contacts
- Sealed to IP67 for environmental protection when mated
- Special keying arrangement allowing blind-mating
- 6 different sizes with 3 to 64 contacts configurations
- High shock and vibration resistance
- Color coded key options for system security
- Conductive anthracite nickel finish
- Choice of 8 models including fixed, straight, flange or PCB mounted receptacles
- Filtered versions available on request

Interconnections

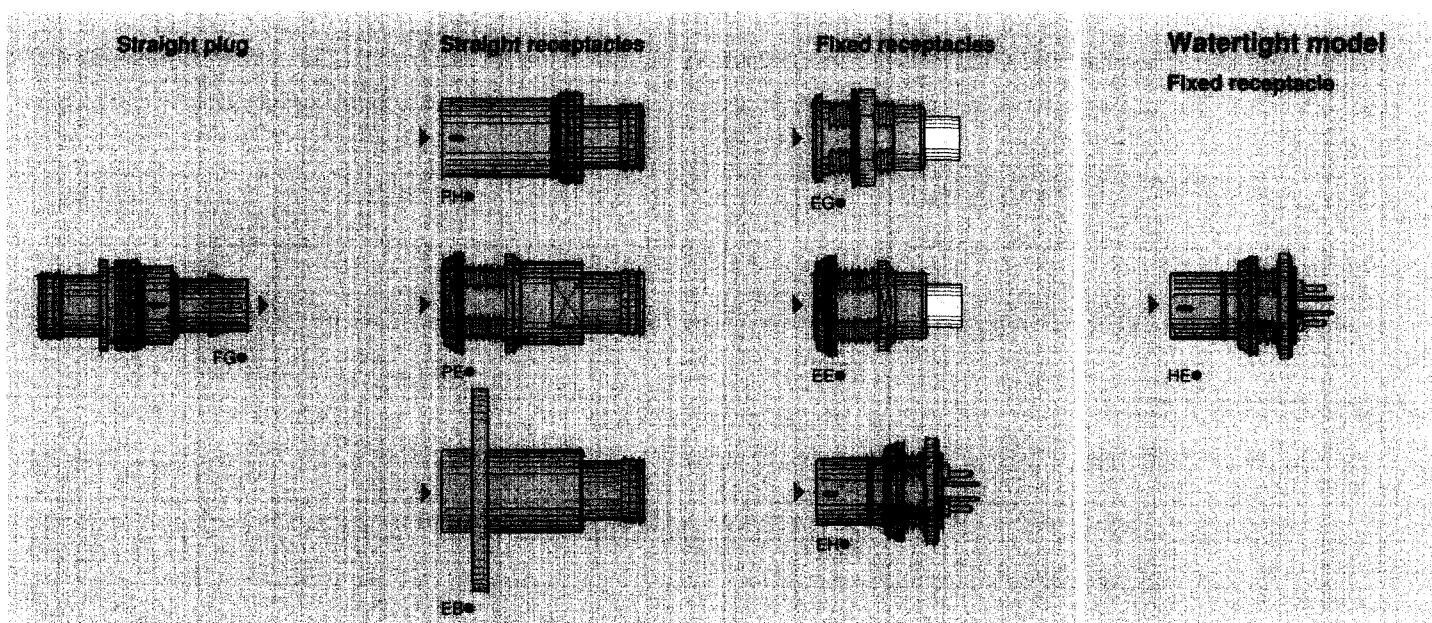

Model description

- | | |
|--|---|
| <ul style="list-style-type: none"> EB • Straight receptacle with flange and keys (code N, P, S, W or X), 2 holes fixing EE • Fixed receptacle, nut fixing, with keys (code N, P or S), (back panel mounting) EG • Fixed receptacle, nut fixing, with keys (code N, P or S) EH • Fixed receptacle, nut fixing, with keys (code N, P, S, W or X), (back panel mounting), for PCB mount | <ul style="list-style-type: none"> FG • Straight plug with keys (code N, P, S, W or X) HE • Fixed receptacle, nut fixing, with keys (code N, P, S, W or X), (back panel mounting), for PCB mount, IP 66 PE • Straight receptacle, nut fixing, with keys (code N, P, S, W or X), (back panel mounting) PH • Straight receptacle with keys (code N, P, S, W or X) |
|--|---|

Part Section Showing Internal Components

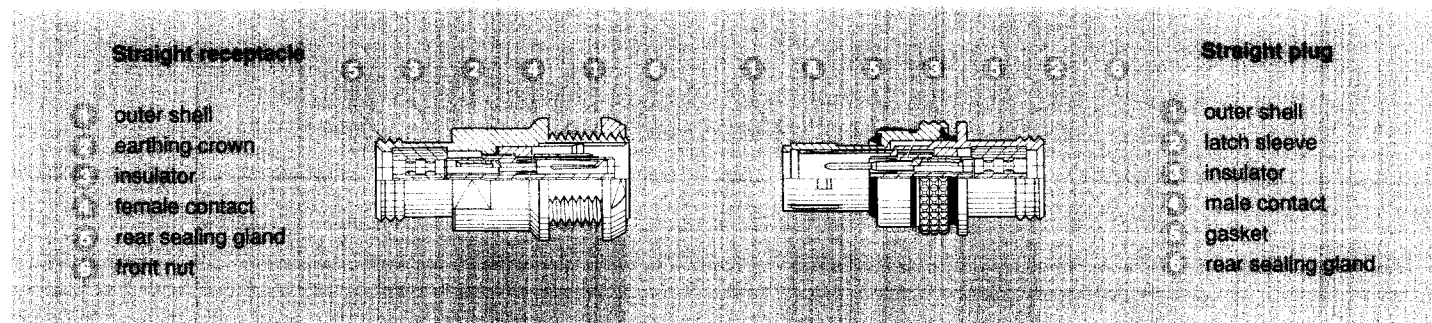

Technical Characteristics

Mechanical and climatical

	Value	Standard	Method
	> 1000 cycles	MIL-STD-1344A	2016
	up to 95% to 60° C		
	-50° C, +200° C		
	good	MIL-STD-1344A	2005.1
	good	MIL-STD-1344A	2004.1
	IP67	IEC 529	

Polarized Keying Systems

Plug (front view)	Nb of key	Series 0F to 2F		Series 3F		Color code	Type of contact		Note
		Angles					Plug	Receptacle	
		α	γ	α	γ				
●●N	3	165°	30°	150°	60°	blue	male	female	●
●●P		150°	60°	145°	70°	yellow	male	female	○
●●S		155°	50°	140°	80°	red	female	male	○

Plug (front view)	Nb of key	Series 4F-5F				Color code	Type of contact		Note
		Angles					Plug	Receptacle	
		α	β	γ	δ				
●●W	5	115°	95°	25°	35°	blue	male	female	●
●●X		125°	100°	20°	40°	red	female	male	○

● Available
○ On request

Filtered connectors

On request some models are available with filter for use wherever electromagnetic interference (EMI) suppression is required.

Using a combination of planar-array and ferrite-bead technology these connectors can incorporate C, L-C, T or Pi filter configuration according to specific needs regarding the frequency of the signal, the circuit impedance or the expected insertion loss at a given frequency.

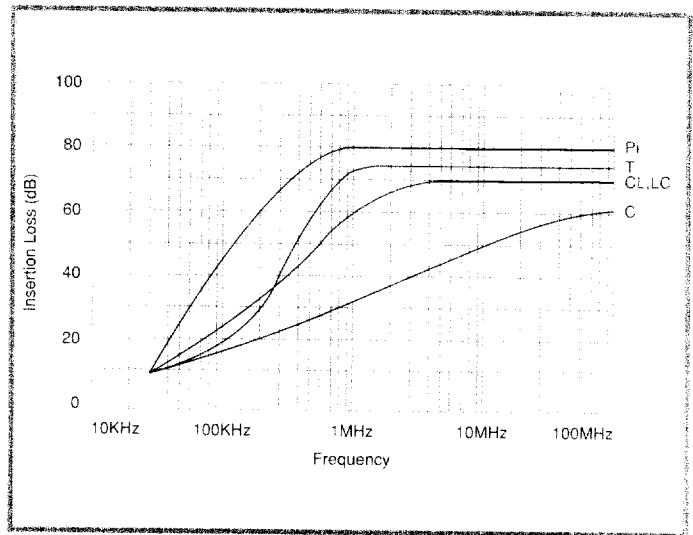
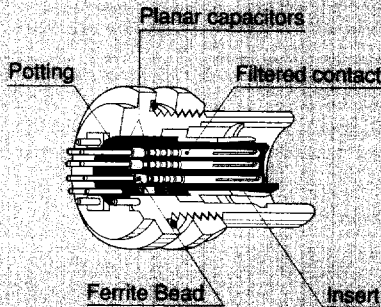

Part Number Example

Straight plug

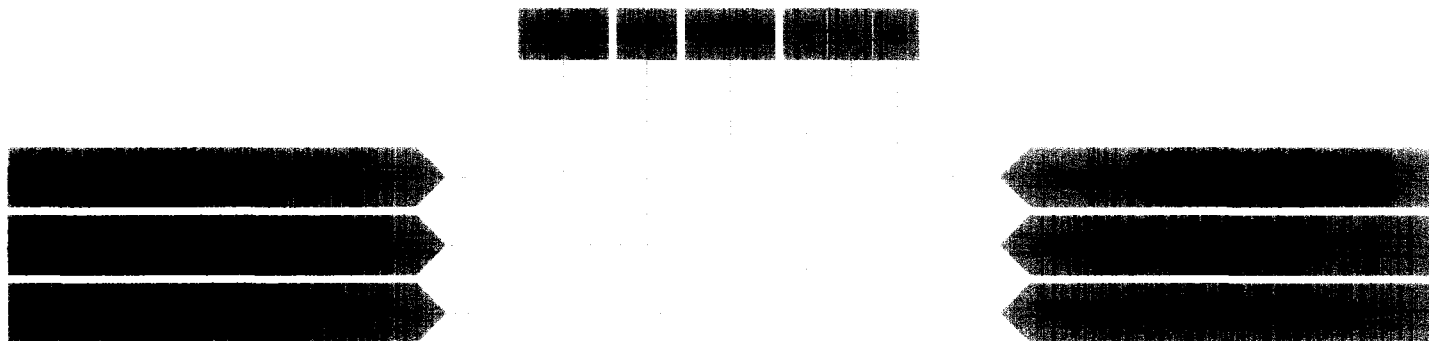

FGN.0F.305.XLC = Straight plug, with keys (code N), 0F series, 5 contacts type, Avional outer shell, PEEK insulator, male contacts to crimp.

Straight receptacle

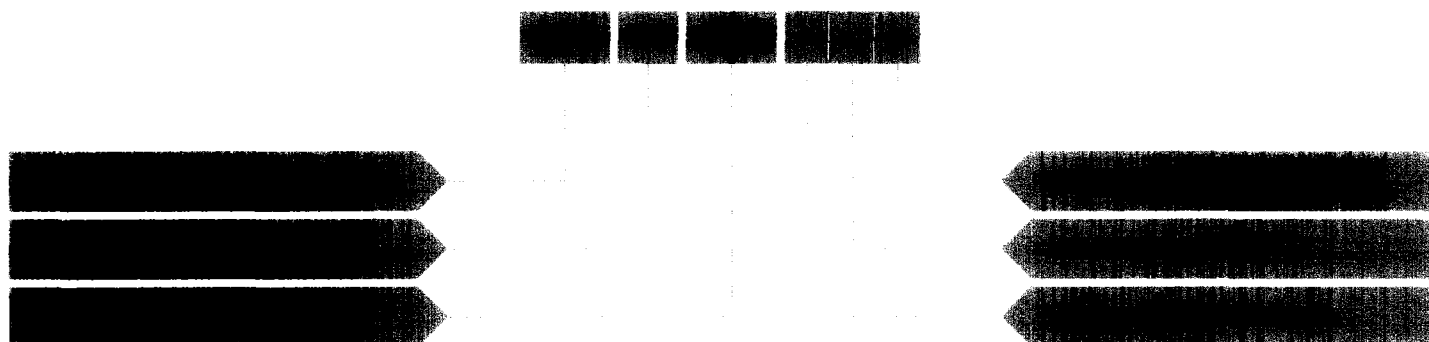

PEN.2F.310.XLM = Straight receptacle, with keys (code N), (back panel mounting), 2F series, 10 contacts type. Avional outer shell, PEEK insulator, female contacts to crimp.

Fixed receptacle

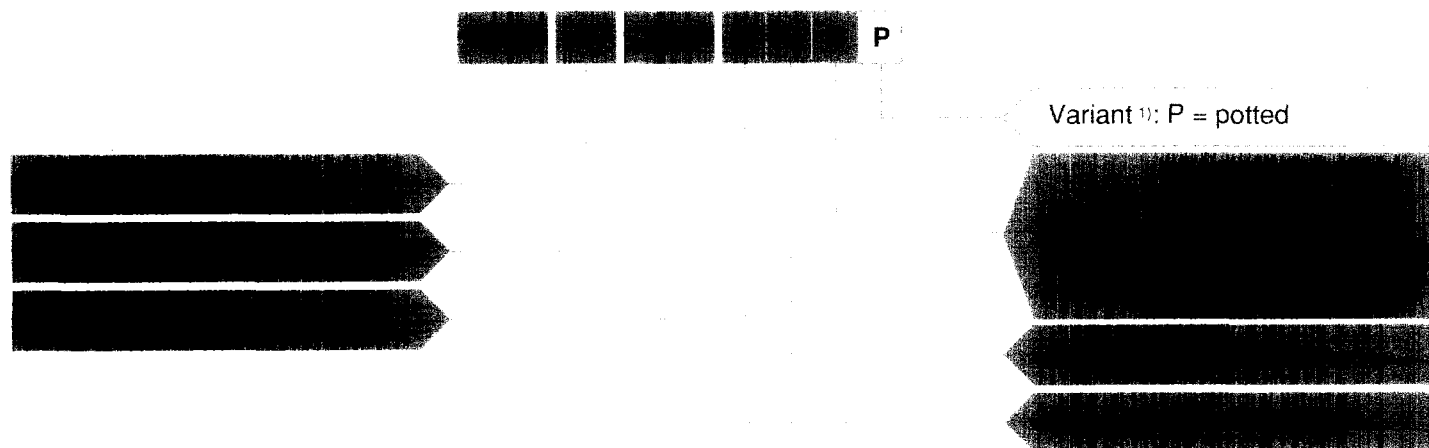

HEN.1F.307.XLNP = Fixed receptacle with nut fixing and keys (code N), (back panel mounting), IP 66, 1F series, 7 contacts type, Avional outer shell, PEEK insulator, female contacts to print, potted.

1) Potting for HEN only.

2) HEN available only in male or female to print.

Models - Series

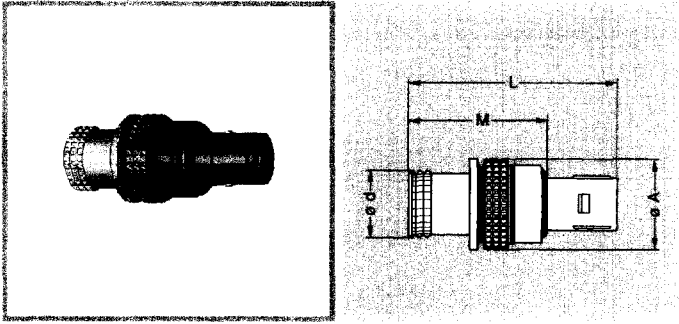

FGN Straight plug with keys (code N, P, S, W or X)

Series	Dimensions (mm)			
	A	d	L	M
0F	12	9.0	27.5	18.0
1F	14	10.7	27.5	18.1
2F	17	14.0	27.5	18.2
3F	19	16.0	27.5	18.2
4F	26	21.2	30.0	20.8
5F	35	30.2	30.0	20.8

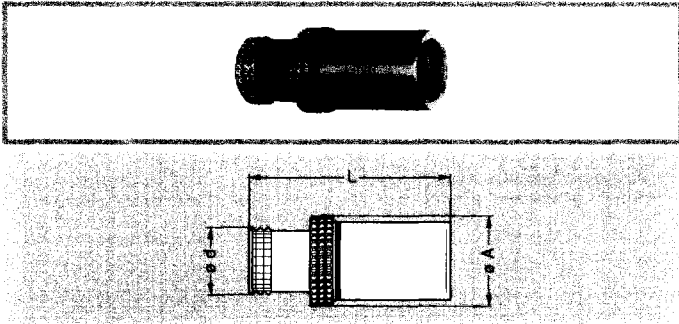

PHN Straight receptacle with keys (code N, P, S, W or X)

Series	Dim. (mm)		
	A	d	L
0F	12	9.0	26.7
1F	14	10.7	26.7
2F	17	14.0	26.7
3F	19	16.0	26.7
4F	26	21.2	26.7
5F	35	30.2	26.7

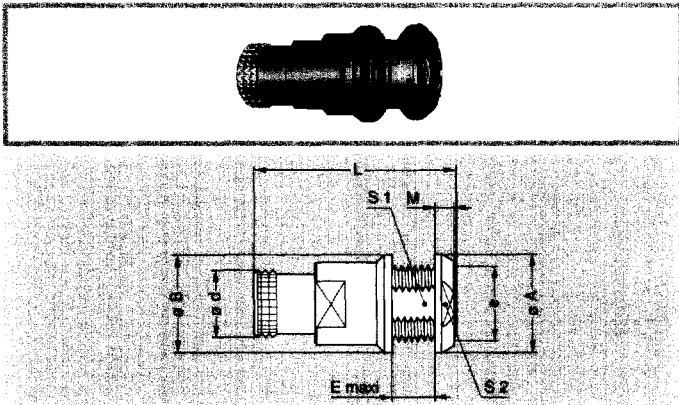

PEN Straight receptacle, nut fixing, with keys (code N, P, S, W or X), (back panel mounting)

Series	Dimensions (mm)									
	A	B	d	e	E	L	M	S1	S2	
0F	13	13	9.0	M10x0.75	6.0	26.7	2.5	9.0	11	
1F	17	17	10.7	M13x0.75	6.2	26.7	3.2	11.5	14	
2F	20	20	14.0	M16x1.00	6.4	26.7	4.0	14.5	17	
3F	22	22	16.0	M18x1.00	6.4	26.7	4.0	16.5	19	
4F	29	29	21.2	M24x1.00	6.4	26.7	5.0	22.0	25	
5F	38	38	30.2	M33x1.00	6.4	26.7	5.0	31.0	34	

P1 Panel cut-out

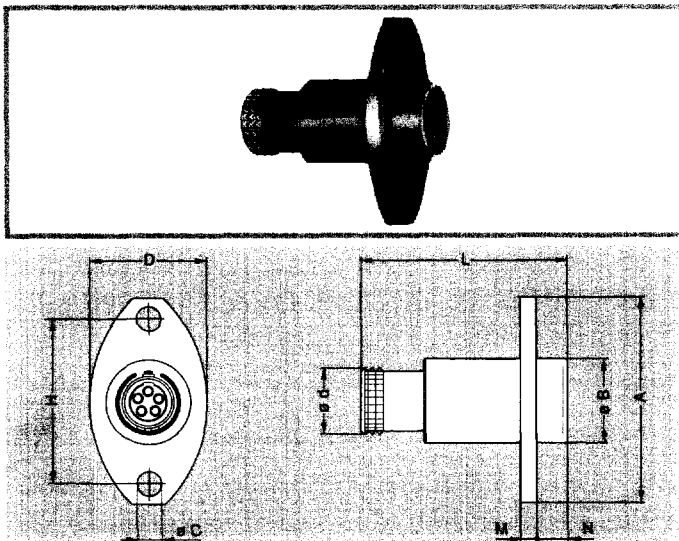

EBN Straight receptacle with flange and keys (code N, P, S, W or X), 2 holes fixing

Series	Dimensions (mm)								
	A	B	C	d	D	H	L	M	N
0F	27	11	3.2	9.0	18	21.4	26.7	2	4
1F	27	13	3.2	10.7	15	21.4	26.7	2	4
2F	32	16	3.2	14.0	18	25.9	26.7	2	4
3F	38	18	3.2	16.0	20	32.5	26.7	2	4
4F	41	23	3.2	21.2	26	34.8	26.7	2	4
5F	44	32	3.2	30.2	33	38.2	26.7	2	4

P2 Panel cut-out

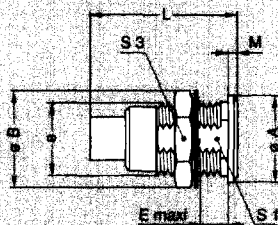
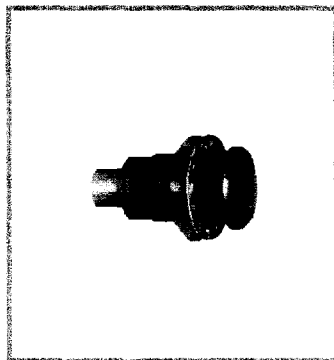

EGN Fixed receptacle, nut fixing, with keys (code N, P or S)

Series	Dimensions (mm)								
	A	B	e	E	L	M	S1	S3	
0F	10	12.5	M9x0.6	7	19	1.2	8.2	11	
1F	14	16.0	M12x1.0	7	19	1.5	10.5	14	
2F	18	19.5	M15x1.0	6	19	1.8	13.5	17	
3F	22	25.2	M18x1.0	5	19	2.0	16.5	22	

P1 Panel cut-out

Note: EGN in 4F and 5F series are available on request.

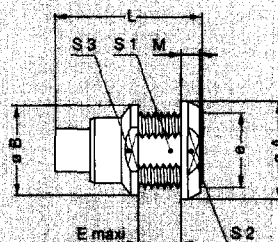
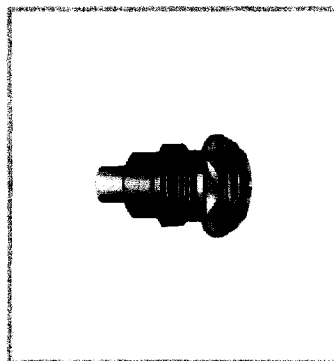

EEN Fixed receptacle, nut fixing, with keys (code N, P or S), (back panel mounting)

Series	Dimensions (mm)									
	A	B	e	E	L	M	S1	S2	S3	
0F	13	12	M10x0.75	6.0	19	2.5	9.0	11	10.5	
1F	17	15	M13x0.75	6.2	19	3.2	11.5	14	14.0	
2F	20	19	M16x1.00	6.4	19	4.0	14.5	17	16.0	
3F	22	22	M18x1.00	6.4	19	4.0	16.5	19	20.0	

P1 Panel cut-out

Note: EEN in 4F and 5F series are available on request.

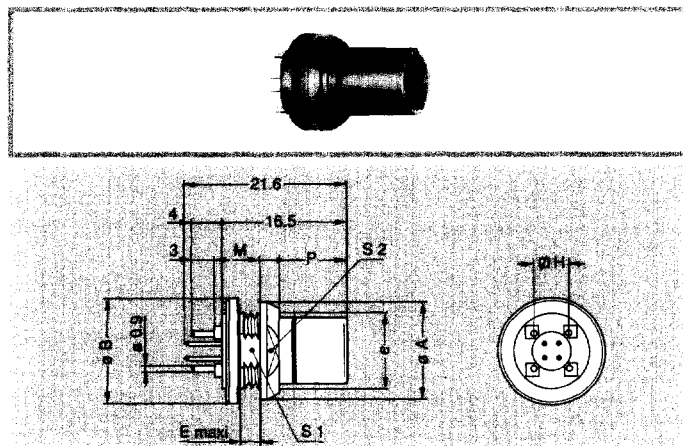

EHN Fixed receptacle, nut fixing, with keys (code N, P, S, W or X), for PCB (back panel mounting)

Series	Dimensions (mm)									
	A	B	e	E	H	M	P	S1	S2	
0F	13	14	M10x0.75	3	5.08	2.5	9.0	9.0	11	
1F	17	17	M13x0.75	3	7.62	3.2	8.3	11.5	14	
2F	20	20	M16x1.00	3	8.89	4.0	7.5	14.5	17	
3F	22	23	M18x1.00	3	11.43	4.0	7.5	16.5	19	
4F	29	29	M24x1.00	3	15.24	5.0	6.5	22.0	25	
5F	38	38	M33x1.00	3	20.32	5.0	6.5	31.0	34	

P1 Panel cut-out

P3 PCB drilling layout

Watertight model

The HEN fixed socket allow the device on which they are fitted to reach a protection index of IP 66 as per IEC 529 (unmated). They are fully compatible with all non-watertight models of the same series.

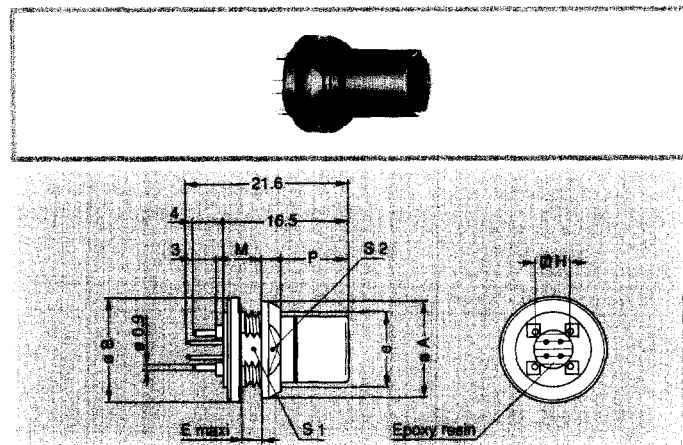

HEN Fixed receptacle, nut fixing, with keys (code N, P, S, W or X), for PCB (back panel mounting), IP 66

Series	Dimensions (mm)									
	A	B	e	E	H	M	P	S1	S2	
0F	13	14	M10x0.75	3	5.08	2.5	9.0	9.0	11	
1F	17	17	M13x0.75	3	7.62	3.2	8.3	11.5	14	
2F	20	20	M16x1.00	3	8.89	4.0	7.5	14.5	17	
3F	22	23	M18x1.00	3	11.43	4.0	7.5	16.5	19	
4F	29	29	M24x1.00	3	15.24	5.0	6.5	22.0	25	
5F	38	38	M33x1.00	3	20.32	5.0	6.5	31.0	34	

P1 Panel cut-out

P3 PCB drilling layout

Type

Multipole

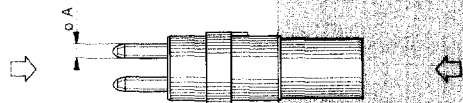

			Contact number	ϕA (mm)	AWG	Operating voltage (kV rms) ¹⁾	Operating voltage (kV dc) ¹⁾	Test voltage (kV rms) ¹⁾	Test voltage (kV dc) ¹⁾	Rated current (A)
0F			3	0.9	20-22-24	0.42	0.60	1.3	1.8	8.0
			4	0.7	22-24-26	0.46	0.66	1.4	2.0	7.0
			5	0.7	22-24-26	0.26	0.40	0.8	1.2	6.5
1F			3	1.3	18-20-22	0.42	0.60	1.3	1.8	12.0
			5	0.9	20-22-24	0.46	0.66	1.4	2.0	9.0
			7	0.7	22-24-26	0.46	0.66	1.4	2.0	7.0
			8	0.7	22-24-26	0.40	0.60	1.2	1.8	5.0
2F			8	0.9	20-22-24	1.00	1.50	3.2	4.5	10.0
			10	0.9	20-22-24	0.56	0.83	1.7	2.5	8.0
			12	0.7	22-24-26	0.56	0.83	1.7	2.5	7.0
			19	0.7	22-24-26	0.46	0.66	1.4	2.0	5.0
3F			22	0.7	22-24-26	0.40	0.56	1.2	1.7	5.5
4F			40	0.7	22-24-26	0.56	0.80	1.7	2.4	2.0
5F			50	0.9	20-22-24	0.76	1.10	2.3	3.3	6.0
			54	0.9	20-22-24	0.76	1.10	2.3	3.3	5.0
			64	0.9	20-22-24	0.53	0.70	1.6	2.3	3.0

Note: ¹⁾ see information page 8.
 other type available on request, based on existing contact configuration of the B series.

Accessories

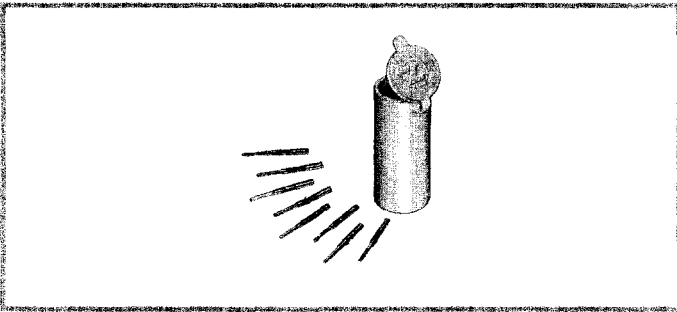

Crimp Contacts

	Contact Ø	Contact part number	
		Male	Female
0F-1F	1.3	FGN.1F.565.ZZC	EGN.1F.565.ZZM
	0.9	FGG.0B.560.ZZC	EGG.0B.660.ZZM
2F-3F	0.7	FGG.0B.555.ZZC	EGG.0B.655.ZZM
	0.9	FGG.2B.560.ZZC	EGG.0B.660.ZZM
4F-5F	0.7	FGG.2B.555.ZZC	EGG.0B.655.ZZM

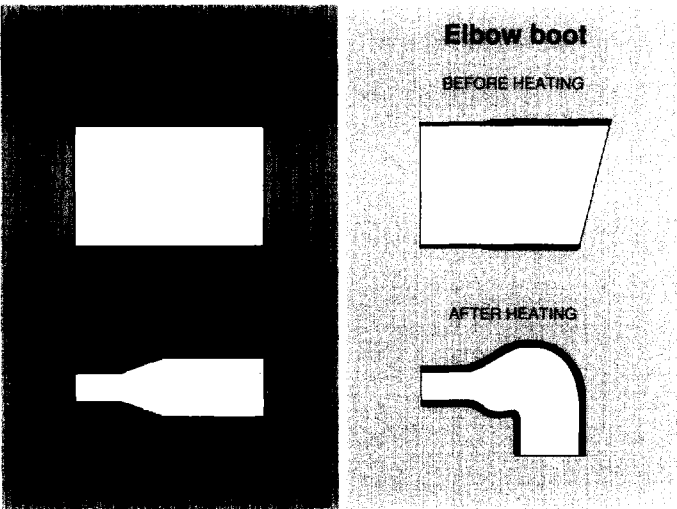

Heatshrink boot

Supplier	Elbow 90°
Raychem®	222 A series
Hellerman Electric®	1100 series

☉ Material: Polyolefin.

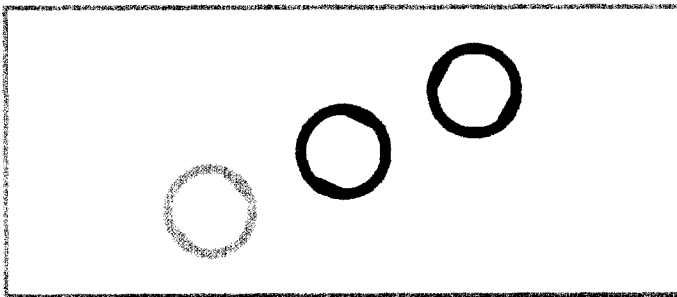

GRA Insulating washers

Series	Dimensions (mm)					
	A	B	E	L	M	T
0F	15	12.0	4	1.8	1.0	11
1F	19	15.0	4	2.0	1.1	14
2F	22	18.5	4	2.2	1.2	17
3F	24	20.5	4	2.2	1.2	19
4F	31	27.5	4	2.2	1.2	25
5F	40	36.5	4	2.2	1.2	34

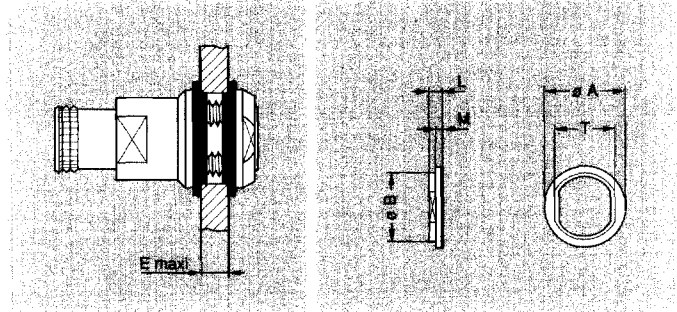

Color	Keying
blue	N-W
yellow	P
red	S-X

Note: The last position "●" of the part number indicates the color. To obtain the color required, refer to the table above and change the position "●" of the part number to the corresponding letter.

☉ Material: Polyamid (PA.6)

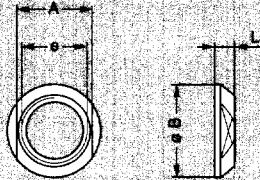
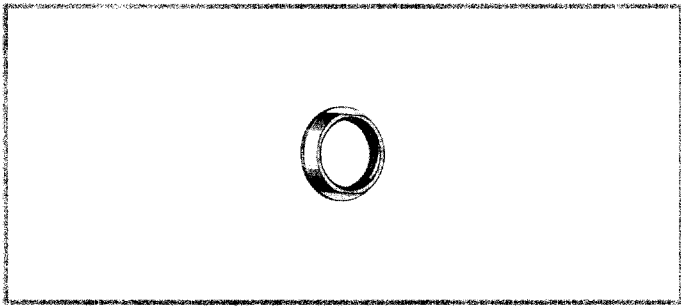

GEC Conical nut

Series	Dimensions (mm)				Weight (g)
	A	B	e	L	
0F	11	13	M10x0.75	2.5	0.3
1F	14	17	M13x0.75	3.2	0.6
2F	17	20	M16x1.00	4.0	1.0
3F	19	22	M18x1.00	4.0	1.1
4F	25	29	M24x1.00	5.0	1.5
5F	34	38	M33x1.00	5.0	2.0

Color	Keying
blue	N-W
yellow	P
red	S-X

Note: The last position "●" of the part number indicates the color. To obtain the color required, refer to the table and change the position "●" of the part number to the corresponding letter.

● Material: Avional

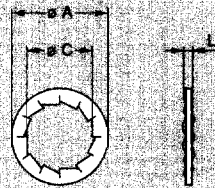
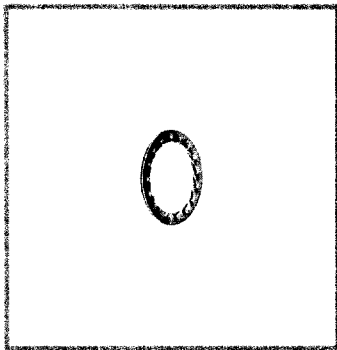

GBA Locking washers

Series	Dimensions (mm)			Weight (g)
	A	C	L	
0F	12.5	9.1	1.0	0.3
1F	16.0	12.1	1.0	0.4
2F	19.5	15.1	1.2	0.6
3F	25.0	18.1	1.4	1.4

● Material: Bronze (UNS C52100) nickel-plated (3 μm)

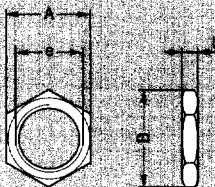
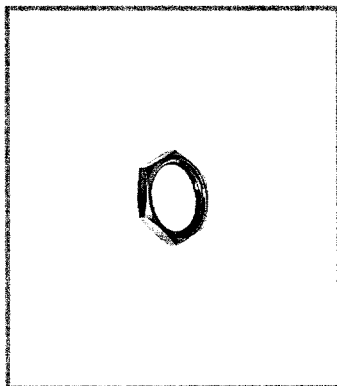

GEA Hexagonal nuts

Series	Dimensions (mm)				Weight (g)
	A	B	e	L	
0F	11	12.5	M9x0.6	2.0	0.7
1F	14	16.0	M12x1.0	2.5	1.3
2F	17	19.5	M15x1.0	2.7	1.9
3F	22	25.2	M18x1.0	3.0	4.2

● Material: Aluminum alloy (AA 6012) natural anodized aluminum alloy.

Tooling

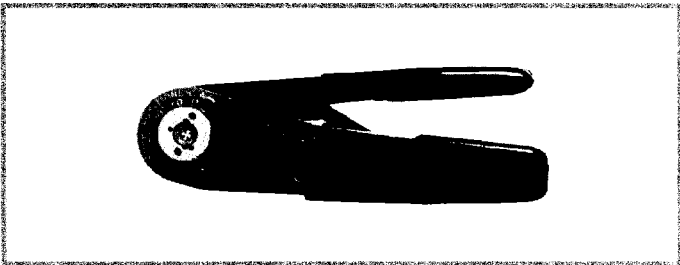

DPC Manual crimping tool



According to specification MIL-C-22520/7-01
For LEMO contacts \varnothing 0.7-0.9-1.3 mm

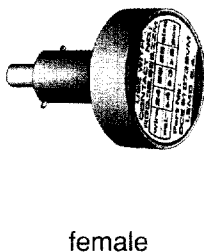
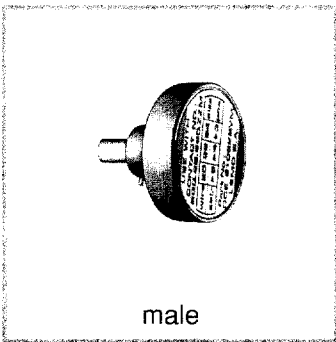

DCE Positioners for crimp contacts

Connector		Positioner part number	
Contact \varnothing	Conductor AWG	For male contact	For female contact
1.3	18-20-22	DCE.91.131.FVC	DCE.91.131.FVM
0.9	20-22-24	DCE.91.090.BVC	DCE.91.090.BVM
0.7	22-24-26	DCE.91.070.BVC	DCE.91.070.BVM

These positioners are suitable for use with both manual and pneumatic crimping tools according to the MIL-C-22520/7-01 standard.

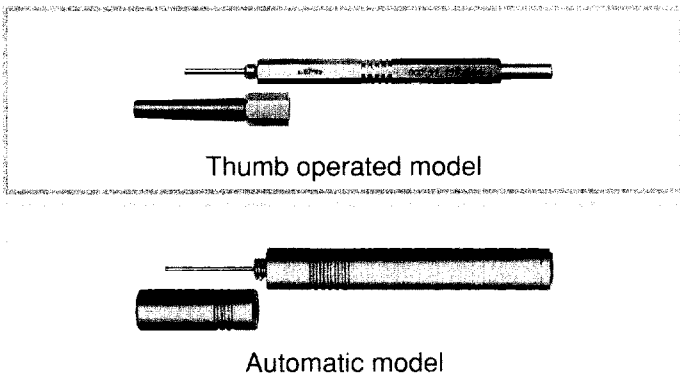

DCC Extraction tools for crimp contacts

Contact \varnothing	Automatic model
1.3	DCF.91.131.2LT
0.9	DCF.91.090.2LT
0.7	DCF.91.070.2LT

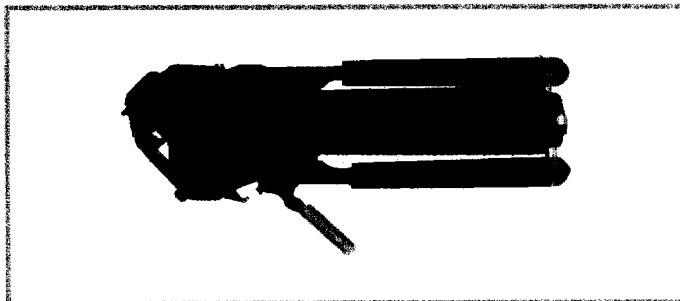

Banding tool

	TIE-DEX®	AXON®
Banding tool	A40199	ACDBS100
Tie wrap	A31166	AXCL0Z

Cut-Out

Panel cut-out (P1 and P2)

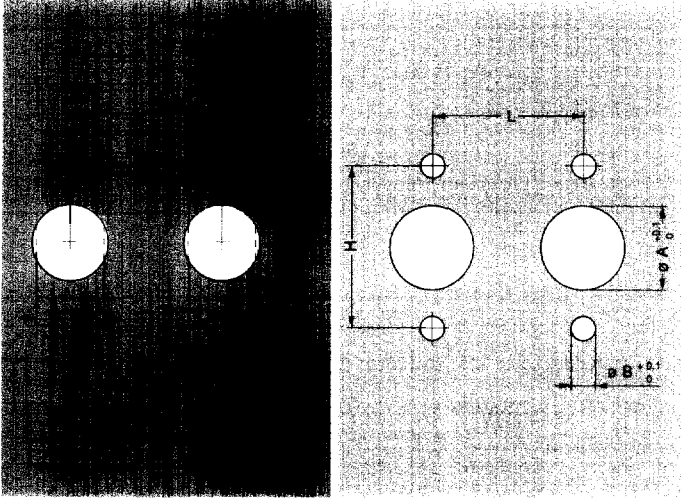

	Models			Series	Dimensions (mm)			
					A	B	L	H
P2	EEN	HEN	PEN	0F	9.1	10.1	16.0	—
	EEN	HEN	PEN	1F	11.6	13.1	20.0	—
	EEN	HEN	PEN	2F	14.6	16.1	23.0	—
	EEN	HEN	PEN	3F	16.6	18.1	25.0	—
	—	HEW	PEW	4F	22.1	24.1	32.0	—
	—	HEW	PEW	5F	31.1	33.1	41.0	—
	—	EGN	—	0F	9.1	8.3	13.5	—
	—	EGN	—	1F	12.1	10.6	17.0	—
	—	EGN	—	2F	15.1	13.6	21.5	—
	—	EGN	—	3F	18.2	16.7	27.0	—
—	EBN	—	0F	11.1	3.2	16.0	21.4	
—	EBN	—	1F	13.1	3.2	16.0	21.4	
—	EBN	—	2F	16.1	3.2	19.0	25.9	
—	EBN	—	3F	18.1	3.2	21.0	32.5	
—	EBW	—	4F	24.1	3.2	27.0	34.8	
—	EBW	—	5F	33.1	3.2	33.5	38.2	

PCB drilling pattern (P3 = HEN)

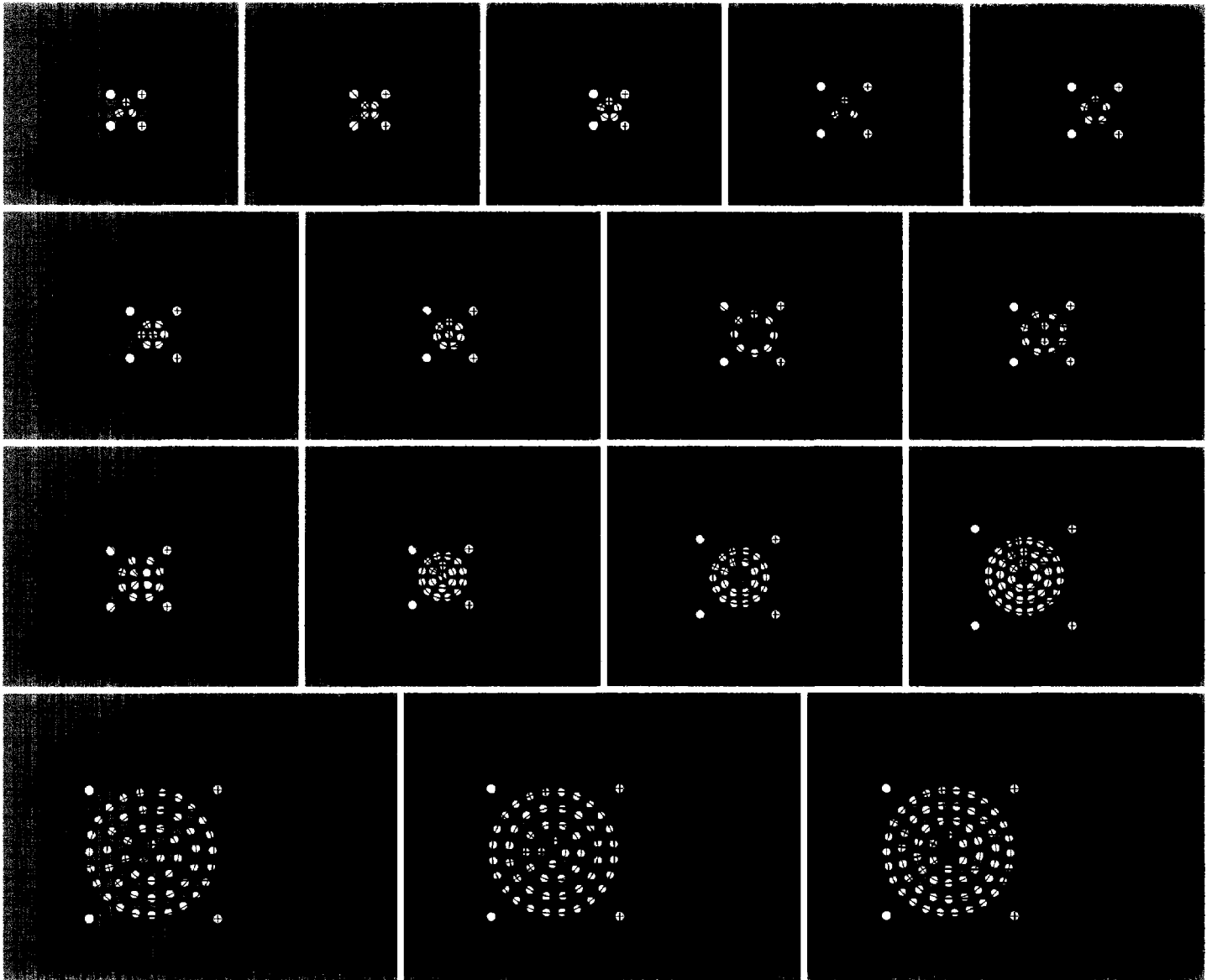

Termination Instructions

Termination of plug and receptacles

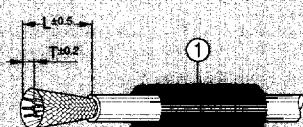
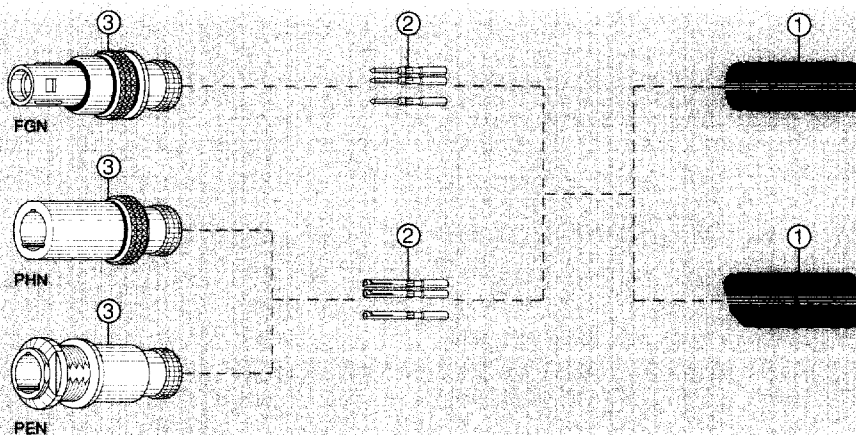

1. Cable preparation

First place the heatshrink boot ① on the cable. Strip the cable according to dimensions of the table, then widen the shield braid.

	T	L
	4	14
	4	14
	4	14
	4	14
	4	14
	4	14

2. Cable termination

2.1 Fix the appropriate positioner in the crimping tool and set the selector to the number corresponding to the conductor AWG as indicated on the positioner label. Fit conductor into contact ② and make sure it is visible through the inspection hole in the crimp barrel. Open crimping tool then push contact fully into positioner and complete one crimping cycle. Remove from crimping tool and check that conductor is secure in contact and shows in inspection hole.

2.2 Slide the assembly into the connector shell ③. Arrange the contacts according to the marking, then push them into the insulator, make sure the contacts are in place by gently pulling on the cable.

2.3 Put the screen all around the latching sleeve. Cut off possible surplus. Use a band-it tie wrap to fix the braid in place (see tooling in page 17).

2.4 Put the heatshrink boot in place and heat gently until it retracts.

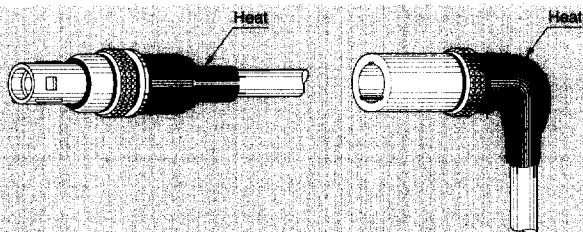
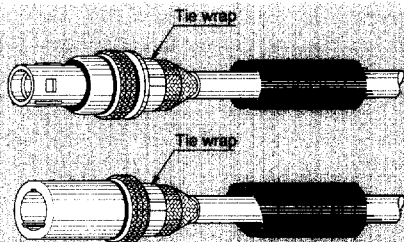
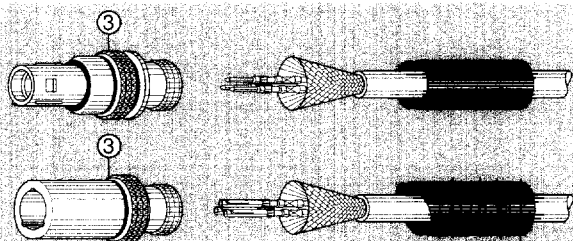
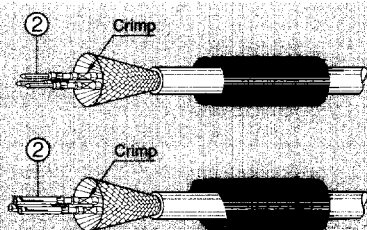

THE QUALITY CHOICE

LEMO USA Inc.

335 Tesconi Circle Santa Rosa CA 95406
Tel: 1-707-578 8811 1-800-444 LEMO Fax: 1-707-578 0869
email: lemousa@aol.com