

MS5 SERIES

85°C 5mm Height.

◆FEATURES

- RoHS compliance.

MS5

105°C Version

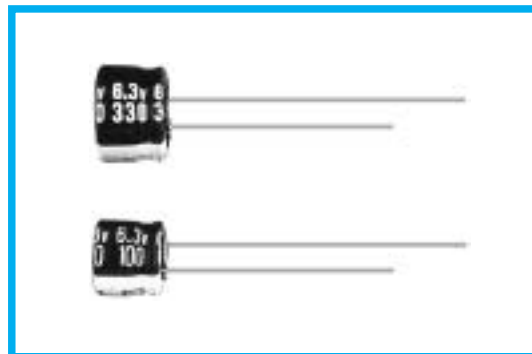
MH5

◆規格表 SPECIFICATIONS

Items	Characteristics																								
Category Temperature Range	-40~+85°C																								
Rated Voltage Range	4~50V.DC																								
Capacitance Tolerance	±20% (20°C, 120Hz)																								
Leakage Current(MAX) (tan δ)	I=0.01CV or 3 μA whichever is greater. (After 2 minutes application of rated voltage) I=Leakage Current(μA) C=Rated Capacitance(μF) V=Rated Voltage(V)																								
Dissipation Factor(MAX)	<table border="1"> <thead> <tr> <th>Rated Voltage (V)</th> <th>4</th> <th>6.3</th> <th>10</th> <th>16</th> <th>25</th> <th>35</th> <th>50</th> </tr> </thead> <tbody> <tr> <td>tan δ</td> <td>0.35</td> <td>0.26</td> <td>0.22</td> <td>0.18</td> <td>0.16</td> <td>0.14</td> <td>0.12</td> </tr> </tbody> </table> (20°C, 120Hz)	Rated Voltage (V)	4	6.3	10	16	25	35	50	tan δ	0.35	0.26	0.22	0.18	0.16	0.14	0.12								
Rated Voltage (V)	4	6.3	10	16	25	35	50																		
tan δ	0.35	0.26	0.22	0.18	0.16	0.14	0.12																		
Endurance	After applying rated voltage with rated ripple current for 1000 hrs at 85°C, the capacitors shall meet the following requirements. <table border="1"> <tbody> <tr> <td>Capacitance Change</td> <td>Within ±25% of the initial value.</td> </tr> <tr> <td>Dissipation Factor</td> <td>Not more than 200% of the specified value.</td> </tr> <tr> <td>Leakage Current</td> <td>Not more than the specified value.</td> </tr> </tbody> </table>	Capacitance Change	Within ±25% of the initial value.	Dissipation Factor	Not more than 200% of the specified value.	Leakage Current	Not more than the specified value.																		
Capacitance Change	Within ±25% of the initial value.																								
Dissipation Factor	Not more than 200% of the specified value.																								
Leakage Current	Not more than the specified value.																								
Low Temperature Stability mpedance Ratio(MAX)	<table border="1"> <thead> <tr> <th>Rated Voltage (V)</th> <th>4</th> <th>6.3</th> <th>10</th> <th>16</th> <th>25</th> <th>35</th> <th>50</th> </tr> </thead> <tbody> <tr> <td>Z(-25°C)/Z(20°C)</td> <td>7</td> <td>6</td> <td>4</td> <td>4</td> <td>3</td> <td>2</td> <td>2</td> </tr> <tr> <td>Z(-40°C)/Z(20°C)</td> <td>15</td> <td>12</td> <td>10</td> <td>8</td> <td>6</td> <td>4</td> <td>4</td> </tr> </tbody> </table> (120Hz)	Rated Voltage (V)	4	6.3	10	16	25	35	50	Z(-25°C)/Z(20°C)	7	6	4	4	3	2	2	Z(-40°C)/Z(20°C)	15	12	10	8	6	4	4
Rated Voltage (V)	4	6.3	10	16	25	35	50																		
Z(-25°C)/Z(20°C)	7	6	4	4	3	2	2																		
Z(-40°C)/Z(20°C)	15	12	10	8	6	4	4																		

◆MULTIPLIER FOR RIPPLE CURRENT

Frequency coefficient

Frequency (Hz)	60(50)	120	500	1k	10k≤
0.1~1 μF	0.50	1.0	1.20	1.30	1.50
1.5~6.8 μF	0.65	1.0	1.20	1.30	1.50
10~68 μF	0.8	1.0	1.20	1.30	1.50
100~470 μF	0.8	1.0	1.10	1.15	1.20

◆PART NUMBER

□□□	MS5	□□□□□	□	□□□	□□	D×L
Rated Voltage	Series	Rated Capacitance	Capacitance Tolerance	Option	Lead Forming	Case Size

◆ DIMENSIONS

(mm)

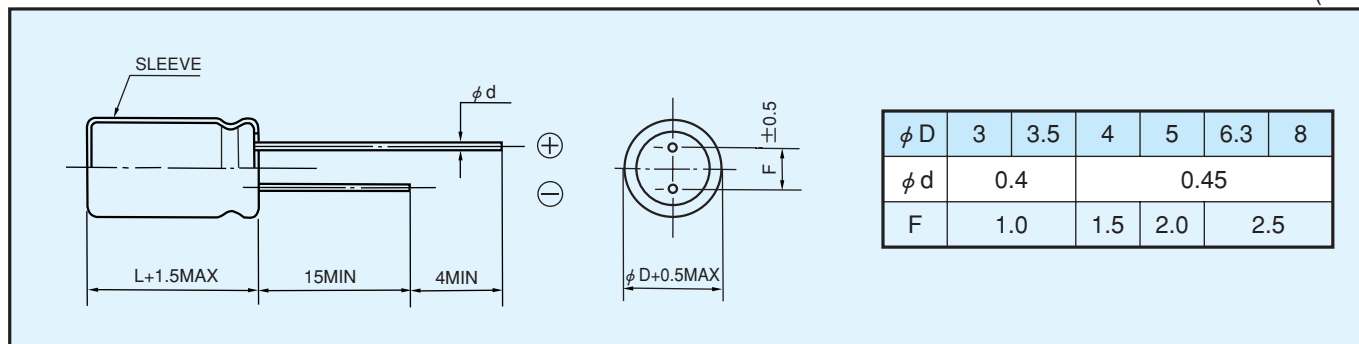
◆ STANDARD SIZE, RATED RIPPLE CURRENT

 Size $\phi D \times L$ (mm), Ripple Current (mA r.m.s./85°C, 120Hz)

WV (V.DC) Cap (μF)	4 (0G)		6.3 (0J)		10 (1A)		16 (1C)	
	Size	Ripple	Size	Ripple	Size	Ripple	Size	Ripple
4.7							● 4×5	11
6.8					● 4×5	10	* 4×5	13
10			● 4×5	14	● 4×5	16	* 4×5	18
15			* 4×5	18	4×5	22	5×5	26
22	● 4×5	20	4×5	22	5×5	30	5×5	35
33	* 4×5	27	5×5	34	5×5	45	6.3×5	51
47	4×5	37	5×5	37	6.3×5	50	6.3×5	65
68	5×5	45	6.3×5	55	6.3×5	59	6.3×5	70
100	5×5	62	6.3×5	62	6.3×5	80	8×5	92
220	6.3×5	74	8×5	120	8×5	145		
330	8×5	145	8×5	145				
470	8×5	181						

WV (V.DC) Cap (μF)	25 (1E)		35 (1V)		50 (1H)	
	Size	Ripple	Size	Ripple	Size	Ripple
0.1					● 4×5	1
0.15					● 4×5	1.5
0.22					● 4×5	2.5
0.33					● 4×5	4
0.47					● 4×5	6
0.68					● 4×5	7
1					● 4×5	8.6
1.5					● 4×5	8.7
2.2			● 4×5	9	* 4×5	9.1
3.3	● 4×5	11	* 4×5	12	4×5	13
4.7	* 4×5	13	4×5	14	5×5	20
6.8	4×5	19	5×5	20	6.3×5	26
10	5×5	27	5×5	27	6.3×5	31
15	5×5	33	6.3×5	35	6.3×5	39
22	6.3×5	46	6.3×5	46	8×5	60
33	6.3×5	54	8×5	65	8×5	80
47	6.3×5	65	8×5	85		
68	8×5	90				
100	8×5	120				

3mm DIA. is available for marked ●, and 3.5mm DIA. is available for marked * when specified.