

Low Capacitance Surface Mount TVS Diodes

FEATURES

- Four ultra-low input capacitance (1 pF typ.) ESD rail-to-rail protection diodes
- ESD IEC 61000-4-2 level 4, ± 8kV contact Discharge compliant protection
- Low voltage clamping due to integrated Zener diode
- Compact SOT-23-6 package

APPLICATION

General-purpose downstream ESD protection high frequency analog signals and high-speed serial data transmission for ports inside:

- PC-/Notebook USB2.0/IEEE1394 ports
- Cellular phone and PCS mobile handsets
- DVI interfaces
- Cordless telephones
- Wireless data (WAN/LAN) systems
- PDAs

The **L054BT26** devices are low-capacitance transient voltage suppressors designed to protect components which are connected to data and transmission lines from over voltages caused by electrostatic discharge (ESD), electrical fast transients (EFT), and induced lightning.

SCHEMATIC & PINNING (SOT23-6)

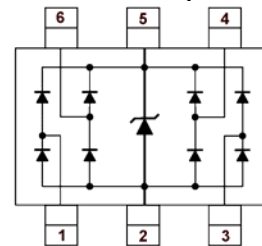

CIRCUIT DIAGRAM

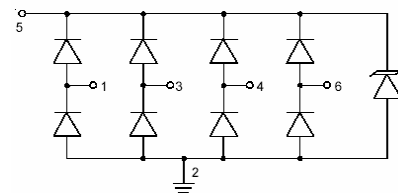

MAXIMUM RATINGS

RATING	SYMBOL	MIN	MAX	UNIT
DC input voltage range	$V_{I/O}$	0	+5.5	Volts
Electrostatic Discharge, all pins (IEC 61000-4-2, Level 4, Contact)	ESD	-8	+8	KiloVolts
Device Storage Temperature	T_{stg}	-55	+125	°C

ELECTRICAL CHARACTERISTICS $T_C = 25^\circ\text{C}$ unless otherwise specified

PARAMETER	TEST CONDITIONS	SYMBOL	MIN	TYP	MAX	UNIT
Pin capacitance to ground, Pins 1, 3, 4, 6	$V_{dc} = 0V$; $f = 1\text{ MHz}$ Pin 5 = +3.0V	$C_{I/O}$	-	1.0	-	pF
Diode reverse leakage current, Pins 1, 3, 4, 6 to ground	$V = +3.0V$	I_{lkg}	-	-	100	nA
Zener diode capacitance to ground, Pin 5 to 2	$V_{dc} = 0V$; $f = 1\text{ MHz}$ Pin 5 = +3.0V	C_{Zener}	-	40	-	pF
Zener diode breakdown voltage, Pin 5 to 2	$I = 1\text{ mA}$	$V_{BR\ I/O}$	6	-	9	V
Forward voltage		V_F	-	0.7	-	V

August 2007 / Rev.5

Non-Repetitive Peak Pulse Power vs. Pulse Time

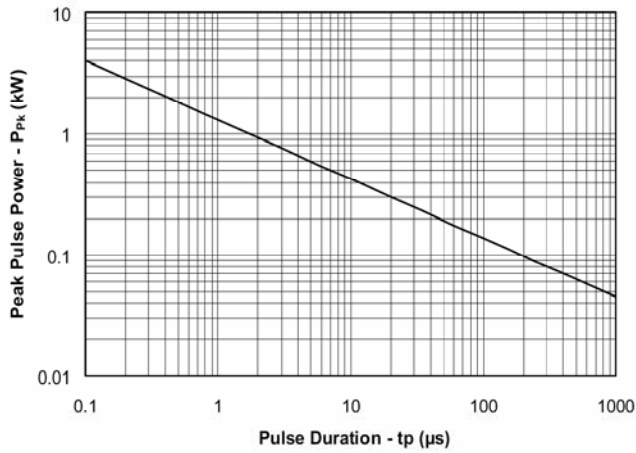

Power Derating Curve

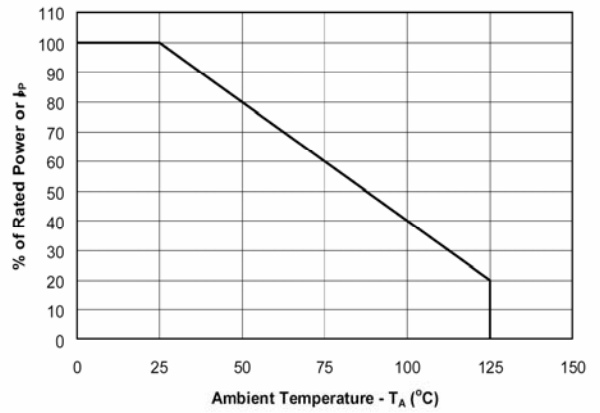

Pulse Waveform

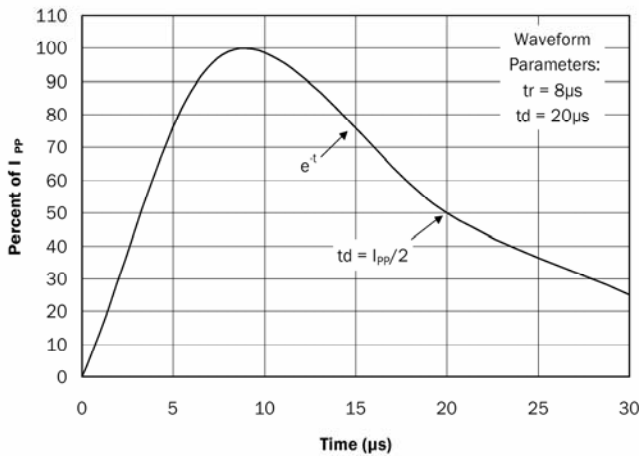

Clamping Voltage vs. Peak Pulse Current

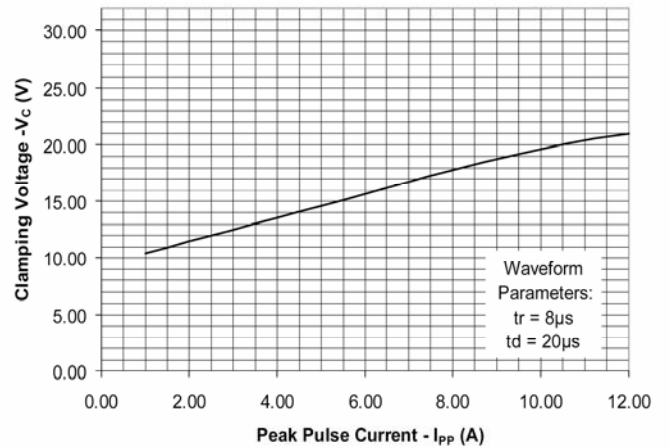

Forward Voltage vs. Forward Current

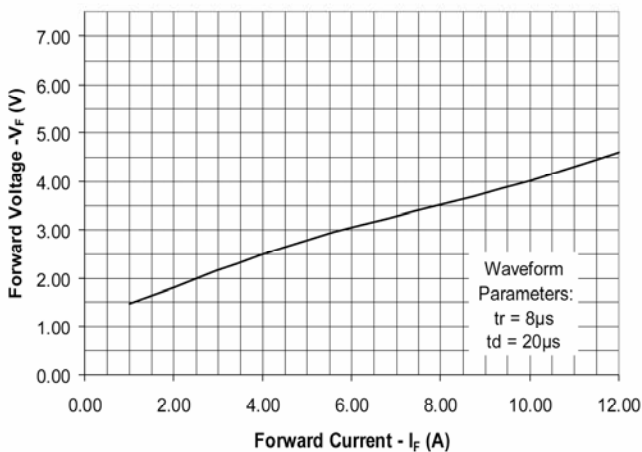

Capacitance vs. Reverse Voltage

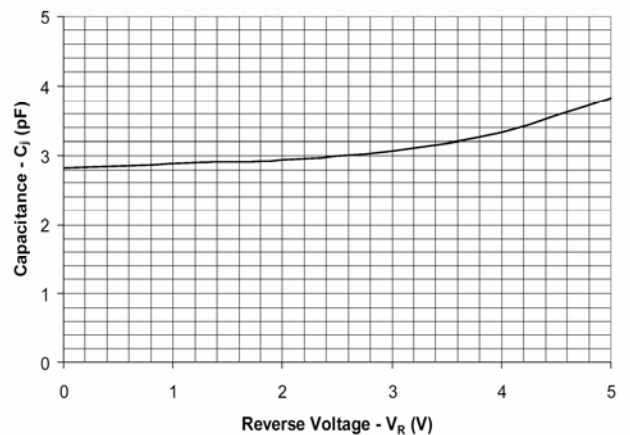

APPLICATION INFORMATION

1.0 Four High-Speed Data Lines Protection

The **L054BT26** TVS diode is designed to protect up to four data lines from transient over-voltages by clamping them to a fixed reference. When the voltage on the protected line(s) exceeds the reference voltage (plus diode V_F), the steering diodes are forward biased, conducting the transient current away from the protected circuitry. The data lines are connected to pins 1, 2, 4 and 6. The negative reference (REF1) is connected to pin 2 (*This pin should be connected directly to the ground plane on the PCB for best results*). The path length is kept as short as possible to minimize parasitic inductance. The positive reference (REF2) is connected to pin 5.

The typical options for connecting the positive reference are as follows:

A. DATA LINE AND POWER SUPPLY PROTECTION USING V_{CC} AS REFERENCE

To protected data lines and the power line, connect pin 5 directly to the positive supply rail (V_{CC}). In this configuration, the data lines are referenced to the supply voltage. The internal TVS diode prevents over-voltage on the supply rail.

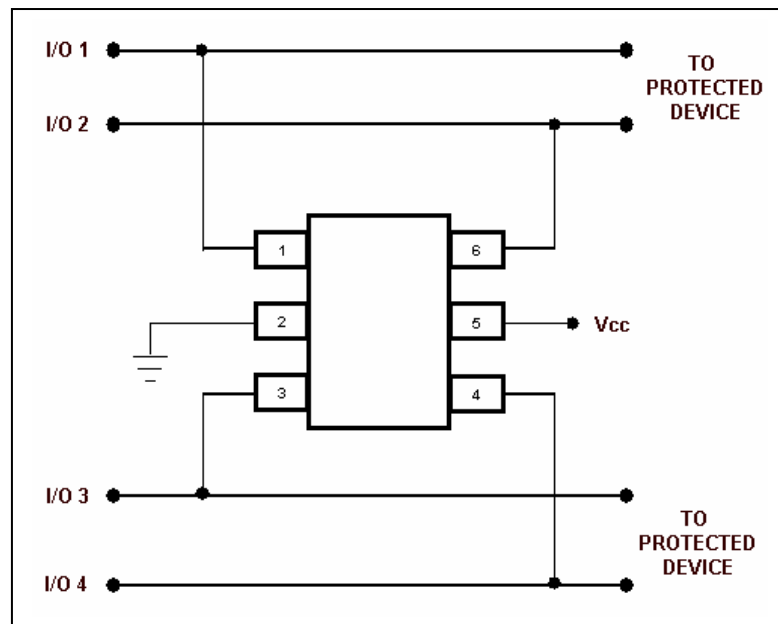

APPLICATION INFORMATION (continued)

B. DATA LINE PROTECTION WITH BIAS AND POWER SUPPLY ISOLATION RESISTOR

The **L054BT26** can be isolated from the power supply by adding a series resistor between pin 5 and V_{CC} (A resistor value of $100k\Omega$ is recommended). The internal TVS and steering diodes remain biased, providing the advantage of even lower capacitance.

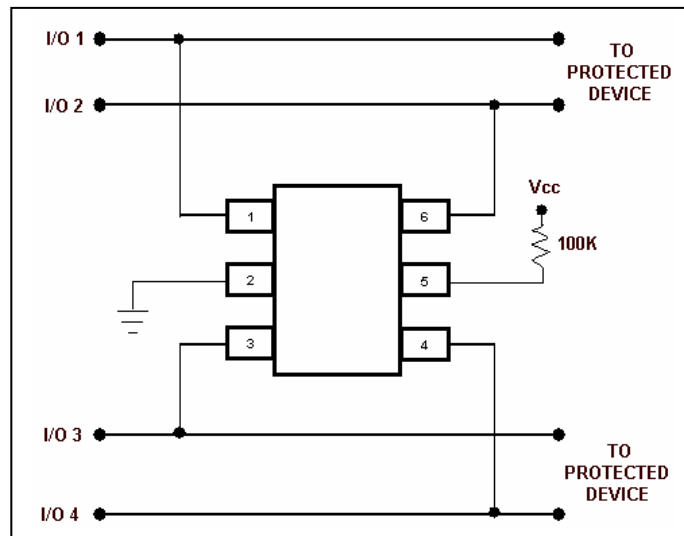

C. DATA LINE PROTECTION USING INTERNAL TVS DIODE AS REFERENCE

In applications where no positive supply reference is available, or complete supply isolation is desired, the internal TVS may be used as the reference. In this case, pin 5 is not used. The steering diodes will begin to conduct when the voltage on the protected line exceeds the working voltage of the TVS (plus one diode drop).

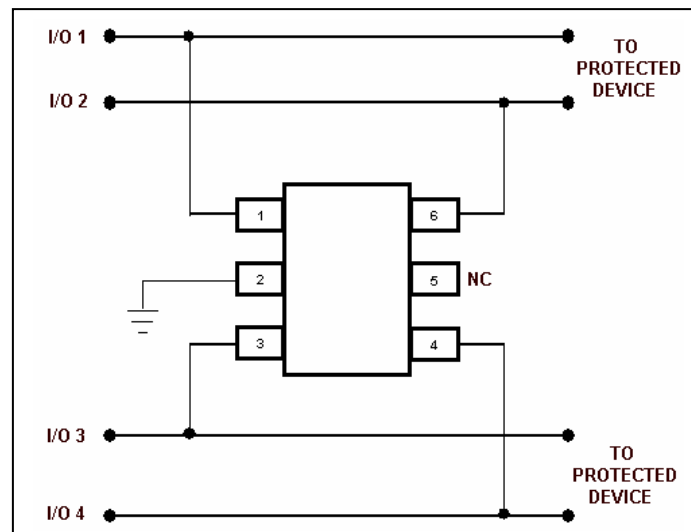

APPLICATION INFORMATION (*continued*)**2.0 Universal Serial Bus (USB) ESD Protection**

The **L054BT26** can be used to protect the USB ports on mobile phones, monitors, PCs, peripherals and other portable systems (*please refer to schematic diagram below*). In typical applications, the voltage bus (V_{BUS}) of USB ports are connected to the power pin (pin 5) of the device. Each data line (D+/D-) of the USB ports is connected to the ESD protection pin of the device.

When an electrostatic discharge (ESD) pulse appears on the data line, the ESD pulse current will be conducted by the **L054BT26** away from the USB controller chip. In addition, the ESD pulse current can also be conducted by the device away from the USB controller chip when the ESD voltage pulse appears on the voltage bus (V_{BUS}) of any of the USB ports. Therefore, the data lines (D+/D-) and voltage bus (V_{BUS}) of the two USB ports are complementally protected with the **L054BT26** device.

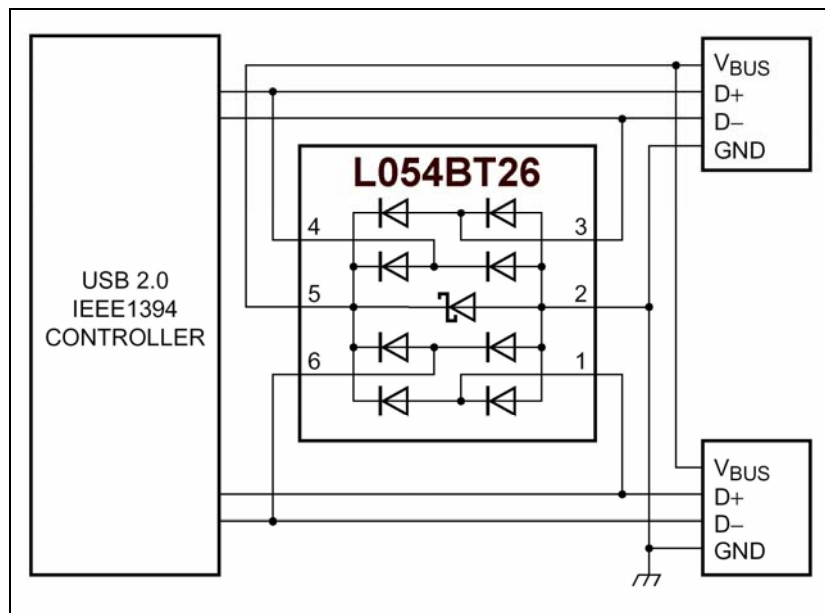

Typical Universal Serial Bus 2.0 Serial Application of the L054BT26

APPLICATION INFORMATION *(continued)*

3.0 Audio interface ESD Protection

Another typical application of the **L054BT26** is ESD protection of the Right/Left channel and TMC terminals of an audio interface. Referring to the schematic diagram below, the Right and Left channels of the audio connector are connected to the ESD protection pins (such as pin 1 and pin 6) of the **L054BT26**. In addition, the TMC terminals of the audio connector are also connected to the ESD protection pins (such as pin 3 and pin 4) of the device. Regarding the power pin (pin 5) of the device, this should be directly connected to the V_{DD} power supply.

In this configuration, when an electrostatic discharge (ESD) voltage pulse appears on the Right or Left channel or TMC terminals of audio connector, the ESD pulse current will automatically be discharged by the **L054BT26**. Therefore, the Right/Left channel and TMC terminals of the audio chip are complementally protected with an **L054BT26** device.

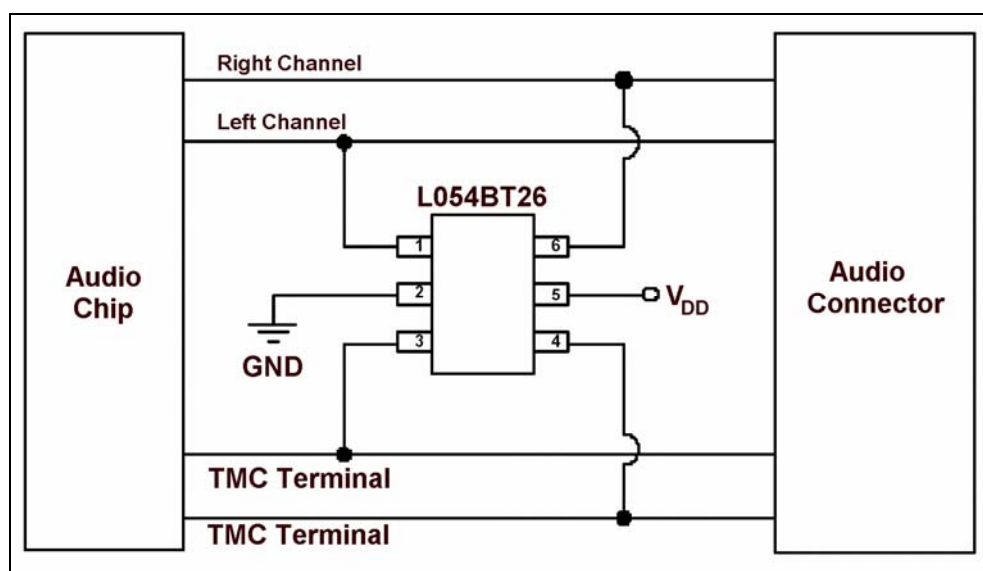

Typical Audio Interface Application of the L054BT26

APPLICATION INFORMATION (continued)

4.0 Other Applications

DVI/HDMI Digital Single Link ESD Protection

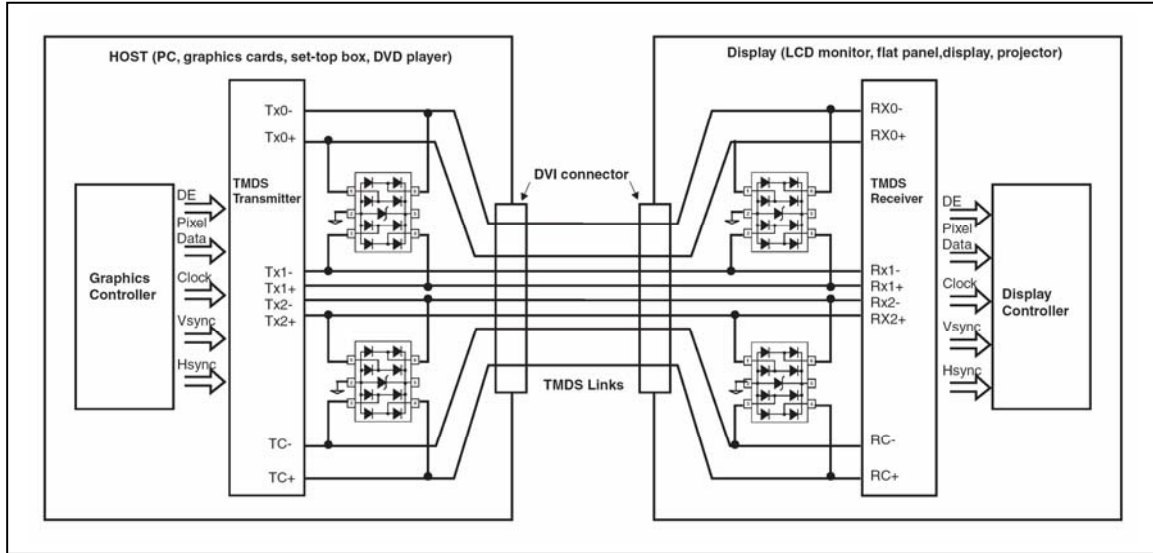

T1/E1/Ethernet ESD Protection

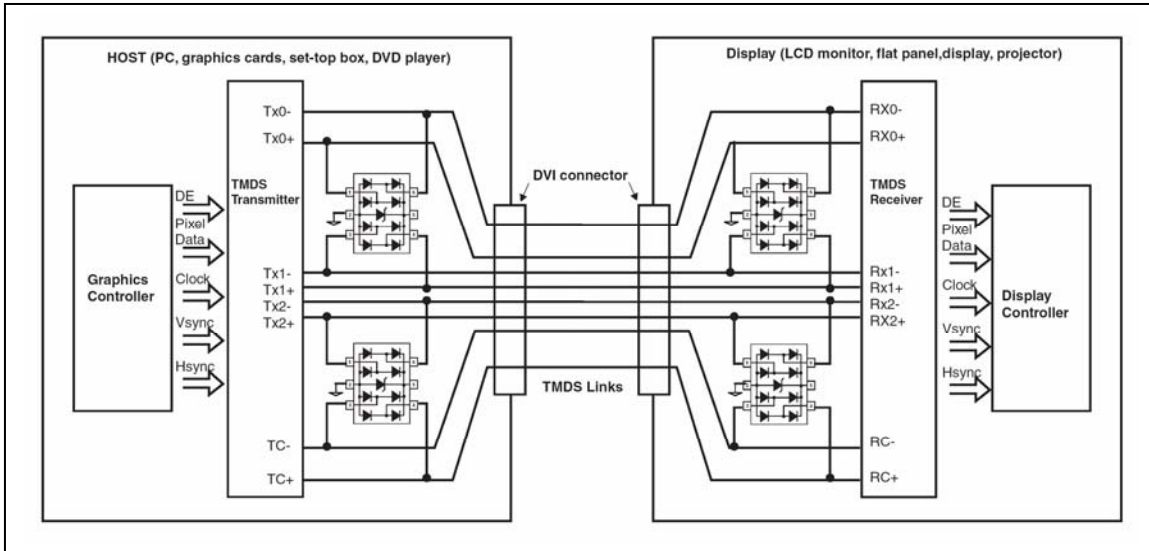

PACKAGE DRAWING

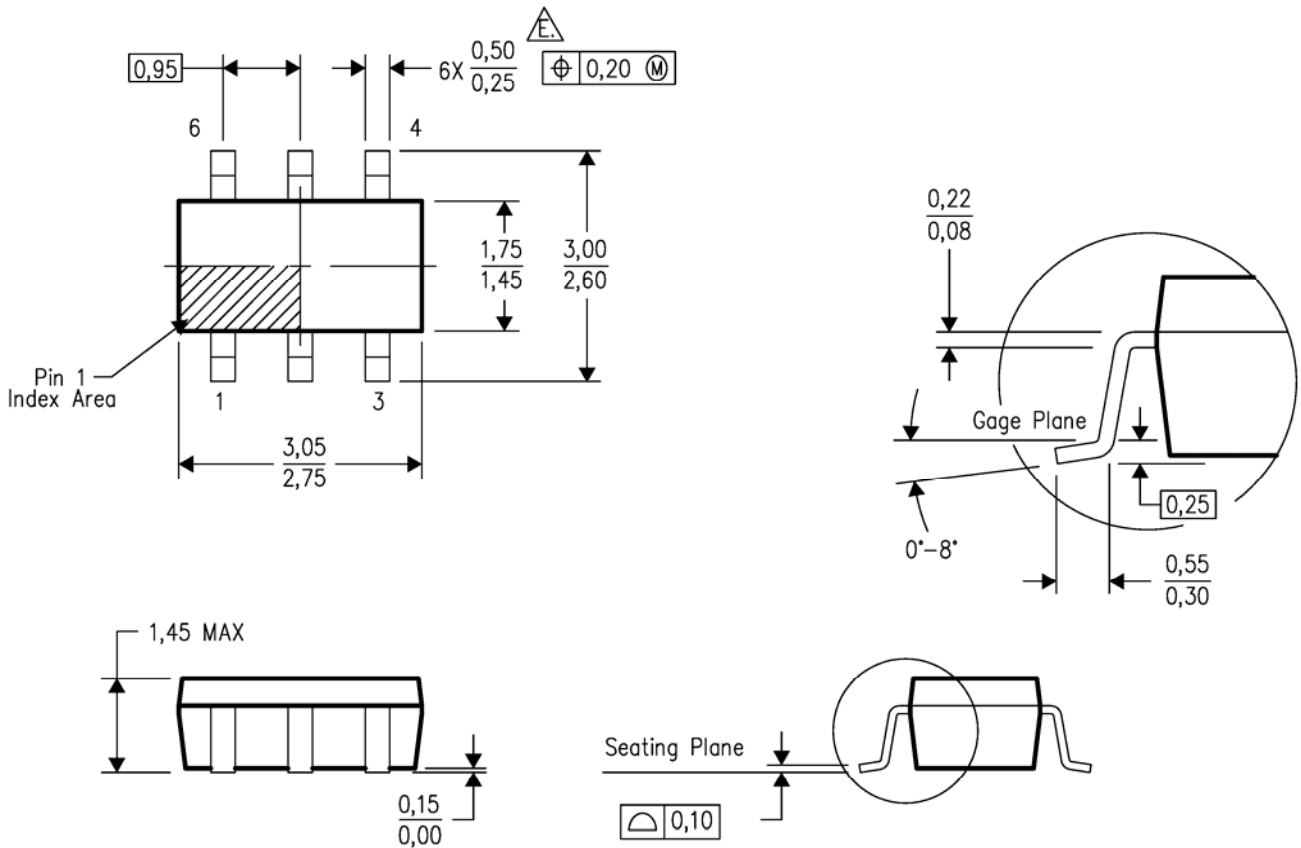

MARKING CODES



Part Number	Marking Code
L054BT26	5V4