

NOTES:

1. MATERIAL: SEE TABLE
2. FINISHES: SEE TABLE
3. PRODUCT SPECIFICATION: NOT REQUIRED
4. PACKAGING: NOT REQUIRED
5. MATES WITH: 5.08mm (.200in) BEAU EUROSTYLE HEADERS (39860 SERIES OR BEAU SERIES 86 HEADERS)
6. "XX" REFERS TO THE QUANTITY OF CIRCUITS.
7. SEE SHEET 2 FOR LENGTH TABLE AND CIRCUIT IMPRINTING OPTIONS.

39860-0102
ONE LATCH DETAIL
POSITIONED ON THIS END.

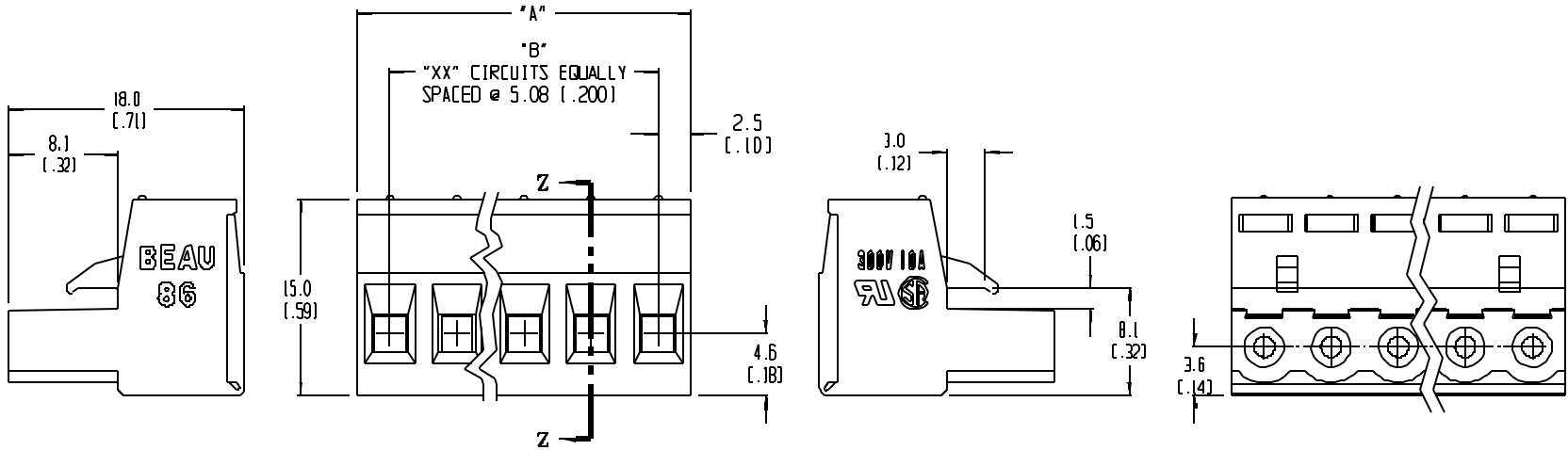
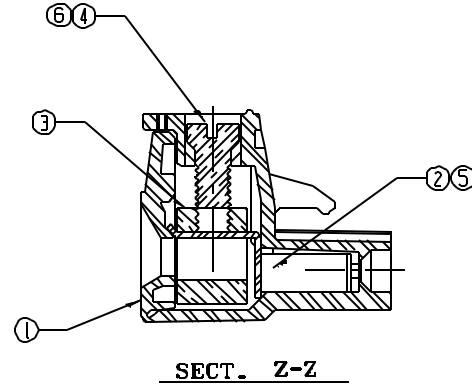
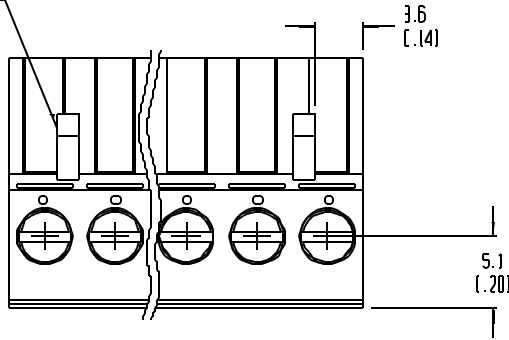

ITEM	QTY.	DESCRIPTION	MATERIAL	FINISH
6	"XX"	SCREW, M3 X 0.5 (-G30 OPT.)	PHOSPHOR BRONZE	TIN PLATE
5	"XX"	TERMINAL (-G30 OPTION)	PHOSPHOR BRONZE	GOLD PLATE
4	"XX"	SCREW, M3 X 0.5	STEEL	ZN, CLEAR CHROMATE
3	"XX"	CAGE CLAMP	BRASS	NICKEL
2	"XX"	TERMINAL	PHOSPHOR BRONZE	HOT TIN DIP
1	1	INSULATOR	THERMO-PLASTIC	BLACK/GREEN

ECN NO. ECN 3884	DRWN: JF 10-21-04
CHK: []	APPR: []
REV	DESCRIPTION

QUALITY SYMBOLS	
MAJOR	=
CRITICAL	=
SPE	=

GENERAL TOLERANCES: (UNLESS SPECIFIED)	
4 PLACES	±.0015
3 PLACES	±.008 ±.005
2 PLACES	±.13 ±.01
1 PLACE	±.3
ANGULAR: ±2°	
DRAFT WHERE APPLICABLE MUST REMAIN WITHIN DIMENSIONS	

SCALE: 3:1	DESIGN UNITS: <input type="checkbox"/> mm <input checked="" type="checkbox"/> INCH
DRAWN BY & DATE: R. KEMP 12-6-01	CHECKED BY & DATE: P. VALTZ 12-6-01
APPROVED BY & DATE: L. ROTHALUS 12-6-01	CAD FILENAME: 8685XX

PROJECT NO. N/A	SHT	REV
DIMENSIONS: <input checked="" type="checkbox"/> mm <input type="checkbox"/> INCH <input type="checkbox"/> mm ONLY	REVISE ON CAD ONLY	
THIRD ANGLE PROJECTION		
TITLE: PLUGGABLE SR B1S ASSY, (.200 CENTERS) WITH KEY FEATURE		
MOLEX INCORPORATED		
MATERIAL NO. SEE SHT. 2	DRAWING NO. SD-39860-001	SHEET NO. 1 OF 2
THIS DRAWING CONTAINS INFORMATION THAT IS PROPRIETARY TO MOLEX (INCORPORATED AND SHOULD NOT BE USED WITHOUT WRITTEN PERMISSION.		SIZE B

NUMBER OF CIRCUITS "XX"	DIM "A"	DIM "B"	MATERIAL NO. (GREEN)	MATERIAL NO. (STD.)	MATERIAL NO. (-G30 OPTION)	MATERIAL NO. (-10A OPTION)	MATERIAL NO. (-11A OPTION)	MATERIAL NO. BITS	MATERIAL NO. GREEN BITS	ENG. NO. BITS	ENG. NO. GREEN BITS
02	.400	.200	39860-3102	39860-D102	39861-0102	39862-0102	39863-0102	39868-1201	39868-3202	8683-0201-1000	8683-0203-1000
03	.600	.400	39860-3103	39860-D103	39861-0103	39862-0103		39868-1203	39868-3203	8683-0301-1000	8683-0303-1000
04	.800	.600	39860-3104	39860-D104	39861-0104	39862-0104	39863-0104	39868-1204	39868-3204	8683-0401-1000	8683-0403-1000
05	1.000	.800	39860-3105	39860-D105	39861-0105	39862-0105		39868-1205	39868-3205	8683-0501-1000	8683-0503-1000
06	1.200	1.000	39860-3106	39860-D106	39861-0106	39862-0106		39868-1206	39868-3206	8683-0601-1000	8683-0603-1000
07	1.400	1.200	39860-3107	39860-D107	39861-0107	39862-0107		39868-1207	39868-3207	8683-0701-1000	8683-0703-1000
08	1.600	1.400	39860-3108	39860-D108	39861-0108	39862-0108	39863-0108	39868-1208	39868-3208	8683-0801-1000	8683-0803-1000
09	1.800	1.600	39860-3109	39860-D109	39861-0109		39863-0109	39868-1209	39868-3209	8683-0901-1000	8683-0903-1000
10	2.000	1.800	39860-3110	39860-D110	39861-0110	39862-0110		39868-1210	39868-3210	8683-1001-1000	8683-1003-1000
11	2.200	2.000	39860-3111	39860-D111	39861-0111			39868-1211	39868-3211	8683-1101-1000	8683-1103-1000
12	2.400	2.200	39860-3112	39860-D112	39861-0112	39862-0112	39863-0112	39868-1212	39868-3212	8683-1201-1000	8683-1203-1000
13	2.600	2.400	39860-3113	39860-D113	39861-0113	39862-0113		39868-1213	39868-3213	8683-1301-1000	8683-1303-1000
14	2.800	2.600	39860-3114	39860-D114	39861-0114	39862-0114	39863-0114	39868-1214	39868-3214	8683-1401-1000	8683-1403-1000
15	3.000	2.800	39860-3115	39860-D115	39861-0115	39862-0115		39868-1215	39868-3215	8683-1501-1000	8683-1503-1000
16	3.200	3.000	39860-3116	39860-D116	39861-0116	39862-0116		39868-1216	39868-3216	8683-1601-1000	8683-1603-1000

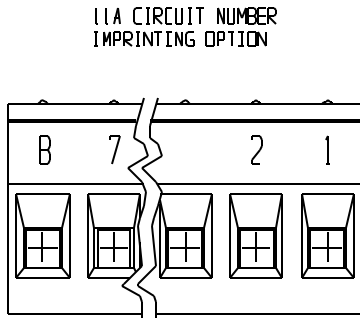
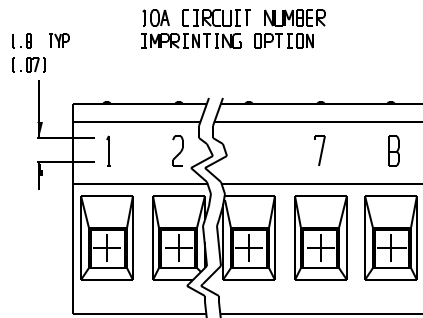

EC. NO. SEE SHEET 1 DRWN: R. KEMP CHK: P. WALTZ APPR: L. ROTHALUS	QUALITY SYMBOLS MAJOR = CRITICAL = SPEC = REV =	GENERAL TOLERANCES (UNLESS SPECIFIED) 4 PLACES ±.038 ±.0015 3 PLACES ±.038 ±.005 2 PLACES ±.13 ±.01 1 PLACE ±.3 ANGULAR: ±2° DRAFT WHERE APPLICABLE MUST REMAIN WITHIN DIMENSIONS	SCALE 3:1 DESIGN UNITS <input type="checkbox"/> mm <input checked="" type="checkbox"/> INCH	DRAWN BY & DATE R. KEMP 12-6-01 CHECKED BY & DATE P. WALTZ 12-6-01 APPROVED BY & DATE L. ROTHALUS 12-6-01	PROJECT NO. N/A DIMENSIONS: <input checked="" type="checkbox"/> mm <input type="checkbox"/> INCH <input type="checkbox"/> mm <input type="checkbox"/> INCH ONLY THIRD ANGLE PROJECTION	SHEET REV 2 OF 2
			TITLE: PLUGGABLE SR BITS ASSY, (.200 CENTERS) WITH KEY FEATURE	MOLEX INCORPORATED	MATERIAL NO. SEE CHART DRAWING NO. SD-39860-001	SHEET NO. 2 OF 2 SIZE B

THIS DRAWING CONTAINS INFORMATION THAT IS PROPRIETARY TO MOLEX INCORPORATED AND SHOULD NOT BE USED WITHOUT WRITTEN PERMISSION.