

Customer Information Sheet

DRAWING No.: D01-997XX42

SHEET 2 OF 2

IF IN DOUBT - ASK

©

NOT TO SCALE

THIRD ANGLE PROJECTION

ALL DIMENSIONS IN mm

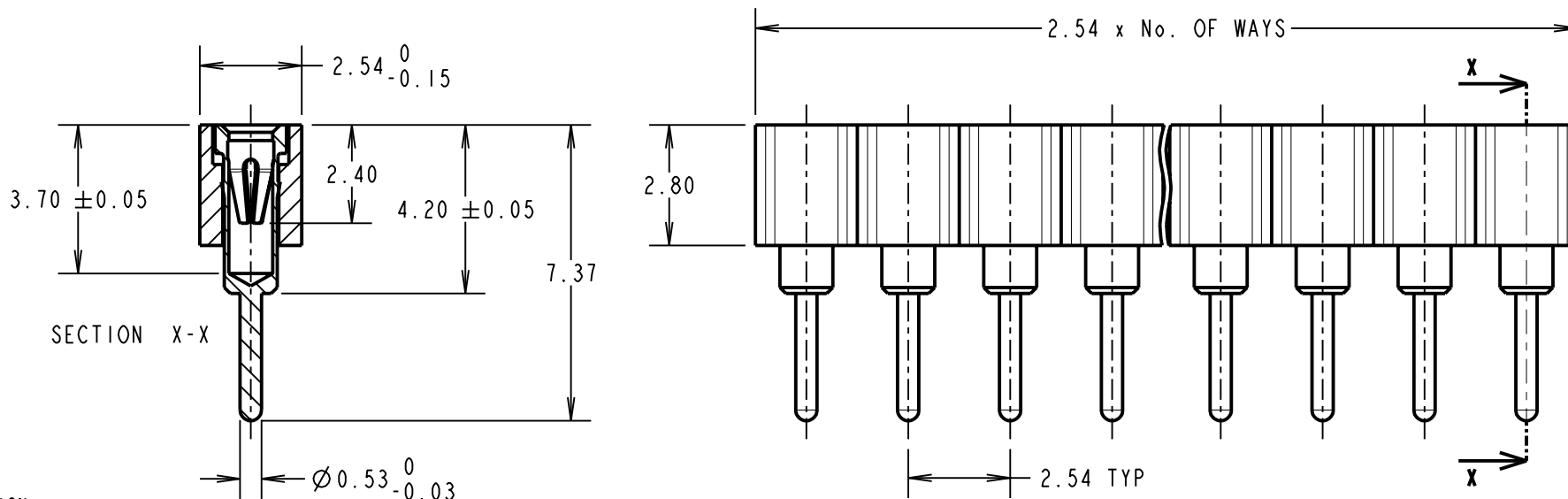

SPECIFICATION:

MATERIAL:

CARRIER = GLASS FILLED PCT, BLACK, UL94V-0
 SHELL = BRASS
 CONTACT = BERYLLIUM COPPER

FINISH:

SHELL = 100% TIN
 CLIP = GOLD

ELECTRICAL:

CURRENT RATING = 1A
 VOLTAGE RATING = 100V AC, 150V DC
 CONTACT RESISTANCE = 10 MILLIOHMS MAX
 INSULATION RESISTANCE = 10000 MEGOHMS MIN
 DIELECTRIC WITHSTANDING = 100V AC MIN.

MECHANICAL:

INSERTION FORCE (Ø0.46mm GAUGE) = 5N MAX
 WITHDRAWAL FORCE (Ø0.46mm GAUGE) = 0.5N MIN
 DURABILITY = 500 CYCLES MIN.

ENVIRONMENTAL:

TEMPERATURE RANGE = +55°C TO +125°C

NOTES:

1. RECOMMENDED PCB SIZE = 1.4-2.0mm
2. RECOMMENDED PIN SIZE = Ø0.40-0.56mm
3. RECOMMENDED PCB HOLE SIZE = Ø0.8mm

ORDER CODE:

D01-997XX42

No. OF WAYS _____
 01-32, 48, 64

FINISH _____
 GOLD CLIP, 100% TIN SHELL

CP	9	14.01.10	10640
NAME	ISS.	DATE	C/NOTE
APPROVED: C.PENROSE			
CHECKED: R.ADDE			
DRAWN: D.BECK			
CUSTOMER REF.:			
ASSEMBLY DRG:			

HARWIN

HARWIN USA
 TEL: 603 893 5376
 FAX: 603 893 5396
 mis@harwin.com

HARWIN Europe (UK)
 TEL: 023 9231 4545
 FAX: 023 9231 4590
 mis@harwin.co.uk

HARWIN Asia
 TEL: +65 6 779 4909
 FAX: +65 6 779 3868
 mis@harwin.com.sg

THIS DRAWING AND ANY INFORMATION OR DESCRIPTIVE MATTER SET OUT HEREON ARE CONFIDENTIAL AND COPYRIGHT PROPERTY OF THE HARWIN GROUP AND MUST NOT BE DISCLOSED, LOANED, COPIED OR USED FOR MANUFACTURING, TENDERING OR FOR ANY OTHER PURPOSE WITHOUT THEIR WRITTEN PERMISSION.

TOLERANCES

X. = ±1mm
 X.X = ±0.25mm
 X.XX = ±0.10mm
 X.XXX = ±0.01mm

ANGLES = ±5°
 UNLESS STATED

MATERIAL:

SEE ABOVE

FINISH: SEE ABOVE

S/AREA: mm²

TITLE:

SIL THROUGH SOCKET CONNECTOR

DRAWING NUMBER:

D01-997XX42

SHT
 2 OF 2