



Standard Linear Products

DC/DC switching regulators, low-voltage LDOs, mid-voltage LDOs and voltage references

NXP
STANDARD
LINEAR



The Standard Linear Portfolio

Low-voltage

NXP's standard linear portfolio for low-voltage applications

- ▶ Low-voltage LDOs
- ▶ High frequency DC/DC solutions

Optimized for applications with challenging space requirements, high battery lifetime demands, and a superior operating stability.

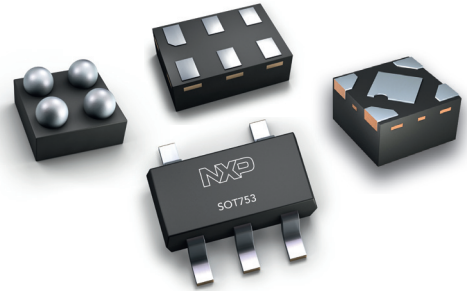

Mid-voltage

NXP's standard linear portfolio for mid-voltage applications

- ▶ Adjustable precision shunt regulators
- ▶ Mid-voltage LDOs with adjustable and fixed output voltages

To support your expectation for high product quality and supply reliability .

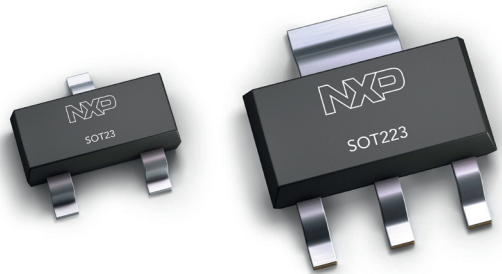

Solutions for your demand

Complexity

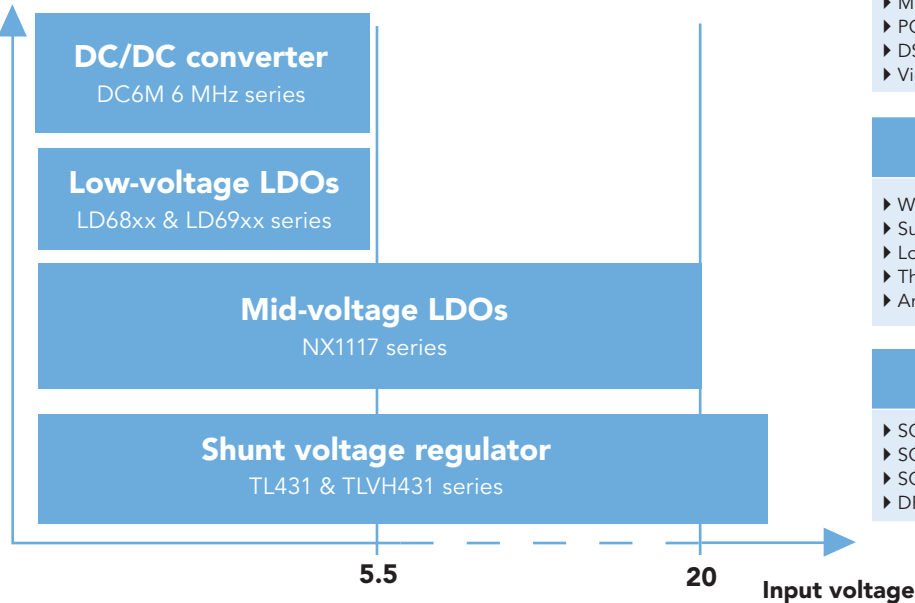

Solutions for different markets

- | | | |
|-----------------|--------------|-----------------|
| ▶ Mobile phones | ▶ Game pads | ▶ LCD TV |
| ▶ PC tablets | ▶ Notebooks | ▶ Set top box |
| ▶ DSCs | ▶ Netbooks | ▶ Power adaptor |
| ▶ Video cameras | ▶ Ultrabooks | ▶ Shaver |

Solutions for different applications

- ▶ Wide range of input & output voltages
- ▶ Supply currents from 150 – 1.000 mA
- ▶ Low quiescent and standby currents
- ▶ Thermal shutdown, overcurrent protection, fold-back
- ▶ And even more features...

Solutions in different packages

- | | |
|-------------|---------------------|
| ▶ SOT23 | ▶ DFN1010C-4 |
| ▶ SOT753 | ▶ WLCSP4 |
| ▶ SOT223 | ▶ WLCSP6 |
| ▶ DFN1410-6 | ▶ And more packages |

NXP, your one-stop-shop for high-quality products, supplies an attractive portfolio of **standard linear devices**.

Solutions for every market

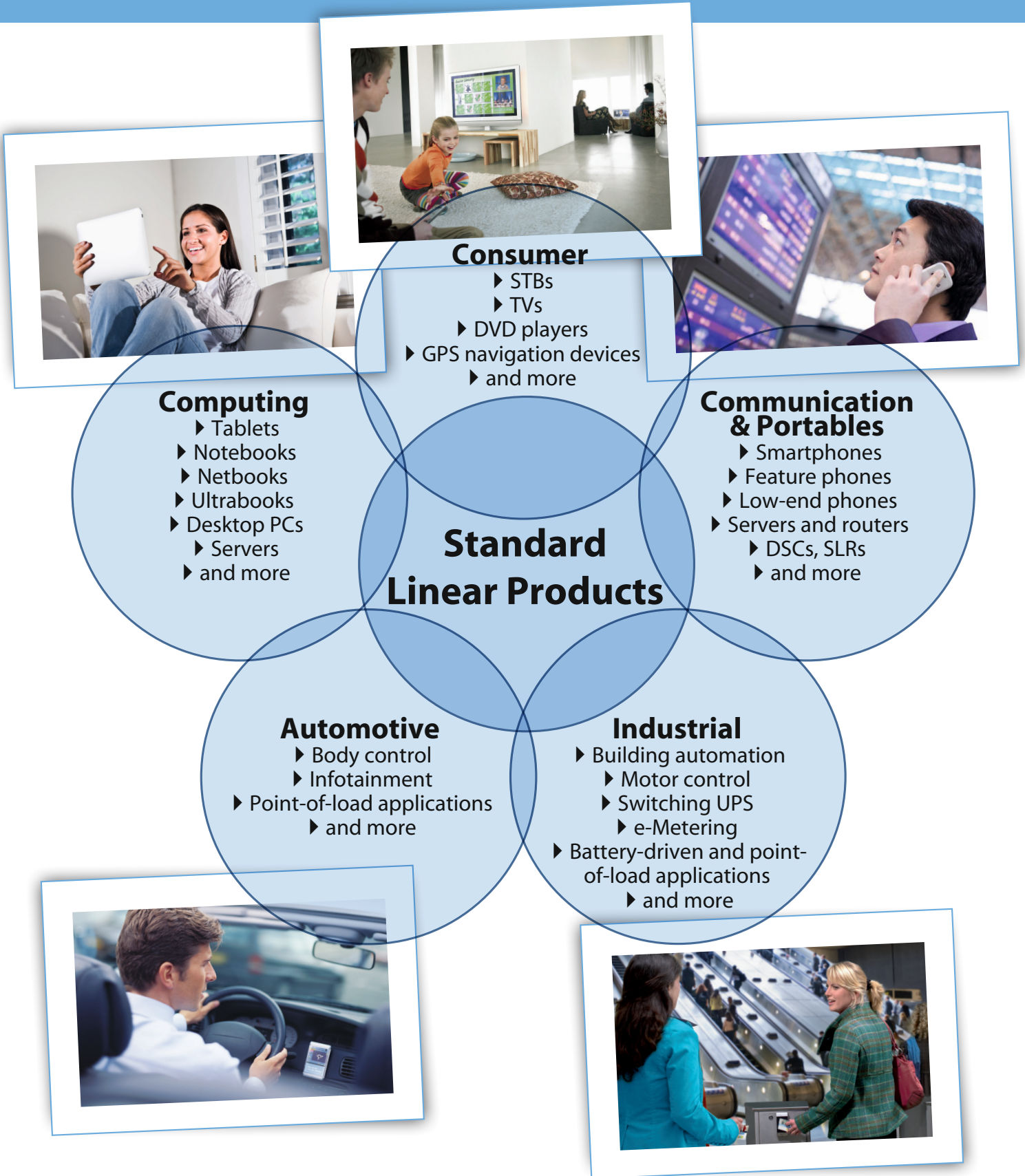

Application block diagrams

Product Examples

LD6836CX4
300 mA LV LDO
low-dropout
WLCSP4



LD6915LX
2x150 mA LV LDO
Dual-channel
DFN1212-6



DC6M series
650 mA DC/DC
6 MHz, step-down
WLCSP6



Mobile phone

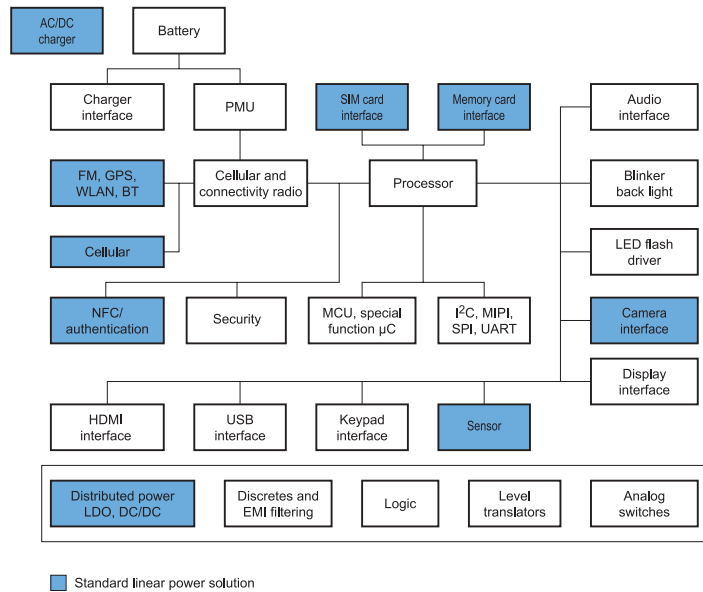

Product Examples

LD6815TD
150 mA LV LDO
High PSRR
SOT753
(SOT23-5)



NX1117 series
1 A MV LDO
1% output
tolerance
SOT23



TL431 series
 $V_{REF} = 2.495 V$
0.5% tolerance
SOT23



Set Top Box

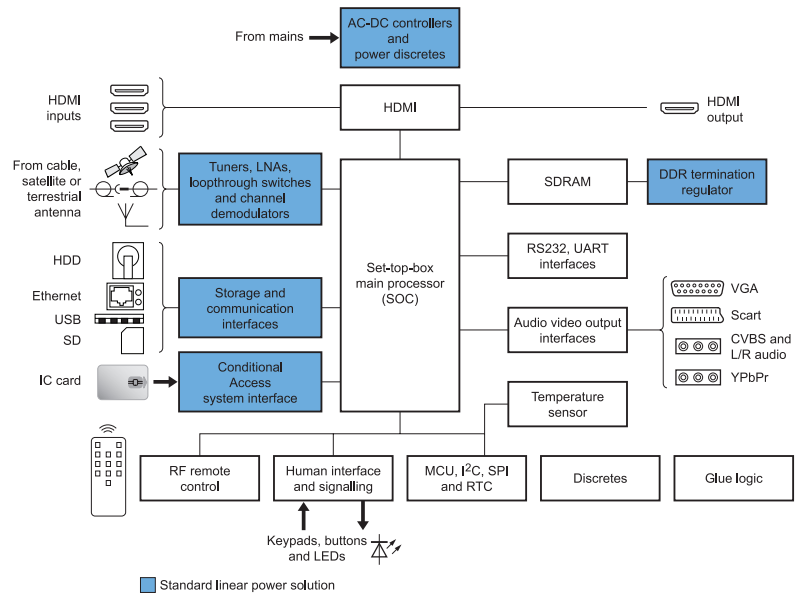

Computing

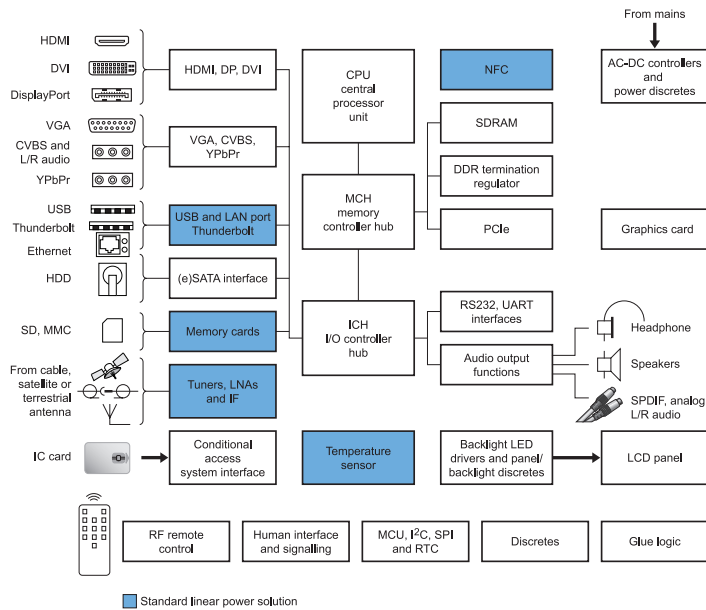

Product Examples

LD6805K
150 mA LV LDO
high PSRR
DFN1010C-4

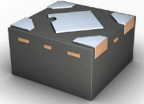

TL431 series
 $V_{REF} = 2.495V$
0.5% tolerance
SOT23



LD6806F
200 mA LV LDO
low-voltage
DFN1410-6



Industry

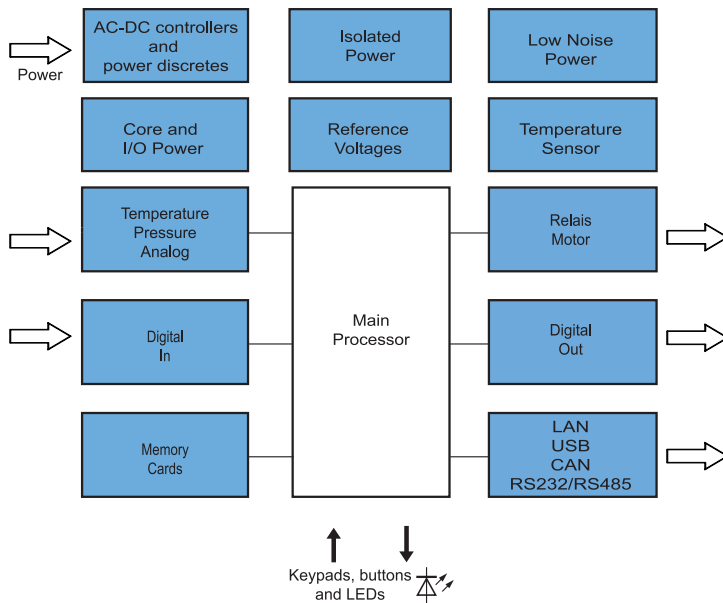

Product Examples

NX1117 series
1 A MV LDO
1% tolerance
SOT223



LD6836TD
300 mA LV LDO
low-dropout
SOT753



DC6M Series
650 mA DC/DC
6 MHz, step-down
WLCSP6



Application boards

Single-channel LDOs

Features

- ▶ Three package types available: CSP, leadless DFN, leaded
- ▶ Three different output voltages on the board
- ▶ Application-level design includes capacitors
- ▶ EN jumper for EN-Pin
- ▶ Layout available
- ▶ Supply voltage range: 2.3 to 5.5 V

Products & packages

- ▶ LD6806TD SOT753 (SOT23-5)
- ▶ LD6806F DFN1410-6 (SOT886)
- ▶ LD6806CX4 WLCSP-4
- ▶ LD6805K DFN1010C-4 (SOT1194)

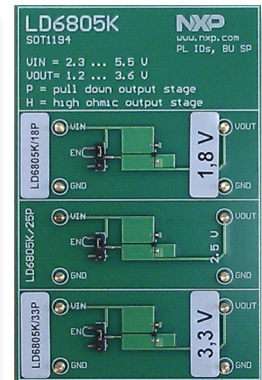
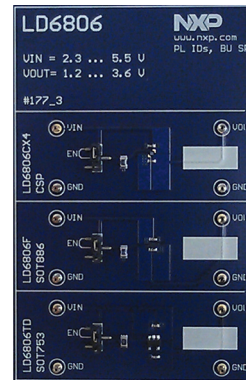

Dual-channel LDOs

Features

- ▶ Small leadless DFN & CSP packages
- ▶ Three different output voltages on the board
- ▶ EN jumper for EN-Pin
- ▶ With auto-discharge (pull-down) or high-ohmic when disabled
- ▶ Layout available
- ▶ Supply voltage range: 1.75 to 5.5 V

Products & packages

- ▶ LD6915LX DFN1212-6 (SOT1229)
- ▶ LD6935L DFN1612-8 (SOT1225)
- ▶ LD6938CX6 WLCSP6

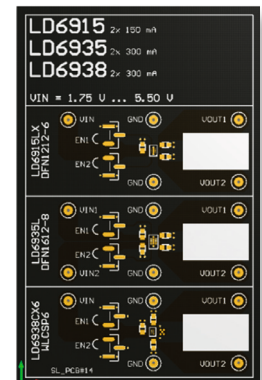

6 MHz DC/DC Step-Down Converter

Features

- ▶ Three different mode versions: (1) operation mode select (2) output voltage select (3) XSHUTDOWN/Power Good
- ▶ Three different output voltages
- ▶ Two different output currents
- ▶ Board includes choke & capacitors
- ▶ EN jumper and Mode jumper
- ▶ Supply voltage range: 2.3 to 5.5 V

Products & packages

- ▶ DC6M603X6 (XSHUTDOWN) 650 mA output current
- ▶ DC6M602X6 (Voltage select) 650 mA output current
- ▶ DC6M401X6 (Mode Select) 425 mA output current
- ▶ Package: WLCSP-6 1.36 x 0.96 x 0.47 mm

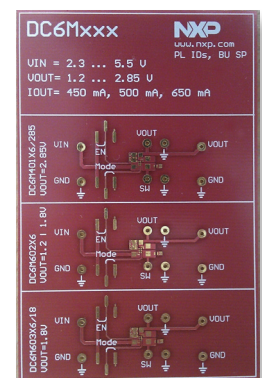

High performance in ultra small packages

Ultra small wafer-level chipscale package

Low-voltage LDO	LD68x6 series with ultra small WLCSP package and ultra low-dropout performance		
	<p>4-ball WLCSP package</p> 	<ul style="list-style-type: none"> ▶ Ultra-small package ▶ Ultra-low-dropout performance ▶ 150, 200, and 300 mA output current available ▶ Very good noise performance ▶ Very low quiescent current ▶ Thermal shutdown and overcurrent protection ▶ 0.4 mm pitch and high power dissipation 	

Package options

CSP	<p>WLCSP-4</p> 	<p>WLCSP-6</p> 	
DFN	<p>DFN1010C-4</p> 	<p>DFN1410-6</p>  <p>DFN1212-6</p> 	<p>DFN1612-8</p> 
Leaded	<p>SOT23</p>  <p>SOT223</p> 	<p>SOT753 (SOT23-5)</p> 	

3

4

5

6

8

Pins

LD6816 ultra low-dropout voltage regulators – 150 mA

Package							WLCSP4	
								
Size (mm)							0.76 × 0.76 × 0.47	
P _{tot} @°C (mW)							770	
V _{IN} (V)	I _{OUT} typ (mA)	Quiescent current (μA)	V _{do} drop @ 150 mA typ (mV)	Output noise typ (μVrms)	PSRR @ 1 kHz dB	Output voltage V*	LD6816CX4/xxH high-ohmic output stage	LD6816CX4/xxP pull-down output stage
2.3 - 5.5	150	70	45	30	55	1.2	LD6816CX4/12H	LD6816CX4/12P
						1.3	LD6816CX4/13H	LD6816CX4/13P
						1.4	LD6816CX4/14H	LD6816CX4/14P
						1.5	LD6816CX4/15H	LD6816CX4/15P
						1.6	LD6816CX4/16H	LD6816CX4/16P
						1.8	LD6816CX4/18H	LD6816CX4/18P
						2.0	LD6816CX4/20H	LD6816CX4/20P
						2.1	LD6816CX4/21H	LD6816CX4/21P
						2.2	LD6816CX4/22H	LD6816CX4/22P
						2.3	LD6816CX4/23H	LD6816CX4/23P
						2.5	LD6816CX4/25H	LD6816CX4/25P
						2.7	LD6816CX4/27H	LD6816CX4/27P
						2.8	LD6816CX4/28H	LD6816CX4/28P
						2.9	LD6816CX4/29H	LD6816CX4/29P
						3.0	LD6816CX4/30H	LD6816CX4/30P
3.3	LD6816CX4/33H	LD6816CX4/33P						
3.6	LD6816CX4/36H	LD6816CX4/36P						

* Other output voltages are available on request

Functional diagram: High-ohmic output

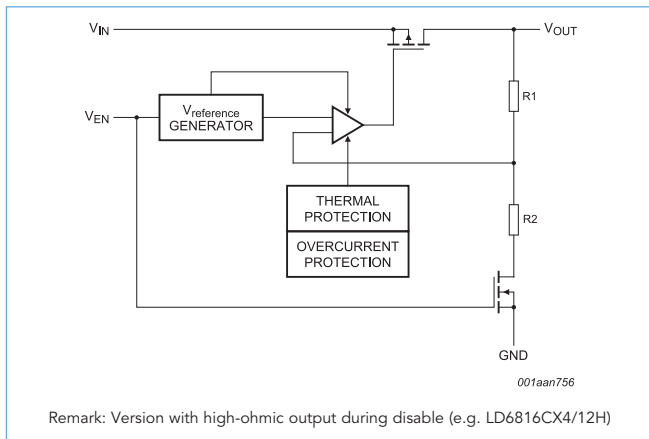

Functional diagram: Auto-discharge (pull-down)

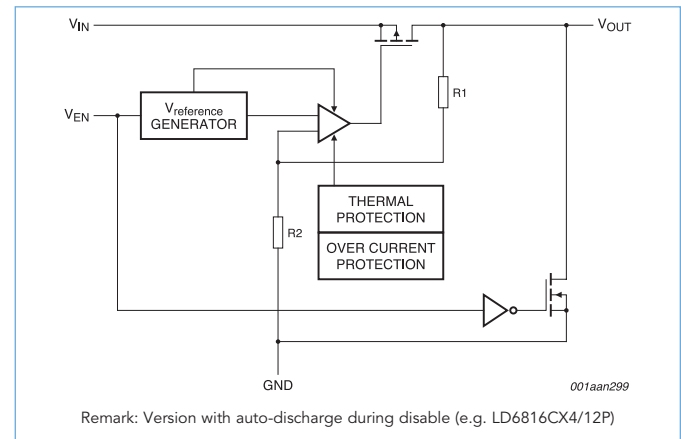

Key features

- ▶ Ultra low-dropout voltage (45 mV @ 150 mA)
- ▶ Very low output noise (30 μVrms)
- ▶ Thermal shutdown protection and current limiter

Key benefits

- ▶ Very small WLCSP package
- ▶ Very low standby and supply current for battery-powered solutions
- ▶ No additional noise bypass capacitor needed

Key applications

- ▶ Mobile phones, PC tablets, DSCs (digital still cameras), video cameras, game pads, notebooks, netbooks, ultrabooks

LDOs in ultra-small WLCSP package

State-of-the-art wafer-level chip scale technology

Dimensions of only 0.76 × 0.76 × 0.47 mm

High power dissipation of 770 mW

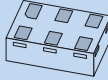
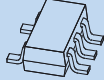

LD6806 ultra low-dropout voltage regulators – 200 mA

Package							WLCSP4	DFN1410-6 (SOT886)	SOT753			
												
Size (mm)							0.76 × 0.76 × 0.47		1.45 × 1.0 × 0.5		2.9 × 1.5 × 1.0	
P _{tot} @°C (mW)							770		450		800	
V _{IN} (V)	I _{OUT} typ (mA)	Quiescent current (μA)	V _{do} drop @ 200 mA typ (mV)	Output noise typ (μVrms)	PSRR @ 1 kHz dB	Output voltage V*	LD6806CX4/xxH high-ohmic output stage	LD6806CX4/xxP pull-down output stage	LD6806F/xxH high-ohmic output stage	LD6806F/xxP pull-down output stage	LD6806TD/xxH high-ohmic output stage	LD6806TD/xxP pull-down output stage
2.3 - 5.5	200	70	60	30	55	1.2	LD6806CX4/20H	LD6806CX4/20P	LD6806F/20H	LD6806F/20P	LD6806TD/20H	LD6806TD/20P
						1.3	LD6806CX4/21H	LD6806CX4/21P	LD6806F/21H	LD6806F/21P	LD6806TD/21H	LD6806TD/21P
						1.4	LD6806CX4/14H	LD6806CX4/14P	LD6806F/14H	LD6806F/14P	LD6806TD/14H	LD6806TD/14P
						1.5	LD6806CX4/15H	LD6806CX4/15P	LD6806F/15H	LD6806F/15P	LD6806TD/15H	LD6806TD/15P
						1.6	LD6806CX4/16H	LD6806CX4/16P	LD6806F/16H	LD6806F/16P	LD6806TD/16H	LD6806TD/16P
						1.8	LD6806CX4/18H	LD6806CX4/18P	LD6806F/18H	LD6806F/18P	LD6806TD/18H	LD6806TD/18P
						2.0	LD6806CX4/20H	LD6806CX4/20P	LD6806F/20H	LD6806F/20P	LD6806TD/20H	LD6806TD/20P
						2.1	LD6806CX4/21H	LD6806CX4/21P	LD6806F/21H	LD6806F/21P	LD6806TD/21H	LD6806TD/21P
						2.2	LD6806CX4/22H	LD6806CX4/22P	LD6806F/22H	LD6806F/22P	LD6806TD/22H	LD6806TD/22P
						2.3	LD6806CX4/23H	LD6806CX4/23P	LD6806F/23H	LD6806F/23P	LD6806TD/23H	LD6806TD/23P
						2.5	LD6806CX4/25H	LD6806CX4/25P	LD6806F/25H	LD6806F/25P	LD6806TD/25H	LD6806TD/25P
						2.7	LD6806CX4/27H	LD6806CX4/27P	LD6806F/27H	LD6806F/27P	LD6806TD/27H	LD6806TD/27P
						2.8	LD6806CX4/28H	LD6806CX4/28P	LD6806F/28H	LD6806F/28P	LD6806TD/28H	LD6806TD/28P
						2.9	LD6806CX4/29H	LD6806CX4/29P	LD6806F/29H	LD6806F/29P	LD6806TD/29H	LD6806TD/29P
						3.0	LD6806CX4/30H	LD6806CX4/30P	LD6806F/30H	LD6806F/30P	LD6806TD/30H	LD6806TD/30P
						3.3	LD6806CX4/33H	LD6806CX4/33P	LD6806F/33H	LD6806F/33P	LD6806TD/33H	LD6806TD/33P
3.6	LD6806CX4/36H	LD6806CX4/36P	LD6806F/36H	LD6806F/36P	LD6806TD/36H	LD6806TD/36P						

* Other output voltages are available on request

Key features

- ▶ Ultra low-dropout voltage (60 mV @ 200 mA)
- ▶ Very low output noise (30 μVrms)
- ▶ Thermal shutdown protection and current limiter

Key benefits

- ▶ Very small WLCSP package
- ▶ Very low standby and supply current for battery-powered solutions
- ▶ No additional noise bypass capacitor needed

Key applications

- ▶ Mobile phones, PC tablets, DSCs (digital still cameras), video cameras, game pads, notebooks, netbooks, ultrabooks

Part numbering for LDOs

LDO Naming Convention

LD6xxxX/xx[H; P]

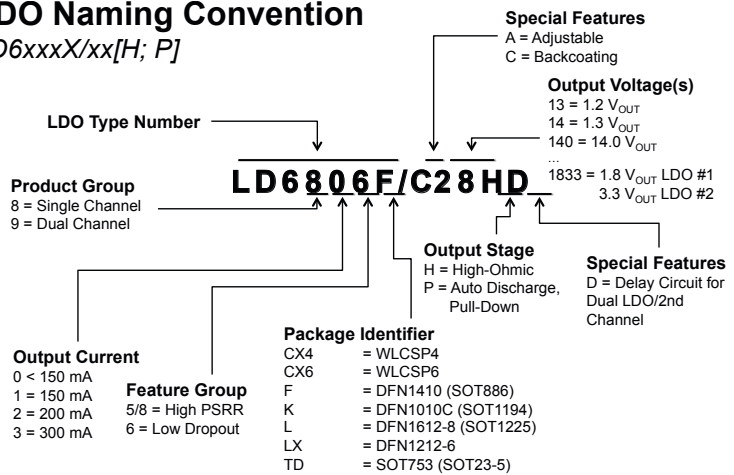

In the spotlight

- LDOs in very small DFN package**
- State-of-the-art dual-flat no-leads (DFN) package technology
- Dimensions of only 1.45 x 1.0 x 0.5 mm
- High power dissipation of 450 mW

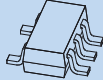

LD6836 ultra low-dropout voltage regulators – 300 mA

Package							WLCSP4		SOT753	
										
Size (mm)							0.76 × 0.76 × 0.47		2.9 × 1.5 × 1.0	
P _{tot} @ °C (mW)							770		800	
V _{IN} (V)	I _{OUT} typ (mA)	Quiescent current (μA)	V _{do} drop @ 300 mA typ (mV)	Output noise typ (μVrms)	PSRR @ 1 kHz dB	Output voltage v*	LD6836CX4/xxH High ohmic output stage	LD6836CX4/xxP Pull down output stage	LD6836TD/xxH High ohmic output stage	LD6836TD/xxP Pull down output stage
2.3 - 5.5	300	70	90	30	55	1.2	LD6836CX4/12H	LD6836CX4/12P	LD6836TD/12H	LD6836TD/12P
						1.3	LD6836CX4/13H	LD6836CX4/13P	LD6836TD/13H	LD6836TD/13P
						1.4	LD6836CX4/14H	LD6836CX4/14P	LD6836TD/14H	LD6836TD/14P
						1.5	LD6836CX4/15H	LD6836CX4/15P	LD6836TD/15H	LD6836TD/15P
						1.6	LD6836CX4/16H	LD6836CX4/16P	LD6836TD/16H	LD6836TD/16P
						1.8	LD6836CX4/18H	LD6836CX4/18P	LD6836TD/18H	LD6836TD/18P
						2.0	LD6836CX4/20H	LD6836CX4/20P	LD6836TD/20H	LD6836TD/20P
						2.1	LD6836CX4/21H	LD6836CX4/21P	LD6836TD/21H	LD6836TD/21P
						2.2	LD6836CX4/22H	LD6836CX4/22P	LD6836TD/22H	LD6836TD/22P
						2.3	LD6836CX4/23H	LD6836CX4/23P	LD6836TD/23H	LD6836TD/23P
						2.5	LD6836CX4/25H	LD6836CX4/25P	LD6836TD/25H	LD6836TD/25P
						2.7	LD6836CX4/27H	LD6836CX4/27P	LD6836TD/27H	LD6836TD/27P
						2.8	LD6836CX4/28H	LD6836CX4/28P	LD6836TD/28H	LD6836TD/28P
						2.9	LD6836CX4/29H	LD6836CX4/29P	LD6836TD/29H	LD6836TD/29P
						3.0	LD6836CX4/30H	LD6836CX4/30P	LD6836TD/30H	LD6836TD/30P
3.3	LD6836CX4/33H	LD6836CX4/33P	LD6836TD/33H	LD6836TD/33P						
3.6	LD6836CX4/36H	LD6836CX4/36P	LD6836TD/36H	LD6836TD/36P						

* Other output voltages are available on request

Functional diagram: High-ohmic output

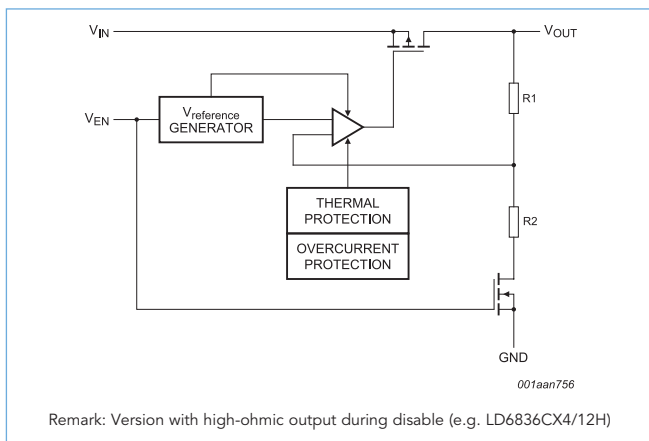

Functional diagram: Auto-discharge (pull-down)

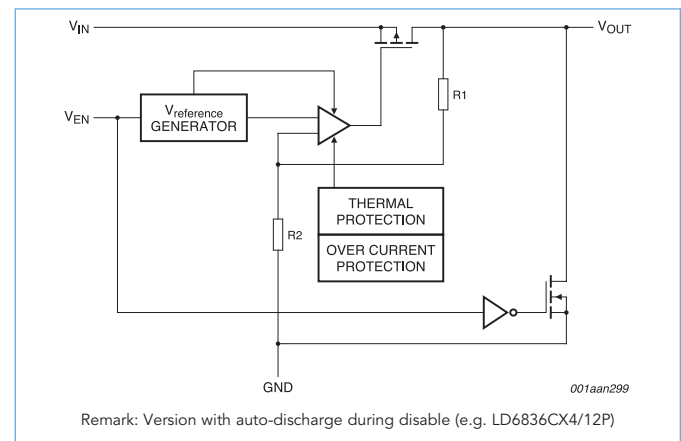

Key features

- ▶ Ultra low-dropout voltage (90 mV @ 300 mA)
- ▶ Very low output noise (30 μVrms)
- ▶ Thermal shutdown protection and current limiter

Key benefits

- ▶ Very small WLCSP package
- ▶ Very low standby and supply current for battery-powered solutions
- ▶ No additional noise bypass capacitor needed

Key applications

- ▶ Mobile phones, PC tablets, DSCs (digital still cameras), video cameras, game pads, notebooks, netbooks, ultrabooks

In the spotlight

SOT753 general purpose package

General purpose package SOT753 (SOT23-5 footprint)

Dimensions of only 2.9 × 1.5 × 1.0 mm

Very high power dissipation of 800 mW



LD6805 and LD6815 high-PSRR low-dropout voltage regulators – 150 mA

types in **bold** represent new products

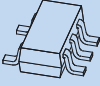
Package							DFN1010C-4 (SOT1194)		SOT753	
										
Size (mm)							1.0 x 1.0 x 0.55		2.9 x 1.5 x 1.0	
P _{tot} @ °C (mW)							400		800	
V _{IN} (V)	I _{OUT} typ (mA)	Quiescent current (μA)	V _{do} drop @ 150 mA typ (mV)	Output noise typ (μVrms)	PSRR @ 1 kHz dB	Output voltage V*	LD6805K/xxH high-ohmic output stage	LD6805K/xxP pull-down output stage	LD6815TD/xxH high-ohmic output stage	LD6815TD/xxP pull-down output stage
2.3 - 5.5	150	35	250	40	75	1.2	LD6805K/12H	LD6805K/12P	LD6815TD/12H	LD6815TD/12P
						1.3	LD6805K/13H	LD6805K/13P		
						1.4	LD6805K/14H	LD6805K/14P	-	-
						1.5	LD6805K/15H	LD6805K/15P	LD6815TD/15H	LD6815TD/15P
						1.6	LD6805K/16H	LD6805K/16P	-	-
						1.8	LD6805K/18H	LD6805K/18P	LD6815TD/18H	LD6815TD/18P
						1.85	LD6805K/185H	-	-	-
						2.0	LD6805K/20H	LD6805K/20P	-	-
						2.1	LD6805K/21H	LD6805K/21P	LD6815TD/21H	LD6815TD/21P
						2.2	LD6805K/22H	LD6805K/22P	-	-
						2.3	LD6805K/23H	LD6805K/23P	-	-
						2.5	LD6805K/25H	LD6805K/25P	LD6815TD/25H	LD6815TD/25P
						2.8	LD6805K/28H	LD6805K/28P	LD6815TD/28H	LD6815TD/28P
						2.9	LD6805K/29H	LD6805K/29P	LD6815TD/29H	LD6815TD/29P
						3.0	LD6805K/30H	LD6805K/30P	LD6815TD/30H	LD6815TD/30P
						3.1	LD6805K/31H	LD6805K/31P	-	-
3.3	LD6805K/33H	LD6805K/33P	LD6815TD/33H	LD6815TD/33P						
3.6	LD6805K/36H	LD6805K/36P	LD6815TD/36H	LD6815TD/36P						

* Other output voltages are available on request

Functional diagram: High-ohmic output

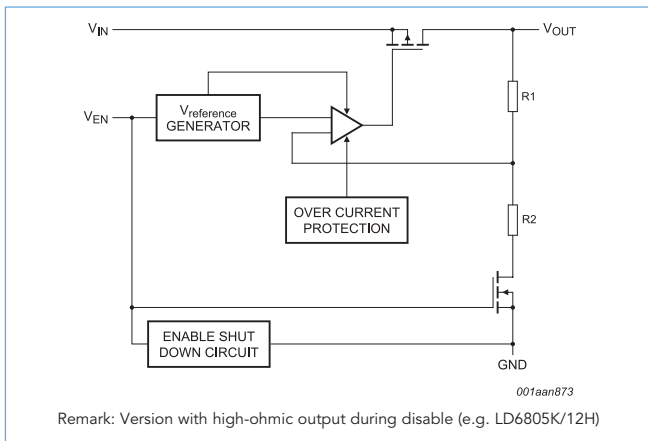

Functional diagram: Auto-discharge (pull-down)

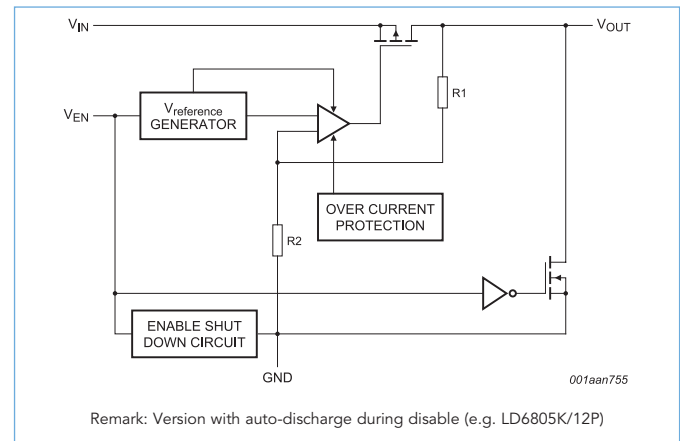

Key features

- ▶ High power supply ripple rejection (PSRR)
- ▶ Very low quiescent current and low noise (40 μVrms)
- ▶ Small package size

Key benefits

- ▶ Very small package for mobile applications
- ▶ Very low standby and supply current for battery-powered solutions
- ▶ No additional noise bypass capacitor needed

Key applications

- ▶ Mobile phones, PC tablets, DSCs (digital still cameras), video cameras, game pads, notebooks, netbooks, ultrabooks

In the spotlight

High-PSRR LDO in very small DFN package

State-of-the-art dual-flat no-leads (DFN) package technology

Dimensions of only 1.0 x 1.0 x 0.55 mm

High power dissipation of 400 mW



LD6835 high-PSRR low-dropout voltage regulators – 300 mA

Package							DFN1010C-4 (SOT1194)	
								
Size (mm)							1.0 x 1.0 x 0.55 mm	
P _{tot} @ °C (mW)							400	
V _{IN} (V)	I _{OUT} typ (mA)	Quiescent current (μA)	V _{do} drop @ 300 mA typ (mV)	Output noise typ (μVrms)	PSRR @ 1 kHz dB	Output voltage V*	LD6835K/xxH high-ohmic output stage	LD6835K/xxP pull-down output stage
1.75 - 5.5	300	30	240	50	75	1.2	LD6835K/12H	LD6835K/12P
						1.4	LD6835K/14H	LD6835K/14P
						1.5	LD6835K/15H	LD6835K/15P
						1.8	LD6835K/18H	LD6835K/18P
						2.5	LD6835K/25H	LD6835K/25P
						2.6	LD6835K/26H	LD6835K/26P
						2.8	LD6835K/28H	LD6835K/28P
						2.85	-	LD6835K/285P
						2.9	LD6835K/29H	LD6835K/29P
						3.0	LD6835K/30H	LD6835K/30P
						3.1	LD6835K/31H	LD6835K/31P
						3.3	LD6835K/33H	LD6835K/33P
3.6	LD6835K/36H	LD6835K/36P						

* Other output voltages are available on request

Key features

- ▶ High power supply ripple rejection (PSRR)
- ▶ Very low quiescent current (30 μA) and low noise (50 μVrms)
- ▶ Small package size

Key benefits

- ▶ Very small package for mobile application
- ▶ Very low standby and supply current for battery-powered solutions
- ▶ No additional noise bypass capacitor needed

Key applications

- ▶ Mobile phones, tablet PCs, DSCs (digital still cameras), video cameras, game pads, notebooks, netbooks, ultrabooks

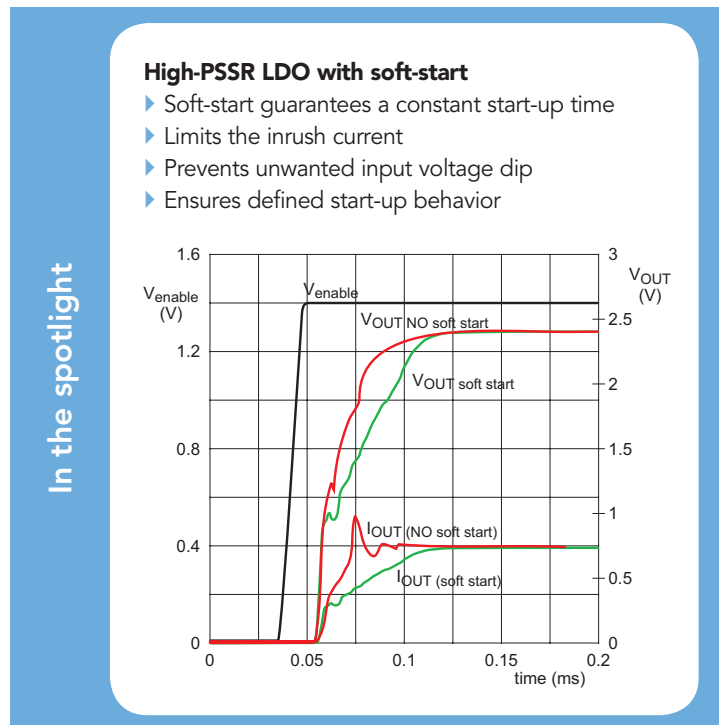

LD6915, LD6935 and LD6938 dual high-PSRR low-dropout voltage regulators - 150 mA and 300 mA

Package		DFN1212-6 (SOT1229)				DFN1612-8 (SOT1225)		WLCSP6		
Size (mm)		1.2 x 1.2 x 0.4 mm				1.6 x 1.2 x 0.4 mm		1.2 x 0.8 x 0.47 mm		
P _{tot} @°C (mW)		400				600		800		
V _{IN} (V)	Quiescent current (µA)	Output noise typ (µVrms)	PSRR @ 1kHz (dB)	I _{OUT} typ (mA)	V _{DO} drop @ 300 mA typ (mV)	Output voltage (V)*				
1.75 - 5.5	30	50	75	2 x 150 (LD6915)	120 (LD6915)	1.2/1.2	-	-	-	LD6938CX6/1212P
						1.2/1.5	-	-	-	LD6938CX6/1215P
						1.2/1.8	-	-	-	LD6938CX6/1218P
						1.5/2.8	-	-	LD6935L/1528H	LD6935L/1528P
						1.8/1.5	-	LD6915LX/1815P	-	-
						1.8/1.8	-	LD6915LX/1818P	-	-
						1.8/1.25	-	-	-	-
						1.8/2.8	-	LD6915LX/1828P	-	LD6935L/1828P
						1.8/3.3	-	-	-	-
						2.8/1.8	-	LD6915LX/2818P	LD6915LX/2818PD	-
						2.8/2.8	-	-	LD6935L/2828H	-
						2.85/1.8	-	-	-	-
						2.85/3.0	-	-	-	-
						3.0/1.8	-	LD6915LX/3018P	-	LD6935L/3018H
						3.0/2.8	LD6915LX/3028H	LD6915LX/3028P	-	LD6935L/3030P
						3.0/3.0	-	-	-	LD6935L/3030P
						3.1/1.7	-	-	-	LD6935L/3117P
						3.1/3.1	-	-	-	LD6935L/3131P
						3.3/1.25	-	-	-	-
						3.3/1.8	-	LD6915LX/3318P	-	LD6935L/3318H
						3.3/2.8	LD6915LX/3328H	LD6915LX/3328P	LD6915LX/3328HD	-
						3.3/2.85	-	-	-	LD6938CX6/33285H
						3.3/3.0	-	-	-	LD6938CX6/33285P
						3.3/3.3	-	LD6915LX/3333P	-	LD6935L/3333P
						3.6/1.2	-	LD6915LX/3612P	-	-
										LD6938CX6/3612H

* Other output voltages are available on request ** optionally available with delay circuit

Functional diagram: High-ohmic output

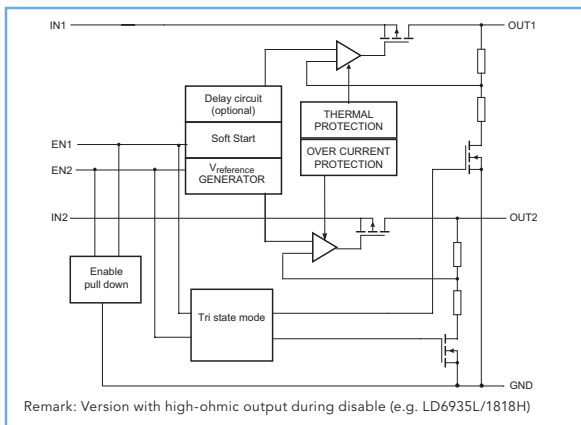

Functional diagram: Auto-discharge (pull-down)

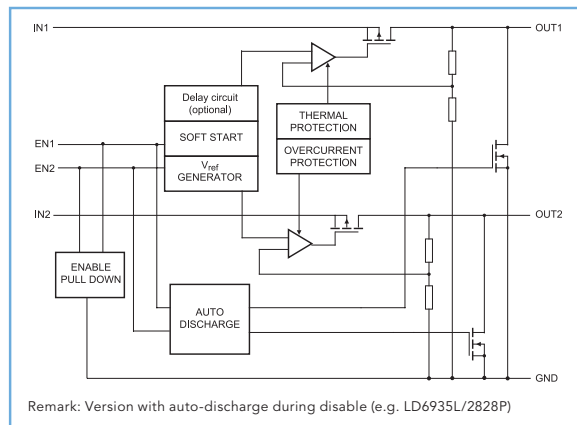

Key features

- ▶ High power supply ripple rejection (PSRR)
- ▶ Very low quiescent current (30 µA)
- ▶ Soft-start, thermal shutdown, foldback, current limiter, optional with delay circuit

Key benefits

- ▶ Very low standby and supply current for battery-powered solutions
- ▶ Small packages for board space reduction
- ▶ No additional noise bypass capacitor needed

Key applications

- ▶ Mobile phones, tablet PCs, DSCs (digital still cameras), video cameras, game pads, notebooks, netbooks, ultrabooks

Delay Circuit

- ▶ The delay circuit prevents an unwanted input voltage dip when both outputs are enabled at the same time by delaying the second LDO

In the spotlight

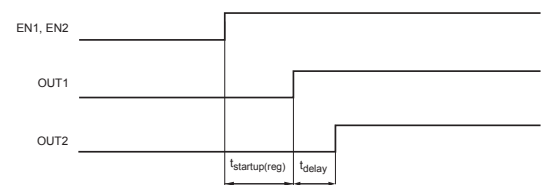

NX1117 low-dropout adjustable and fixed linear voltage regulator

types in **bold** represent new products

Package				SOT223 (SC-73)		
						
Size (mm)				6.5 x 3.5 x 1.65		
P _{tot} (mW)				1700		
						AEC-Q100 qualified
V _{max} (V)	I _{max} (A)	V _{out} drop (V) @ 800 mA	V _{out} (V)	V _{out} tolerance		V _{out} tolerance
				1%	1.25%	1%
20	1	1.1	1.25 adjustable	NX1117CADJZ	NX1117CEADJZ	NX1117IADJZ
			1.2	NX1117C12Z	NX1117CE12Z	NX1117I12Z
			1.5	NX1117C15Z	NX1117CE15Z	NX1117I15Z
			1.8	NX1117C18Z	NX1117CE18Z	NX1117I18Z
			1.9	NX1117C19Z	NX1117CE19Z	NX1117I19Z
			2.0	NX1117C20Z	NX1117CE20Z	NX1117I20Z
			2.5	NX1117C25Z	NX1117CE25Z	NX1117I25Z
			2.85	NX1117C285Z	NX1117CE285Z	NX1117I285Z
			3.3	NX1117C33Z	NX1117CE33Z	NX1117I33Z
			5.0	NX1117C50Z	NX1117CE50Z	NX1117I50Z
		12.0	-	-	NX1117I120Z	

NX1117x33Z: Typical application for fixed output voltage versions

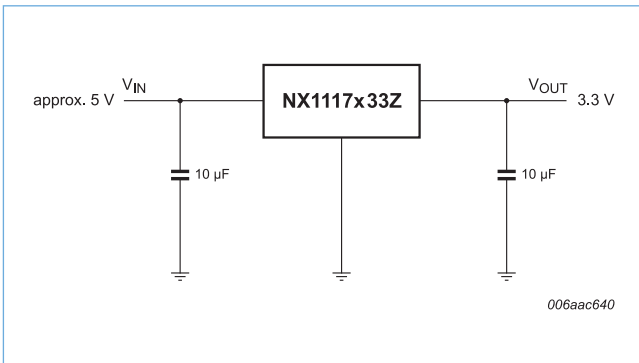

NX1117xADJZ: Typical application for adjustable output voltage versions

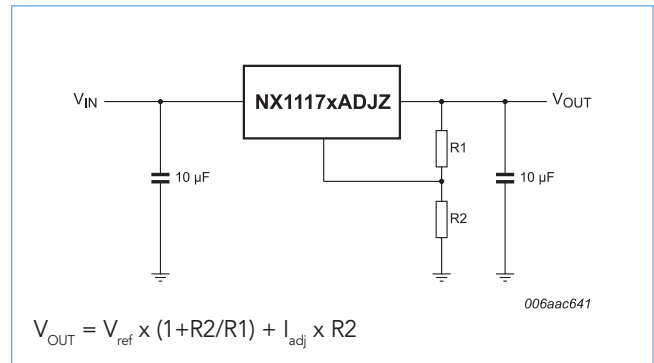

Key applications

- ▶ Post regulation for SMPS
- ▶ Automotive, industrial, and consumer equipment point of load
- ▶ Battery charger
- ▶ Hard-drive controllers
- ▶ Core voltage supply: FPGA, PLD, DSP, CPU
- ▶ LCD TV
- ▶ Set-top box
- ▶ DVD player
- ▶ Automotive multimedia

In the spotlight

NX1117i low-dropout linear voltage regulator

- Adjustable or fixed output voltage options with 1% accuracy in SOT223
- Wide input voltage range up to 20 V
- Maximum output current of 1 A
- Output current limiting and thermal shutdown
- Temperature range from -40 to 125 °C
- AEC-Q100 qualified (grade 1)

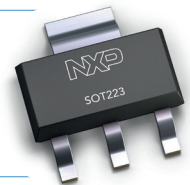

DC6M401, DC6M402 small size 6 MHz DC/DC buck converter – 425 mA

types in **bold** represent new products

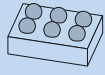
Package							WLCSP6	
								
Size (mm)							1.36 x 0.96 x 0.47	
P _{tot} @ °C							800	
V _{IN} (V)	I _{OUT} (mA)	Operation frequency (MHz)	Quiescent current typ (µA)	Output voltage ripple typ (mV)	Efficiency up to (%)	Output voltage V*	DC6M401/xxxS Modulation select	DC6M402/xxxxxA Voltage select auto modulation
2.3 - 5.5	425	6	0.2	7	95	1.8	DC6M401X6/18S	-
						2.85	DC6M401X6/285S	-
						1.8 / 2.85	-	DC6M402X6/18285A

* Other output voltages are available on request

Functional diagram

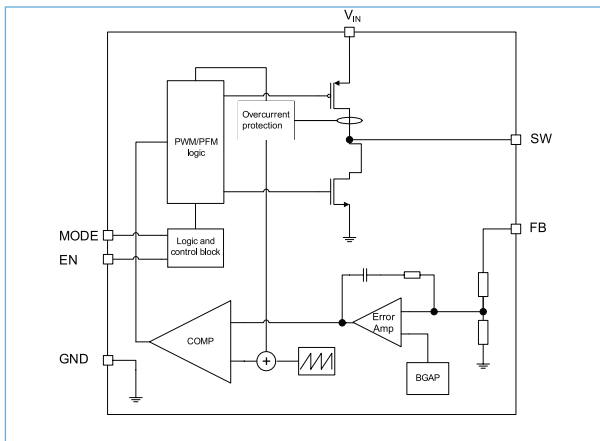

Part numbering for DC/DC converter

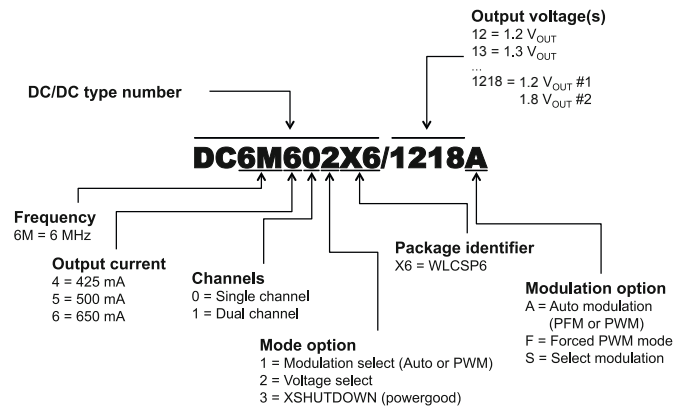

Key features

- ▶ True 6 MHz operation frequency
- ▶ Very high efficiency of up to 95%
- ▶ Inrush current limiter (soft start)
- ▶ Protection through thermal shutdown and current limiter
- ▶ Ultra-low output ripple of 7 mV (typ)

Key benefits

- ▶ Very small WLCSP package for board space reduction
- ▶ Only very small inductor or PCB R-coil needed (470 nH)
- ▶ Optimized for SD card and SIM card applications

Key applications

- ▶ Mobile phones, PC tablets, DSCs (digital still cameras), video cameras, game pads, notebooks, netbooks, ultrabooks
- ▶ Battery operated applications requiring a lower-than-battery-voltage supply with high currents and high-efficiency down conversion

In the spotlight

6 MHz DC/DC buck converter in WLCSP package

High frequency (6 MHz) allows usage of small 470 nH inductor

3 mode types available (PWM/PFM, voltage select, XSHUTDOWN)

Very high efficiency of up to 95%

425 mA, 500 mA and 650 mA output currents available

Very small package → Wafer-level chip scale package



DC6M501, DC6M502, DC6M503 small size 6 MHz DC/DC buck converter – 500 mA

types in **bold** represent new products

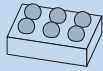
Package							WLCSP6			
										
Size (mm)							1.36 x 0.96 x 0.47			
P _{tot} @ °C							800			
V _{IN} (V)	I _{OUT} (mA)	Operation frequency (MHz)	Quiescent current typ (µA)	Output voltage ripple typ (mV)	Efficiency up to (%)	Output voltage V*	DC6M501/xxxS Modulation select	DC6M502/xxxxxA Voltage select auto modulation	DC6M502/xxxxxF Voltage select forced PWM	DC6M503/xxxA XSHUTDOWN Auto modulation
2.3 - 5.5	500	6	0.2	7	95	1,2	DC6M501X6/125	-	-	DC6M503X6/12A
						1,5	DC6M501X6/155	-	-	DC6M503X6/15A
						1,8	DC6M501X6/185	-	-	DC6M503X6/18A
						1.2 / 1.5	-	DC6M502X6/1215A	DC6M502X6/1215F	-
						1.2 / 1.8	-	DC6M502X6/1218A	DC6M502X6/1218F	-
						1.5 / 1.8	-	DC6M502X6/1518A	DC6M502X6/1518F	-

* Other output voltages are available on request

Key features

- ▶ True 6 MHz operation frequency
- ▶ Ultra-low output ripple of 7 mV (typ)
- ▶ Very high efficiency of up to 95%
- ▶ Inrush current limiter (soft start)
- ▶ Protection through thermal shutdown and current limiter

Key benefits

- ▶ Very small WLCSP package for board space reduction

- ▶ Only very small inductor or PCB R-coil needed (470 nH)
- ▶ Supports SMIA standard (XSHUTDOWN/powergood)

Key applications

- ▶ Mobile phones, tablet PCs, DSCs (digital still cameras), video cameras, game pads, notebooks, netbooks, ultrabooks
- ▶ Battery operated applications requiring a lower-than-battery-voltage supply with high currents and high-efficiency down conversion

DC6M601, DC6M602, DC6M603 small size 6 MHz DC/DC buck converter – 650 mA

types in **bold** represent new products

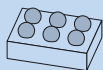
Package							WLCSP6			
										
Size (mm)							1.36 x 0.96 x 0.47			
P _{tot} @ °C							800			
V _{IN} (V)	I _{OUT} (mA)	Operation frequency (MHz)	Quiescent current typ (µA)	Output voltage ripple typ (mV)	Efficiency up to (%)	Output voltage V*	DC6M601/xxS Modulation select	DC6M602/xxxxxA Voltage select auto modulation	DC6M602/xxxxxF Voltage select forced PWM	DC6M603/xxxA XSHUTDOWN Auto modulation
2.3 - 5.5	650	6	0.2	7	95	1,2	DC6M601X6/125	-	-	DC6M603X6/12A
						1,5	DC6M601X6/155	-	-	DC6M603X6/15A
						1,8	DC6M601X6/185	-	-	DC6M603X6/18A
						2,85	DC6M601X6/285S	-	-	-
						1.2 / 1.5	-	DC6M602X6/1215A	DC6M602X6/1215F	-
						1.2 / 1.8	-	DC6M602X6/1218A	DC6M602X6/1218F	-
1.5 / 1.8	-	DC6M602X6/1518A	DC6M602X6/1518F	-						

* Other output voltages are available on request

Key features

- ▶ True 6 MHz operation frequency
- ▶ Very high efficiency of up to 95%
- ▶ Inrush current limiter (soft start)
- ▶ Protection through thermal shutdown and current limiter
- ▶ Ultra-low output ripple of 7 mV (typ)

Key benefits

- ▶ Very small WLCSP package for board space reduction

- ▶ Only a very small inductor or PCB R-coil is needed (470 nH)
- ▶ Supports SMIA standard (XSHUTDOWN/powergood)

Key applications



- ▶ Mobile phones, tablet PCs, DSCs (digital still cameras), video cameras, game pads, notebooks, netbooks, ultrabooks
- ▶ Battery operated applications requiring a lower-than-battery-voltage supply with high currents and high-efficiency down conversion

TL431 adjustable shunt voltage regulator with $V_{ref} = 2.495\text{ V}$

				SOT23		
Package						
Size (mm)				2.9 x 1.3 x 1.0		
P _{tot} (mW)				580		
Pinning configuration				Normal pinning*	Mirrored pinning*	
V _{KA} (V)	I _K (mA)	V _{ref}	T _{amb} (°C)			
36	100	2.495	2%	0 to 70	TL431CDBZR ¹⁾	
				-40 to 85	TL431IDBZR ¹⁾	
				-40 to 125	TL431QDBZR ¹⁾	
					TL431FDT ²⁾	TL431MFDT ²⁾
					TL431SDT ³⁾	TL431MSDT ³⁾
					TL431ACDBZR ¹⁾	
			1%	-40 to 85	TL431AIDBZR ¹⁾	
				-40 to 125	TL431AQDBZR ¹⁾	
					TL431AFDT ²⁾	TL431AMFDT ²⁾
					TL431ASDT ³⁾	TL431AMSDT ³⁾
					TL431BCDBZR ¹⁾	
				0.5%	0 to 70	TL431BCDBZR ¹⁾
-40 to 85	TL431BIDBZR ¹⁾					
-40 to 125	TL431BQDBZR ¹⁾					
	TL431BFDT ²⁾	TL431BMFDT ²⁾				
	TL431BSDT ³⁾	TL431BMSDT ³⁾				

¹⁾ Offers enhanced stability area and very low load capacity requirement
²⁾ Offers higher ElectroMagnetic Interference (EMI) ruggedness, e.g. for Switch Mode Power Supply
³⁾ Is designed for standard requirements and linear applications

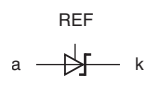
* Normal pinning vs. mirrored pinning for TL431

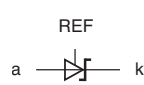
	Pin	Symbol	Description	Simplified outline	Graphic symbol
Normal pinning	1	k	cathode		
	2	REF	reference		
	3	a	anode		
Mirrored pinning	1	REF	reference		
	2	k	cathode		
	3	a	anode		

Key benefits

- ▶ Simple solution to achieve a stabilized voltage
- ▶ Any output voltage from 2.5 to 36 V can be set by just two external resistors
- ▶ Full temperature range from -40 to 125 °C
- ▶ Low temperature drift: typically 6 mV (between 0 and 70 °C)
- ▶ Low output noise
- ▶ High quality level according AEC-Q100

Key applications

- ▶ Shunt voltage regulator
- ▶ Precision current limiter
- ▶ Precision constant current sink
- ▶ Isolated feedback loop for Switch Mode Power Supply (SMPS)

Functional diagram

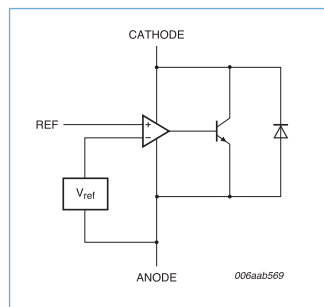

Shunt voltage regulator

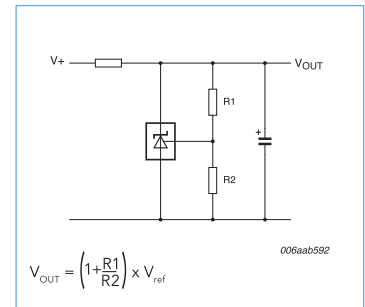







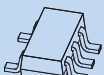

Any voltage in the given range can be set by only 2 external resistors

TLVH431 adjustable shunt voltage regulator with $V_{ref} = 1.24V$

types in **bold** represent new products

Package				SOT23		SOT753	
							
Size (mm)				2.9 x 1.3 x 1.0		2.9 x 1.5 x 1.0	
P _{tot} (mW)				480		450	
Pinning configuration				Normal pinning*		Mirrored pinning*	
V _{KA} (V)	I _K (mA)	V _{ref}		T _{amb} (°C)			
20	80	1.24	1.5%	0 to 70	TLVH431CDBZR		
				-40 to 85	TLVH431IDBZR		
				-40 to 125	TLVH431QDBZR	TLVH431MQDBZR	TLVH431QDBVR
			1%	0 to 70	TLVH431ACDBZR		
				-40 to 85	TLVH431AIDBZR		
				-40 to 125	TLVH431AQDBZR	TLVH431AMQDBZR	TLVH431AQDBVR
0.75%	-40 to 125	TLVH431DQDBZR	TLVH431DMQDBZR	TLVH431DQDBVR			

*Normal pinning vs. mirrored pinning for TLVH431

	Pin	Symbol	Description	Simplified outline	Grafic symbol
 SOT23 Normal pinning	1	REF	reference		REF a —  — k
	2	k	cathode		
	3	a	anode		
 SOT23 Mirrored pinning	1	k	cathode		REF a —  — k
	2	REF	reference		
	3	a	anode		
 SOT753 Pinning	1	NC	no internal connection		REF a —  — k
	2	NC	no internal connection		
	3	k	cathode		
	4	REF	reference		
	5	a	anode		

Key benefits

- ▶ Enabling regulated voltage down to 1.24 V
- ▶ Any higher output voltage up to 18 V can be set by just two external resistors
- ▶ Supports feedback loop application for 3.3 V SMPS
- ▶ Lowest I_k(min) value of 55 μA (typical) for improved energy efficiency
- ▶ Full temperature range from -40 to 125 °C
- ▶ Very low temperature drift: typically 4 mV (between -40 and 125 °C)
- ▶ Low output noise
- ▶ High quality level according AEC-Q100

Key applications

- ▶ Shunt voltage regulator
- ▶ Precision current limiter
- ▶ Precision constant current sink
- ▶ Isolated feedback loop for Switch Mode Power Supply (SMPS)

Feedback loop application

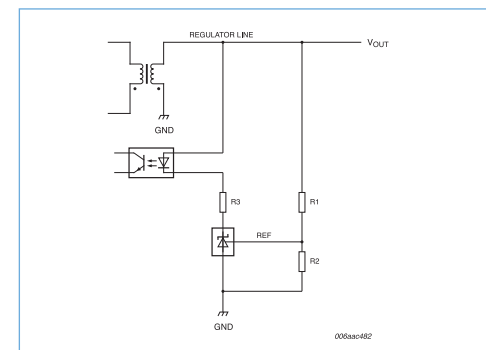

Package dimensions and footprints

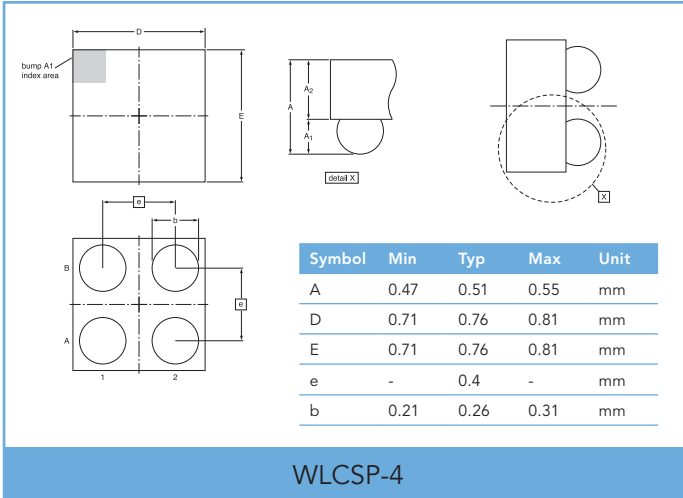

WLCSP-4

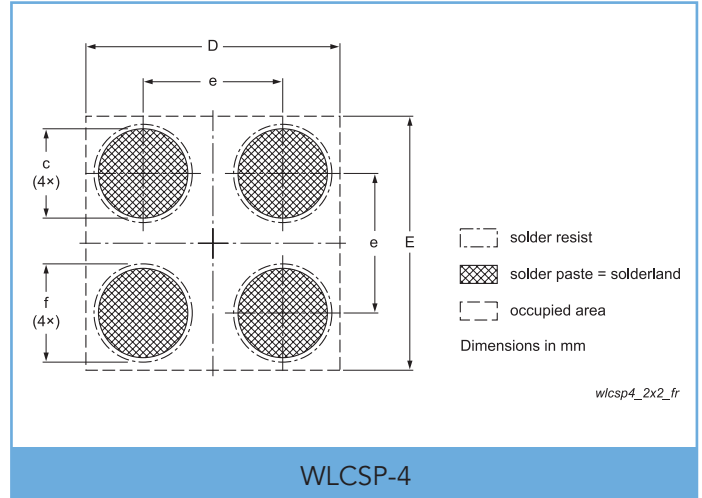

WLCSP-4

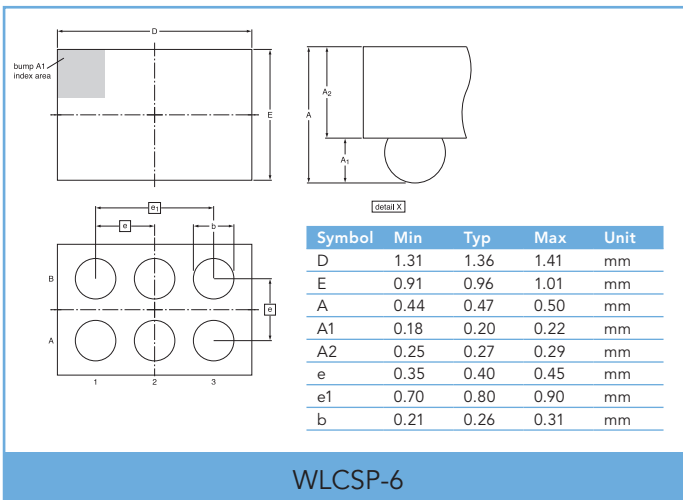

WLCSP-6

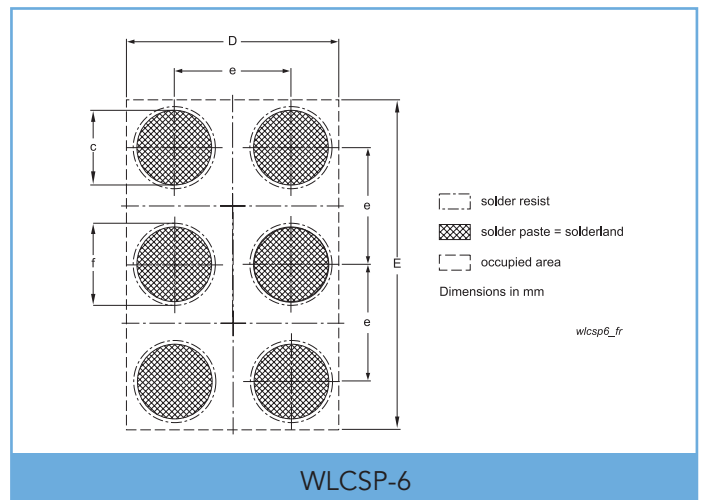

WLCSP-6

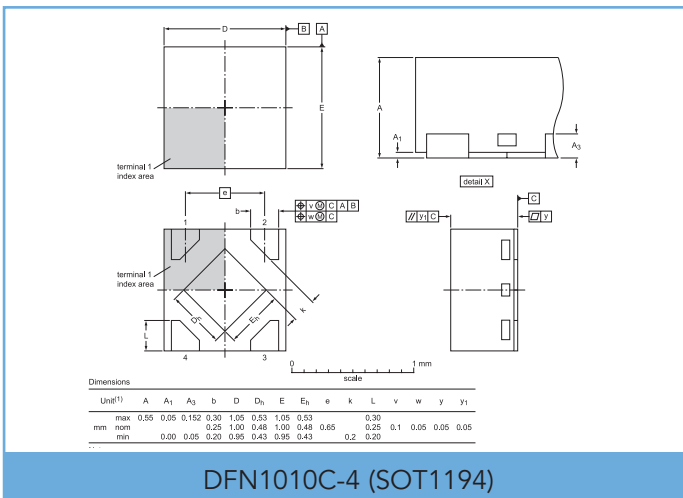

DFN1010C-4 (SOT1194)

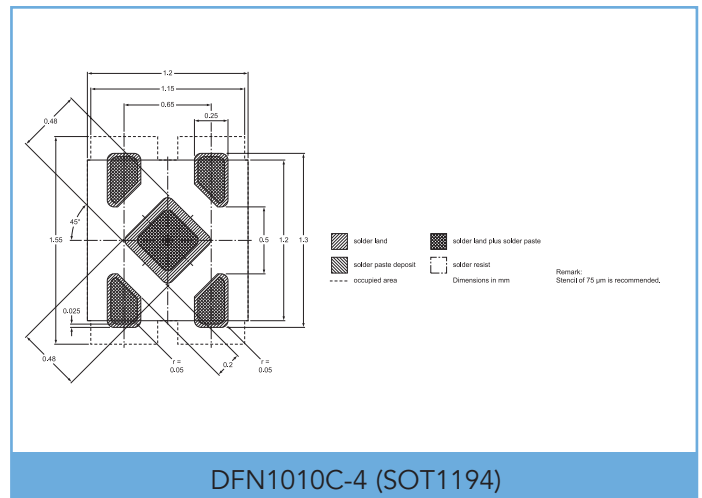

Package dimensions and footprints

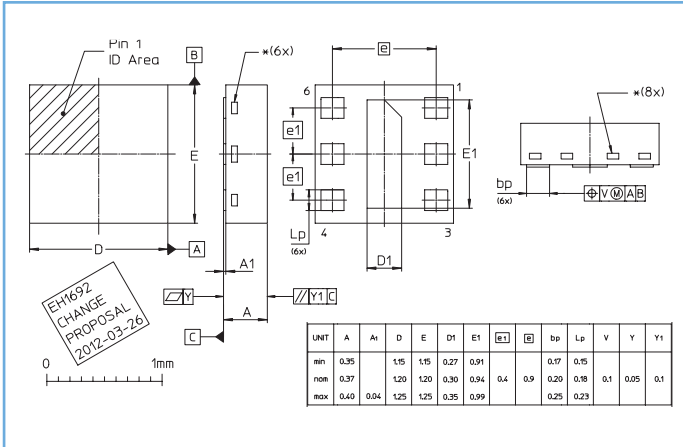

DFN1212-6 (SOT1229)

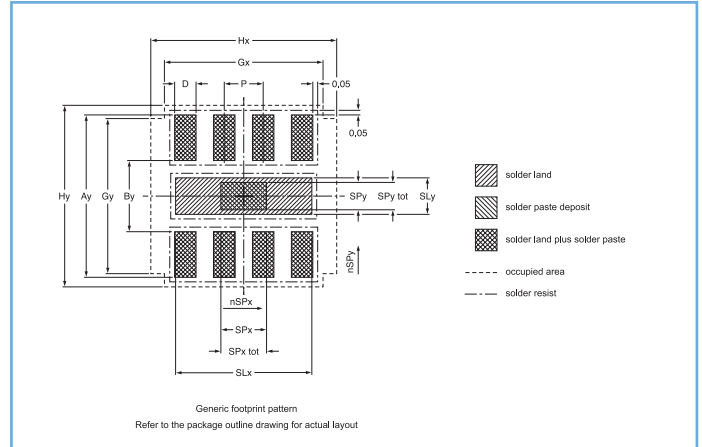

DFN1212-6 (SOT1229)

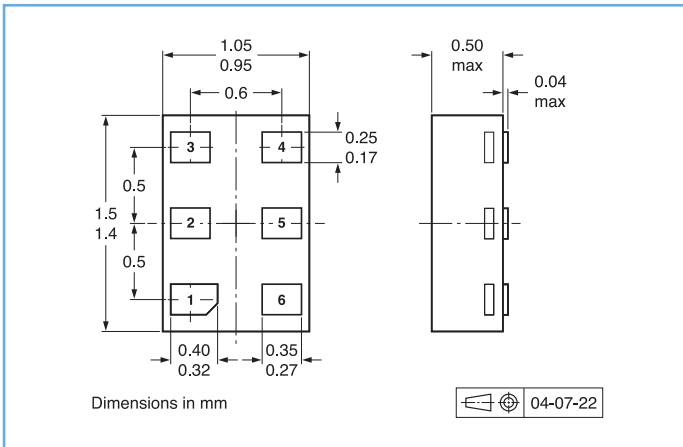

DFN1410-6 (SOT886)

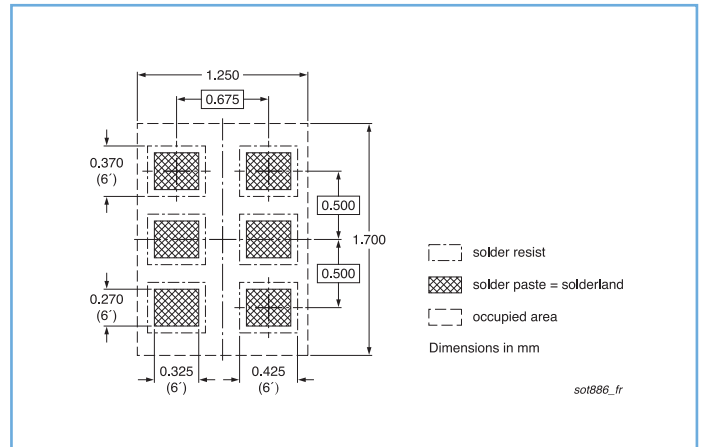

DFN1410-6 (SOT886)

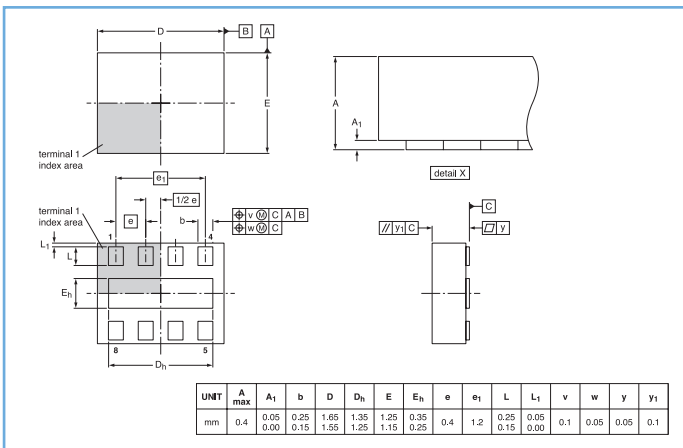

DFN1612-8 (SOT1225)

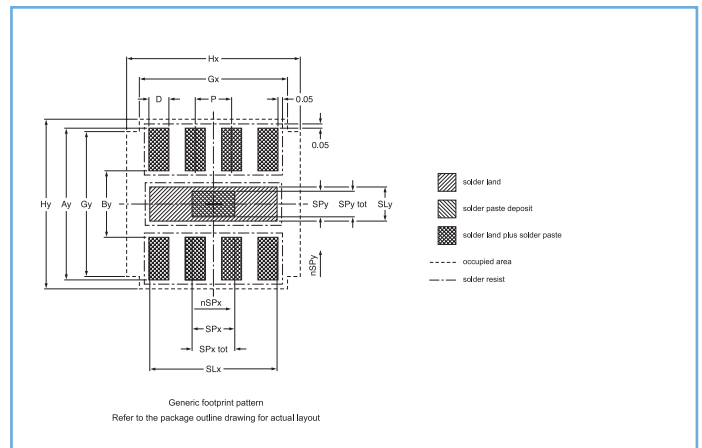

DFN1612-8 (SOT1225)

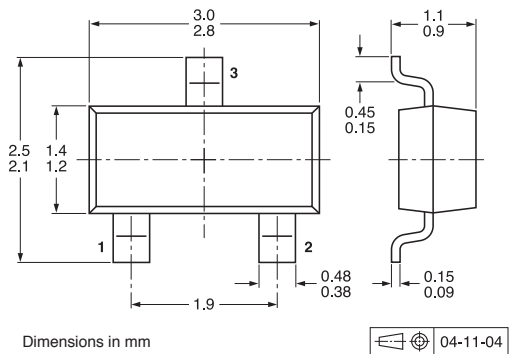

SOT23

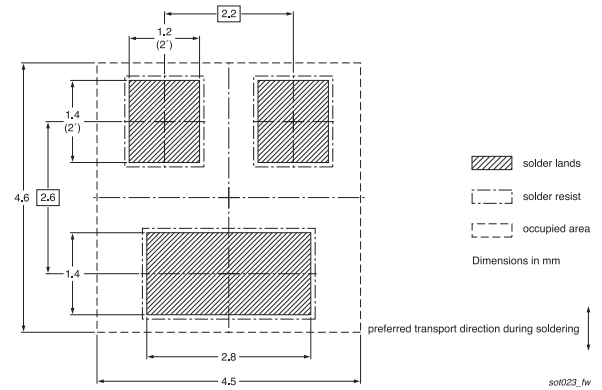

SOT23

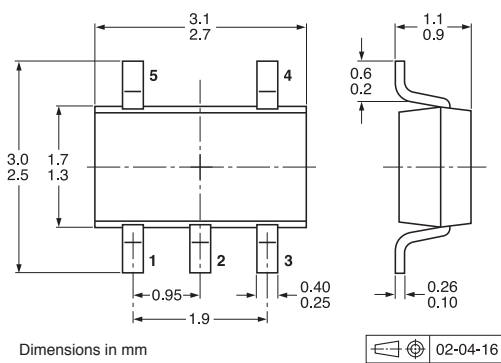

SOT753 (SOT23-5)

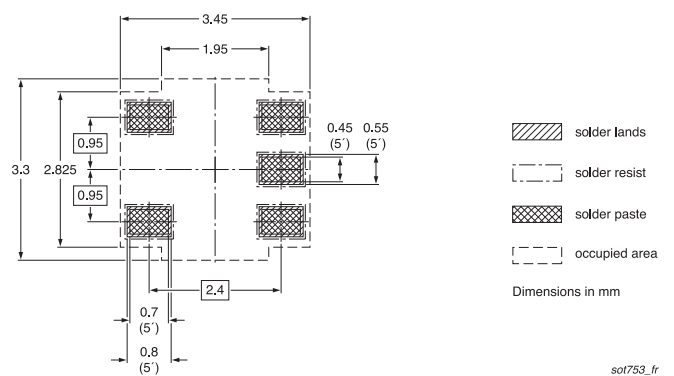

SOT753 (SOT23-5)

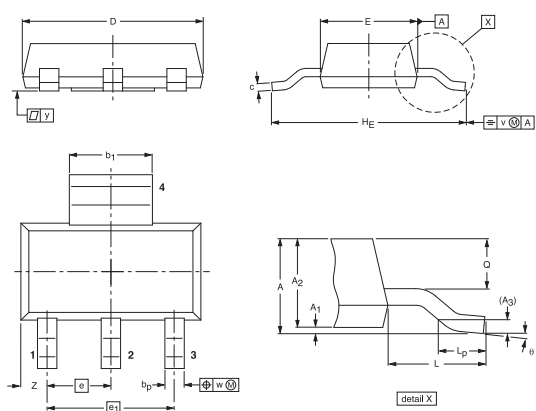

SOT223

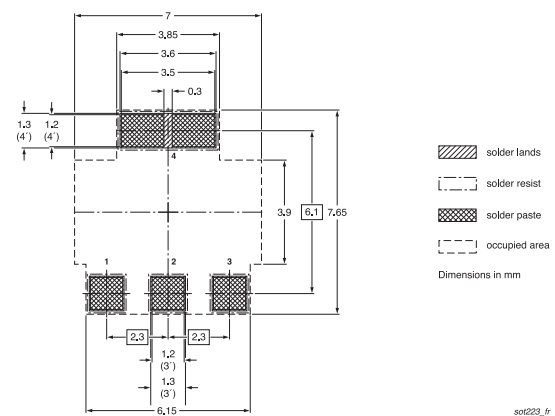

SOT223

NXP Standard Linear, nice to meet you!

- Worldwide office representations
- Large and experienced development team
- Standard Linear headquarter in Hamburg/Germany

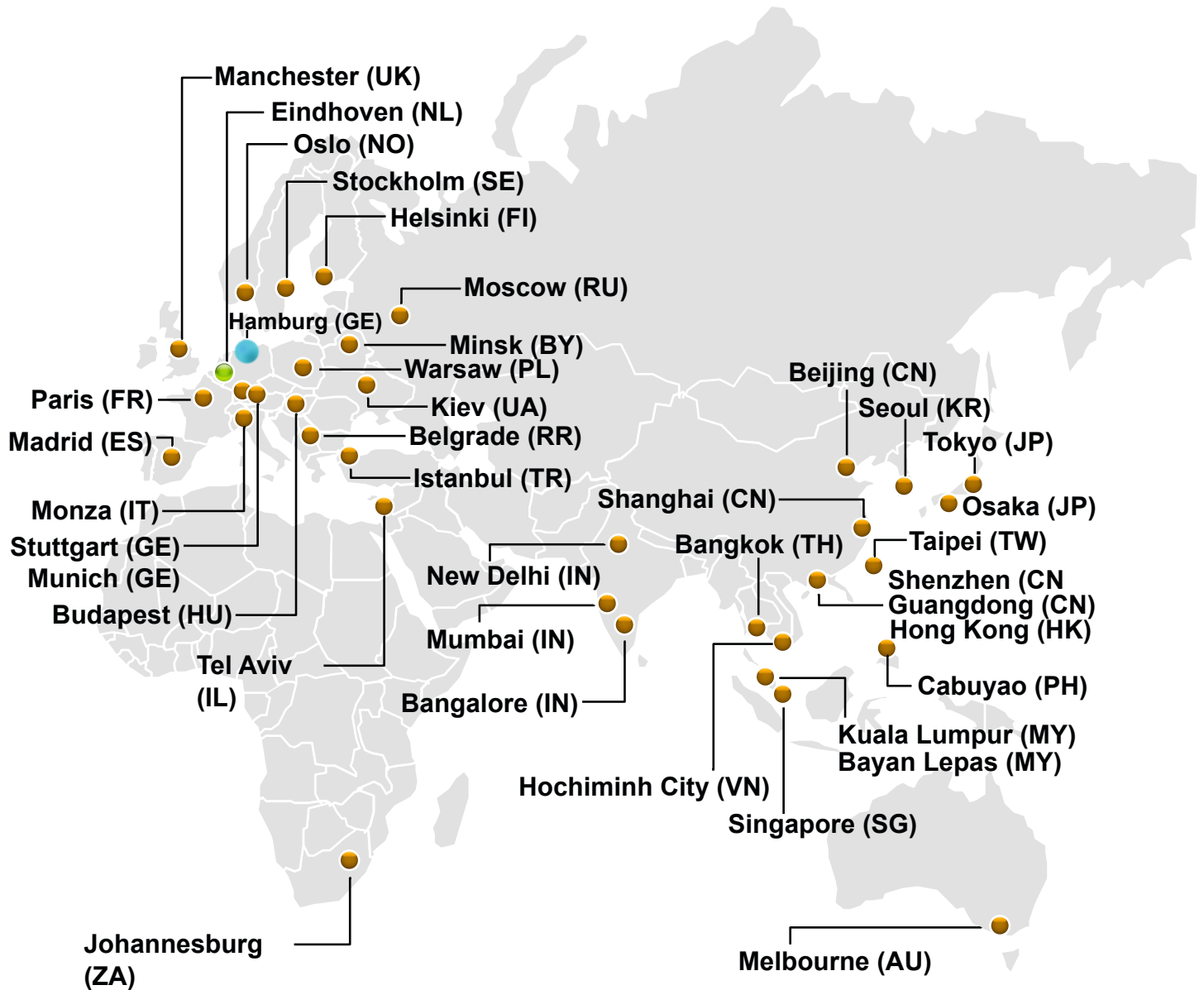

We can meet your demand!

- Large in-house capacities for front- and back-end
- Competitive manufacturing base
- Several production sites

Our products for your application!

- Low-voltage low-dropout regulator
- Shunt regulator
- Mid-voltage low-dropout regulator
- Active products
- DC/DC converter - switching regulator

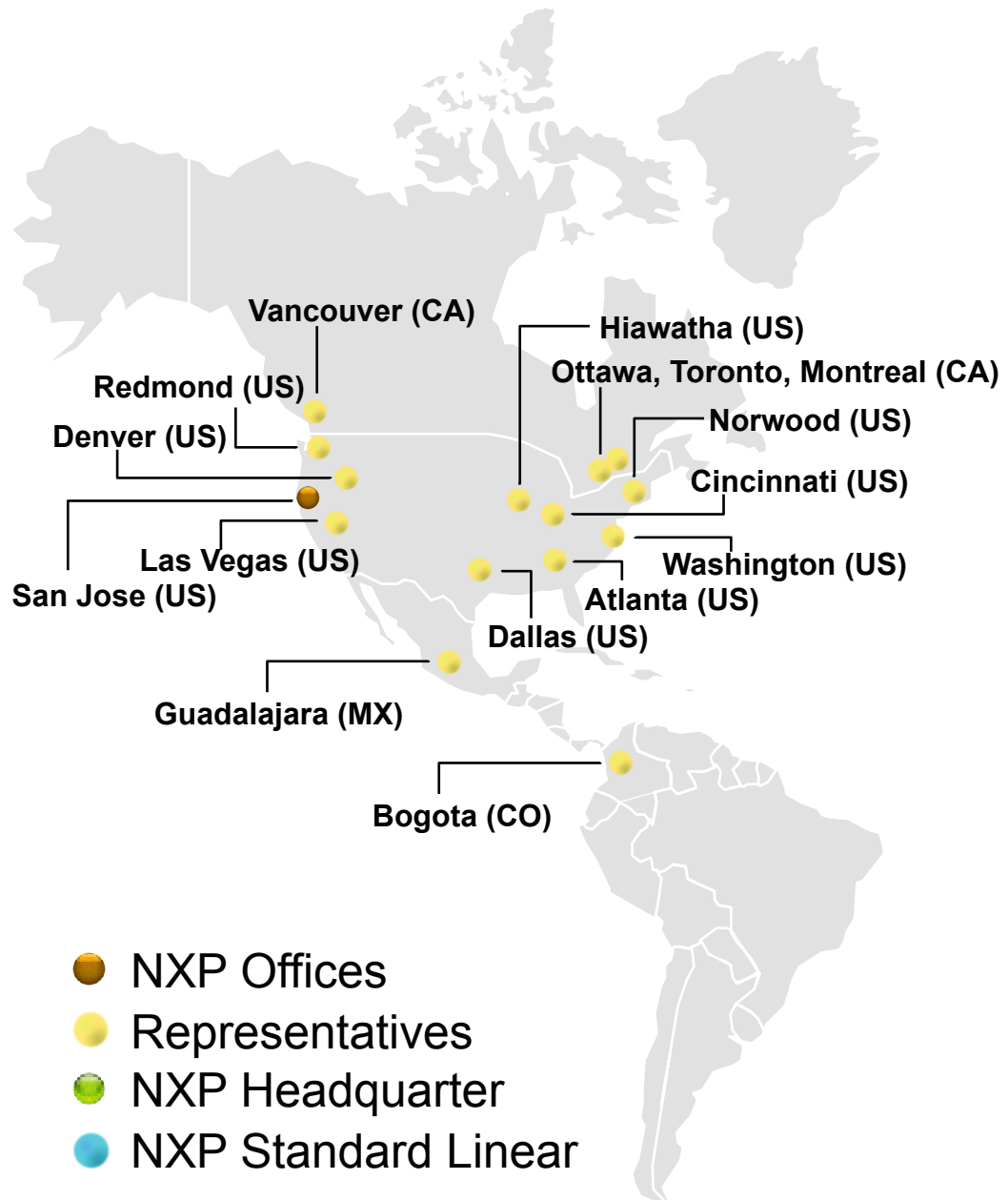

We supply high quality to you!

- Safe-Launch (DFX) for low CPB (complaints per billion)
- AECQ100 released products
- Zero-Defect Program
- Six Sigma Program
- Green Products, ...



www.nxp.com

© 2012 NXP Semiconductors N.V.

All rights reserved. Reproduction in whole or in part is prohibited without the prior written consent of the copyright owner. The information presented in this document does not form part of any quotation or contract, is believed to be accurate and reliable and may be changed without notice. No liability will be accepted by the publisher for any consequence of its use. Publication thereof does not convey nor imply any license under patent- or other industrial or intellectual property rights.

Date of release: October 2012

Document order number: 9397 750 17338

Printed in the Netherlands