

DISPLAYTRONIC

XIAMEN ZETTLER ELECTRONICS CO., LTD.

SPECIFICATIONS FOR LIQUID CRYSTAL DISPLAY

AGM1232G SERIES GRAPHIC MODULE VER1.1

CUSTOMER APPROVAL			
※ PART NO. : _____			
APPROVAL		COMPANY CHOP	
CUSTOMER COMMENTS			

DISPLAYTRONIC ENGINEERING APPROVAL		
DESIGN BY	CHECKED BY	APPROVED BY

REVISION RECORD

AGM1232G SERIES GRAPHIC MODULE VER1.1

REVISION	REVISION DATE	PAGE	CONTENTS
VER1.1	15/6-2006		MODIFY THE COVER,ADD CONTENT AND REVISION RECORD.

※ CONTENTS

- 1.0 MECHANICAL DIAGRAM
- 2.0 MECHANICAL SPECS
- 3.0 ABSOLUTE MAXIMUM RATINGS
- 4.0 ELECTRICAL CHARACTERISTICS
- 5.0 OPTICAL CHARACTERISTICS
- 6.0 BLOCK DIAGRAM
- 7.0 PIN ASSIGNMENT
- 8.0 POWER SUPPLY
- 9.0 TIMING CHARACTERISTICS
- 10.0 RELIABILITY TEST
- 10.0 RELATION BETWEEN DISPLAY PATTERN AND DRIVERS
- 12.0 DISPLAY CONTROL INSTRUCTION
- 13.0 PRECAUTION FOR USING LCM

1.0 MECHANICAL DIAGRAM

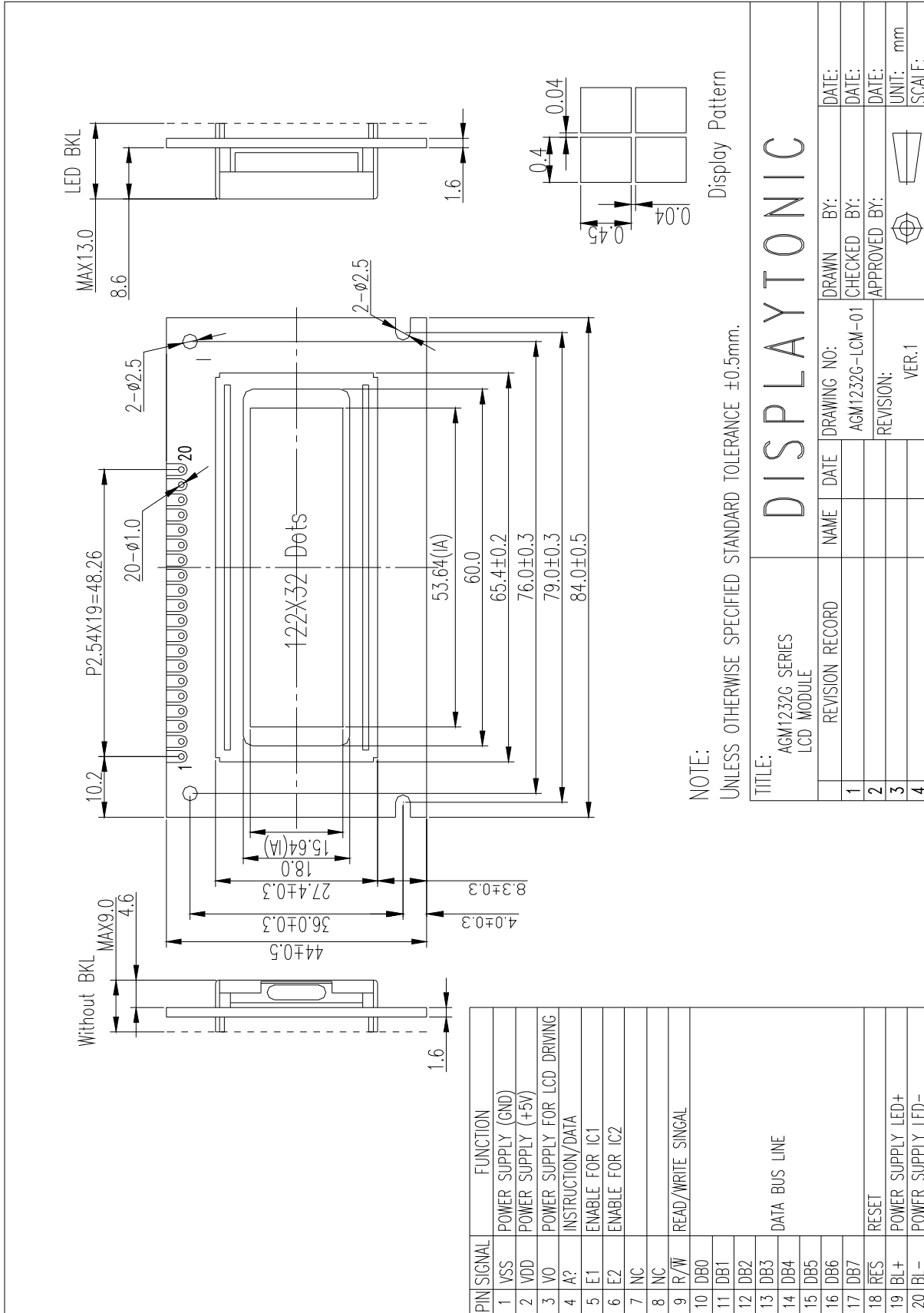

2.0 MECHANICAL SPECS

Item	Description
1. Overall Module Size	84.0mm(W) x 44.0mm(H) x max 13.0mm(D) for LED backlight version 84.0mm(W) x 44.0mm(H) x max 9.0mm(D) for reflective version
2. View Size	60.0mm(W) x 18.0mm(H)
3. Dot Size	0.40mm(W) x 0.45mm(H)
4. Dot Pitch	0.44mm(W) x 0.49mm(H)
5. Duty	1/32
6. Controller IC	PT6520 OR EQUI
7. LC Fluid Options	STN, FSTN
8. Polarizer Options	Reflective, Transflective, Transmissive
9. Backlight Options	LED
10. Temperature Range Options	Standard (0°C ~ 50°C), Wide (-20°C ~ 70°C)

3.0 ABSOLUTE MAXIMUM RATINGS

Item	Symbol	Min	Typ	Max	Unit
Operating temperature (Standard)	Top	0	-	50	°C
Storage temperature (Standard)	Tst	-10	-	60	°C
Operating temperature (Wide temperature)	Top	-20	-	70	°C
Storage temperature (Wide temperature)	Tst	-30	-	80	°C
Input voltage	Vin	Vss		Vdd	V
Supply voltage for logic	Vdd- Vss	-0.3	-	7.0	V
Supply voltage for LCD drive	Vdd- Vo	3.5	6.5	13.0	V

4.0 ELECTRICAL CHARACTERISTICS

Item	Symbol	Condition	Min	Typ	Max	Unit
Input voltage (high)	Vih	H level	3.5	-	Vdd	V
Input voltage (low)	Vil	L level	0	-	1.5	V
Recommended LC Driving Voltage	Vdd - Vo	-20°C	-		9.5	V
		25°C	-	6.5	-	
		70°C	4.5		-	
Power Supply Current	Idd	Vdd=5.0V	-	-	13.0	mA
LED Power Supply Voltage	VBL+	R8=6.8Ω	-	5.0		V
LED Power Supply Current	Iflcd	R8=6.8Ω	-	120	160	mA

5.0 OPTICAL CHARACTERISTICS

Item Mode		Cr (Contrast Ratio)		θ (Viewing Angle)		ϕ (Viewing Angle)	
		25°C		25°C		25°C	
		MIN.	TYP.	MIN	TYP.	MIN	TYP.
R	A	2.8	3.05	80°	85°	-	35°
	B	7.10	7.70	80°	85°	-	35°
	C	7.15	7.80	80°	85°	-	-
S	A	2.49	2.99	80°	85°	-	35°
	B	7.05	7.55	80°	85°	-	35°
	C	7.10-	7.65-	80°	85°	-	-

Note:

R: Reflective
 S: Transflective
 A: STN Gray
 B: STN Yellow
 C: FSTN

At: $\phi = 0^\circ$, $\theta = 0^\circ$

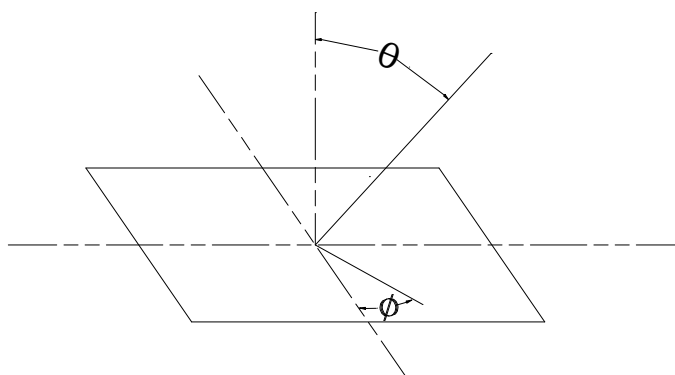

Item	Symbol	Condition	Min	Typ	Max	Unit
Response time (rise)	Tr	25 °C	-	80	160	ms
Response time (fall)	Tf	25°C	-	50	100	ns

6.0 BLOCK DIAGRAM

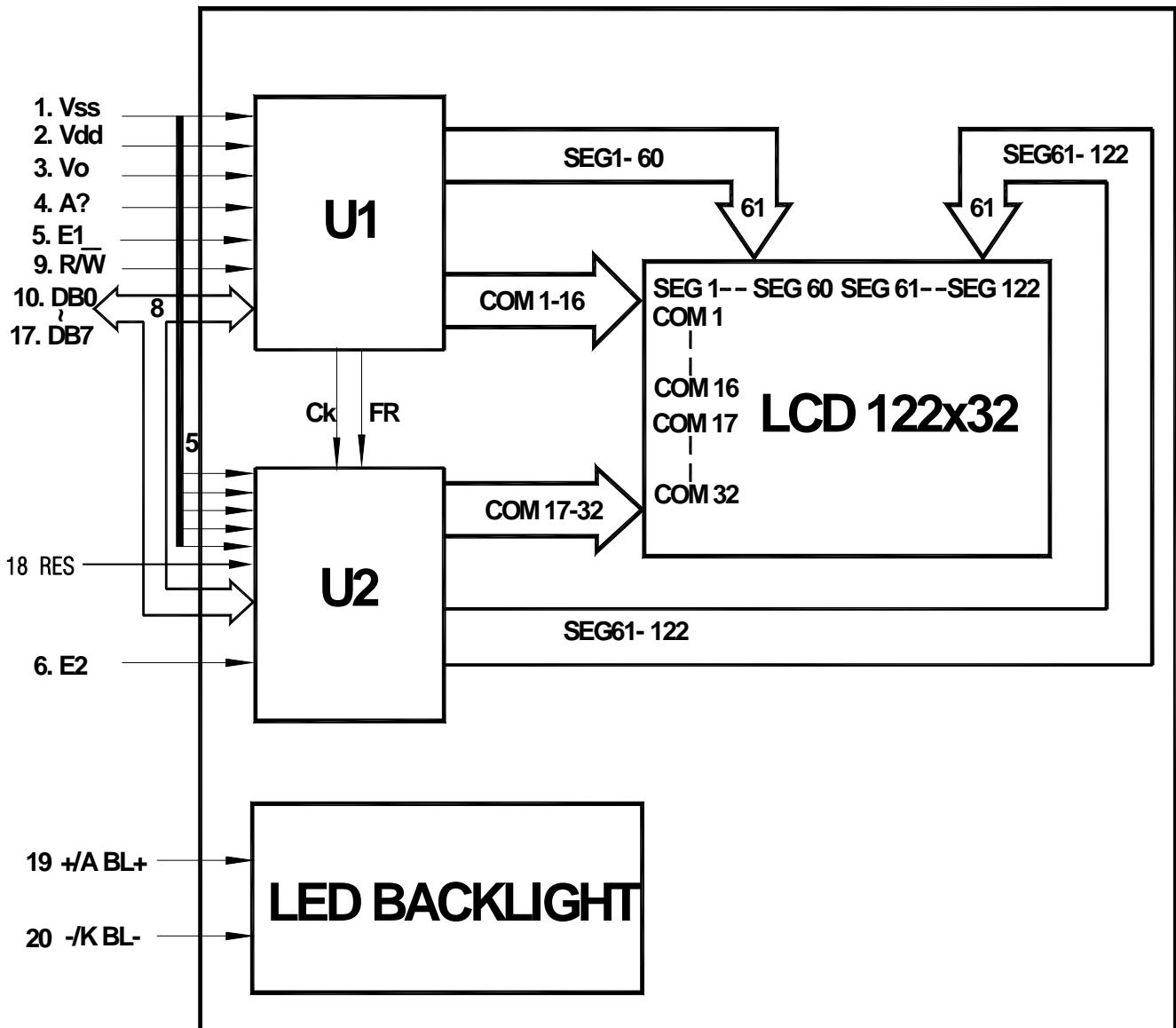

7.0 PIN ASSIGNMENT

Pin No.	Symbol	Function	Level
1	Vss	Ground	-
2	Vdd	Power Supply For Logic Circuit	-
3	Vo	Power Supply For LCD Driving	-
4	AØ	Instruction/Data	H/L
5	E1	Enable for IC1	H/L
6	E2	Enable for IC2	H/L
7	NC		
8	NC		
9	R/W	H: Data read L: Data write	H/L
10	DB0	Data bit 0	H/L
11	DB1	Data bit 1	H/L
12	DB2	Data bit 2	H/L
13	DB3	Data bit 3	H/L
14	DB4	Data bit 4	H/L
15	DB5	Data bit 5	H/L
16	DB6	Data bit 6	H/L
17	DB7	Data bit 7	H/L
18	RST (NC)	Reset	
19	BL+	Power Supply for BL+(5.0V)	-
20	BL-	Power Supply for BL-	-

8.0 POWER SUPPLY

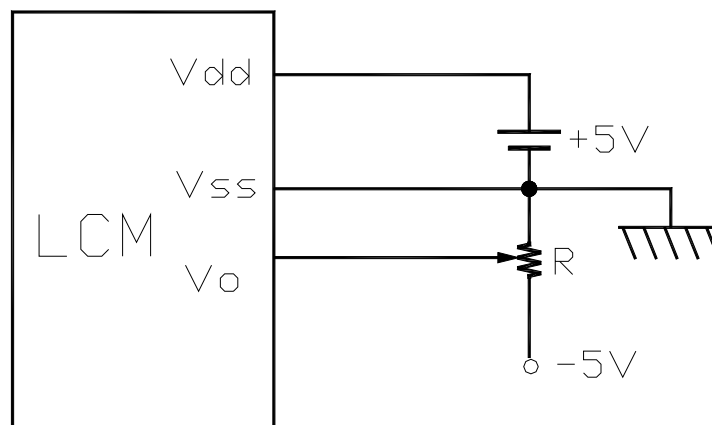

9.0 TIMING CHARACTERISTICS

Item	Symbol	Test Condition	Min.	Typ.	Max.	Unit
System cycle time	t_{CYC6}	Fig. a, Fig. b	1000	-	-	ns
Address setup time	t_{AW6}	Fig. a, Fig. b	20	-	-	ns
Address hold time	t_{AH6}	Fig. a, Fig. b	10	-	-	ns
Data hold time	t_{DH6}	Fig. a	10	-	-	ns
Data setup time	t_{DS6}	Fig. a	80	-	-	ns
Output disable time	t_{OH6}	CL=100 pF	10	-	60	ns
Access time	t_{ACC6}		-	-	90	
Enable pulsewidth	Read Write	T_{EW}	100			
			80			
Rise and fall time	T_r, T_f	Fig. a, Fig. b	-	-	15	ns

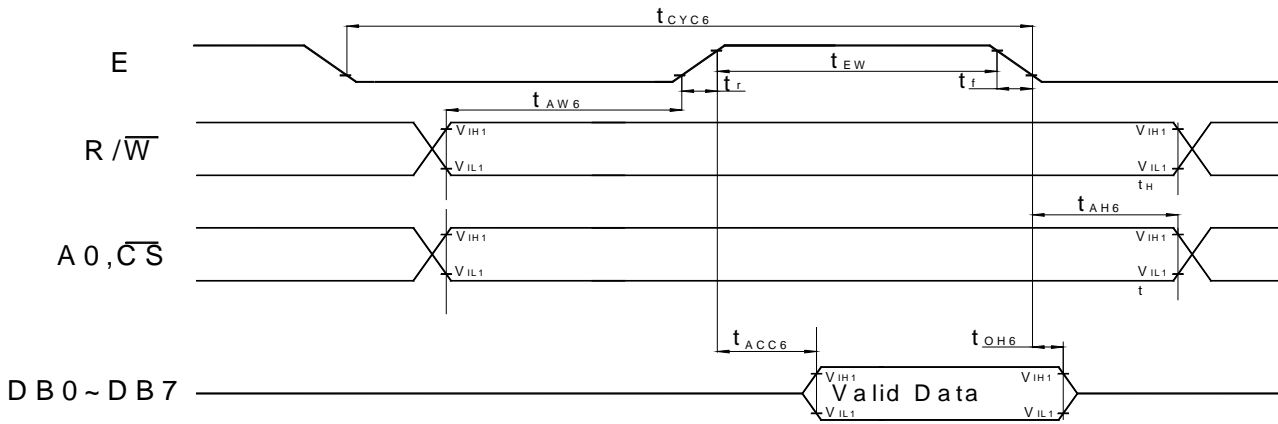

Fig. a Interface timing (data Read)

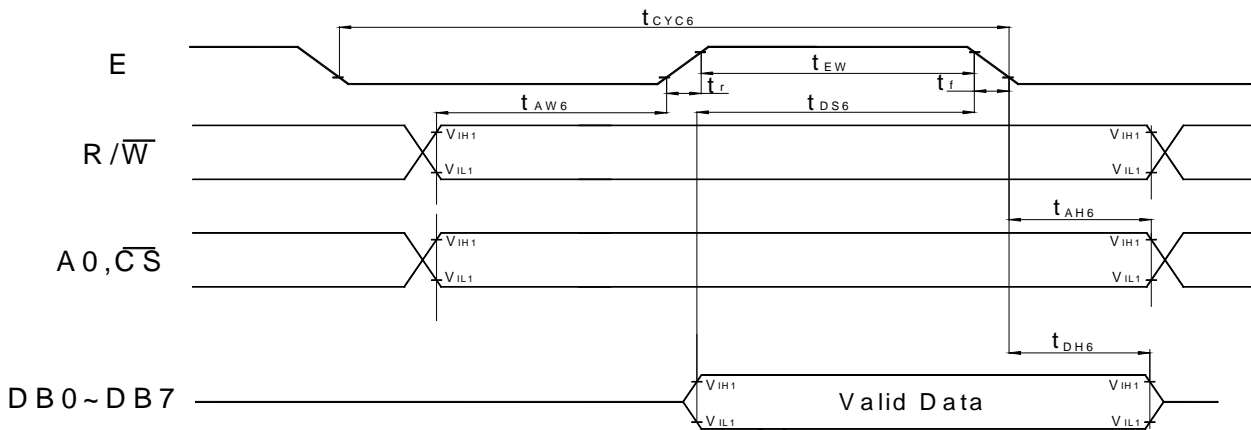

Fig. b Interface timing (data Write)

10.0 RELIABILITY TEST

Storage Condition	Content	Evaluations and Assessment*			
		Current Consumption	Oozing	Contrast	Other Appearances
Operation at high temperature and humidity	40°C,90% RH,240hrs	Twice initial value or less	none	More than 80% of initial value	No abnormality
High temperature storage	60°C, 240hrs	Twice initial value or less	none	More than 80% of initial value	No abnormality
Low temperature storage	-20°C, 240hrs	Twice initial value or less		More than 80% of initial value	No abnormality

*Evaluations and assessment to be made two hours after returning to room temperature (25°C±5°C).

*The LCDs subjected to the test must not have dew condensation.

11.0 RELATION BETWEEN DISPLAY PATTERN AND DRIVERS

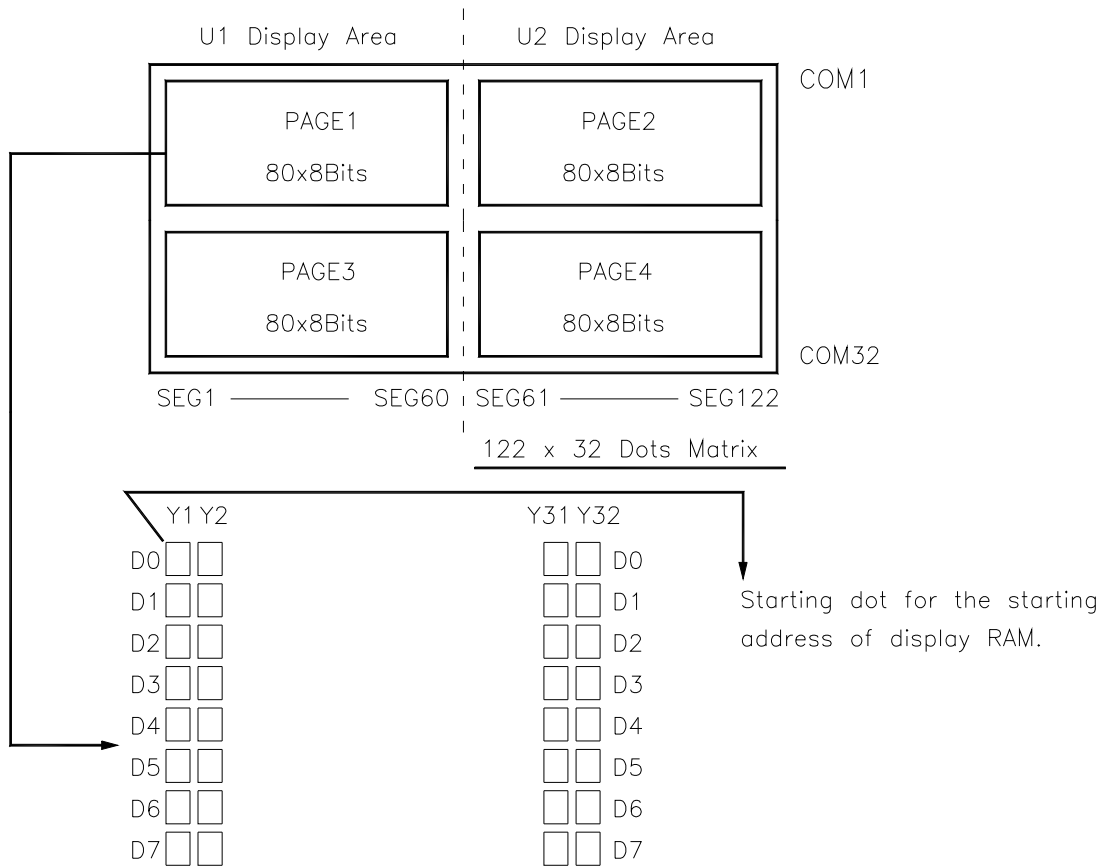

Each segment driver has 4 pages RAM, and each page has 80x8 bits RAM.
 D0~D7 are 8 bits transmitted data, where D0 is LSB and D7 is MSB.

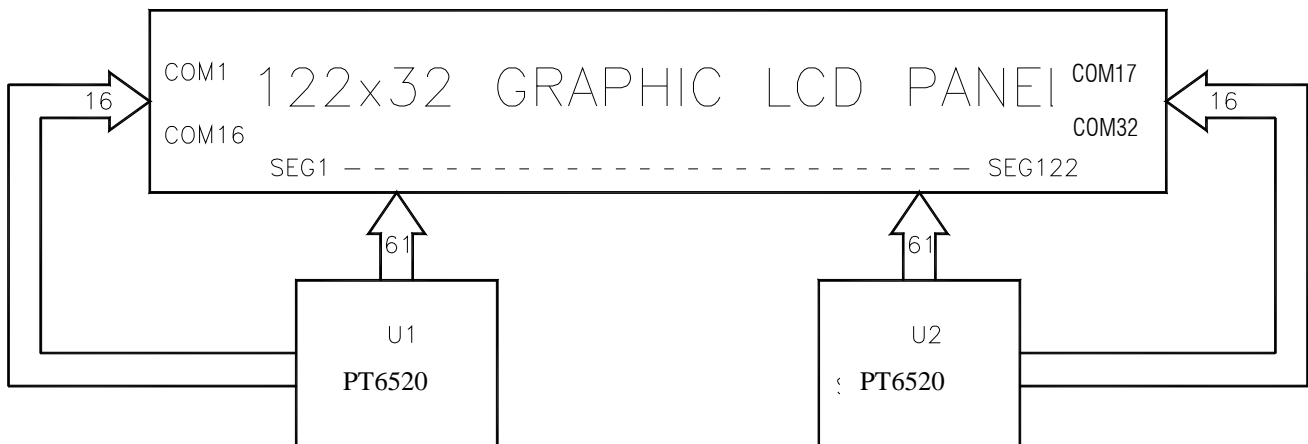

12.0 DISPLAY CONTROL INSTRUCTION

The display control instructions control the internal state of the PT6520. Instructions are received from MPU to PT6520 for the display control.

INSTRUCTION	A0	RD	R/W	DB7	DB6	DB5	DB4	DB3	DB2	DB1	DB0	DESCRIPTION	
Display ON/OFF	0	1	0	1	0	1	0	1	1	1	1/0	Turns display on or off. 0: OFF. 1:ON	
Set Page Address	0	1	0	1	0	1	1	1	0	Page (0~3)		Sets display RAM Page in Page address register	
Set Column (Segment address)	0	1	0	0	Column address (0~79)							Sets display RAM column address in column address register	
Display Start Line	0	1	0	1	1	0	Display start line (0~31)					Indicates the display data RAM displayed at the top of the screen.	
Status Read	0	0	1	BUSY	ADC	ON/OFF	RESET	0	0	0	0	Reads the following status: BUSY 0: Ready 1: Busy ADC 1: CW output 0: CCW output ON/OFF 0: Display on 1: Display off RESET 0: Normal 1: Being Reset	
Write Display Data	1	1	0	Write Data									Writes data DB0~DB7 from bus into display data RAM.
Read Display Data	1	0	1	Read Data									Reads data DB0~DB7 from display data RAM onto the data bus.
Select ADC	0	1	0	1	0	1	0	0	0	0	0/1	0: CW output, 1: CCW output	
Static drive ON/OFF	0	1	0	1	0	1	0	0	1	0	0/1	1: Static drive, 0: Normal driving	
Select duty	0	1	0	1	0	1	0	1	0	0	0/1	Select LCD duty cycle 1:1/32, 0: 1/16	
Read-Modify-Wreti	0	1	0	1	1	1	0	0	0	0	0	Read-Modify-write ON	
END	0	1	0	1	1	1	0	1	1	1	0	Read-Modify-write OFF	
Reset	0	1	0	1	1	1	0	0	0	1	0	Software reset	

13.0 PRECAUTION FOR USING LCM

1. When design the product with this LCD Module, make sure the viewing angle matches to its purpose of usage.
2. As LCD panel is made of glass substrate, Dropping the LCD module or banging it against hard objects may cause cracking or fragmentation. Especially at corners and edges.
3. Although the polarizer of this LCD Module has the anti-glare coating, always be careful not to scratch its surface. Use of a plastic cover is recommended to protect the surface of polarizer.
4. If the LCD module is stored at below specified temperature, the LC material may freeze and be deteriorated. If it is stored at above specified temperature, the molecular orientation of the LC material may change to Liquid state and it may not revert to its original state. Excessive temperature and humidity could cause polarizer peel off or bubble. Therefore, the LCD module should always be stored within specified temperature range.
5. Saliva or water droplets must be wiped off immediately as those may leave stains or cause color changes if remained for a long time. Water vapor will cause corrosion of ITO electrodes.
6. If the surface of LCD panel needs to be cleaned, wipe it swiftly with cotton or other soft cloth. If it is not still clean enough, blow a breath on the surface and wipe again.
7. The module should be driven according to the specified ratings to avoid malfunction and permanent damage. Applying DC voltage cause a rapid deterioration of LC material. Make sure to apply alternating waveform by continuous application of the M signal. Especially the power ON/OFF sequence should be kept to avoid latch-up of driver LSIs and DC charge up to LCD panel.
8. Mechanical Considerations
 - a) LCM are assembled and adjusted with a high degree of precision. Avoid excessive shocks and do not make any alterations or modifications. The following should be noted.
 - b) Do not tamper in any way with the tabs on the metal frame.
 - c) Do not modify the PCB by drilling extra holes, changing its outline, moving its components or modifying its pattern.
 - d) Do not touch the elastomer connector; especially insert a backlight panel (for example, EL).
 - e) When mounting a LCM makes sure that the PCB is not under any stress such as bending or twisting. Elastomer contacts are very delicate and missing pixels could result from slight dislocation of any of the elements.
 - f) Avoid pressing on the metal bezel, otherwise the elastomer connector could be deformed and lose contact, resulting in missing pixels.
9. Static Electricity
 - a) Operator

Wear the electrostatics shielded clothes because human body may be statically charged if not wear shielded clothes. Never touch any of the conductive parts such as the LSI pads; the copper leads on the PCB and the interface terminals with any parts of the human body.

b) Equipment

There is a possibility that the static electricity is charged to the equipment, which has a function of peeling or friction action (ex: conveyer, soldering iron, working table). Earth the equipment through proper resistance (electrostatic earth: 1×10^8 ohm).

Only properly grounded soldering irons should be used.

If an electric screwdriver is used, it should be well grounded and shielded from commutator sparks.

The normal static prevention measures should be observed for work clothes and working benches; for the latter conductive (rubber) mat is recommended.

c) Floor

Floor is the important part to drain static electricity, which is generated by operators or equipment.

There is a possibility that charged static electricity is not properly drained in case of insulating floor. Set the electrostatic earth (electrostatic earth: 1×10^8 ohm).

d) Humidity

Proper humidity helps in reducing the chance of generating electrostatic charges. Humidity should be kept over 50%RH.

e) Transportation/storage

The storage materials also need to be anti-static treated because there is a possibility that the human body or storage materials such as containers may be statically charged by friction or peeling.

The modules should be kept in antistatic bags or other containers resistant to static for storage.

f) Soldering

AGM1232G SERIES GRAPHIC MODULE VER1.1

Solder only to the I/O terminals. Use only soldering irons with proper grounding and no leakage.

Soldering temperature : $280^{\circ}\text{C} \pm 10^{\circ}\text{C}$

Soldering time: 3 to 4 sec.

Use eutectic solder with resin flux fill.

If flux is used, the LCD surface should be covered to avoid flux spatters. Flux residue should be removed afterwards.

g) Others

The laminator (protective film) is attached on the surface of LCD panel to prevent it from scratches or stains. It should be peeled off slowly using static eliminator.

Static eliminator should also be installed to the workbench to prevent LCD module from static charge.

10. Operation

- a) Driving voltage should be kept within specified range; excess voltage shortens display life.
 - b) Response time increases with decrease in temperature.
 - c) Display may turn black or dark blue at temperatures above its operational range; this is (however not pressing on the viewing area) may cause the segments to appear "fractured".
 - d) Mechanical disturbance during operation (such as pressing on the viewing area) may cause the segments to appear "fractured".
11. If any fluid leaks out of a damaged glass cell, wash off any human part that comes into contact with soap and water. The toxicity is extremely low but caution should be exercised at all the time.
 12. Disassembling the LCD module can cause permanent damage and it should be strictly avoided.
 13. LCD retains the display pattern when it is applied for long time (Image retention). To prevent image retention, do not apply the fixed pattern for a long time. Image retention is not a deterioration of LCD. It will be removed after display pattern is changed.
 14. Do not use any materials, which emit gas from epoxy resin (hardener for amine) and silicone adhesive agent (dealcohol or deoxym) to prevent discoloration of polarizer due to gas.
 15. Avoid the exposure of the module to the direct sunlight or strong ultraviolet light for a long time.
 16. The brightness of LCD module may be affected by the routing of CCFL cables due to leakage to the chassis through coupling effect. The inverter circuit needs to be designed taking the level of leakage current into consideration. Thorough evaluation is needed for LCD module and inverter built into its host equipment to ensure specified b