

Ambient Light Sensor and Proximity Sensor with I²C Interface APS-16D25-11-DF8/TR8

Features

Ambient light sensing

- Maximum detectable illumination up to 57671Lux
- Maximum resolution 0.01375Lux/count
- Human eye type spectral response (IR rejection)
- 16-bit effective resolution
- Provides an output count proportional to ambient light over the full operating range

Proximity sensing

- IR LED driver current can be selected between 100mA and 200mA
- 8-bit effective resolution
- Storage temperature range from -40°C to 85°C
- Operating temperature range from -40°C to 85°C
- Operating voltage range: 2.5V ~ 3.6V
- Size: 2.1mm (L) x 2.0mm (W) x 0.6mm (H)
- RoHS compliant and Pb Free package

Description

The APS-16D25-11-DF8/TR8 is a digital-output ambient light sensor with built-in IR driver and I²C interface. The APS-16D25-11-DF8/TR8 has signal processing circuit on a CMOS integrated circuit to provide light measurements over an effective 16bit dynamic range with a response similar to that of human eye. The APS-16D25-11-DF8/TR8 uses user-selected modulation frequency to drive the external IR LED and employ a noise cancellation scheme to highly reject unwanted IR noise. The APS-16D25-11-DF8/TR8 has excellent temperature compensation, robust refresh rate setting without any external RC low-pass filter. Connected with an infrared LED (IR-LED), the built-in proximity sensor can reveal the closeness of approaching/departing objects. This device is intended primarily for use in applications in which measurement of ambient light and proximity sensing is a necessary, such as laptop computers, PDA, camcorders, mobile phone, smart phone.

Applications

- Detection of ambient light for controlling the backlighting of TFT LCD display
- Automatic residential and commercial lighting management
- Automatic contrast enhancement for electronic signboard
- Mobile phone, Smart phone, PDA, Table PC.

Package Dimensions

Top View

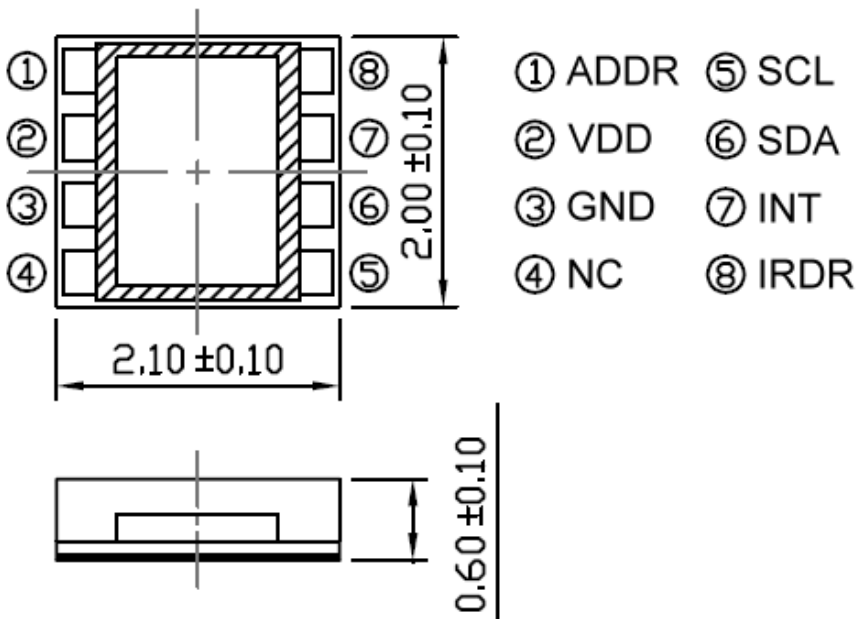

Bottom View

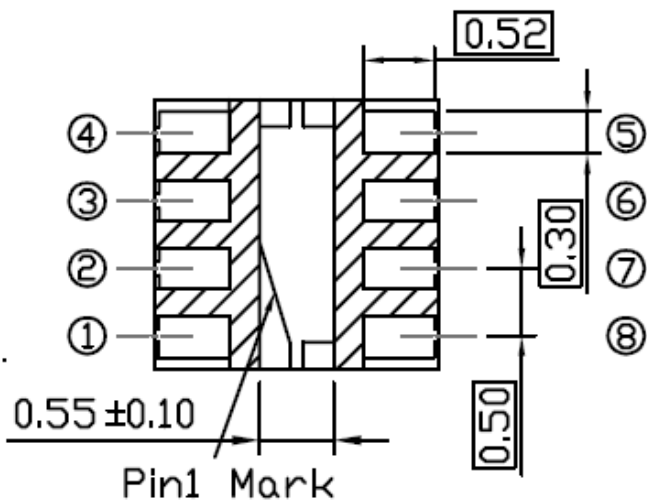

Unit: mm

Tolerances: ± 0.2 mm

PCB Soldering PAD

PCB Soldering Pad

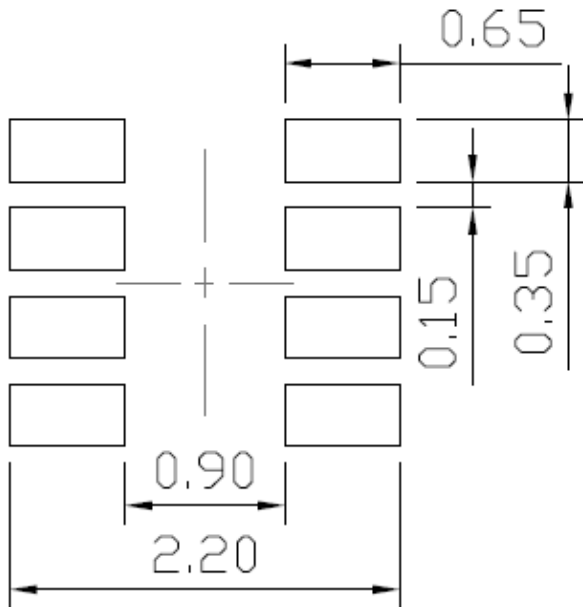

Pin Description

Pin No.	Pin name	Pin function
1	ARDR	I ² C address pin. High level: 0xB0; Low level: 0x90
2	VDD	Power supply voltage: 2.5V ~ 3.6V
3	GND	Ground: The thermal pad is also connected to the GND pin
4	NC	No connected
5	SCL	I ² C serial clock line
6	SDA	I ² C serial data line
7	INT	Interrupt pin: LO for interrupt alarming. The INT pin is an open drain
8	IRDR	IR-LED driver pin connecting to the cathode of the external IR-LED. The source current of the IR-LED driver can be programmed through I ² C

Block Diagram

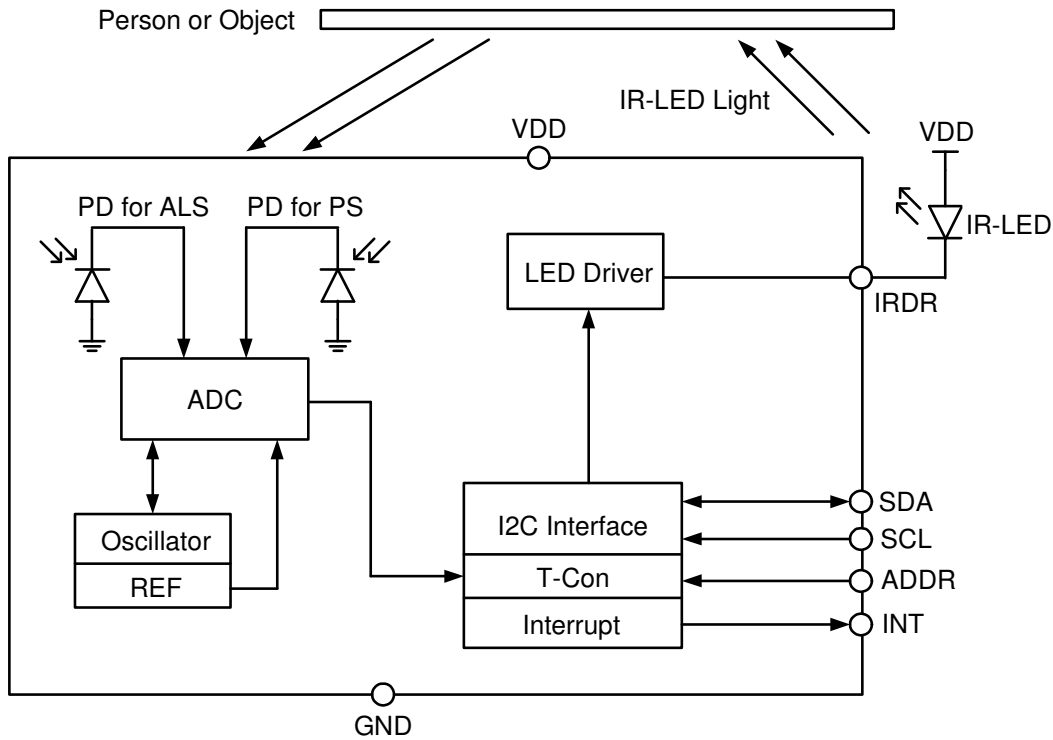

Figure 1. APS-16D25-11-DF8/TR8 Block Diagram

Typical Application Circuit

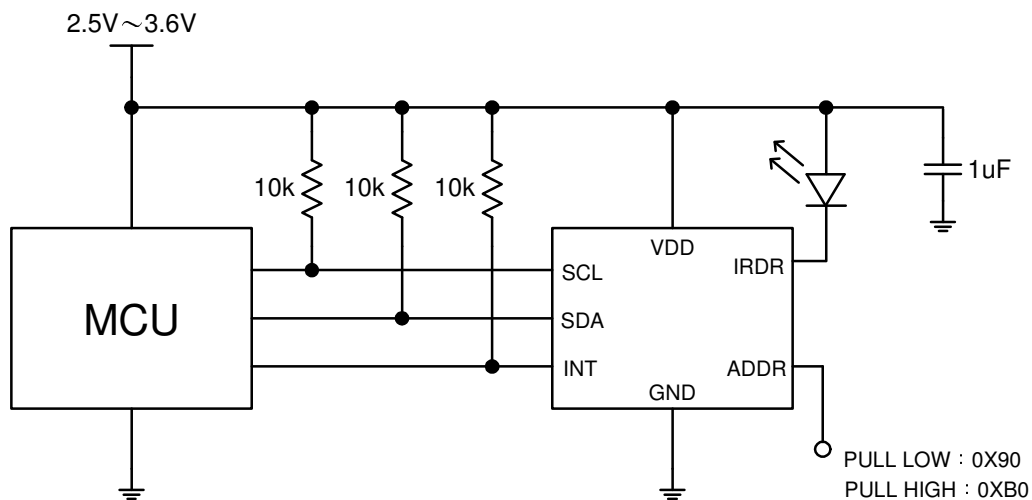

Figure 2. APS-16D25-11-DF8/TR8 Typical Application Circuit

Absolute Maximum Ratings

Parameter	Symbol	Min.	Typ.	Max.	Unit
Supply voltage	V _{DD}	-0.3	-	5.5	V
Operation temperature	T _a	-40	-	85	°C
Storage temperature	T _s	-40	-	85	°C

Recommended Operating Conditions

Parameter	Symbol	Min.	Typ.	Max.	Unit
Supply voltage	V _{DD}	2.5	2.8	3.6	V
Clock frequency of I ² C	f _{I2C}	-	-	400	kHz
Operation temperature	T _a	-40	-	85	°C

Electrical and Optical Characteristics (T_a=25°C , V_{op}=3.3 V)

Parameter	SYB	Test Conditions	Min.	Typ.	Max.	Unit
Supply current	I _{DD}	Note 1		90		μA
Shutdown current	I _{SD}	Note 2		1		μA
Full scale ADC code for ALS	ALS_FS	16-bit effective resolution			65535	Counts
Dark output count for ALS	ALS_0	E=0Lux			3	Counts
ALS count output with 0.11Lux/count	ALS_1	E=300Lux, White LED Range1(7209 Lux)	2318	2727	3136	Counts
ALS count output with 0.22Lux/count	ALS_2	E=300Lux, White LED Range2(14418 Lux)	1158	1363	1567	Counts
ALS count output with 0.44Lux/count	ALS_3	E=300Lux, White LED Range3(28836 Lux)	578	681	784	Counts
ALS count output with 0.88Lux/count	ALS_4	E=300Lux, White LED Range4(57671 Lux)	289	341	392	Counts
Full scale ADC code for PS	PS_FS	8-bit effective resolution			255	Counts
Dark output count for PS	PS_0	E=0Lux			3	Counts
PS count output	PS_1	E _e =200uW/cm ² , Note 3	85	100	115	Counts
Peak sensitivity wavelength for ALS	λ _{p1}	Note 2		550		nm
Peak sensitivity wavelength for PS	λ _{p2}	Note 2		850		nm
Logic high, I ² C	V _{IH}	Note 2	1.5		V _{DD}	V
Logic low, I ² C	V _{IL}	Note 2			0.4	V

Note:

1. Power supply (V_{DD}) is 3.3V, and 01h=0x00, 09h=0x00 without the IR-LED.
2. Power supply (V_{DD}) is 3.3V, halogen lamp light source and room temperature is 25°C.
3. The light source of IR-LED that the peak wavelength is 850nm.

Timing Chart

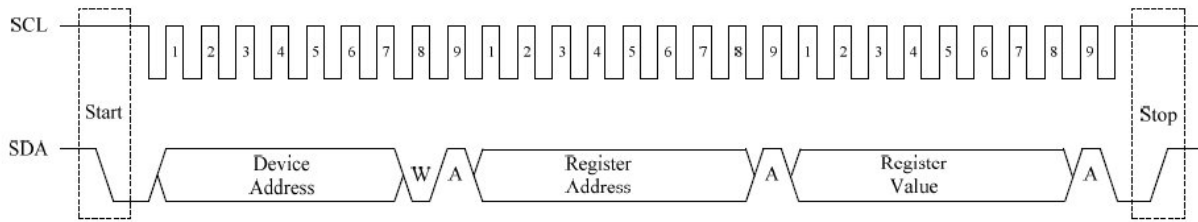

Write Command

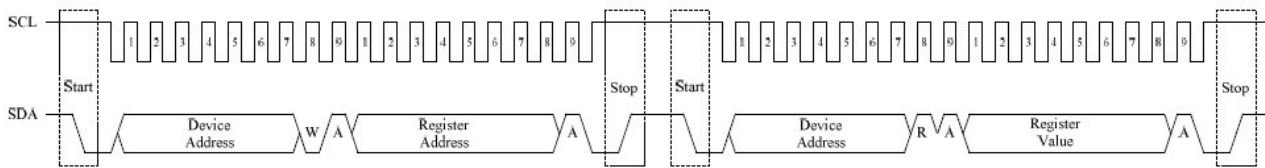

Read Data

Principle of Operation

Digital Interface

The APS-16D25-11-DF8/TR8 contains an eight 8-bit registers accessed via the I²C bus. All operations can be controlled by the command register. The sample command structure makes the user easy to program the operation setting and latch the light data from the APS-16D25-11-DF8/TR8. In timing chart, it is the APS-16D25-11-DF8/TR8 command format description for reading and writing operation between the host and the APS-16D25-11-DF8/TR8.

Slave Address

The APS-16D25-11-DF8/TR8 provides the slave address selection function for the system design convenience. The address can be defined by ADDR pin via high, and low voltage. In following table, it describes the slave address selection method and the cooperation with the command setting.

ADDR	ID Address	Command Address	Operation
PULL LOW	0x90	0x90	Write Command to APS-16D25-11-DF8/TR8
		0x91	Read Data from APS-16D25-11-DF8/TR8
PULL HIGH	0xB0	0xB0	Write Command to APS-16D25-11-DF8/TR8
		0xB1	Read Data from APS-16D25-11-DF8/TR8

Function Description

In the following table, there are 12 registers that are available in the APS-16D25-11-DF8/TR8. The APS-16D25-11-DF8/TR8 has 16-bit resolution for ALS. The host first reads the data from the 0x02 register data and then reads the 0x03 register data to complete the word mode data collection. The APS-16D25-11-DF8/TR8 has 8-bit resolution for PS. The PS data register is in the register 0x0A. The following table summarizes their function.

ADDR	REG NAME	BIT								Default
		7	6	5	4	3	2	1	0	
01h	ALS CMD	GAIN1_ ALS	GAIN0_ ALS	0	0	IT1_AL S	IT0_AL S	INT_AL S	SD_AL S	01h
02h	ALS DT1	DT15_A LS	DT14_A LS	DT13_A LS	DT12_A LS	DT11_A LS	DT10_A LS	DT9_AL S	DT8_AL S	00h
03h	ALS DT2	DT7_AL S	DT6_AL S	DT5_AL S	DT4_AL S	DT3_AL S	DT2_AL S	DT1_AL S	DT0_AL S	00h
04h	ALS THDH1	THDH1 5_ALS	THDH1 4_ALS	THDH1 3_ALS	THDH1 2_ALS	THDH1 1_ALS	THDH1 0_ALS	THDH9 _ALS	THDH8 _ALS	FFh
05h	ALS THDH2	THDH7 _ALS	THDH6 _ALS	THDH5 _ALS	THDH4 _ALS	THDH3 _ALS	THDH2 _ALS	THDH1 _ALS	THDH0 _ALS	FFh
06h	ALS THDL1	THDL1 5_ALS	THDL1 4_ALS	THDL1 3_ALS	THDL1 2_ALS	THDL1 1_ALS	THDL1 0_ALS	THDL9 _ALS	THDL8 _ALS	00h
07h	ALS THDL2	THDL7 _ALS	THDL6 _ALS	THDL5 _ALS	THDL4 _ALS	THDL3 _ALS	THDL2 _ALS	THDL1 _ALS	THDL0 _ALS	00h
08h	STA TUS	ID1	ID0	FLG_P S	FLG_A LS	0	0	0	0	00h
09h	PS CMD	INT_CT RL	SLP1_P S	SLP0_P S	IRDR_P S	IT1_PS	IT0_PS	INT_PS	SD_PS	01h
0Ah	PS DT	DT7_P S	DT6_P S	DT5_P S	DT4_P S	DT3_P S	DT2_P S	DT1_P S	DT0_P S	00h
0Bh	PS THDH	THDH7 _PS	THDH6 _PS	THDH5 _PS	THDH4 _PS	THDH3 _PS	THDH2 _PS	THDH1 _PS	THDH0 _PS	FFh
0Ch	PS THDL	THDL7 _PS	THDL6 _PS	THDL5 _PS	THDL4 _PS	THDL3 _PS	THDL2 _PS	THDL1 _PS	THDL0 _PS	00h

ALS Command Register (01 hex)

1. GAIN_ALS: Bits 7 and 6. The Gain setting for sensitivity range selection of ALS can be adjusted via I²C. The following table lists the possible values of GAIN_ALS.

BITS 7:6	MAX DETECT RANGE	LUX/LSB
00	57671	0.88
01	28836	0.44
10	14418	0.22
11	7209	0.11

2. IT_ALS: Bits 3 and 2. The APS-16D25-11-DF8/TR8 fundamental refresh timing of ALS can be tuned by IT_ALS. To cooperate with the ALS command register, (IT1_ALS :IT0_ALS), the designer has a very wide rang and flexible way to choose a refresh time for the system programming demand. In following table, the APS-16D25-11-DF8/TR8 fundamental refresh timing, (IT1_ALS:IT0_ALS) → (0 : 0) =x1, is 1T, i.e. 100ms. The other related refresh timing in the table are all changed by comparing with the fundamental timing. As the example in following table, it is below showing the timing table that the system designer can have a flexible way for choosing the desired fresh timing to.

BITS 3:2	RELATIVE REFRESH TIMING	REFRESH TIMING TABLE for ALS (Example)
00	1T	100ms
01	2T	200ms
10	4T	400ms
11	8T	800ms

Comparison Table for ALS (Sensitivity Range V.S Refresh Timing)

ALS function		Relative Refresh Timing							
		Bits 3:2							
		00		01		10		11	
		1T (100ms)		2T (200ms)		4T (400ms)		8T (800ms)	
Detection Range	Bits 7:6	Max. Lux	Lux/LSB	Max. Lux	Lux/LSB	Max. Lux	Lux/LSB	Max. Lux	Lux/LSB
	00	56761	0.88	28836	0.44	14418	0.22	7209	0.11
	01	28836	0.44	14418	0.22	7209	0.11	3604	0.055
	10	14418	0.22	7209	0.11	3604	0.055	1802	0.0275
	11	7209	0.11	3604	0.055	1802	0.0275	901	0.01375

3. INT_ALS: Bit 1. INT_ALS = 0, disable ALS interrupt. INT_ALS = 1, enable ALS interrupt.

BIT 1	OPERATION
0	ALS INT Disable
1	ALS INT Enable (Default)

4. SD_ALS: Bit 0. SD_ALS = 0, enable ALS. SD_ALS = 1, disable ALS.

BIT 0	OPERATION
0	ALS SD Enable
1	ALS SD Disable

ALS Data Register (02 hex and 03 hex)

The APS-16D25-11-DF8/TR8 has two 8-bit read-only registers to hold the data from LSB to MSB for ADC of ALS. The most significant bit (MSB) is accessed at 02 hex, and the least significant bit (LSB) is accessed at 03 hex. For 16-bit resolution, the data is from DT0_ALS to DT15_ALS. The registers are refreshed after every conversion cycle.

ALS Threshold Register (04, 05, 06 and 07 hex)

An ALS interrupt event (FLG_ALS) is governed by the high and low thresholds in register 04, 05, 06, and 07hex (ALS_THDH1, ALS_THDH2, ALS_THDL1, and ALSTHDL2). The user write a high and low threshold value to these registers and the APS-16D25-11-DF8/TR8 will issue an ALS interrupt flag if the actual count stored in registers 02hex and 03hex are outside the user’s programmed window. The user must write 0 to clear FLG_ALS.

Status Register (08 hex)

1. ID number; Bits 7 and 6. The ID number is 0b00 for APS-16D25-11-DF8/TR8. This registers is read only.
2. PS Interrupt flag; Bit 5. This is the status bit of the interrupt for PS. The bit is set to logic high when the interrupt thresholds have been triggered, and logic low when not yet triggered. Once triggered, INT pin stays low and the status bit stays high. Both interrupt pin and the status bit are cleared by writing “0”.

BIT 5	OPERATION
0	Interrupt is cleared or not triggered yet
1	Interrupt is triggered

3. ALS Interrupt flag; Bit 4. This is the status bit of the interrupt for ALS. The bit is set to logic high when the interrupt thresholds have been triggered, and logic low when not yet triggered. Once triggered, INT pin stays low and the status bit stays high. Both interrupt pin and the status bit are cleared by writing “0”.

BIT 4	OPERATION
0	Interrupt is cleared or not triggered yet
1	Interrupt is triggered

PS Command Register (09 hex)

1. Interrupt Control; Bit 7. This bit is used to control the interrupt mode.

BIT 7	OPERATION
0	Set /INT pin low if FLG_ALS or FLG_PS high (logical OR)
1	Set /INT pin low if FLG_ALS and FLG_PS high (logical AND)

2. PS sleep time: Bits 6, and 5. The proximity sleep time between IR LED pulses can be adjusted via I²C. The following table lists the possible values of SLP_PS.

BIT 6:5	PROXIMITY SLEEP TIME
00	10ms; sleep time between IR LED pulses is 10ms
01	30ms; sleep time between IR LED pulses is 30ms
10	90ms; sleep time between IR LED pulses is 90ms
11	270ms; sleep time between IR LED pulses is 270ms

3. Amplitude of IR sink current: Bit 4. This device provides current source to sink an external IR LED. The sink current can be programmed through IRDR_PS.

BIT 4	IRDR PIN SINK CURRENT
0	100mA current sink
1	200mA current sink

4. IT_PS: Bits 3 and 2. The APS-16D25-11-DF8/TR8 fundamental refresh timing of PS can be tuned by IT_PS. To cooperate with the PS command register, (IT1_PS : IT0_PS), the designer has a very wide range and flexible way to choose a refresh time for the system programming demand. In following table, APS-16D25-11-DF8/TR8 fundamental refresh timing, (IT1_PS : IT0_PS) → (0 : 0) = x1, is 1T, i.e. 0.2ms. The other related refresh timing in the table are all changed by comparing with the fundamental timing. As the example in following table, it is below showing the timing table that the system designer can have a flexible way for choosing the desired refresh timing to APS-16D25-11-DF8/TR8.

BITS 3:2	RELATIVE REFRESH TIMING	REFRESH TIMING TABLE for PS (Example)
00	1T	0.2ms
01	1.5T	0.3ms
10	2T	0.4ms
11	2.5T	0.5ms

5. INT_PS: Bit 1. INT_PS = 0, disable PS interrupt. INT_PS = 1, enable PS interrupt.

BIT 1	OPERATION
0	PS INT Disable
1	PS INT Enable

6. SD_PS: Bit 0. SD_PS = 0, enable PS. SD_PS = 1, disable PS.

BIT 0	OPERATION
0	PS SD Enable
1	PS SD Disable

PS Data Register (0A hex)

The APS-16D25-11-DF8/TR8 has 8-bit read-only registers to hold the data for ADC of PS. The registers are refreshed after every conversion cycle.

PS Threshold Register (0B and 0C hex)

A proximity interrupt event (FLG_PS) is governed by the high and low thresholds in register 0Bhex and 0Chex respectively. The user write a high and low threshold value to these registers and the APS-16D25-11-DF8/TR8 will issue an PS interrupt flag if the actual count stored in registers 0Ahex are outside the user's programmed window. The user must write 0 to clear FLG_PS. If the interrupt occurs due to near side (high threshold) and FLG_PS is clear by host, then interrupt will never occur again unless the device moves to far side (low threshold), and vice versa.

Spectral Response

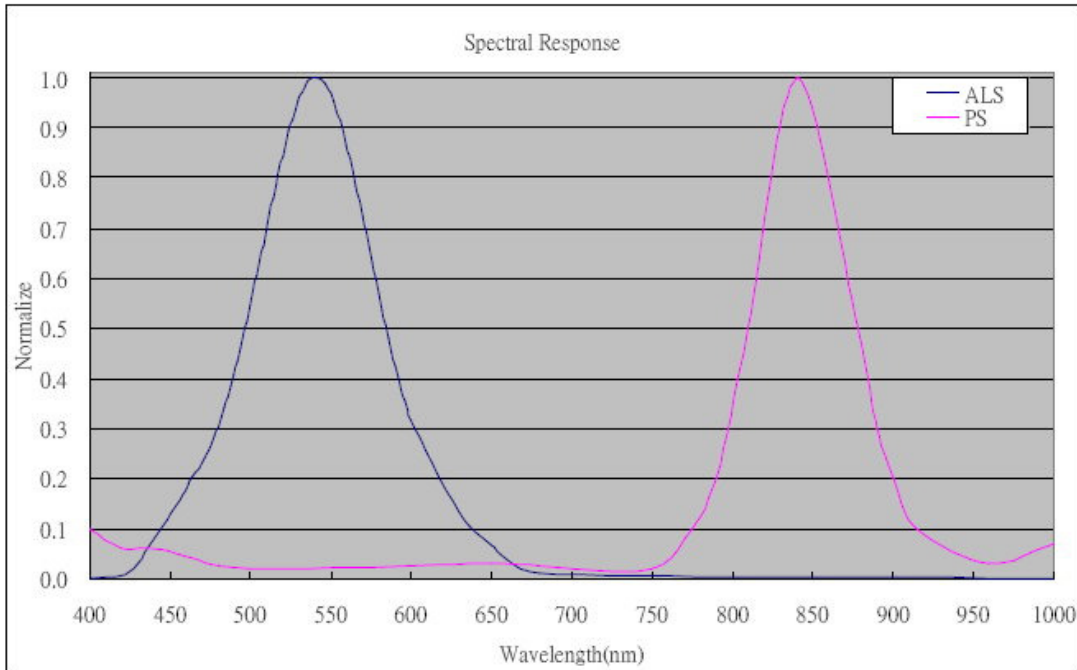

Spectral Response

Distance Detection for PS

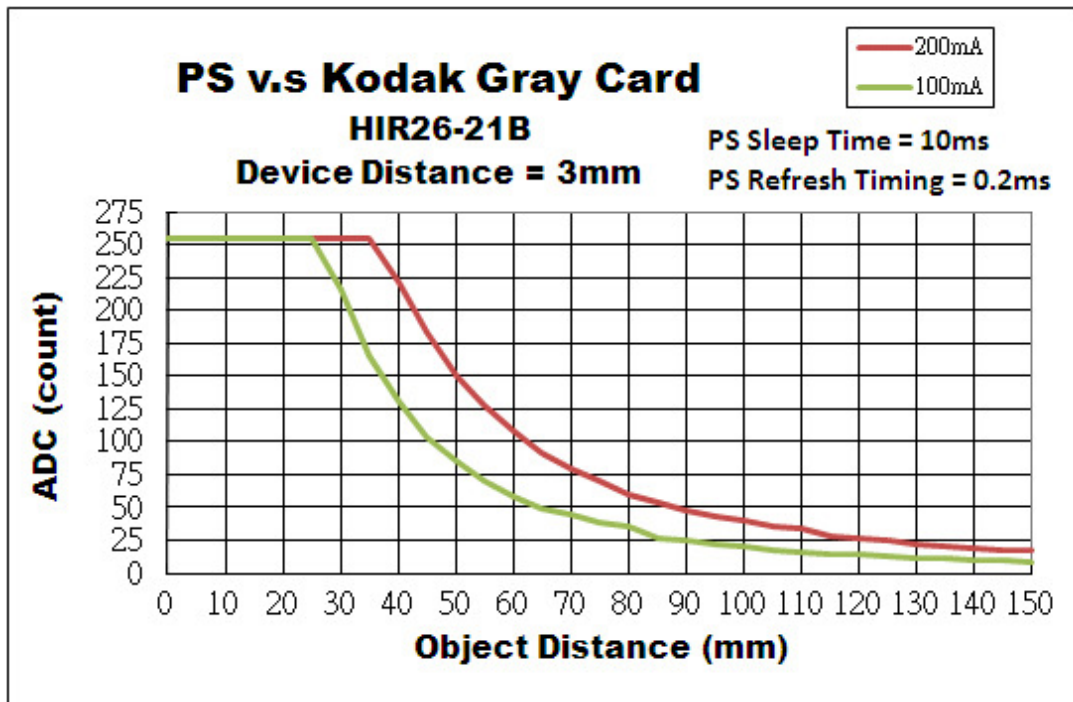

Recommended Solder Profile

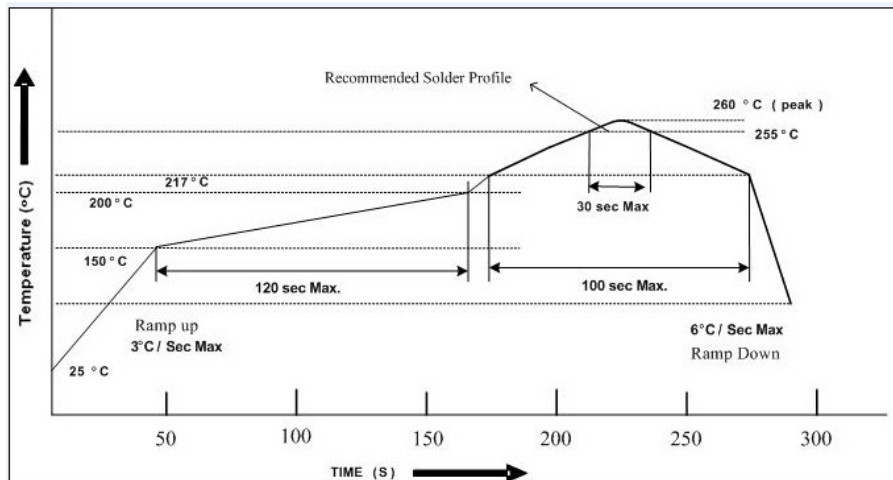

Notice:

1. Reflow soldering should not be done more than two times.
2. When soldering, do not put stress on the devices during heating.
3. After soldering, do not warp the circuit board.

Soldering Iron

Each terminal is to go to the tip of soldering iron temperature less than 350°C for 3 seconds within once in less than the soldering iron capacity 25W. Leave two seconds and more intervals, and do soldering of each terminal. Be careful because the damage of the product is often started at the time of the hand solder.

Repairing

Repair should not be done after the device have been soldered. When repairing is unavoidable, a double-head soldering iron should be used (as below figure). It should be confirmed beforehand whether the characteristics of the device will or will not be damaged by repairing.

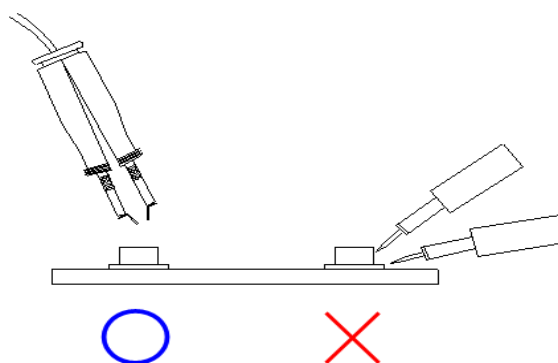

Packing Quantity Specification

2000 PCS/ 1 Reel

Label Format

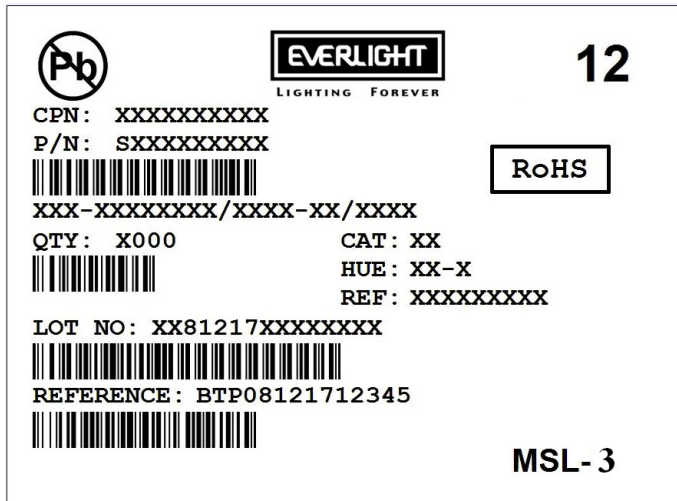

Reel Dimensions

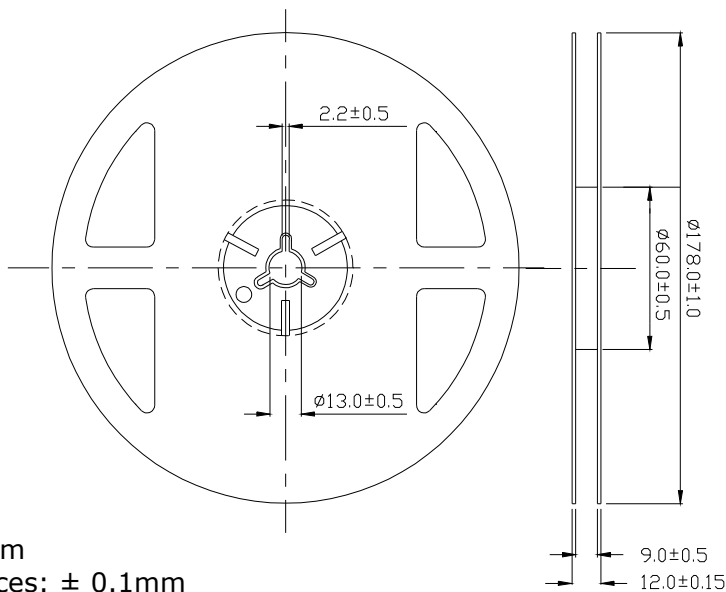

Unit: mm
 Tolerances: ± 0.1mm

Note:

1. Above specification may be changed without notice. EVERLIGHT will reserve authority on material change for above specification.
2. When using this product, please observe the absolute maximum ratings and the instructions for using outlined in these specification sheets. EVERLIGHT assumes no responsibility for any damage resulting from use of the product which does not comply with the absolute maximum ratings and the instructions included in these specification sheets.
3. Do not directly touch device.
4. These specification sheets include materials protected under copyright of EVERLIGHT's corporation. Please don't reproduce or cause anyone to reproduce them without EVERLIGHT's consent.