





TFT LCD Preliminary Specification

MODEL NO.: N154I1-L07

Customer : _____

Approved by : _____

Note :

| Liquid Crystal Display Division | |
|---|--|
| QRA Division. | OA Head Division. |
| Approval | Approval |
|  |  |

- CONTENTS -

| | | |
|---|-------|----|
| REVISION HISTORY | ----- | 3 |
| 1. GENERAL DESCRIPTION | ----- | 4 |
| 1.1 OVERVIEW | | |
| 1.2 FEATURES | | |
| 1.3 APPLICATION | | |
| 1.4 GENERAL SPECIFICATIONS | | |
| 1.5 MECHANICAL SPECIFICATIONS | | |
| 2. ABSOLUTE MAXIMUM RATINGS | ----- | 5 |
| 2.1 ABSOLUTE RATINGS OF ENVIRONMENT | | |
| 2.2 ELECTRICAL ABSOLUTE RATINGS | | |
| 2.2.1 TFT LCD MODULE | | |
| 2.2.2 BACKLIGHT UNIT | | |
| 3. ELECTRICAL CHARACTERISTICS | ----- | 7 |
| 3.1 TFT LCD MODULE | | |
| 3.2 BACKLIGHT UNIT | | |
| 4. BLOCK DIAGRAM | ----- | 10 |
| 4.1 TFT LCD MODULE | | |
| 4.2 BACKLIGHT UNIT | | |
| 5. INPUT TERMINAL PIN ASSIGNMENT | ----- | 11 |
| 5.1 TFT LCD MODULE | | |
| 5.2 BACKLIGHT UNIT | | |
| 5.3 TIMING DIAGRAM OF LVDS INPUT SIGNAL | | |
| 5.4 COLOR DATA INPUT ASSIGNMENT | | |
| 5.5 EDID DATA STRUCTURE | | |
| 5.6 EDID SIGNAL SPECIFICATION | | |
| 6. INTERFACE TIMING | ----- | 19 |
| 6.1 INPUT SIGNAL TIMING SPECIFICATIONS | | |
| 6.2 POWER ON/OFF SEQUENCE | | |
| 7. OPTICAL CHARACTERISTICS | ----- | 21 |
| 7.1 TEST CONDITIONS | | |
| 7.2 OPTICAL SPECIFICATIONS | | |
| 8. PRECAUTIONS | ----- | 25 |
| 8.1 HANDLING PRECAUTIONS | | |
| 8.2 STORAGE PRECAUTIONS | | |
| 8.3 OPERATION PRECAUTIONS | | |
| 9. PACKING | ----- | 26 |
| 9.1 CARTON | | |
| 9.2 PALLET | | |
| 10. DEFINITION OF LABELS | ----- | 28 |
| 10.1 CMO MODULE LABEL | | |
| 10.2 CARTON LABEL | | |

REVISION HISTORY

| Version | Date | Page (New) | Section | Description |
|----------------|--------------|-----------------------|----------------|---|
| Ver 1.0 | Sep.1, 04' | All | All | Preliminary specification first issued. |
| Ver 1.1 | Sep. 9, 04' | 21 | 7.2 | Modify Contrast Ration Spec |
| Ver 1.2 | Sep. 16, 04' | 21 | 7.2 | Modify brightness from 170 to 190 cd/m ² . |

1. GENERAL DESCRIPTION

1.1 OVERVIEW

N154I1 -L07 is a 15.4" TFT Liquid Crystal Display module with single CCFL Backlight unit and 30 pins LVDS interface. This module supports 1280 x 800 Wide-XGA mode and can display 262,144 colors. The optimum viewing angle is at 6 o'clock direction. The inverter module for Backlight is not built in.

1.2 FEATURES

- Thin and light weight
- WXGA (1280 x 800 pixels) resolution
- 3.3V LVDS (Low Voltage Differential Signaling) interface with 1 pixel/clock

1.3 APPLICATION

- TFT LCD Notebook

1.4 GENERAL SPECIFICATIONS

| Item | Specification | Unit | Note |
|--------------------|--|-------|------|
| Active Area | 331.2 (H) x 207.0 (V) (15.4" diagonal) | mm | (1) |
| Bezel Opening Area | 335.0 (H) x 210.7 (V) | mm | |
| Driver Element | a-si TFT active matrix | - | - |
| Pixel Number | 1280 x R.G.B. x 800 | pixel | - |
| Pixel Pitch | 0.2588 (H) x 0.2588 (V) | mm | - |
| Pixel Arrangement | RGB vertical stripe | - | - |
| Display Colors | 262,144 | color | - |
| Transmissive Mode | Normally white | - | - |
| Surface Treatment | Hard coating (3H), Glare | - | - |

1.5 MECHANICAL SPECIFICATIONS

| Item | | Min. | Typ. | Max. | Unit | Note |
|-------------|---------------|-------|-------|-------|------|------|
| Module Size | Horizontal(H) | 343.5 | 344.0 | 344.5 | mm | (1) |
| | Vertical(V) | 221.5 | 222.0 | 222.5 | mm | |
| | Depth(D) | - | 6.2 | 6.5 | mm | |
| Weight | | - | 625 | 645 | g | - |

Note (1) Please refer to the attached drawings for more information of front and back outline dimensions.

2. ABSOLUTE MAXIMUM RATINGS

2.1 ABSOLUTE RATINGS OF ENVIRONMENT

| Item | Symbol | Value | | Unit | Note |
|-------------------------------|------------------|-------|------|------|----------|
| | | Min. | Max. | | |
| Storage Temperature | T _{ST} | -20 | +60 | °C | (1) |
| Operating Ambient Temperature | T _{OP} | 0 | +50 | °C | (1), (2) |
| Shock (Non-Operating) | S _{NOP} | - | 220 | G | (3), (5) |
| Vibration (Non-Operating) | V _{NOP} | - | 1.5 | G | (4), (5) |

Note (1) Temperature and relative humidity range is shown in the figure below.

- (a) 90 %RH Max. ($T_a \leq 40\text{ }^\circ\text{C}$).
- (b) Wet-bulb temperature should be 39 °C Max. ($T_a > 40\text{ }^\circ\text{C}$).
- (c) No condensation .

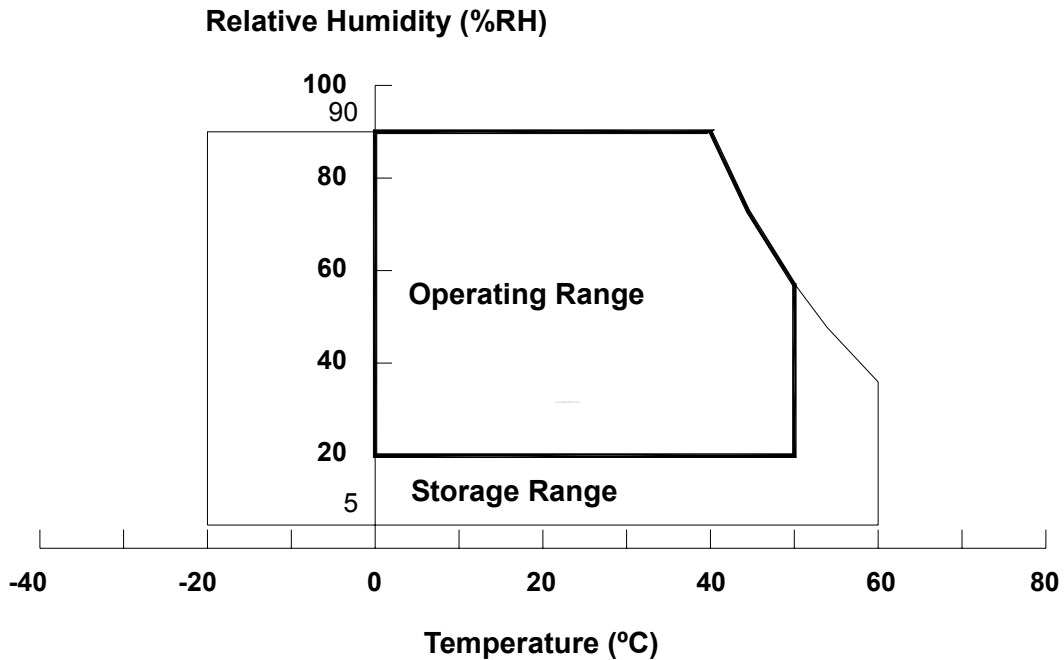

Note (2) The temperature of panel surface should be 0 °C Min. and 50 °C Max.

Note (3) 2ms, half sine wave, 1 time for ± X, ± Y, ± Z.

Note (4) 10 ~ 200 Hz, 0.5 Hr / Cycle, 1 cycles for each X, Y, Z. The fixing condition is shown as below:

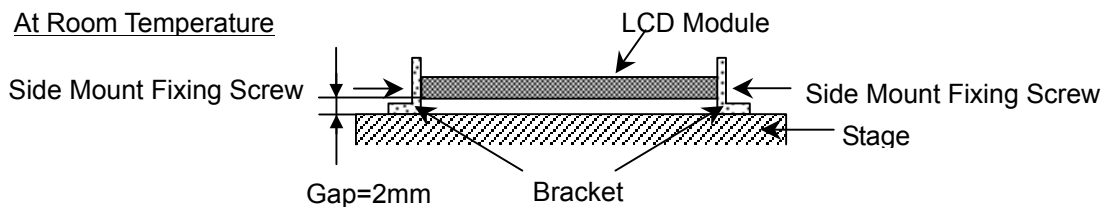

Note (5) At testing Vibration and Shock, the fixture in holding the module has to be hard and rigid enough so that the module would not be twisted or bent by the fixture.

2.2 ELECTRICAL ABSOLUTE RATINGS

2.2.1 TFT LCD MODULE

| Item | Symbol | Value | | Unit | Note |
|----------------------|-----------------|-------|----------------------|------|------|
| | | Min. | Max. | | |
| Power Supply Voltage | V _{CC} | -0.3 | +4.0 | V | (1) |
| Logic Input Voltage | V _{IN} | -0.3 | V _{CC} +0.3 | V | |

2.2.2 BACKLIGHT UNIT

| Item | Symbol | Value | | Unit | Note |
|----------------|----------------|-------|------|-------------------|-----------------------------------|
| | | Min. | Max. | | |
| Lamp Voltage | V _L | - | 2.5K | V _{RMS} | (1), (2), I _L = 6.5 mA |
| Lamp Current | I _L | - | 7.0 | mA _{RMS} | |
| Lamp Frequency | F _L | - | 80 | KHz | |

Note (1) Permanent damage to the device may occur if maximum values are exceeded. Function operation should be restricted to the conditions described under Normal Operating Conditions.

Note (2) Specified values are for lamp (Refer to Section 3.2 for further information).

3. ELECTRICAL CHARACTERISTICS

3.1 TFT LCD MODULE

T_a = 25 ± 2 °C

| Parameter | Symbol | Value | | | Unit | Note |
|--|-------------------|-----------------|------|------|------|------|
| | | Min. | Typ. | Max. | | |
| Power Supply Voltage | V _{CC} | 3.0 | 3.3 | 3.6 | V | - |
| Ripple Voltage | V _{RP} | - | - | 100 | mV | - |
| Rush Current | I _{RUSH} | - | - | 1.5 | A | (2) |
| Power Supply Current | White | - | 580 | - | mA | (3)a |
| | Black | - | 650 | - | mA | (3)b |
| | Vertical Stripe | - | 650 | - | mA | (3)c |
| Differential Input Voltage for LVDS Receiver Threshold | "H" Level | V _{IH} | - | +100 | mV | - |
| | "L" Level | V _{IL} | -100 | - | mV | - |
| Terminating Resistor | R _T | - | 100 | - | Ohm | - |

Note (1) The module should be always operated within above ranges.

Note (2) Measurement Conditions:

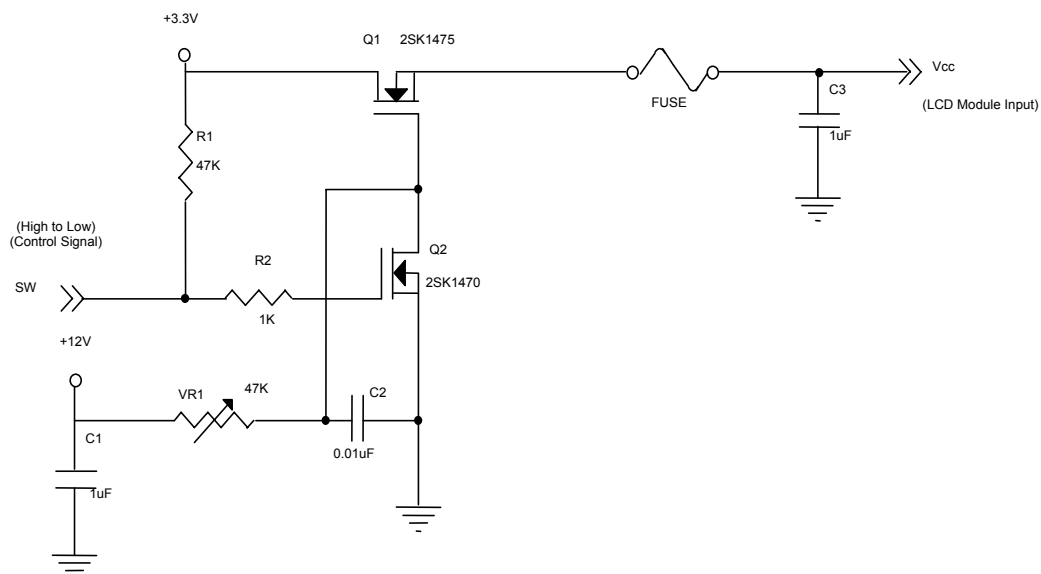

Vcc rising time is 470us

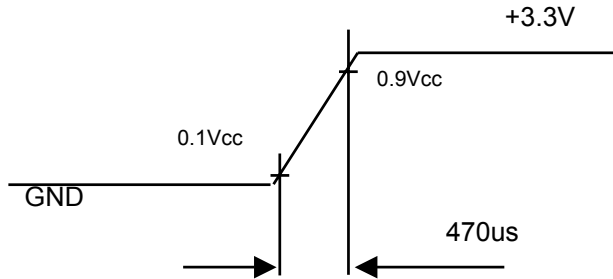

Note (3) The specified power supply current is under the conditions at Vcc = 3.3 V, Ta = 25 ± 2 °C, DC Current and f_v = 60 Hz, whereas a power dissipation check pattern below is displayed.

a. White Pattern



Active Area

b. Black Pattern

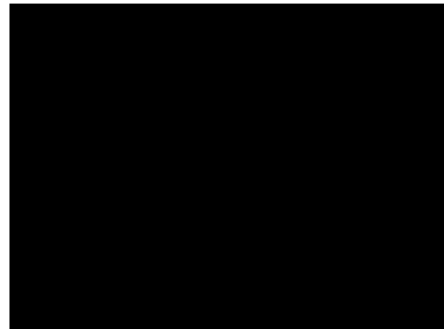

Active Area

c. Vertical Stripe Pattern

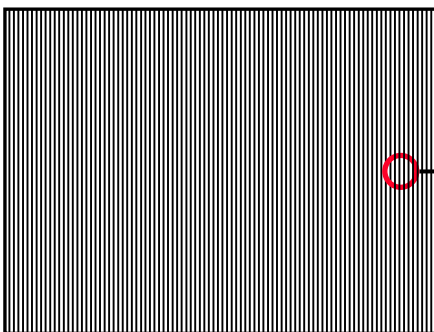

Active Area

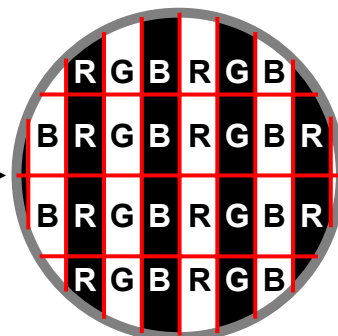

3.2 BACKLIGHT UNIT

Ta = 25 ± 2 °C

| Parameter | Symbol | Value | | | Unit | Note |
|----------------------|-----------------|--------|------|------------|-------------------|------------------------------|
| | | Min. | Typ. | Max. | | |
| Lamp Input Voltage | V _L | 585 | 650 | 715 | V _{RMS} | I _L = 6.5 mA |
| Lamp Current | I _L | 2.0 | 6.5 | 7.0 | mA _{RMS} | (1) |
| Lamp Turn On Voltage | V _S | - | - | 1230, 25°C | V _{RMS} | (2) |
| | | - | - | 1530, 0°C | V _{RMS} | (2) |
| Operating Frequency | F _L | 50 | - | 80 | KHz | (3) |
| Lamp Life Time | L _{BL} | 10,000 | - | - | Hrs | (5) |
| Power Consumption | P _L | - | 4.22 | - | W | (4), I _L = 6.5 mA |

Note (1) Lamp current is measured by utilizing a high frequency current meter as shown below:

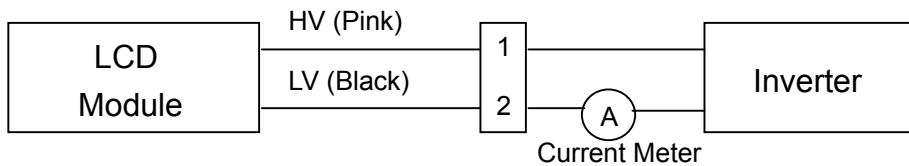

Note (2) The voltage shown above should be applied to the lamp for more than 1 second after startup. Otherwise the lamp may not be turned on.

Note (3) The lamp frequency may generate interference with horizontal synchronous frequency from the display, and this may cause line flow on the display. In order to avoid interference, the lamp frequency should be detached from the horizontal synchronous frequency and its harmonics as far as possible.

Note (4) $P_L = I_L \times V_L$

Note (5) The lifetime of lamp is defined as the time when it continues to operate under the conditions at Ta = 25 ± 2 °C and I_L = 6.5 mA_{RMS} until one of the following events occurs:

- (a) When the brightness becomes ≤ 50% of its original value.
- (b) When the effective ignition length becomes ≤ 80% of its original value. (Effective ignition length is defined as an area that the brightness is less than 70% compared to the center point.)

Note (6) The waveform of the voltage output of inverter must be area-symmetric and the design of the inverter must have specifications for the modularized lamp. The performance of the Backlight, such as lifetime or brightness, is greatly influenced by the characteristics of the DC-AC inverter for the lamp. All the parameters of an inverter should be carefully designed to avoid generating too much current leakage from high voltage output of the inverter. When designing or ordering the inverter please make sure that a poor lighting caused by the mismatch of the Backlight and the inverter (miss-lighting, flicker, etc.) never occurs. If the above situation is confirmed, the module should be operated in the same manners when it is installed in your instrument.

4. BLOCK DIAGRAM

4.1 TFT LCD MODULE

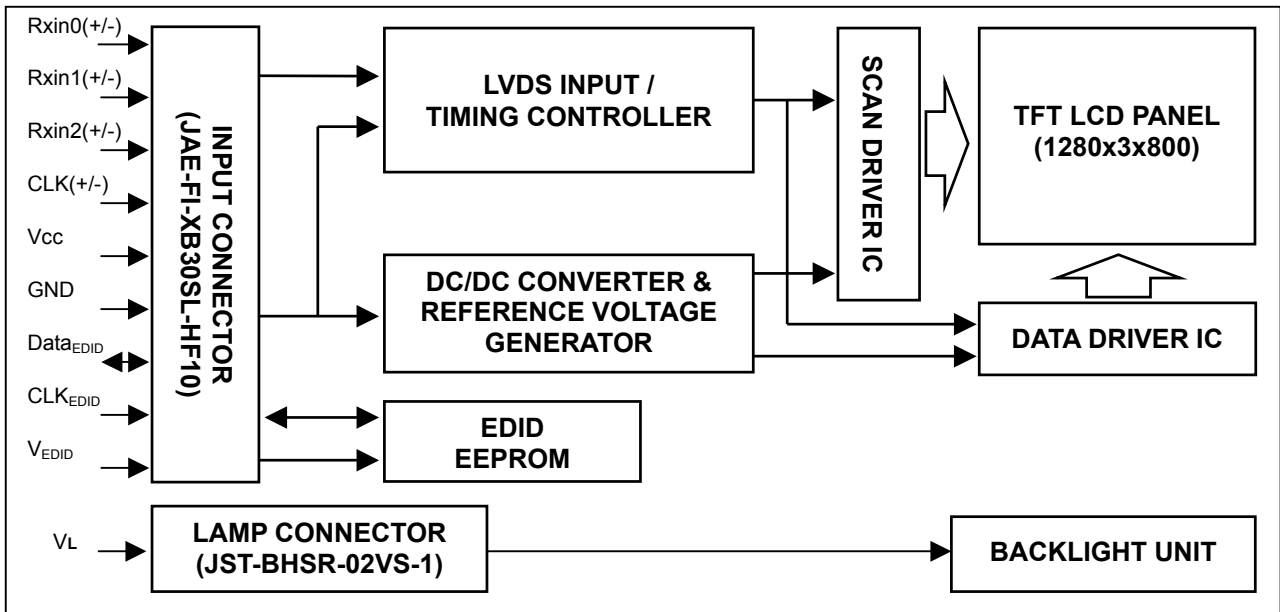

4.2 BACKLIGHT UNIT

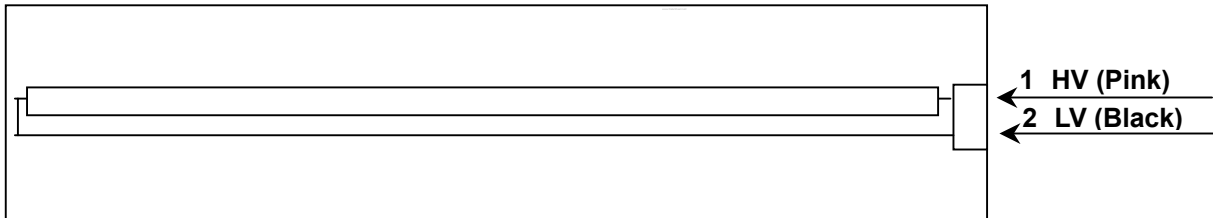

5. INPUT TERMINAL PIN ASSIGNMENT

5.1 TFT LCD MODULE

| Pin | Symbol | Description | Polarity | Remark |
|-----|----------------------|------------------------------|----------|---------------------------|
| 1 | Vss | Ground | | - |
| 2 | Vcc | Power Supply +3.3 V | | - |
| 3 | Vcc | Power Supply +3.3 V | | - |
| 4 | V _{EDID} | DDC +3.3 V | | - |
| 5 | NC | - | - | - |
| 6 | CLK _{EDID} | DDC Clock | | |
| 7 | Data _{EDID} | DDC Data | | |
| 8 | Rxin0- | LVDS Differential Data Input | Negative | - R0~R5,G0 |
| 9 | Rxin0+ | LVDS Differential Data Input | Positive | |
| 10 | Vss | Ground | | |
| 11 | Rxin1- | LVDS Differential Data Input | Negative | - G1~G5,B0,B1 |
| 12 | Rxin1+ | LVDS Differential Data Input | Positive | |
| 13 | Vss | Ground | | |
| 14 | Rxin2- | LVDS Differential Data Input | Negative | - B2~B5,Hsync,Vsync,DE |
| 15 | Rxin2+ | LVDS Differential Data Input | Positive | |
| 16 | Vss | Ground | | |
| 17 | CLK- | LVDS Clock Data Input | Negative | LVDS Level |
| 18 | CLK+ | LVDS Clock Data Input | Positive | |
| 19 | Vss | Ground | | |
| 20 | NC | - | - | - |
| 21 | NC | - | - | - |
| 22 | NC | - | - | - |
| 23 | NC | - | - | - |
| 24 | NC | - | - | - |
| 25 | NC | - | - | - |
| 26 | NC | - | - | - |
| 27 | NC | - | - | - |
| 28 | NC | - | - | - |
| 29 | NC | - | - | - |
| 30 | NC | - | - | - |

Note (1) Connector Part No.: JAE-FI-XB30SL-HF10 or equivalent

Note (2) User's connector Part No: JAE-FI-X30C2L or equivalent

5.2 BACKLIGHT UNIT

| Pin | Symbol | Description | Color |
|-----|--------|--------------|-------|
| 1 | HV | High Voltage | Pink |
| 2 | LV | Ground | Black |

Note (1) Connector Part No.: JST-BHSR-02VS-1 or equivalent

Note (2) User's connector Part No.: JST-SM02B-BHSS-1-TB or equivalent

5.3 TIMING DIAGRAM OF LVDS INPUT SIGNAL

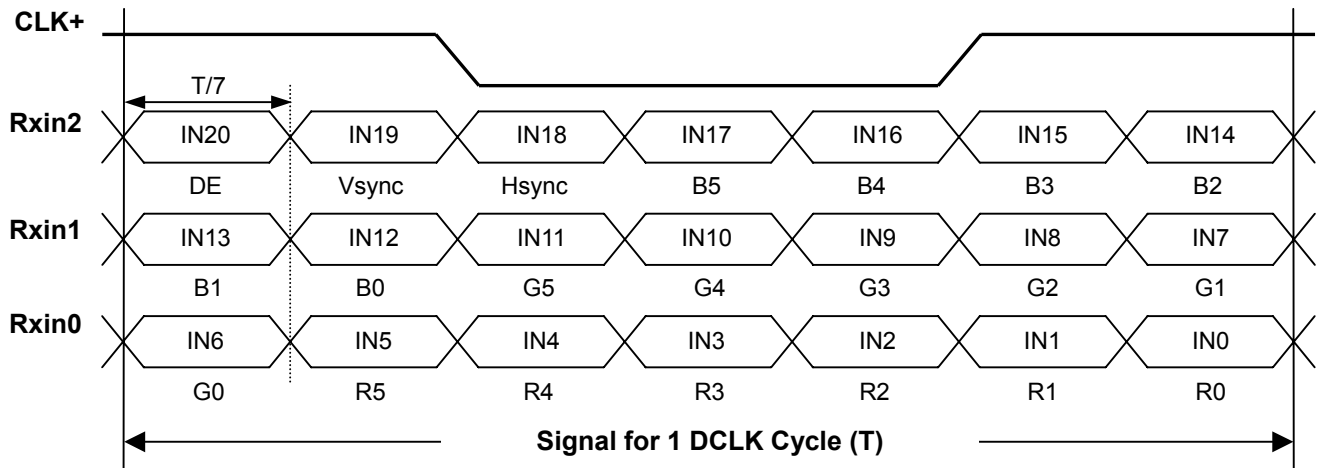

5.4 COLOR DATA INPUT ASSIGNMENT

The brightness of each primary color (red, green and blue) is based on the 6-bit gray scale data input for the color. The higher the binary input the brighter the color. The table below provides the assignment of color versus data input.

| Color | | Data Signal | | | | | | | | | | | | | | | | | |
|---------------------|---------------|-------------|----|----|----|----|----|-------|----|----|----|----|----|------|----|----|----|----|----|
| | | Red | | | | | | Green | | | | | | Blue | | | | | |
| | | R5 | R4 | R3 | R2 | R1 | R0 | G5 | G4 | G3 | G2 | G1 | G0 | B5 | B4 | B3 | B2 | B1 | B0 |
| Basic Colors | Black | 0 | 0 | 0 | 0 | 0 | 0 | 0 | 0 | 0 | 0 | 0 | 0 | 0 | 0 | 0 | 0 | 0 | 0 |
| | Red | 1 | 1 | 1 | 1 | 1 | 1 | 0 | 0 | 0 | 0 | 0 | 0 | 0 | 0 | 0 | 0 | 0 | 0 |
| | Green | 0 | 0 | 0 | 0 | 0 | 0 | 1 | 1 | 1 | 1 | 1 | 1 | 0 | 0 | 0 | 0 | 0 | 0 |
| | Blue | 0 | 0 | 0 | 0 | 0 | 0 | 0 | 0 | 0 | 0 | 0 | 0 | 1 | 1 | 1 | 1 | 1 | 1 |
| | Cyan | 0 | 0 | 0 | 0 | 0 | 0 | 1 | 1 | 1 | 1 | 1 | 1 | 1 | 1 | 1 | 1 | 1 | 1 |
| | Magenta | 1 | 1 | 1 | 1 | 1 | 1 | 0 | 0 | 0 | 0 | 0 | 0 | 0 | 1 | 1 | 1 | 1 | 1 |
| | Yellow | 1 | 1 | 1 | 1 | 1 | 1 | 1 | 1 | 1 | 1 | 1 | 1 | 0 | 0 | 0 | 0 | 0 | 0 |
| | White | 1 | 1 | 1 | 1 | 1 | 1 | 1 | 1 | 1 | 1 | 1 | 1 | 1 | 1 | 1 | 1 | 1 | 1 |
| Gray Scale Of Red | Red(0)/Dark | 0 | 0 | 0 | 0 | 0 | 0 | 0 | 0 | 0 | 0 | 0 | 0 | 0 | 0 | 0 | 0 | 0 | 0 |
| | Red(1) | 0 | 0 | 0 | 0 | 0 | 1 | 0 | 0 | 0 | 0 | 0 | 0 | 0 | 0 | 0 | 0 | 0 | 0 |
| | Red(2) | 0 | 0 | 0 | 0 | 1 | 0 | 0 | 0 | 0 | 0 | 0 | 0 | 0 | 0 | 0 | 0 | 0 | 0 |
| | : | : | : | : | : | : | : | : | : | : | : | : | : | : | : | : | : | : | : |
| | : | : | : | : | : | : | : | : | : | : | : | : | : | : | : | : | : | : | : |
| | : | : | : | : | : | : | : | : | : | : | : | : | : | : | : | : | : | : | : |
| | Red(61) | 1 | 1 | 1 | 1 | 0 | 1 | 0 | 0 | 0 | 0 | 0 | 0 | 0 | 0 | 0 | 0 | 0 | 0 |
| | Red(62) | 1 | 1 | 1 | 1 | 1 | 0 | 0 | 0 | 0 | 0 | 0 | 0 | 0 | 0 | 0 | 0 | 0 | 0 |
| Red(63) | 1 | 1 | 1 | 1 | 1 | 1 | 0 | 0 | 0 | 0 | 0 | 0 | 0 | 0 | 0 | 0 | 0 | 0 | |
| Gray Scale Of Green | Green(0)/Dark | 0 | 0 | 0 | 0 | 0 | 0 | 0 | 0 | 0 | 0 | 0 | 0 | 0 | 0 | 0 | 0 | 0 | 0 |
| | Green(1) | 0 | 0 | 0 | 0 | 0 | 0 | 0 | 0 | 0 | 0 | 1 | 0 | 0 | 0 | 0 | 0 | 0 | 0 |
| | Green(2) | 0 | 0 | 0 | 0 | 0 | 0 | 0 | 0 | 0 | 1 | 0 | 0 | 0 | 0 | 0 | 0 | 0 | 0 |
| | : | : | : | : | : | : | : | : | : | : | : | : | : | : | : | : | : | : | : |
| | : | : | : | : | : | : | : | : | : | : | : | : | : | : | : | : | : | : | : |
| | : | : | : | : | : | : | : | : | : | : | : | : | : | : | : | : | : | : | : |
| | Green(61) | 0 | 0 | 0 | 0 | 0 | 0 | 1 | 1 | 1 | 1 | 0 | 1 | 0 | 0 | 0 | 0 | 0 | 0 |
| | Green(62) | 0 | 0 | 0 | 0 | 0 | 0 | 1 | 1 | 1 | 1 | 1 | 0 | 0 | 0 | 0 | 0 | 0 | 0 |
| Green(63) | 0 | 0 | 0 | 0 | 0 | 0 | 1 | 1 | 1 | 1 | 1 | 1 | 0 | 0 | 0 | 0 | 0 | 0 | |
| Gray Scale Of Blue | Blue(0)/Dark | 0 | 0 | 0 | 0 | 0 | 0 | 0 | 0 | 0 | 0 | 0 | 0 | 0 | 0 | 0 | 0 | 0 | 0 |
| | Blue(1) | 0 | 0 | 0 | 0 | 0 | 0 | 0 | 0 | 0 | 0 | 0 | 0 | 0 | 0 | 0 | 0 | 0 | 1 |
| | Blue(2) | 0 | 0 | 0 | 0 | 0 | 0 | 0 | 0 | 0 | 0 | 0 | 0 | 0 | 0 | 0 | 0 | 1 | 0 |
| | : | : | : | : | : | : | : | : | : | : | : | : | : | : | : | : | : | : | : |
| | : | : | : | : | : | : | : | : | : | : | : | : | : | : | : | : | : | : | : |
| | : | : | : | : | : | : | : | : | : | : | : | : | : | : | : | : | : | : | : |
| | Blue(61) | 0 | 0 | 0 | 0 | 0 | 0 | 0 | 0 | 0 | 0 | 0 | 1 | 1 | 1 | 1 | 0 | 1 | 0 |
| | Blue(62) | 0 | 0 | 0 | 0 | 0 | 0 | 0 | 0 | 0 | 0 | 0 | 1 | 1 | 1 | 1 | 1 | 0 | 0 |
| Blue(63) | 0 | 0 | 0 | 0 | 0 | 0 | 0 | 0 | 0 | 0 | 0 | 1 | 1 | 1 | 1 | 1 | 1 | 1 | |

Note (1) 0: Low Level Voltage, 1: High Level Voltage

5.5 EDID DATA STRUCTURE

The EDID (Extended Display Identification Data) data formats are to support displays as defined in the VESA Plug & Display and FPD1 standards.

| Byte # (decimal) | Byte # (hex) | Field Name and Comments | Value (hex) | Value (binary) |
|---------------------|-----------------|---|----------------|-------------------|
| 0 | 0 | Header , Fixed | 00 | 00000000 |
| 1 | 1 | Header , Fixed | FF | 11111111 |
| 2 | 2 | Header , Fixed | FF | 11111111 |
| 3 | 3 | Header , Fixed | FF | 11111111 |
| 4 | 4 | Header , Fixed | FF | 11111111 |
| 5 | 5 | Header , Fixed | FF | 11111111 |
| 6 | 6 | Header , Fixed | FF | 11111111 |
| 7 | 7 | Header , Fixed | 00 | 00000000 |
| 8 | 8 | EISA Mfg. Code LSB 3 character in compressed ASCII: "CMO" -> 0D AF | 0D | 00001101 |
| 9 | 9 | EISA Mfg. Code LSB 3 character in compressed ASCII: "CMO" -> 0D AF | AF | 10101111 |
| 10 | 0A | Product code 1500, (hex, LSB first) | 00 | 00000000 |
| 11 | 0B | Product code 1500, (hex, LSB first) | 15 | 00010101 |
| 12 | 0C | 32-bit serial # Unused(01h for VESA, 00h for SPWG) | 00 | 00000000 |
| 13 | 0D | 32-bit serial # Unused(01h for VESA, 00h for SPWG) | 00 | 00000000 |
| 14 | 0E | 32-bit serial # Unused(01h for VESA, 00h for SPWG) | 00 | 00000000 |
| 15 | 0F | 32-bit serial # Unused(01h for VESA, 00h for SPWG) | 00 | 00000000 |
| 16 | 10 | Week of manufacture 1 - 53 (unused: 00h) : 02h fixed by CMO | 02 | 00000010 |
| 17 | 11 | Year of manufacture year - 1990(unsed:00h) : 0Dh (Year 2003) fixed by CMO | 0D | 00001101 |
| 18 | 12 | Version=1 | 01 | 00000001 |
| 19 | 13 | Revision=3 | 03 | 00000011 |
| 20 | 14 | Digital | 80 | 10000000 |
| 21 | 15 | Active area horizontal 33.12cm | 21 | 00100001 |
| 22 | 16 | Active area vertical 20.70cm | 15 | 00010101 |
| 23 | 17 | gamma * 100-100 = 2.2*100-100=120 | 78 | 01111000 |
| 24 | 18 | Feature support (no DPMS, Active off, RGB, Preferred Timing Mode) | 0A | 00001010 |
| 25 | 19 | Rx1 Rx0 Ry1 Ry0 Gx1 Gx0 Gy1 Gy0 | CA | 11001010 |
| 26 | 1A | Bx1 Bx0 By1 By0 Wx1 Wx0 Wy1 Wy0 | A5 | 10100101 |
| 27 | 1B | Rx=0.585 | 95 | 10010101 |
| 28 | 1C | Ry=0.355 | 5B | 01011011 |
| 29 | 1D | Gx=0.299 | 4C | 01001100 |
| 30 | 1E | Gy=0.584 | 95 | 10010101 |
| 31 | 1F | Bx=0.154 | 27 | 00100111 |
| 32 | 20 | By=0.135 | 22 | 00100010 |
| 33 | 21 | Wx=0.313 | 50 | 01010000 |
| 34 | 22 | Wy=0.329 | 54 | 01010100 |
| 35 | 23 | Not supported | 00 | 00000000 |
| 36 | 24 | Not supported | 00 | 00000000 |
| 37 | 25 | No manufacturer's specific timing | 00 | 00000000 |
| Byte # | Byte # | Field Name and Comments | Value | Value |

| (decimal) | (hex) | | (hex) | (binary) |
|---------------|---------------|--|--------------|--------------|
| 38 | 26 | 01h: Blank | 01 | 00000001 |
| 39 | 27 | 01h: Blank | 01 | 00000001 |
| 40 | 28 | 01h: Blank | 01 | 00000001 |
| 41 | 29 | 01h: Blank | 01 | 00000001 |
| 42 | 2A | 01h: Blank | 01 | 00000001 |
| 43 | 2B | 01h: Blank | 01 | 00000001 |
| 44 | 2C | 01h: Blank | 01 | 00000001 |
| 45 | 2D | 01h: Blank | 01 | 00000001 |
| 46 | 2E | 01h: Blank | 01 | 00000001 |
| 47 | 2F | 01h: Blank | 01 | 00000001 |
| 48 | 30 | 01h: Blank | 01 | 00000001 |
| 49 | 31 | 01h: Blank | 01 | 00000001 |
| 50 | 32 | 01h: Blank | 01 | 00000001 |
| 51 | 33 | 01h: Blank | 01 | 00000001 |
| 52 | 34 | 01h: Blank | 01 | 00000001 |
| 53 | 35 | 01h: Blank | 01 | 00000001 |
| 54 | 36 | Pixel clock/10000(LSB first) | BC | 10111100 |
| 55 | 37 | 71MHz/10000 = 7100 = 1BBCh | 1B | 00011011 |
| 56 | 38 | HActive(D7-D0) = 1280 mod 256 | 00 | 00000000 |
| 57 | 39 | HBlank(D7-D0) = 160 mod 256 | A0 | 10100000 |
| 58 | 3A | HActive(D11-D8) : HBlank(D11-D8) = 1280/256 : 160/256 | 50 | 01010000 |
| 59 | 3B | VActive(D7-D0) = 800 mod 256 | 20 | 00100000 |
| 60 | 3C | VBlank(D7-D0) = 23 mod 256 | 17 | 00010111 |
| 61 | 3D | VActive(D11-D8) : VBlank(D11-D8) = 800/256 : 23/256 | 30 | 00110000 |
| 62 | 3E | HSyncOffset(D7-D0) = HBorder+HFrontPorch = 48 | 30 | 00110000 |
| 63 | 3F | HSyncWidth(D7-D0) = 32 | 20 | 00100000 |
| 64 | 40 | VSyncoffset(D3-D0) : VSyncoffset(D3-D0) | 26 | 00100110 |
| 65 | 41 | HSyncOffset(D9-D8) : HSyncWidth(D9-D8) : VSyncoffset(D5-D4) : VSyncoffset(D5-D4) | 00 | 00000000 |
| 66 | 42 | HImageSize(mm, D7-D0) = 331 mod 256 | 4B | 01001011 |
| 67 | 43 | VImageSize(mm, D7-D0) = 207 mod 256 | CF | 11001111 |
| 68 | 44 | HImageSize(D11-D8) : VImageSize(D11-D8) = 331/256 : 207/256 | 10 | 00010000 |
| 69 | 45 | Hborder=0 | 00 | 00000000 |
| 70 | 46 | Vborder=0 | 00 | 00000000 |
| 71 | 47 | Non-interlaced, Normal Display, Digital separate, Positive Hsync, Negative Vsync | 1C | 00011100 |
| 72 | 48 | Flags: 00h when block used as descriptor | 00 | 00000000 |
| 73 | 49 | Flags: 00h when block used as descriptor | 00 | 00000000 |
| 74 | 4A | Flags: 00h when block used as descriptor | 00 | 00000000 |
| 75 | 4B | Data Type Tag: Monitor Range Limits (FDh) | FD | 11111101 |
| 76 | 4C | Flags: 00h when block used as descriptor | 00 | 00000000 |
| 77 | 4D | Min Vertical rate in Hz. 59Hz = 3Bh | 3B | 00111011 |
| 78 | 4E | Max Vertical rate in Hz. 61Hz = 3Dh | 3D | 00111101 |
| 79 | 4F | Min Horizontal Scan rate in kHz. 48kHz = 30h | 30 | 00110000 |
| 80 | 50 | Max Horizontal Scan rate in kHz. 50kHz = 31h | 32 | 00110010 |
| 81 | 51 | Max Pixel Clock in MHz/10. 80MHz/10 = 08h | 08 | 00001000 |
| Byte # | Byte # | Field Name and Comments | Value | Value |

| (decimal) | (hex) | | (hex) | (binary) |
|-----------|-------|--|-------|----------|
| 82 | 52 | No secondary timing formula supported : 00h | 00 | 00000000 |
| 83 | 53 | 0Ah | 0A | 00001010 |
| 84 | 54 | 20h | 20 | 00100000 |
| 85 | 55 | 20h | 20 | 00100000 |
| 86 | 56 | 20h | 20 | 00100000 |
| 87 | 57 | 20h | 20 | 00100000 |
| 88 | 58 | 20h | 20 | 00100000 |
| 89 | 59 | 20h | 20 | 00100000 |
| 90 | 5A | Flag | 00 | 00000000 |
| 91 | 5B | Flag | 00 | 00000000 |
| 92 | 5C | Flag | 00 | 00000000 |
| 93 | 5D | Data type tag : ASCII string (FEh) | FE | 11111110 |
| 94 | 5E | Flag | 00 | 00000000 |
| 95 | 5F | "N" | 4E | 01001110 |
| 96 | 60 | "1" | 31 | 00110001 |
| 97 | 61 | "5" | 35 | 00110101 |
| 98 | 62 | "4" | 34 | 00110100 |
| 99 | 63 | "I" | 49 | 01001001 |
| 100 | 64 | "1" | 31 | 00110001 |
| 101 | 65 | Terminator: 0Ah | 0A | 00001010 |
| 102 | 66 | padding: 20h | 20 | 00100000 |
| 103 | 67 | padding: 20h | 20 | 00100000 |
| 104 | 68 | padding: 20h | 20 | 00100000 |
| 105 | 69 | padding: 20h | 20 | 00100000 |
| 106 | 6A | padding: 20h | 20 | 00100000 |
| 107 | 6B | padding: 20h | 20 | 00100000 |
| 108 | 6C | Flag | 00 | 00000000 |
| 109 | 6D | Flag | 00 | 00000000 |
| 110 | 6E | Flag | 00 | 00000000 |
| 111 | 6F | Data type tag : Monitor Name as ASCII string (FCh) | FC | 11111100 |
| 112 | 70 | Flag | 00 | 00000000 |
| 113 | 71 | "C" | 43 | 01000011 |
| 114 | 72 | "o" | 6F | 01101111 |
| 115 | 73 | "I" | 6C | 01101100 |
| 116 | 74 | "o" | 6F | 01101111 |
| 117 | 75 | "r" | 72 | 01110010 |
| 118 | 76 | " " | 20 | 00100000 |
| 119 | 77 | "L" | 4C | 01001100 |
| 120 | 78 | "C" | 43 | 01000011 |
| 121 | 79 | "D" | 44 | 01000100 |
| 122 | 7A | Terminator: 0Ah | 0A | 00001010 |
| 123 | 7B | padding: 20h | 20 | 00100000 |
| 124 | 7C | padding: 20h | 20 | 00100000 |
| 125 | 7D | padding: 20h | 20 | 00100000 |
| 126 | 7E | No extension | 00 | 00000000 |
| 127 | 7F | One-byte checksum of entire 128 bytes EDID equals 00h. | 98 | 10011000 |

5.6 EDID SIGNAL SPECIFICATION

(1) EDID Power

| Parameter | Symbol | Test Condition | Min. | Typ. | Max. | Unit |
|----------------------|--------|----------------|------|------|------|------|
| Power supply voltage | Vcc | — | 2.7 | — | 5.5 | V |

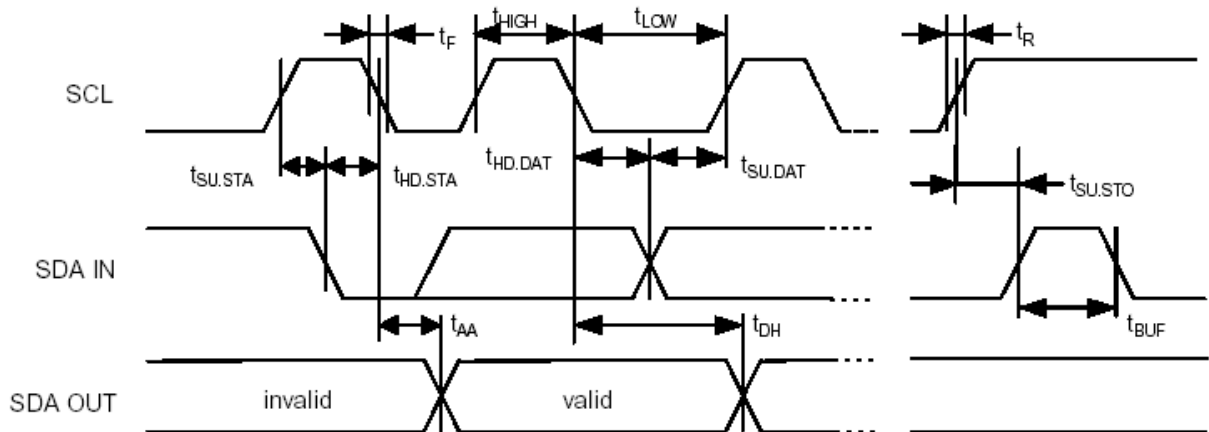

(2) DC characteristics

| Parameter | Symbol | Test Condition | Min | Typ | Max | Unit |
|---------------------------|------------------|--|-----------------------|------|-----------------------|------|
| Supply current Vcc=5.0V | I _{cc} | READ at 100kHz | — | 0.4 | 1.0 | mA |
| Supply current Vcc=5.0V | I _{cc} | WRITE at 100kHz | — | 2.0 | 3.0 | mA |
| Standby Current | I _{SB} | V _{in} =V _{cc} or V _{ss} | — | 1.6 | 4.0 | μA |
| Input Leakage Current | I _{LI} | V _{in} =V _{cc} or V _{ss} | — | 0.1 | 3.0 | μA |
| Onput Leakage Current | I _{LO} | V _{out} =V _{cc} or V _{ss} | — | 0.05 | 3.0 | μA |
| Input Low Level | V _{IL} | — | -1.0 | — | V _{cc} x 0.3 | V |
| Input High Level | V _{IH} | — | V _{cc} x 0.7 | — | V _{cc} +0.5 | V |
| Output Low Level Vcc=1.8V | V _{OL1} | I _{OL} =0.15mA | — | — | 0.2 | V |
| Output Low Level Vcc=3.0V | V _{OL2} | I _{OL} =2.1mA | — | — | 0.4 | V |

(3) AC characteristics (VCC=2.5~5.5V standard operation mode)

| Parameter | Symbol | Min | Max | Unit |
|---|---------------------|-----|-----|------|
| Clock Frequency, SCL | F _{SCL} | — | 100 | kHz |
| Clock Pulse Width Low | T _{LOW} | 4.7 | — | μs |
| Clock Pulse Width High | T _{HIGH} | 4.0 | — | μs |
| Noise Suppression Time | T _I | — | 100 | ns |
| Clock Low to Data Out Valid | T _{AA} | 0.1 | 4.5 | μs |
| Time the bus must be free before a new transmission can start | T _{BUF} | 4.7 | — | μs |
| Start Hold Time | T _{HD.STA} | 4.0 | — | μs |
| Start Set-up Time | T _{SU.STA} | 4.7 | — | μs |
| Data in Hold Time | T _{HD.DAT} | 0 | — | μs |
| Data in Set-up Time | T _{SU.DAT} | 200 | — | ns |
| Inputs Rise Time | T _R | — | 1.0 | μs |
| Inputs Fall Time | T _F | — | 300 | ns |
| Stop Set-up Time | T _{SU.STO} | 4.7 | — | μs |
| Data Out Hold Time | T _{DH} | 100 | — | ns |
| Write Cycle Time | T _{WR} | — | 10 | ms |

6. INTERFACE TIMING

6.1 INPUT SIGNAL TIMING SPECIFICATIONS

The input signal timing specifications are shown as the following table and timing diagram.

| Signal | Item | Symbol | Min. | Typ. | Max. | Unit | Note |
|--------------------------------|----------------|------------------|------|------|------|--------|------|
| Clock | Frequency | 1/Tc | - | 71 | 80 | MHz | - |
| | High Time | T _{CH} | 13 | - | - | nsec | - |
| | Low Time | T _{CL} | 13 | - | - | nsec | - |
| Data | Setup Time | T _{DS} | 4 | - | - | nsec | - |
| | Hold Time | T _{DH} | 4 | - | - | nsec | - |
| Vsync Frequency | Frequency | Vsync | - | 60 | - | Hz | |
| Hsync Frequency | Frequency | Hsync | - | 49.4 | - | KHz | |
| Data Enable | Pulse width | T _{DEP} | 100 | - | - | clocks | (1) |
| Data Enable | Setup Time | T _{ES} | 3.5 | 4.0 | - | nsec | (1) |
| Frame Frequency | Cycle | T _V | 810 | 823 | 2000 | lines | - |
| Vertical Active Display Term | Display Period | T _{VD} | 800 | 800 | 800 | lines | - |
| One Line Scanning Time | Cycle | T _H | 1360 | 1440 | 2000 | clocks | (2) |
| Horizontal Active Display Term | Display Period | T _{HD} | 1280 | 1280 | 1280 | clocks | - |

Note (1) Because this module is operated by DE only mode, Hsync and Vsync input signals should be set to low logic level or ground. Otherwise, this module would operate abnormally.

Note (2) The duration of DE signal must be longer than 1 clock period at every horizontal sync. period.

INPUT SIGNAL TIMING DIAGRAM

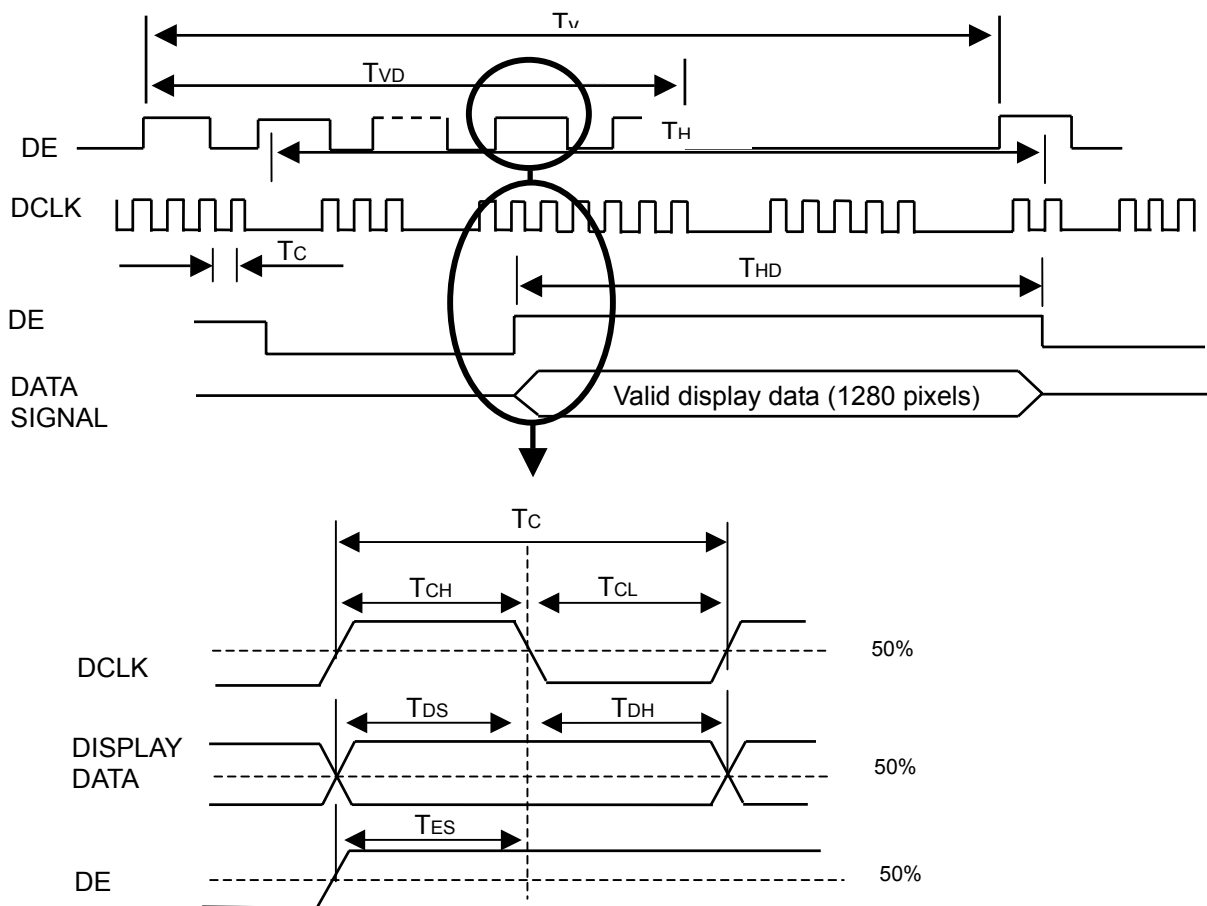

6.2 POWER ON/OFF SEQUENCE

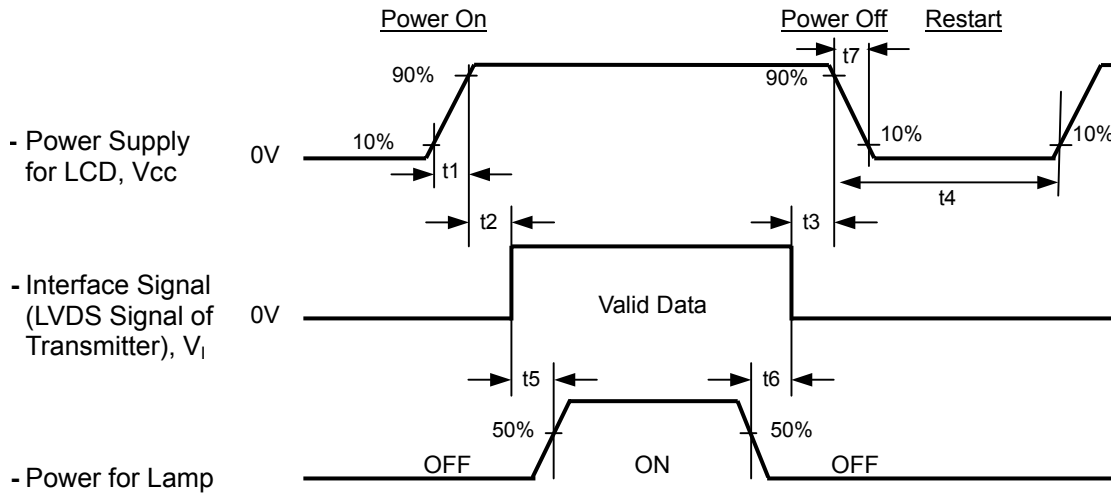

Timing Specifications:

$$0.5 < t_1 \leq 10 \text{ msec}$$

$$0 < t_2 \leq 45 \text{ msec}$$

$$0 < t_3 \leq 45 \text{ msec}$$

$$t_4 \geq 400 \text{ msec}$$

$$t_5 \geq 200 \text{ msec}$$

$$t_6 \geq 200 \text{ msec}$$

Note (1) Please avoid floating state of interface signal at invalid period.

Note (2) When the interface signal is invalid, be sure to pull down the power supply of LCD Vcc to 0 V.

Note (3) The Backlight inverter power must be turned on after the power supply for the logic and the interface signal is valid. The Backlight inverter power must be turned off before the power supply for the logic and the interface signal is invalid.

Note (4) Sometimes some slight noise shows when LCD is turned off (even backlight is already off). To avoid this phenomenon, we suggest that the Vcc falling time had better to follow

$$t_7 \geq 5 \text{ msec}$$

7. OPTICAL CHARACTERISTICS

7.1 TEST CONDITIONS

| Item | Symbol | Value | Unit |
|----------------------------|---|-------|------|
| Ambient Temperature | T _a | 25±2 | °C |
| Ambient Humidity | H _a | 50±10 | %RH |
| Supply Voltage | V _{CC} | 3.3 | V |
| Input Signal | According to typical value in "3. ELECTRICAL CHARACTERISTICS" | | |
| Inverter Current | I _L | 6.5 | mA |
| Inverter Driving Frequency | F _L | 55 | KHz |
| Inverter | Sumida-H05-4915 | | |

The measurement methods of optical characteristics are shown in Section 7.2. The following items should be measured under the test conditions described in Section 7.1 and stable environment shown in Note (6).

7.2 OPTICAL SPECIFICATIONS

| Item | | Symbol | Condition | Min. | Typ. | Max. | Unit | Note |
|----------------------------|------------|------------------|--|-------|-------|-------|-------------------|----------|
| Contrast Ratio | | CR | θ _x =0°, θ _y =0° Viewing Normal Angle | 400 | 500 | - | - | (2), (5) |
| Response Time | | T _R | | - | 10 | 30 | ms | (3) |
| | | T _F | | - | 20 | 50 | ms | |
| Central Luminance of White | | L _{AVE} | | 170 | 190 | - | cd/m ² | (5), (6) |
| White Variation | | δW | | - | - | 1.4 | - | (5), (6) |
| Cross Talk | | CT | | - | - | 4 | % | (4), (5) |
| Color Chromaticity | Red | R _x | | 0.571 | 0.601 | 0.631 | (1), (6) | (1), (6) |
| | | R _y | | 0.305 | 0.335 | 0.365 | | |
| | Green | G _x | | 0.290 | 0.320 | 0.350 | | |
| | | G _y | | 0.501 | 0.531 | 0.561 | | |
| | Blue | B _x | 0.126 | 0.156 | 0.186 | | | |
| | | B _y | 0.103 | 0.133 | 0.163 | | | |
| | White | W _x | 0.283 | 0.313 | 0.343 | | | |
| | | W _y | 0.299 | 0.329 | 0.359 | | | |
| Viewing Angle | Horizontal | θ _{x+} | CR≥10 | - | 45 | - | (1), (6) | (1), (6) |
| | | θ _{x-} | | - | 45 | - | | |
| | Vertical | θ _{y+} | | - | 15 | - | | |
| | | θ _{y-} | | - | 35 | - | | |

Note (1) Definition of Viewing Angle (θ_x, θ_y):

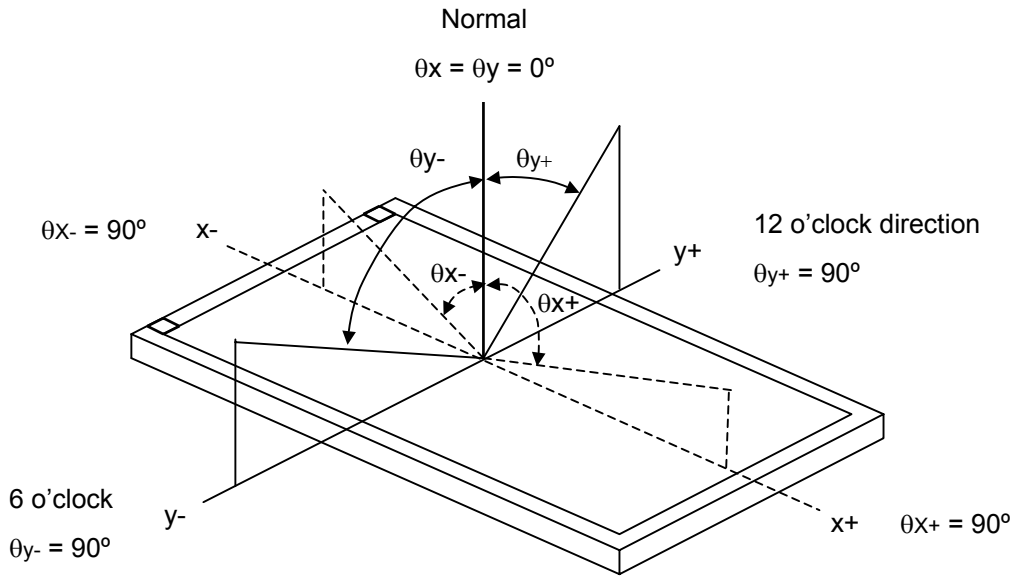

Note (2) Definition of Contrast Ratio (CR):

The contrast ratio can be calculated by the following expression.

$$\text{Contrast Ratio (CR)} = L_{63} / L_0$$

L₆₃: Luminance of gray level 63

L₀: Luminance of gray level 0

$$\text{CR} = \text{CR} (5)$$

CR (X) is corresponding to the Contrast Ratio of the point X at Figure in Note (7).

Note (3) Definition of Response Time (T_R, T_F):

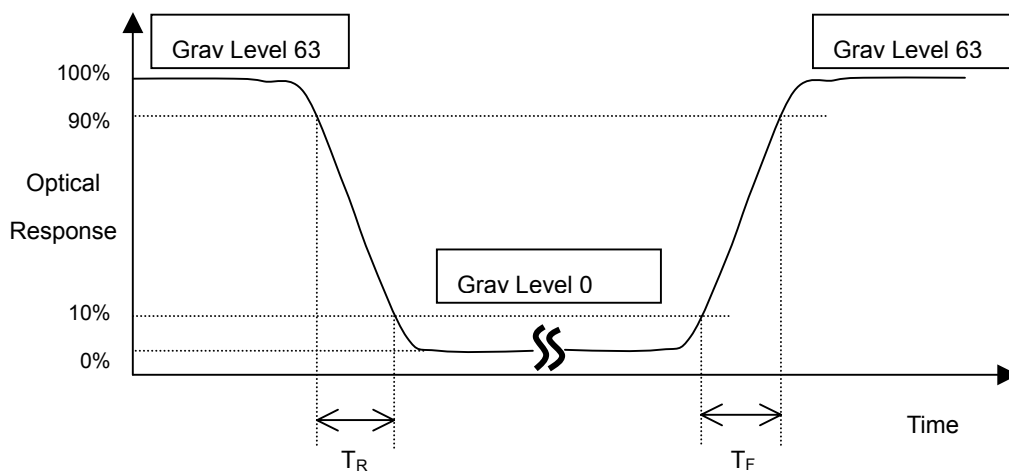

Note (4) Definition of Cross Talk (CT):

$$CT = |Y_B - Y_A| / Y_A \times 100 (\%)$$

Where:

Y_A = Luminance of measured location without gray level 0 pattern (cd/m^2)

Y_B = Luminance of measured location with gray level 0 pattern (cd/m^2)

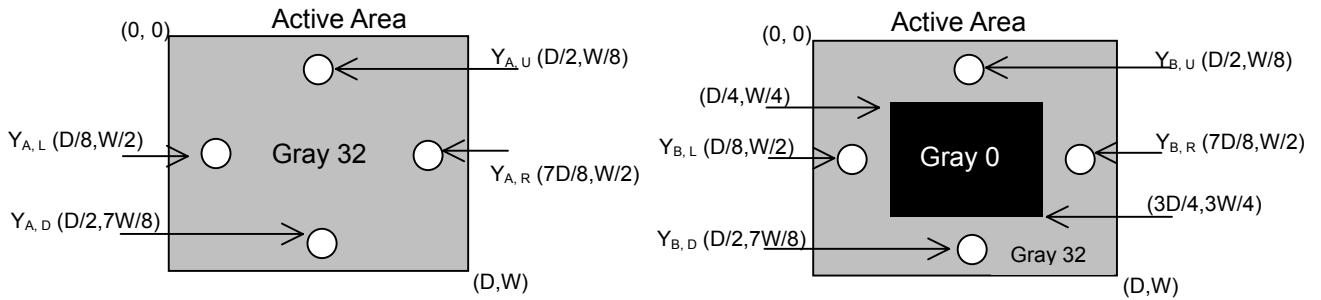

Note (5) Measurement Setup:

The LCD module should be stabilized at given temperature for 20 minutes to avoid abrupt temperature change during measuring. In order to stabilize the luminance, the measurement should be executed after lighting Backlight for 20 minutes in a windless room.

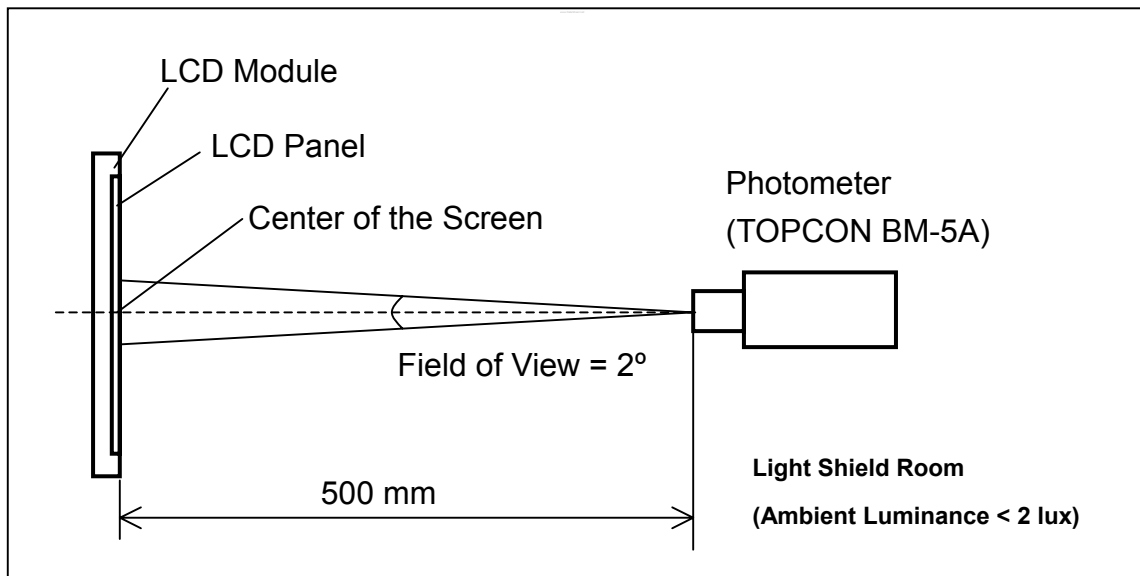

Note (6) Definition of White Variation (δW):

Measure the luminance of gray level 63 at 5 points

$$\delta W = \text{Maximum } [L(1), L(2), L(3), L(4), L(5)] / \text{Minimum } [L(1), L(2), L(3), L(4), L(5)]$$

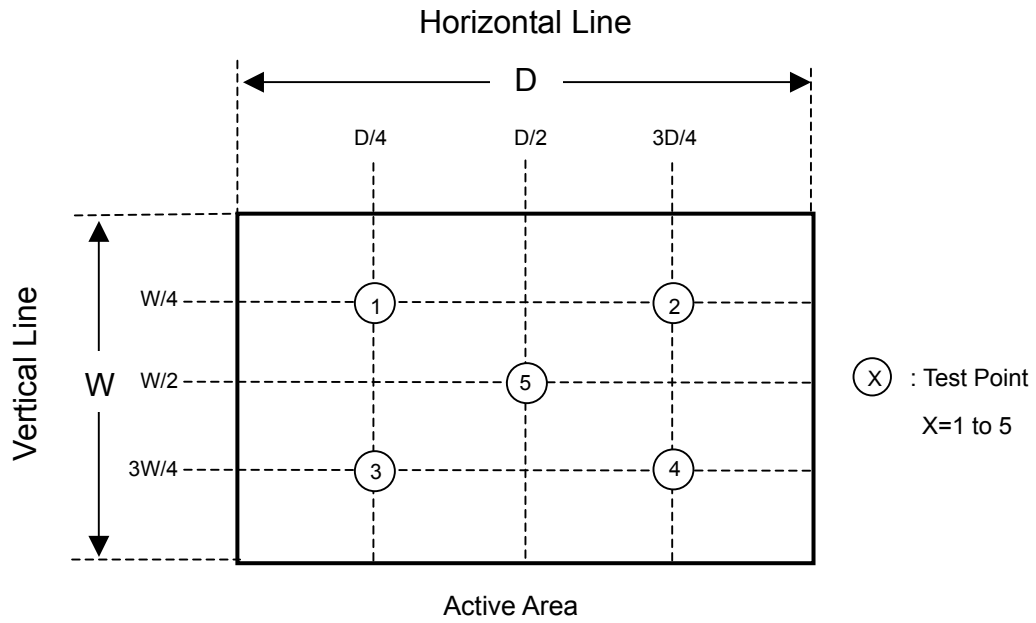

8. PRECAUTIONS

8.1 HANDLING PRECAUTIONS

- (1) The module should be assembled into the system firmly by using every mounting hole. Be careful not to twist or bend the module.
- (2) While assembling or installing modules, it can only be in the clean area. The dust and oil may cause electrical short or damage the polarizer.
- (3) Use fingerstalls or soft gloves in order to keep display clean during the incoming inspection and assembly process.
- (4) Do not press or scratch the surface harder than a HB pencil lead on the panel because the polarizer is very soft and easily scratched.
- (5) If the surface of the polarizer is dirty, please clean it by some absorbent cotton or soft cloth. Do not use Ketone type materials (ex. Acetone), Ethyl alcohol, Toluene, Ethyl acid or Methyl chloride. It might permanently damage the polarizer due to chemical reaction.
- (6) Wipe off water droplets or oil immediately. Staining and discoloration may occur if they left on panel for a long time.
- (7) If the liquid crystal material leaks from the panel, it should be kept away from the eyes or mouth. In case of contacting with hands, legs or clothes, it must be washed away thoroughly with soap.
- (8) Protect the module from static electricity, it may cause damage to the C-MOS Gate Array IC.
- (9) Do not disassemble the module.
- (10) Do not pull or fold the lamp wire.
- (11) Pins of I/F connector should not be touched directly with bare hands.

8.2 STORAGE PRECAUTIONS

- (1) High temperature or humidity may reduce the performance of module. Please store LCD module within the specified storage conditions.
- (2) It is dangerous that moisture come into or contacted the LCD module, because the moisture may damage LCD module when it is operating.
- (3) It may reduce the display quality if the ambient temperature is lower than 10 °C. For example, the response time will become slowly, and the starting voltage of lamp will be higher than the room temperature.

8.3 OPERATION PRECAUTIONS

- (1) Do not pull the I/F connector in or out while the module is operating.
- (2) Always follow the correct power on/off sequence when LCD module is connecting and operating. This can prevent the CMOS LSI chips from damage during latch-up.
- (3) The startup voltage of Backlight is approximately 1000 Volts. It may cause electrical shock while assembling with inverter. Do not disassemble the module or insert anything into the Backlight unit.

9. PACKING

9.1 CARTON

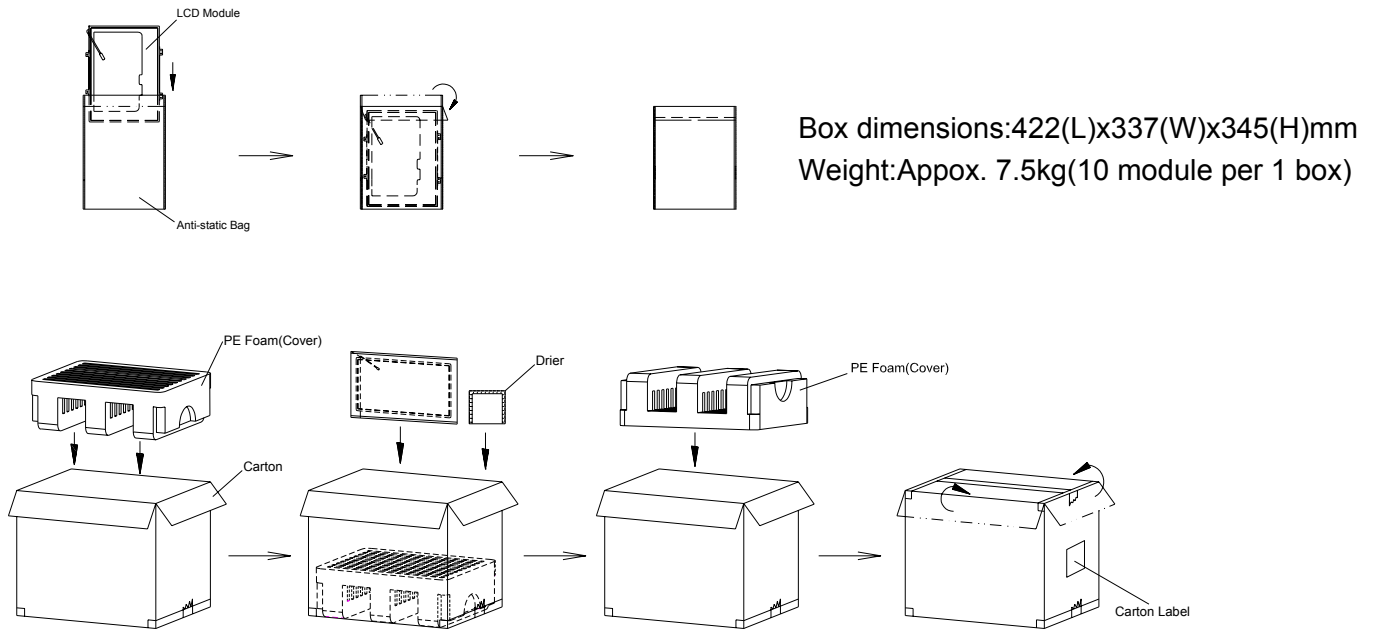

Packing testing criteria :

- (1) Packing drop : 1 corner, 3 edges, 6 faces, each direction for one time, follow ISTA standard.
- (2) Packing vibration : Random, follow ISTA standard.

9.2 PALLET

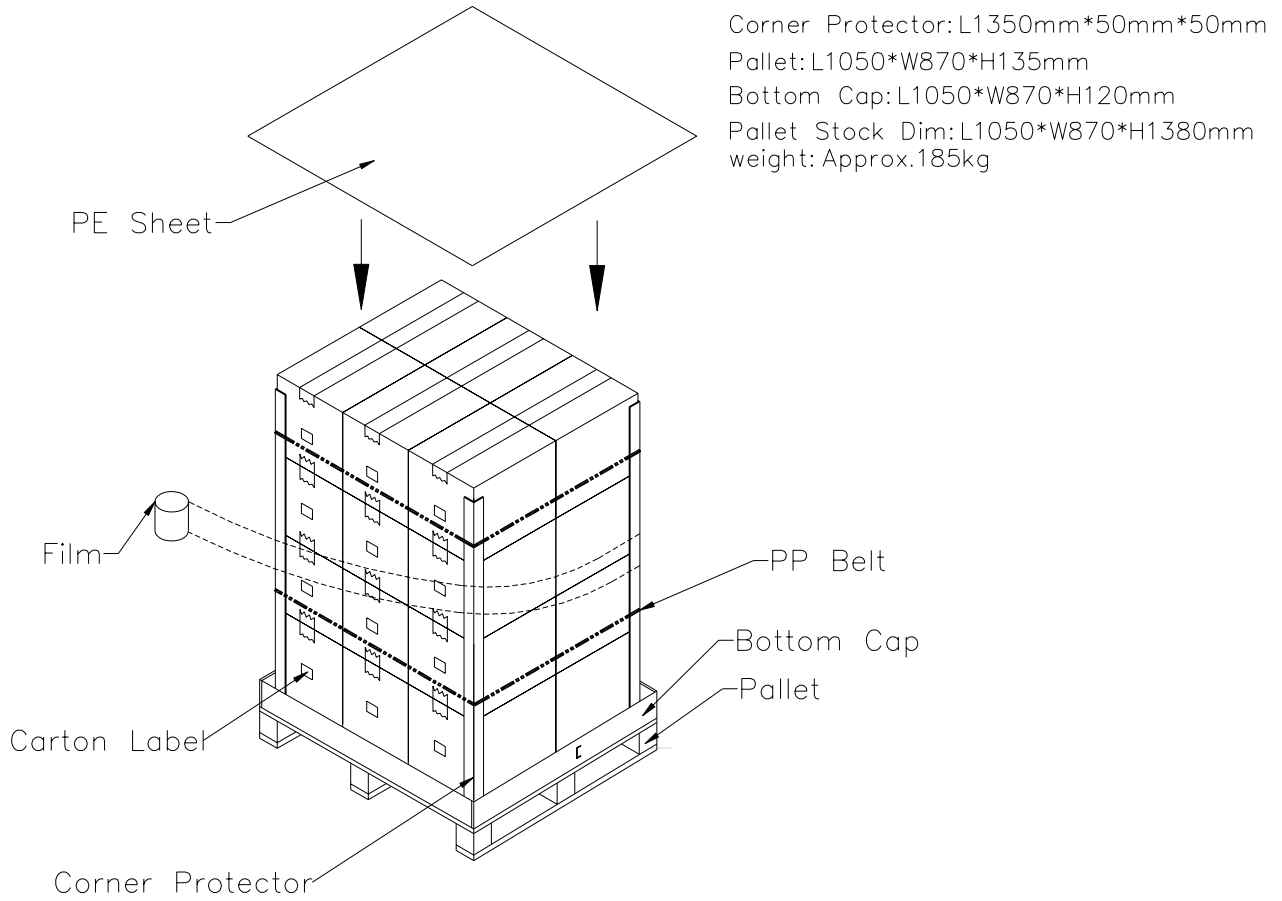

10. DEFINITION OF LABELS

10.1 CMO MODULE LABEL

The barcode nameplate is pasted on each module as illustration, and its definitions are as following explanation.

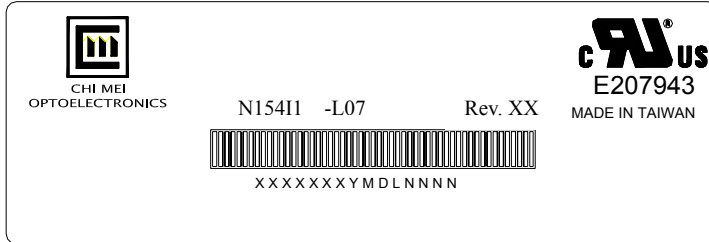

- (a) Model Name: N15411 - L07
- (b) Revision: Rev. XX, for example: C1, C2 ...etc.
- (c) Serial ID: XXXXXXYMDLNNNN

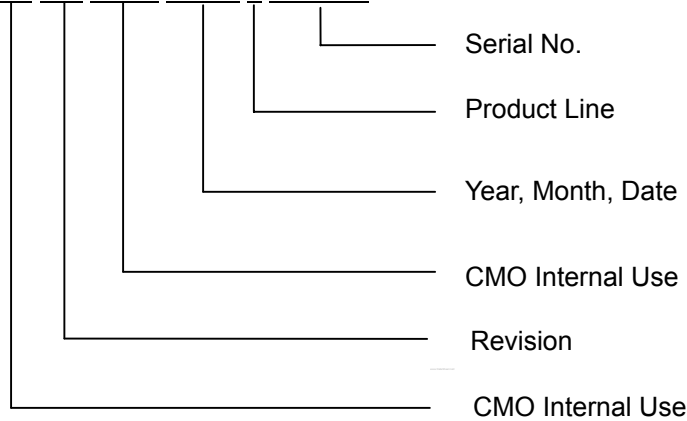

Serial ID includes the information as below:

- (a) Manufactured Date: Year: 1~9, for 2001~2009
 Month: 1~9, A~C, for Jan. ~ Dec.
 Day: 1~9, A~Y, for 1st to 31st, exclude I , O and U
- (b) Revision Code: cover all the change
- (c) Serial No.: Manufacturing sequence of product
- (d) Product Line: 1 -> Line1, 2 -> Line 2, ...etc.

10.2 CARTON LABEL

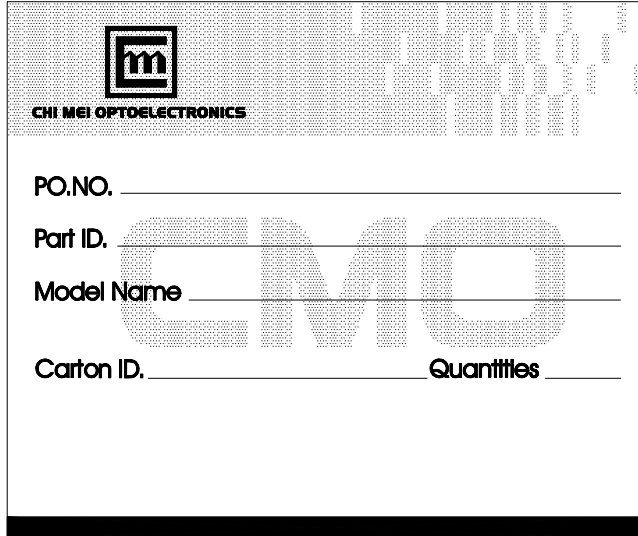

CHI MEI OPTOELECTRONICS

PO.NO. _____

Part ID. _____

Model Name _____

Carton ID. _____ Quantities _____

- Notes:
1. General Tolerance : ± 0.5
 2. The screw torque for mounting shall not exceed 2.0kgf-cm (0.196N-m).
 3. The gap between the panel and the bezel is 0.5mm max.

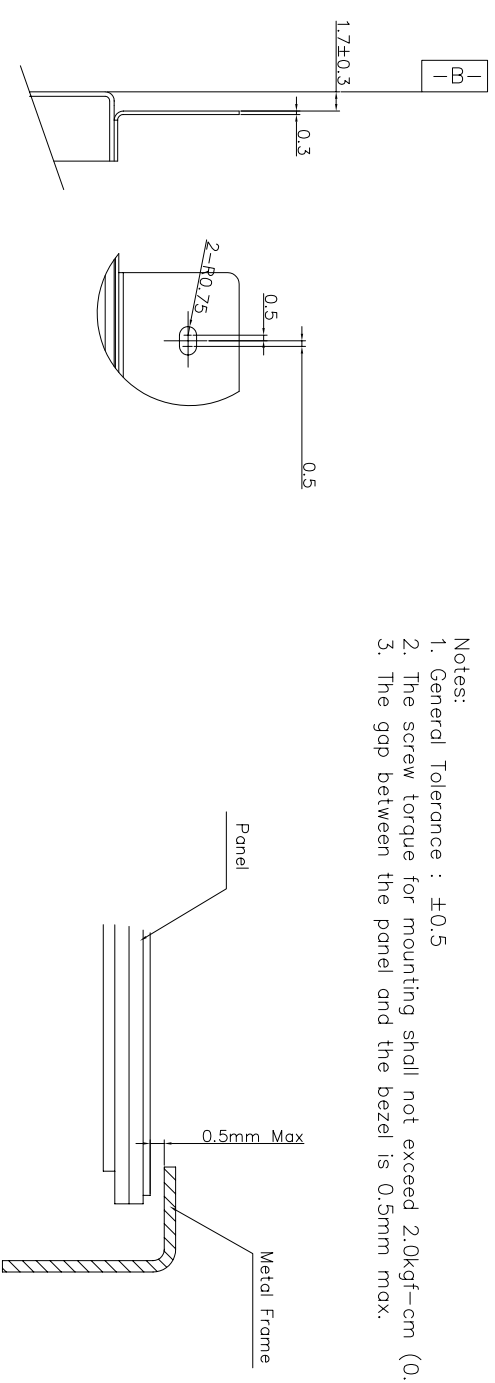

Detail : A
SCALE 4:1

panel section
SCALE 10:1

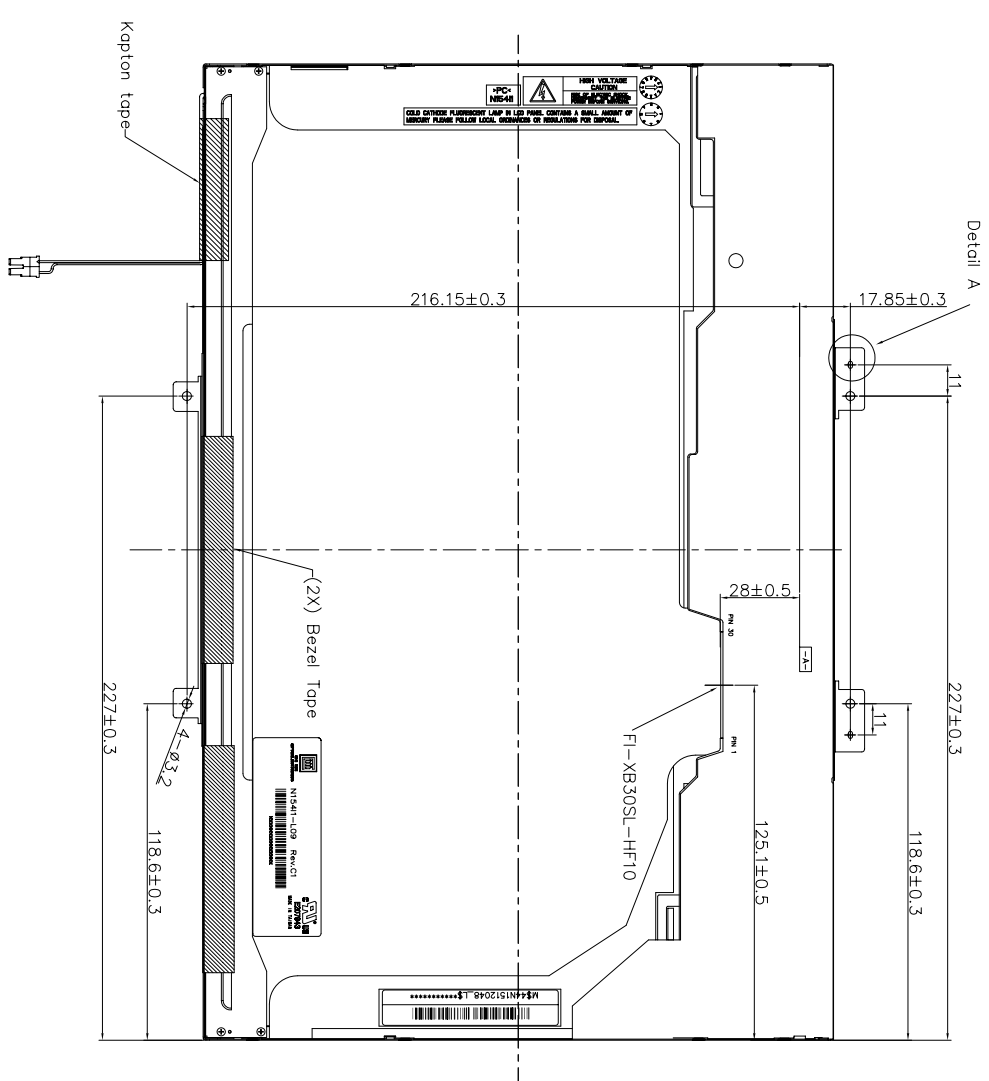
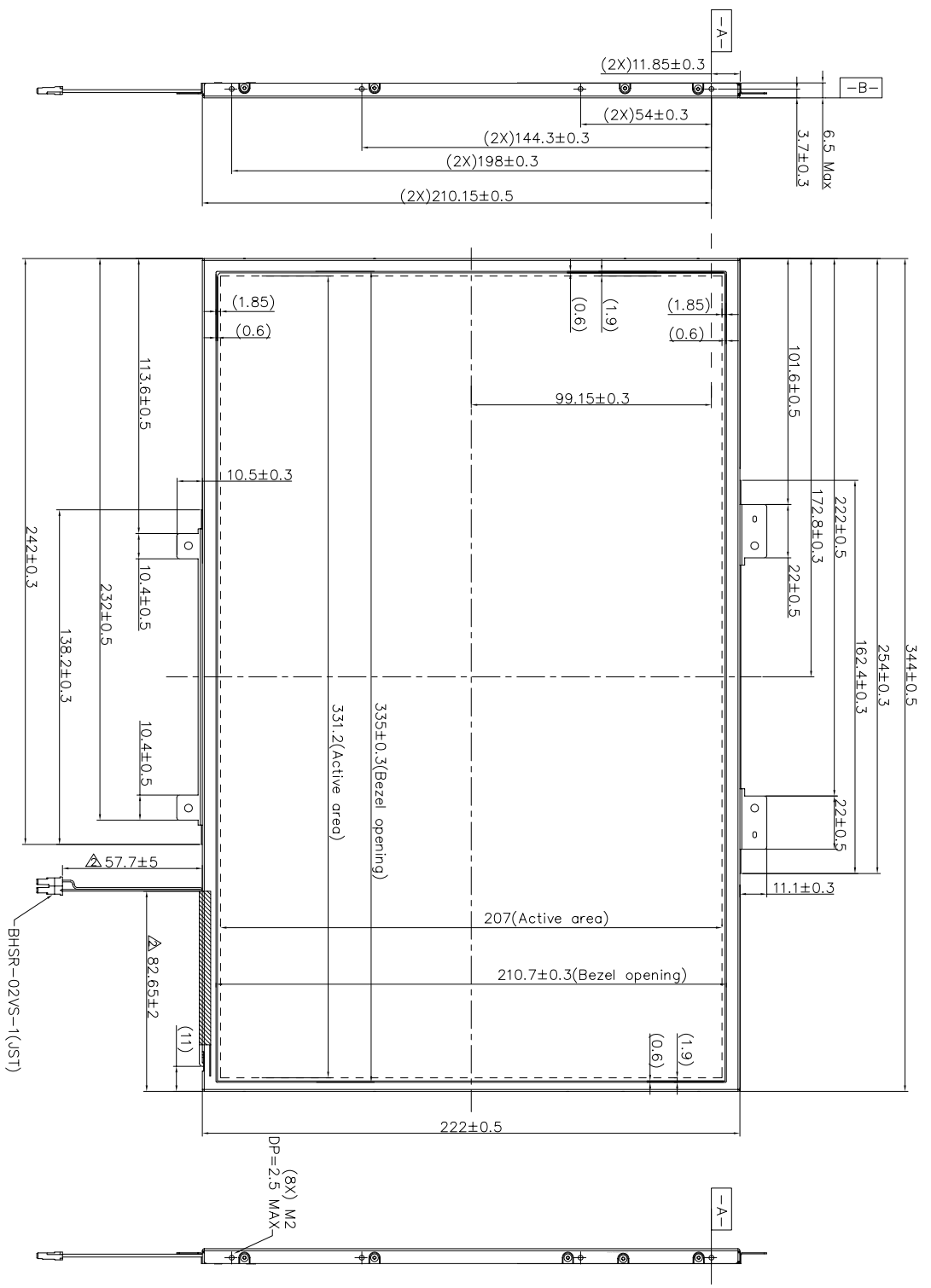

| | | | | | | | | | | | | | | | | | | | | | | | | | | | | | | | | | | | | | | | | | | | | | | | | | |
|---|-------------------|-------------|-------------|---------|------------|-------------|---------|---|--------|---|---|---|---|-------|-------------------|--|--|---------|-----|----------|-----------|-------------|------------|---------|--|---------|----------|----------|--|--|--|--------|---------------|----------|--|-------|-------|----------|---------------|------|-------------|-------|-----|--|--|---------|--|--|--|
| Mark | 1 | Description | 2 | Date | Changed_By | Approved_By | ECN No. | 4 | Remark | 5 | 6 | 7 | 8 | | | | | | | | | | | | | | | | | | | | | | | | | | | | | | | | | | | | |
| <table border="1"> <tr> <td>TITLE</td> <td colspan="3">Outline N1541-L07</td> <td>2D REV.</td> <td>1.0</td> </tr> <tr> <td>Approved</td> <td>Bill Sheu</td> <td>Drawing No.</td> <td>N154741011</td> <td>3D REV.</td> <td></td> </tr> <tr> <td>Checked</td> <td>Yule Lin</td> <td>Part No.</td> <td></td> <td></td> <td></td> </tr> <tr> <td>Drawer</td> <td>Mulcher Hsieh</td> <td>Material</td> <td></td> <td>Sheet</td> <td>1 / 1</td> </tr> <tr> <td>Designer</td> <td>Mulcher Hsieh</td> <td>Date</td> <td>01-Sep-2004</td> <td>Scale</td> <td>1:1</td> </tr> <tr> <td></td> <td></td> <td>Unit:mm</td> <td></td> <td></td> <td></td> </tr> </table> | | | | | | | | | | | | | | TITLE | Outline N1541-L07 | | | 2D REV. | 1.0 | Approved | Bill Sheu | Drawing No. | N154741011 | 3D REV. | | Checked | Yule Lin | Part No. | | | | Drawer | Mulcher Hsieh | Material | | Sheet | 1 / 1 | Designer | Mulcher Hsieh | Date | 01-Sep-2004 | Scale | 1:1 | | | Unit:mm | | | |
| TITLE | Outline N1541-L07 | | | 2D REV. | 1.0 | | | | | | | | | | | | | | | | | | | | | | | | | | | | | | | | | | | | | | | | | | | | |
| Approved | Bill Sheu | Drawing No. | N154741011 | 3D REV. | | | | | | | | | | | | | | | | | | | | | | | | | | | | | | | | | | | | | | | | | | | | | |
| Checked | Yule Lin | Part No. | | | | | | | | | | | | | | | | | | | | | | | | | | | | | | | | | | | | | | | | | | | | | | | |
| Drawer | Mulcher Hsieh | Material | | Sheet | 1 / 1 | | | | | | | | | | | | | | | | | | | | | | | | | | | | | | | | | | | | | | | | | | | | |
| Designer | Mulcher Hsieh | Date | 01-Sep-2004 | Scale | 1:1 | | | | | | | | | | | | | | | | | | | | | | | | | | | | | | | | | | | | | | | | | | | | |
| | | Unit:mm | | | | | | | | | | | | | | | | | | | | | | | | | | | | | | | | | | | | | | | | | | | | | | | |

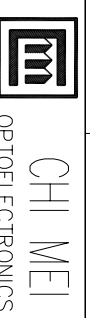

ALL RIGHTS RESERVED. COPYING FORBIDDEN.