

# MITSUBISHI IGBT MODULES

## CM75MX-12A

HIGH POWER SWITCHING USE

### CM75MX-12A



- Ic ..... 75A
- VCES ..... 600V
- CIB (3-phase Converter + 3-phase Inverter + Brake)
- Flatbase Type / Insulated Package / Copper base plate
- RoHS Directive compliant

### APPLICATION

General purpose Inverters, Servo Amplifiers

### OUTLINE DRAWING & CIRCUIT DIAGRAM

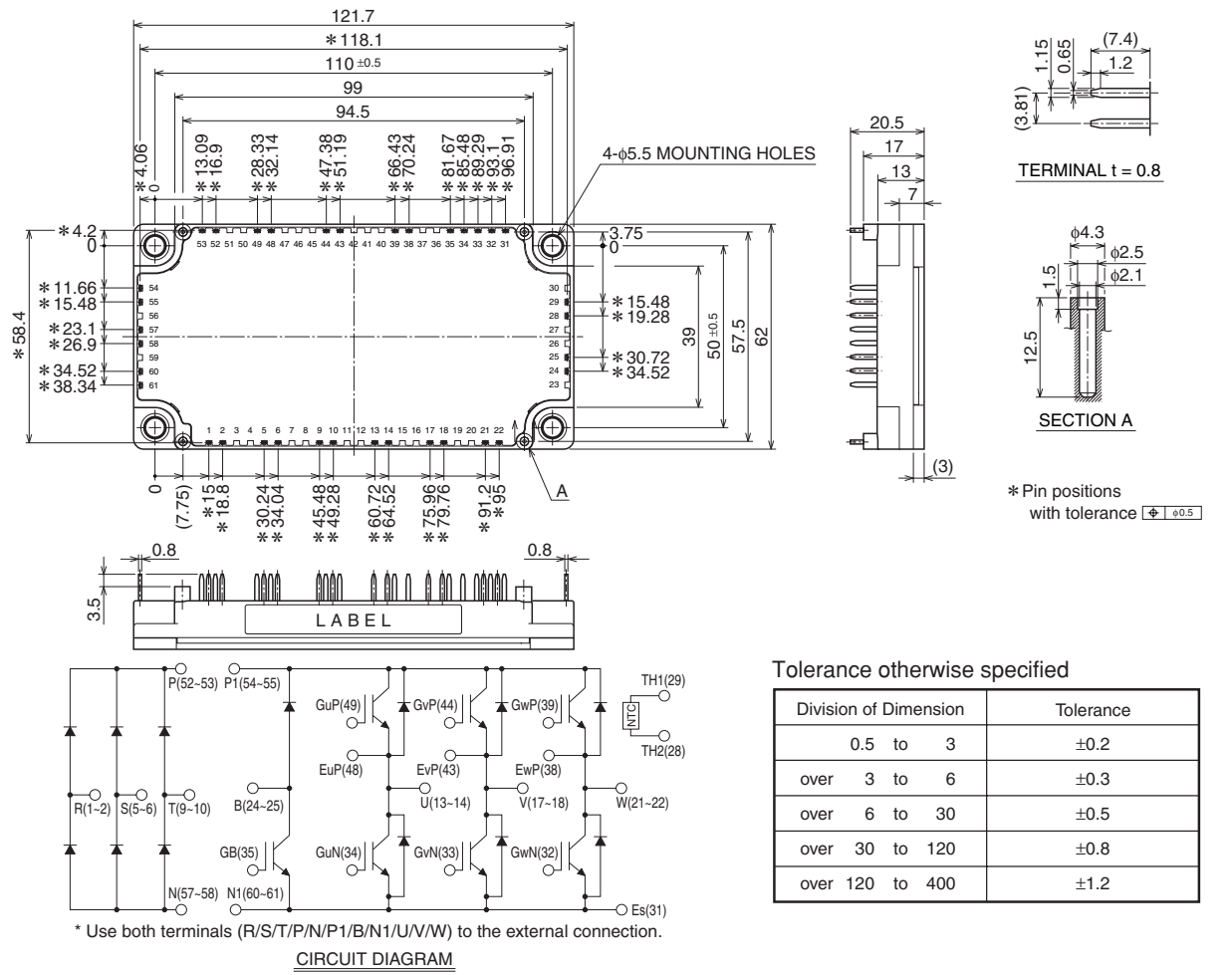

# CM75MX-12A

## HIGH POWER SWITCHING USE

### ABSOLUTE MAXIMUM RATINGS (T<sub>j</sub> = 25°C, unless otherwise specified)

#### INVERTER PART

Symbol	Parameter	Conditions	Rating	Unit
V <sub>CES</sub>	Collector-emitter voltage	G-E Short	600	V
V <sub>GES</sub>	Gate-emitter voltage	C-E Short	±20	
I <sub>C</sub>	Collector current	DC, T <sub>c</sub> = 70°C (Note. 1)	75	A
I <sub>CRM</sub>		Pulse (Note. 4)	150	
P <sub>tot</sub>	Maximum collector dissipation	T <sub>c</sub> = 25°C (Note. 1, 5)	280	W
I <sub>E</sub> (Note.3)	Emitter current	T <sub>c</sub> = 25°C (Note. 1)	75	A
I <sub>ERM</sub> (Note.3)	(Free wheeling diode forward current)	Pulse (Note. 4)	150	

#### BRAKE PART

Symbol	Parameter	Conditions	Rating	Unit
V <sub>CES</sub>	Collector-emitter voltage	G-E Short	600	V
V <sub>GES</sub>	Gate-emitter voltage	C-E Short	±20	
I <sub>C</sub>	Collector current	DC, T <sub>c</sub> = 97°C (Note. 1)	50	A
I <sub>CRM</sub>		Pulse (Note. 4)	100	
P <sub>tot</sub>	Maximum collector dissipation	T <sub>c</sub> = 25°C (Note. 1, 5)	280	W
V <sub>RRM</sub> (Note.3)	Repetitive peak reverse voltage		600	V
I <sub>F</sub> (Note.3)	Forward current	T <sub>c</sub> = 25°C (Note. 1)	50	A
I <sub>FRM</sub> (Note.3)		Pulse (Note. 4)	100	

#### CONVERTER PART

Symbol	Parameter	Conditions	Rating	Unit
V <sub>RRM</sub>	Repetitive peak reverse voltage		800	V
E <sub>a</sub>	Recommended AC input voltage		220	J
I <sub>o</sub>	DC output current	3-phase full wave rectifying, T <sub>c</sub> = 125°C (Note. 1)	75	A
I <sub>FSM</sub>	Surge forward current	The sine half wave 1 cycle peak value, f = 60Hz, non-repetitive	750	
i <sup>2</sup> t	Current square time	Value for one cycle of surge current	2340	A <sup>2</sup> s

#### MODULE

Symbol	Parameter	Conditions	Rating	Unit
T <sub>j</sub>	Junction temperature		-40 ~ +150	°C
T <sub>stg</sub>	Storage temperature		-40 ~ +125	
V <sub>isol</sub>	Isolation voltage	Terminals to base plate, f = 60Hz, AC 1 min, RMS	2500	J
—	Base plate flatness	On the centerline X, Y (Note. 8)	±0 ~ +100	μm
—	Mounting torque	Mounting M5 screw	2.5 ~ 3.5	N·m
—	Weight	(Typical)	270	g

Note. 8: The base plate flatness measurement points are in the following figure.

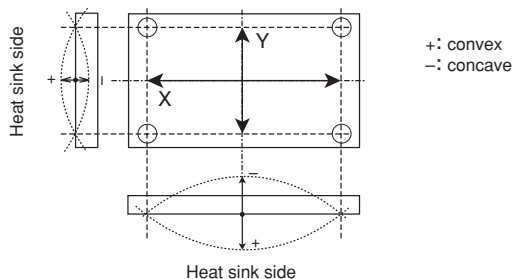

**CM75MX-12A**

**HIGH POWER SWITCHING USE**

**ELECTRICAL CHARACTERISTICS (T<sub>j</sub> = 25°C, unless otherwise specified)**

**INVERTER PART**

Symbol	Parameter	Conditions	Limits			Unit	
			Min.	Typ.	Max.		
ICES	Collector cut-off current	VCE = VCES, G-E Short	—	—	1	mA	
VGE(th)	Gate-emitter threshold voltage	IC = 7.5mA, VCE = 10V	5	6	7	V	
IGES	Gate-emitter leakage current	VGE = VGES, C-E Short	—	—	0.5	μA	
VCEsat	Collector-emitter saturation voltage	IC = 75A, VGE = 15V (Note. 6)	T <sub>j</sub> = 25°C	—	1.7	2.1	V
			T <sub>j</sub> = 125°C	—	1.9	—	
		IC = 75A, VGE = 15V	Chip	—	1.6	—	
Cies	Input capacitance	VCE = 10V, G-E Short (Note. 6)	—	—	9.3	nF	
Coes	Output capacitance		—	—	1.0		
Cres	Reverse transfer capacitance		—	—	0.3		
QG	Gate charge	VCC = 300V, IC = 75A, VGE = 15V	—	200	—	nC	
td(on)	Turn-on delay time	VCC = 300V, IC = 75A, VGE = ±15V, RG = 8.2Ω, Inductive load	—	—	100	ns	
tr	Rise time		—	—	100		
td(off)	Turn-off delay time		—	—	300		
tf	Fall time		—	—	600		
trr (Note.3)	Reverse recovery time		—	—	200		
Qrr (Note.3)	Reverse recovery charge	(IE = 75A)	—	1.8	—	μC	
VEC(Note.3)	Emitter-collector voltage	IE = 75A, G-E Short (Note. 6)	T <sub>j</sub> = 25°C	—	2.0	2.8	V
			T <sub>j</sub> = 125°C	—	1.95	—	
			Chip	—	1.9	—	
Rth(j-c)Q	Thermal resistance (Junction to case) (Note. 1)	per IGBT	—	—	0.44	K/W	
Rth(j-c)D		per free wheeling diode	—	—	0.85		
rg	Internal gate resistance	Tc = 25°C, per switch	—	0	—	Ω	
RG	External gate resistance		8.0	—	83		

**BRAKE PART**

Symbol	Parameter	Conditions	Limits			Unit	
			Min.	Typ.	Max.		
ICES	Collector cut-off current	VCE = VCES, G-E Short	—	—	1	mA	
VGE(th)	Gate-emitter threshold voltage	IC = 5mA, VCE = 10V	5	6	7	V	
IGES	Gate-emitter leakage current	VGE = VGES, C-E Short	—	—	0.5	μA	
VCEsat	Collector-emitter saturation voltage	IC = 50A, VGE = 15V (Note. 6)	T <sub>j</sub> = 25°C	—	1.7	2.1	V
			T <sub>j</sub> = 125°C	—	1.9	—	
		IC = 50A, VGE = 15V	Chip	—	1.6	—	
Cies	Input capacitance	VCE = 10V, G-E Short (Note. 6)	—	—	9.3	nF	
Coes	Output capacitance		—	—	1.0		
Cres	Reverse transfer capacitance		—	—	0.3		
QG	Gate charge	VCC = 300V, IC = 50A, VGE = 15V	—	200	—	nC	
IRRM(Note.3)	Repetitive peak reverse current	VR = VRRM	—	—	1	mA	
VF(Note.3)	Forward voltage	IF = 50A (Note. 6)	T <sub>j</sub> = 25°C	—	2.0	2.8	V
			T <sub>j</sub> = 125°C	—	1.95	—	
			Chip	—	1.9	—	
Rth(j-c)Q	Thermal resistance (Junction to case) (Note. 1)	per IGBT	—	—	0.44	K/W	
Rth(j-c)D		per Clamp diode	—	—	0.85		
rg	Internal gate resistance	Tc = 25°C	—	0	—	Ω	
RG	External gate resistance		13	—	125		

**CONVERTER PART**

Symbol	Parameter	Conditions	Limits			Unit
			Min.	Typ.	Max.	
IRRM	Repetitive peak reverse current	VR = VRRM, T <sub>j</sub> = 150°C	—	—	20	mA
VF	Forward voltage	IF = 75A	—	1.2	1.6	V
Rth(j-c)	Thermal resistance (Junction to case) (Note. 1)	per Diode	—	—	0.24	K/W

# CM75MX-12A

HIGH POWER SWITCHING USE

## NTC THERMISTOR PART

Symbol	Parameter	Conditions	Limits			Unit
			Min.	Typ.	Max.	
R25	Zero power resistance	Tc = 25°C	4.85	5.00	5.15	kΩ
ΔR/R	Deviation of resistance	Tc = 100°C, R100 = 493Ω	-7.3	—	+7.8	%
B(25/50)	B constant	Approximate by equation (Note. 7)	—	3375	—	K
P25	Power dissipation	Tc = 25°C	—	—	10	mW

## MODULE

Symbol	Parameter	Conditions	Limits			Unit
			Min.	Typ.	Max.	
Rth(c-s)	Contact thermal resistance (Case to heat sink) (Note. 1)	Thermal grease applied per 1 module (Note. 2)	—	0.015	—	K/W

Note. 1: Case temperature (Tc), heat sink temperature (Ts) measured point is just under the chips. (Refer to the figure of the chip location.)

2: Typical value is measured by using thermally conductive grease of λ = 0.9W/(m·K).

3: IE, IERM, VEC, tr, Qrr and Err represent ratings and characteristics of the anti-parallel, emitter-collector free wheeling diode (FWDi).

IF, IFRM, VF, VRRM and IRRM represent ratings and characteristics of the Clamp diode of Brake part.

4: Pulse width and repetition rate should be such that the device junction temperature (Tj) dose not exceed Tjmax rating.

5: Junction temperature (Tj) should not increase beyond 150°C.

6: Pulse width and repetition rate should be such as to cause negligible temperature rise.

(Refer to the figure of the test circuit for VCEsat and VEC)

$$7: B(25/50) = \ln\left(\frac{R_{25}}{R_{50}}\right) \left( \frac{1}{T_{25}} - \frac{1}{T_{50}} \right)$$

R25: resistance at absolute temperature T25 [K]; T25 = 25 [°C]+273.15 = 298.15 [K]

R50: resistance at absolute temperature T50 [K]; T50 = 50 [°C]+273.15 = 323.15 [K]

## Chip Location (Top view)

Dimensions in mm (tolerance: ±1mm)

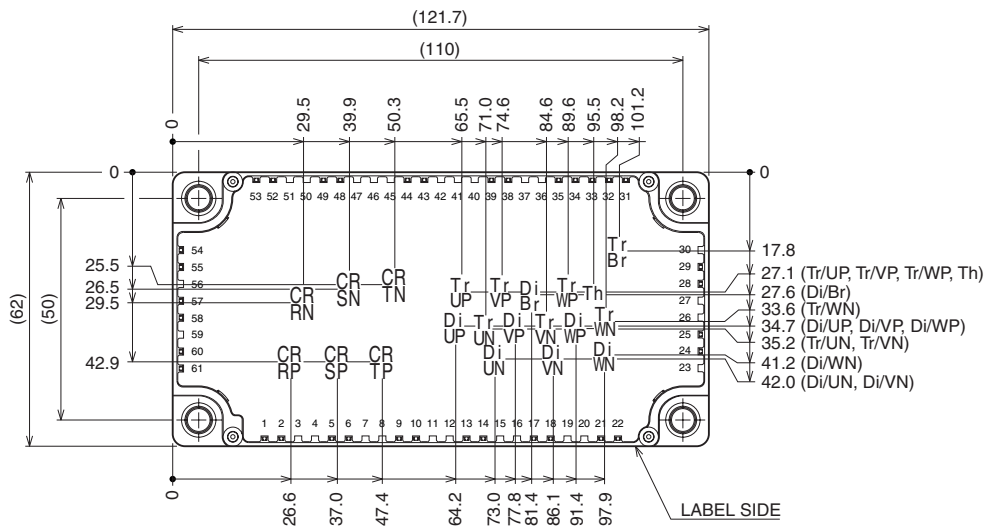

Each mark points the center position of each chip. Tr\*\*: IGBT, Di\*\*: FWDi (DiBr: Clamp diode), CR\*\*: Converter diode, Th: NTC thermistor

# CM75MX-12A

## HIGH POWER SWITCHING USE

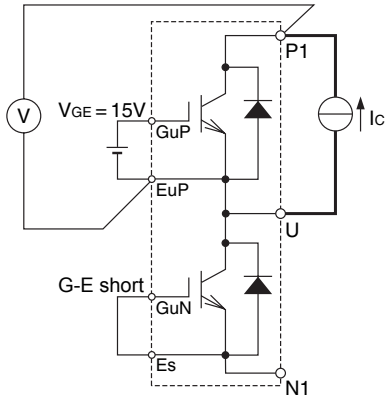

P side Inverter part Tr  
(example of U arm)  
G-E short

(GvP-EvP, GwP-EwP, GvN-Es, GwN-Es, GB-Es) (GvP-EvP, GwP-EwP, GvN-Es, GwN-Es, GB-Es)

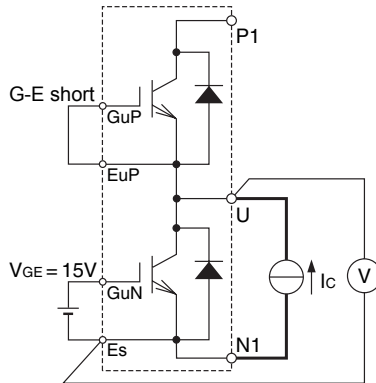

N side Inverter part Tr  
(example of U arm)  
G-E short

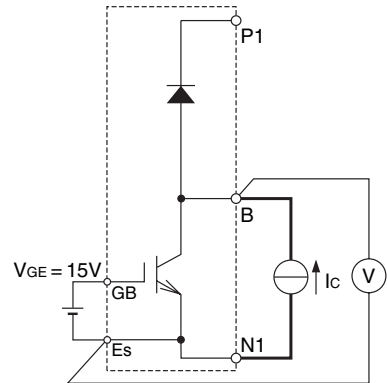

Br Tr

G-E short  
(GuP-EuP, GvP-EvP, GwP-EwP, GuN-Es, GvN-Es, GwN-Es)

### VCEsat test circuit

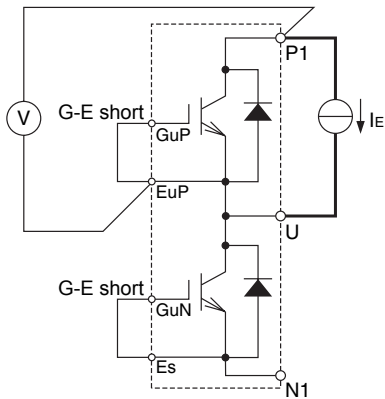

P side Inverter part Di  
(example of U arm)  
G-E short

(GvP-EvP, GwP-EwP, GvN-Es, GwN-Es, GB-Es) (GvP-EvP, GwP-EwP, GvN-Es, GwN-Es, GB-Es)

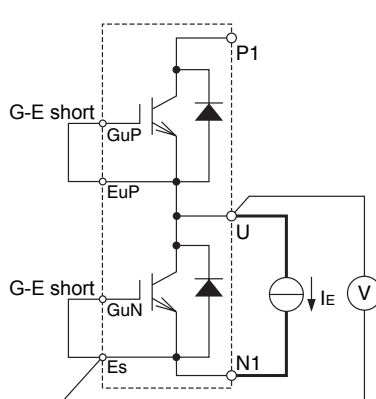

N side Inverter part Di  
(example of U arm)  
G-E short

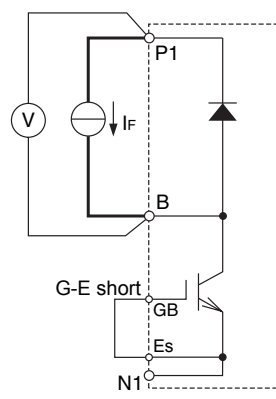

Br Di

G-E short  
(GuP-EuP, GvP-EvP, GwP-EwP, GuN-Es, GvN-Es, GwN-Es)

### Vec/Vf test circuit

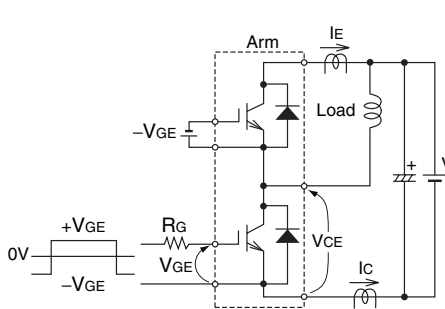

Switching time test circuit and waveforms

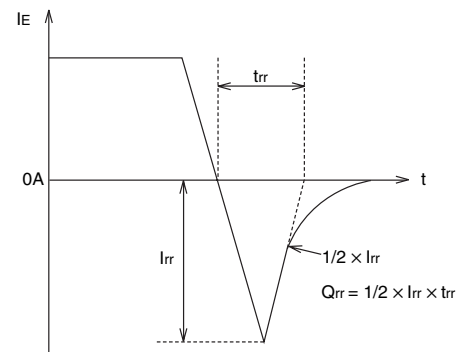
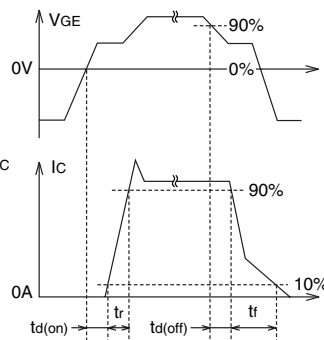

trr, Qrr test waveform

# CM75MX-12A

HIGH POWER SWITCHING USE

## PERFORMANCE CURVES

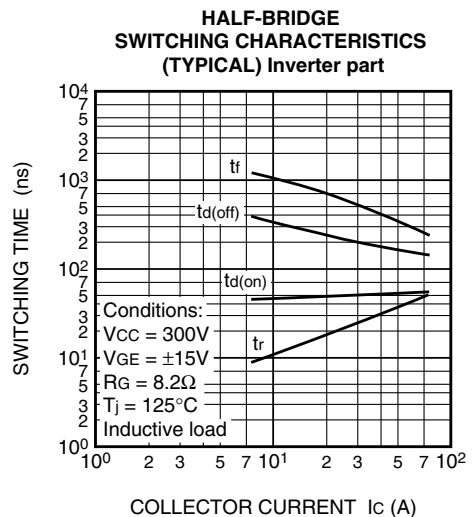
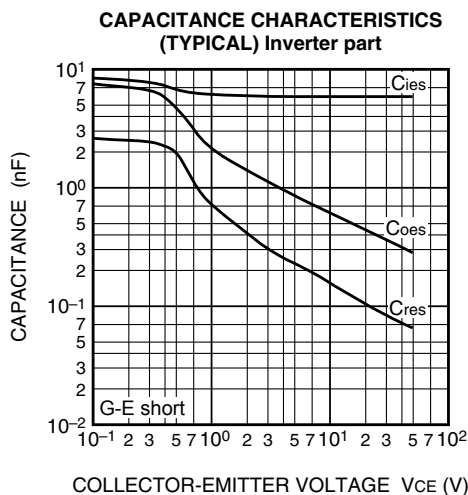
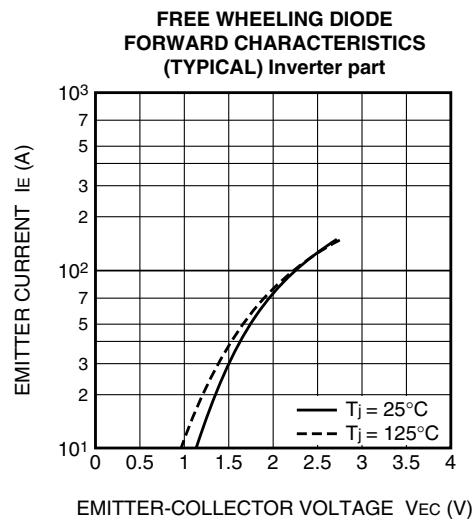
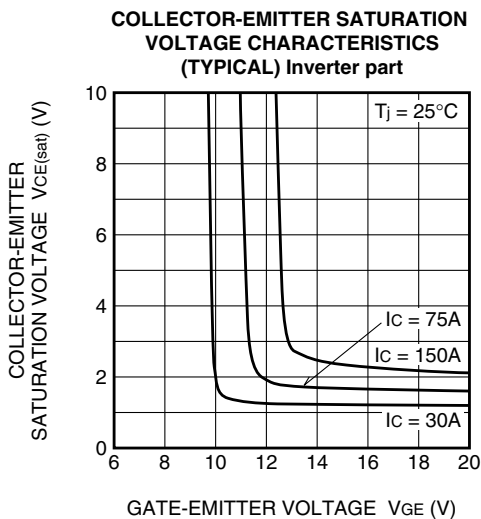
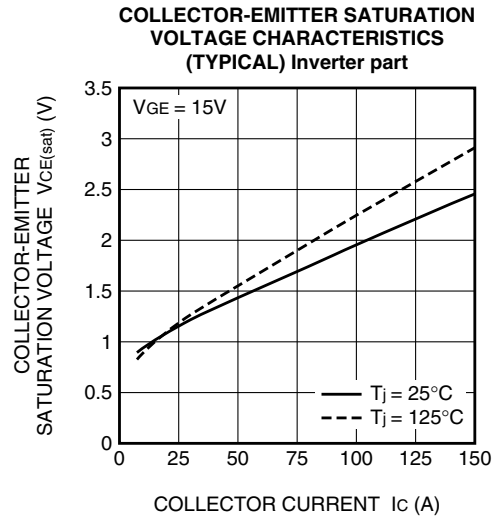
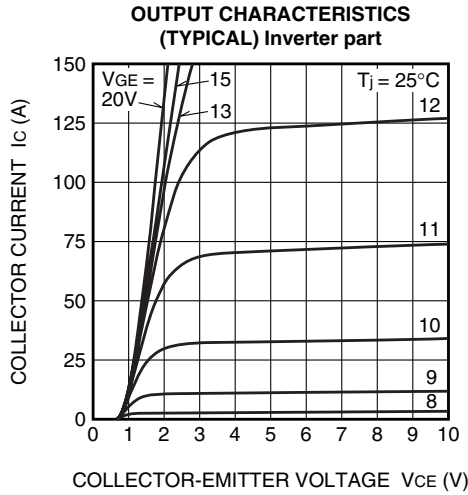

HALF-BRIDGE SWITCHING CHARACTERISTICS (TYPICAL) Inverter part

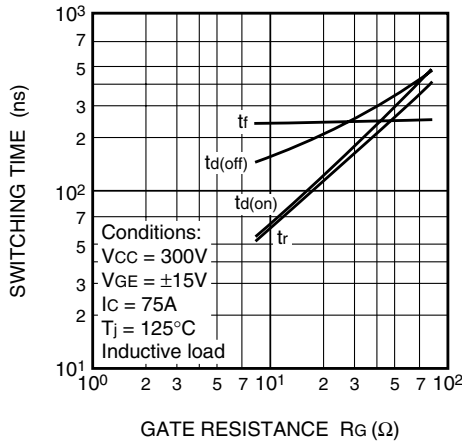

HALF-BRIDGE SWITCHING CHARACTERISTICS (TYPICAL) Inverter part

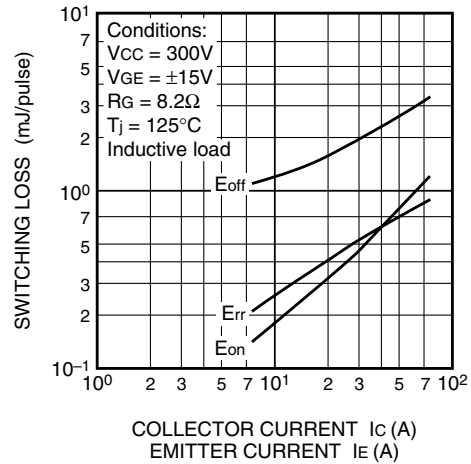

HALF-BRIDGE SWITCHING CHARACTERISTICS (TYPICAL) Inverter part

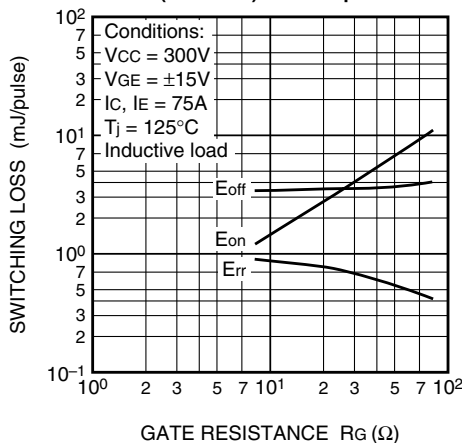

REVERSE RECOVERY CHARACTERISTICS OF FREE WHEELING DIODE (TYPICAL) Inverter part

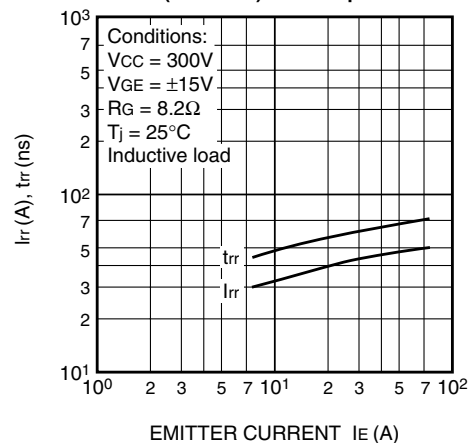

GATE CHARGE CHARACTERISTICS (TYPICAL) Inverter part

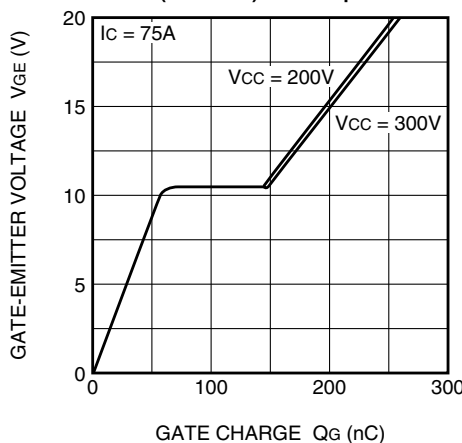

TRANSIENT THERMAL IMPEDANCE CHARACTERISTICS

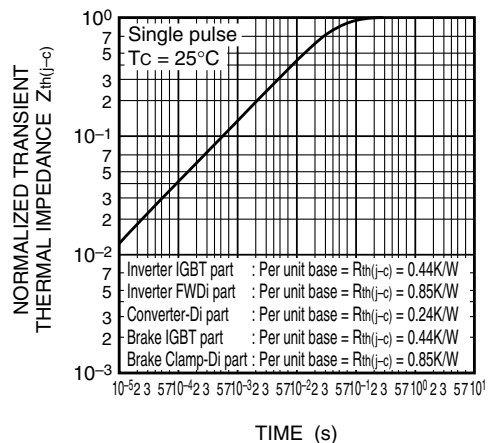

CM75MX-12A

HIGH POWER SWITCHING USE

**RECTIFIER DIODE  
FORWARD CHARACTERISTICS  
(TYPICAL) Converter part**

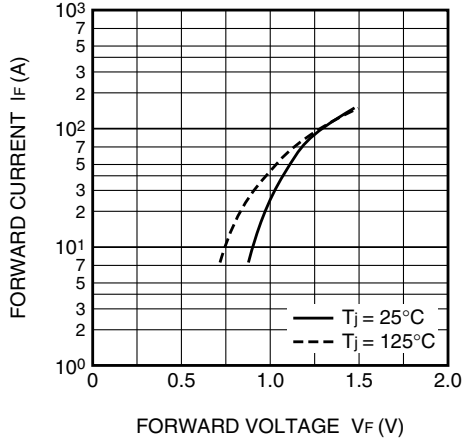

**COLLECTOR-EMITTER SATURATION  
VOLTAGE CHARACTERISTICS  
(TYPICAL) Brake part**

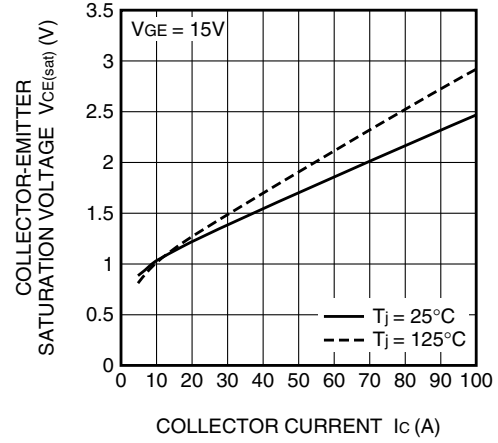

**CLAMP DIODE  
FORWARD CHARACTERISTICS  
(TYPICAL) Brake part**

